

## FEATURES

- **±2% Overvoltage Threshold Accuracy**
- **Low Profile (1mm) ThinSOT™ Package**
- Gate Drive for SCR Crowbar or External N-Channel Disconnect MOSFET
- Monitors Two Output Voltages
- Senses Output Voltages from 0.8V to 24V
- Wide Supply Range: 2.7V to 27V
- Multifunction TIMER/RESET Pin

## APPLICATIONS

- Telecommunication Systems
- Computer Systems
- Industrial Control Systems
- Notebook Computers

## DESCRIPTION

The LTC<sup>®</sup>1696 is a standalone power supply overvoltage monitor and protection device designed to protect a power supply load in the event of an overvoltage fault. It monitors two adjustable output voltages. If an overvoltage condition is detected, the output drives either an external SCR crowbar or turns off external back-to-back N-channel MOSFETs, thereby, disconnecting the input voltage from the power supply.

Pin 6 offers three functions. By connecting a capacitor to this pin, the internal glitch filter time delay can be programmed. Without the capacitor, the default time delay is determined by an internal capacitor. This pin also serves as a reset input to clear the internal latch after an overvoltage fault condition. By pulling it high, the OUT pin is activated if the FB1 and FB2 voltages remain below the trip threshold.

The LTC1696 is available in the low profile (1mm) ThinSOT package.

LT, LTC and LT are registered trademarks of Linear Technology Corporation. ThinSOT is a trademark of Linear Technology Corporation.

## TYPICAL APPLICATION

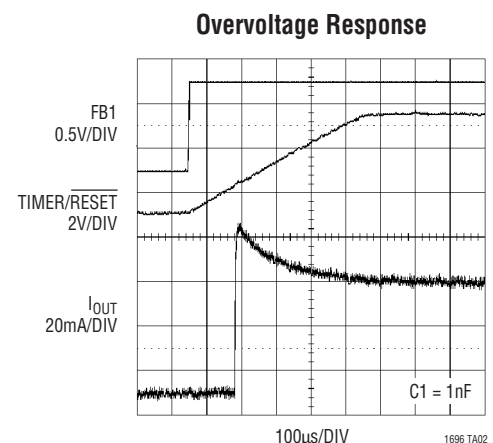
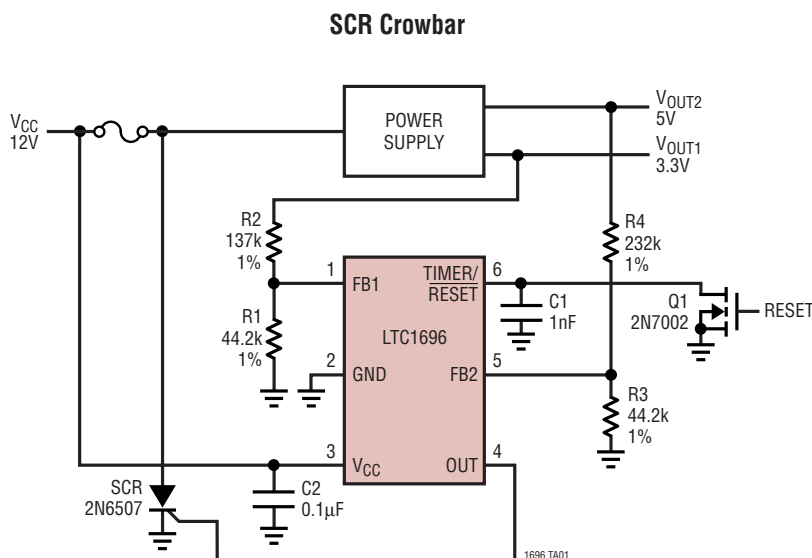

## ABSOLUTE MAXIMUM RATINGS

(Note 1)

Supply Voltage ( $V_{CC}$ ) .....	28V
Input Voltage	
FB1, FB2 .....	-0.3V to 17V
TIMER/RESET .....	-0.3V to 17V
Operating Temperature Range (Note 2) ..	-40°C to 85°C
Storage Temperature Range .....	-65°C to 150°C
Lead Temperature (Soldering, 10 sec).....	300°C

## PACKAGE/ORDER INFORMATION

	ORDER PART NUMBER
	LTC1696ES6
	S6 PART MARKING
	LTLT

Consult LTC Marketing for parts specified with wider operating temperature ranges.

## ELECTRICAL CHARACTERISTICS

The ● denotes the specifications which apply over the full operating temperature range, otherwise specifications are at  $T_A = 25^\circ\text{C}$ .  $2.7\text{V} \leq V_{CC} \leq 27\text{V}$  (Notes 3, 4) unless otherwise noted.

SYMBOL	PARAMETER	CONDITIONS	MIN	TYP	MAX	UNITS
$V_{CC}$	Supply Voltage Range	Operating Range	● 2.7		27	V
$I_{VCC}$	Standby Supply Current	FB1, FB2 < $V_{FB}$	●	170	540	$\mu\text{A}$
	Active Supply Current	FB1, FB2 > $V_{FB}$ , $C_{OUT} = 1000\text{pF}$	●	1.1	3.5	$\text{mA}$
$V_{FB}$	FB1, FB2 Feedback Threshold	Voltage Going Positive $T_A \geq 0^\circ\text{C}$	● 0.862	0.880	0.898	V
		$T_A < 0^\circ\text{C}$	● 0.853	0.880	0.907	V
$I_{FB}$	FB1, FB2 Input Current		● -1	-0.05		$\mu\text{A}$
$V_{FBHST}$	FB1, FB2 Feedback Hysteresis	High-to-Low Transition		12		$\text{mV}$
$V_{LKO}$	$V_{CC}$ Undervoltage Lockout Low-to-High Transition High-to-Low Transition		● 1.75	2.05	2.35	V
			● 1.64	1.94	2.24	V
$V_{LKH}$	$V_{CC}$ Undervoltage Lockout Hysteresis	FB1, FB2 > $V_{FB}$		110		$\text{mV}$
$V_{RST}$	TIMER/RESET Reset Low Threshold	FB1, FB2 > $V_{FB}$	● 0.78	0.865	0.95	V
$V_{TIM}$	TIMER/RESET Timer High Threshold	FB1, FB2 > $V_{FB}$	● 1.11	1.185	1.26	V
$V_{TRIG}$	TIMER/RESET External Trigger High Threshold	FB1, FB2 < $V_{FB}$	● 1.35	1.50	1.65	V
$I_{TRIG}$	TIMER/RESET External Trigger High Current	FB1, FB2 < $V_{FB}$ , TIMER/RESET = $V_{TRIG}$	●	260	650	$\mu\text{A}$
$I_{TIM}$	TIMER/RESET Timer Current	FB1 = ( $V_{FB} + 30\text{mV}$ ), FB2 < $V_{FB}$	● 4	10	22	$\mu\text{A}$
		FB1 = ( $V_{FB} + 200\text{mV}$ ), FB2 < $V_{FB}$	● 5	12	26	$\mu\text{A}$
		FB2 = ( $V_{FB} + 30\text{mV}$ ), FB1 < $V_{FB}$	● 4	10	22	$\mu\text{A}$
		FB2 = ( $V_{FB} + 200\text{mV}$ ), FB1 < $V_{FB}$	● 5	12	26	$\mu\text{A}$
		FB1, FB2 = ( $V_{FB} + 200\text{mV}$ )	● 8	18	40	$\mu\text{A}$
$V_{OUTH}$	OUT High Voltage	$12\text{V} \leq V_{CC} \leq 27\text{V}$ , FB1, FB2 > $V_{FB}$ , $C_{OUT} = 1000\text{pF}$	● 4.8	6.3	8.0	V
		$V_{CC} = 3.3\text{V}$ , FB1, FB2 > $V_{FB}$ , $C_{OUT} = 1000\text{pF}$	● 2.7	3.2	3.3	V
$V_{OUTL}$	OUT Low Voltage	FB1, FB2 < $V_{FB}$ , $I_{SINK} = 1\text{mA}$ , $V_{CC} = 3.3\text{V}$	●		0.45	V
$t_{OVPD1}$	OUT Propagation Delay for FB1	FB1 > $V_{FB}$ , FB2 < $V_{FB}$ , TIMER/RESET = Open, $C_{OUT} = 1000\text{pF}$	●	7	28	$\mu\text{s}$
$t_{OVPD2}$	OUT Propagation Delay for FB2	FB2 > $V_{FB}$ , FB1 < $V_{FB}$ , TIMER/RESET = Open, $C_{OUT} = 1000\text{pF}$	●	7	28	$\mu\text{s}$

## ELECTRICAL CHARACTERISTICS

The ● denotes the specifications which apply over the full operating temperature range, otherwise specifications are at  $T_A = 25^\circ\text{C}$ .  $2.7\text{V} \leq V_{CC} \leq 27\text{V}$  (Notes 3, 4) unless otherwise noted.

SYMBOL	PARAMETER	CONDITIONS	MIN	TYP	MAX	UNITS	
$t_{OVPD1,2}$	OUT Propagation Delay for FB1, FB2	FB1, FB2 > $V_{FB}$ , TIMER/RESET = Open $C_{OUT} = 1000\text{pF}$	●	6	24	$\mu\text{s}$	
$t_r$	OUT Rise Time	FB1, FB2 > $V_{FB}$ , $C_{OUT} = 1000\text{pF}$	●	0.4	3	$\mu\text{s}$	
$I_{OUTSC}$	OUT Short-Circuit Current	$12\text{V} \leq V_{CC} \leq 27\text{V}$ , FB1, FB2 > $V_{FB}$ , $V_{OUT}$ Shorted to GND	●	35	80	160	mA
		$V_{CC} = 2.7\text{V}$ , FB1, FB2 > $V_{FB}$ , $V_{OUT}$ Shorted to GND	●	2	9	18	mA

**Note 1:** Absolute Maximum Ratings are those values beyond which the life of the device may be impaired.

**Note 2:** The LTC1696E is guaranteed to meet performance specifications from  $0^\circ\text{C}$  to  $70^\circ\text{C}$ . Specifications over the  $-40^\circ\text{C}$  to  $85^\circ\text{C}$  operating temperature range are assured by design, characterization and correlation with statistical process controls.

**Note 3:** All currents into device pins are positive; all currents out of device pins are negative. All voltages are referenced to device ground unless otherwise specified.

**Note 4:** All typical numbers are given for  $V_{CC} = 12\text{V}$  and  $T_A = 25^\circ\text{C}$ .

# TYPICAL PERFORMANCE CHARACTERISTICS

**Standby Supply Current vs Supply Voltage**

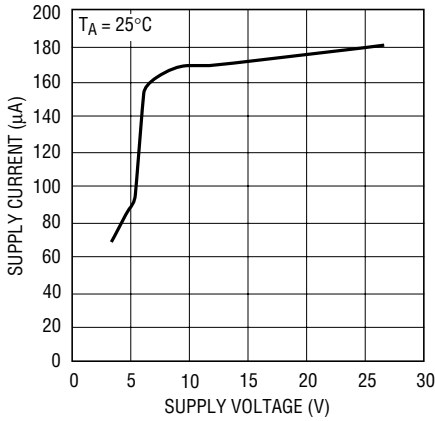

1696 G01

**Standby Supply Current vs Temperature**

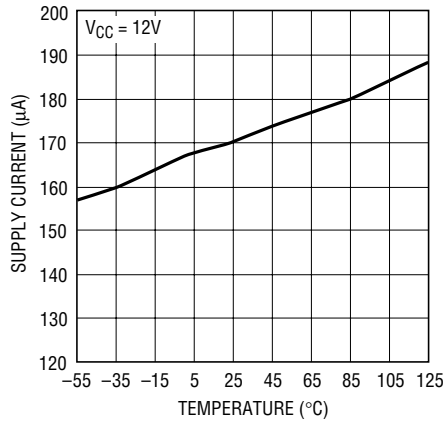

1696 G02

**Active Supply Current vs Supply Voltage**

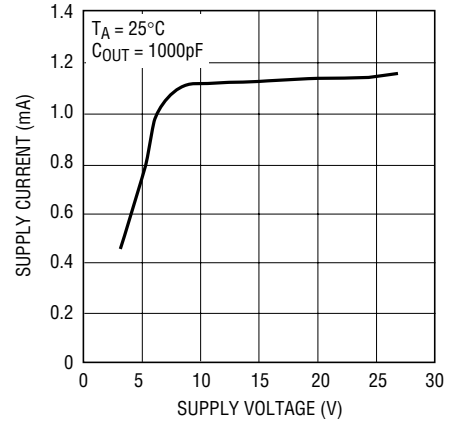

1696 G03

**Active Supply Current vs Temperature**

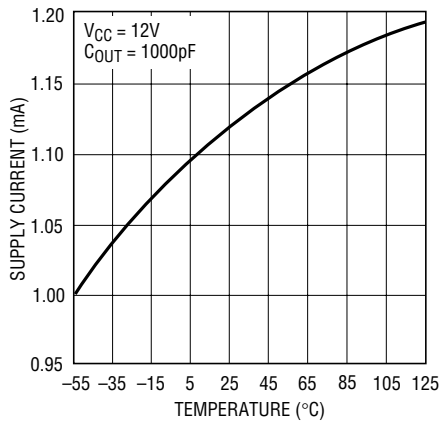

1696 G04

**FB1, FB2 Feedback Threshold Voltage vs Supply Voltage**

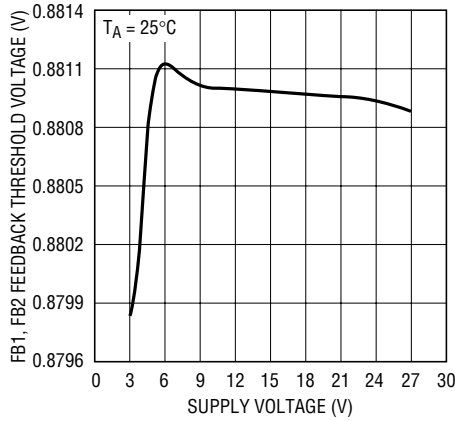

1696 G05

**FB1, FB2 Feedback Threshold Voltage vs Temperature**

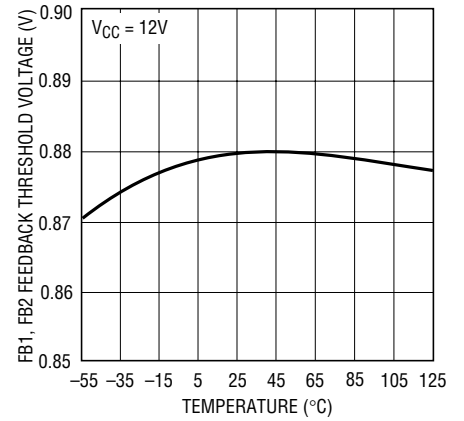

1696 G06

**TIMER Threshold Voltage vs Supply Voltage**

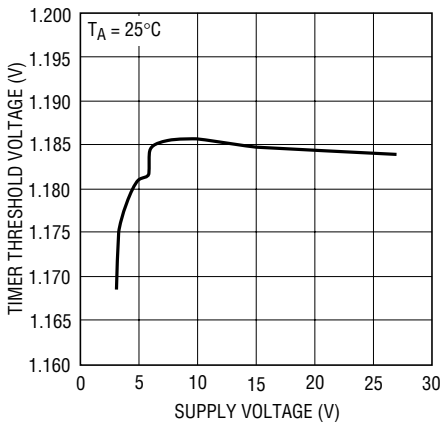

1696 G07

**TIMER Threshold Voltage vs Temperature**

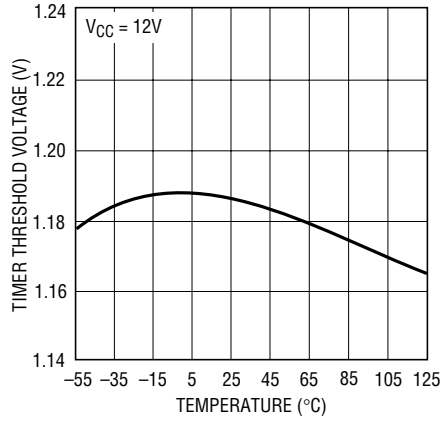

1696 G08

**TIMER Current vs Supply Voltage**

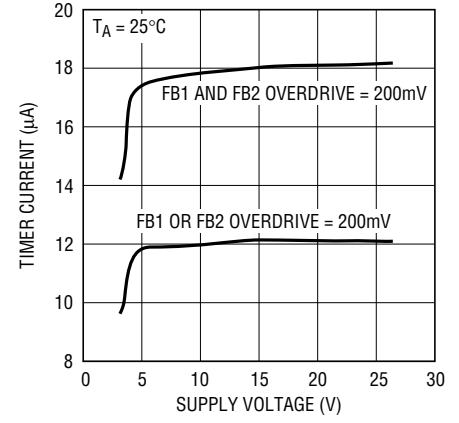

1696 G09

# TYPICAL PERFORMANCE CHARACTERISTICS

**TIMER Current vs Temperature**

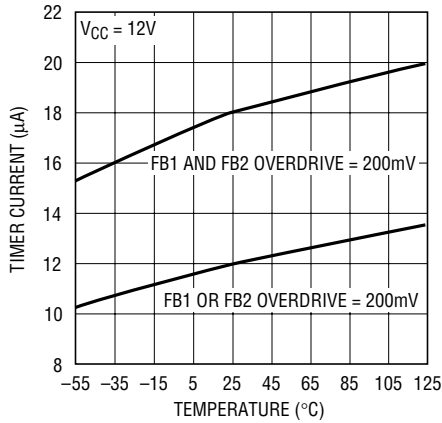

1696 G10

**TIMER Current vs Feedback Overdrive**

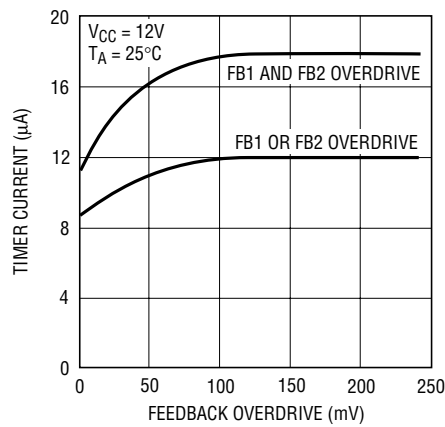

1696 G11

**TIMER Current vs Feedback Overdrive**

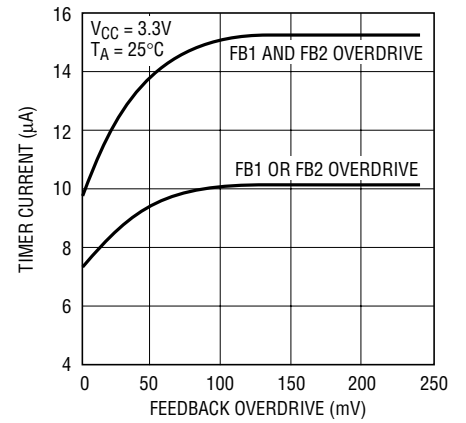

1696 G12

**Glitch Filter Timer vs Feedback Overdrive**

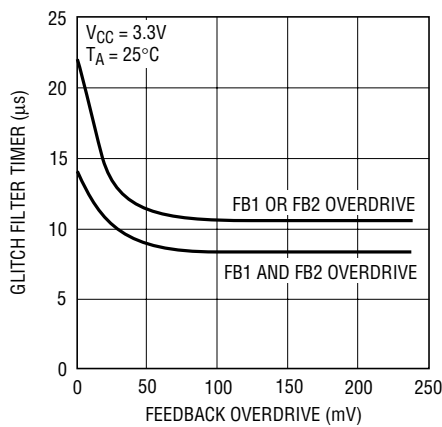

1696 G13

**Glitch Filter Timer vs Feedback Overdrive**

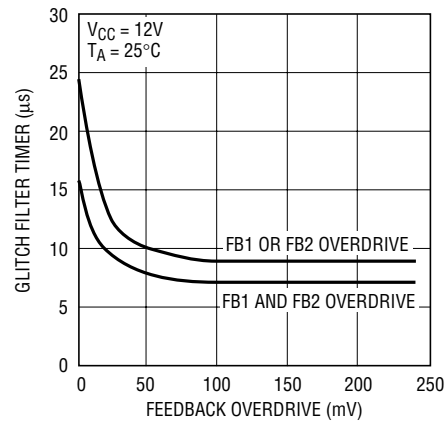

1696 G14

**External Trigger Threshold Voltage vs Supply Voltage**

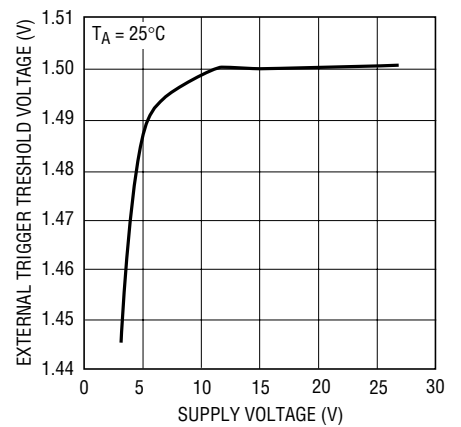

1696 G15

**External Trigger Threshold Voltage vs Temperature**

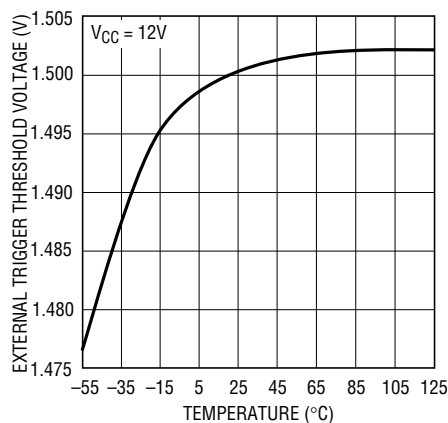

1696 G16

**RESET Threshold Voltage vs Supply Voltage**

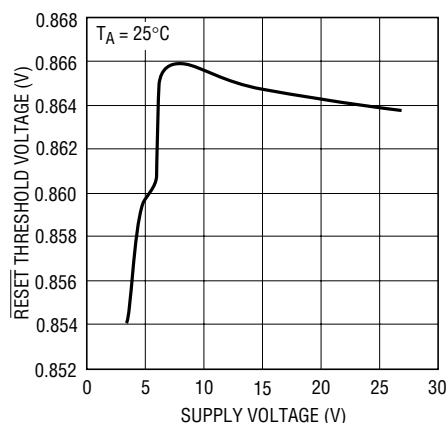

1696 G17

**RESET Threshold Voltage vs Temperature**

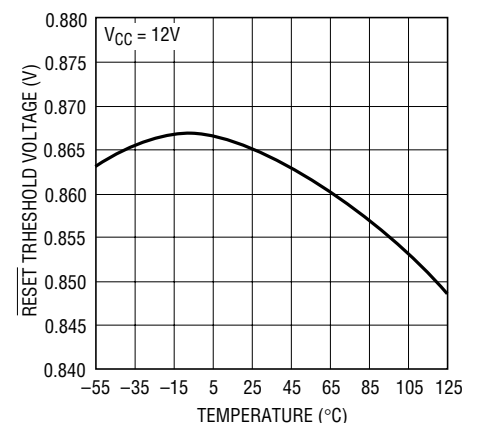

1696 G18

# TYPICAL PERFORMANCE CHARACTERISTICS

**OUT Pin Active Output Voltage vs Supply Voltage**

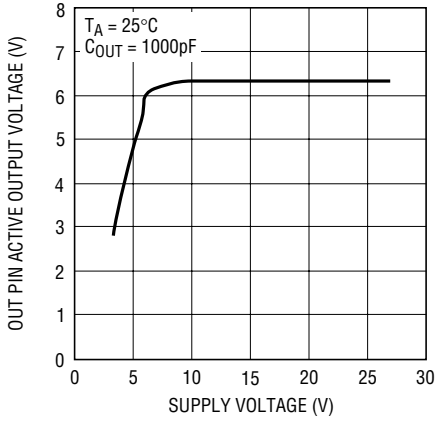

1696 G19

**OUT Pin Active Output Voltage vs Temperature**

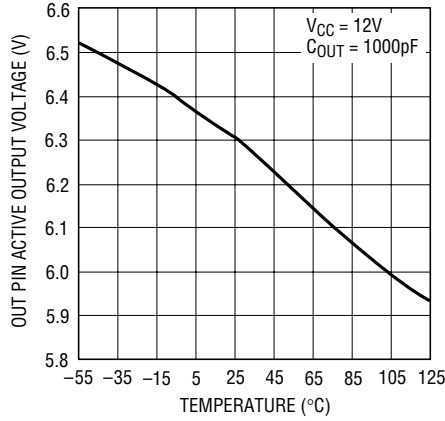

1696 G20

**OUT Pin Short-Circuit Current vs Supply Voltage**

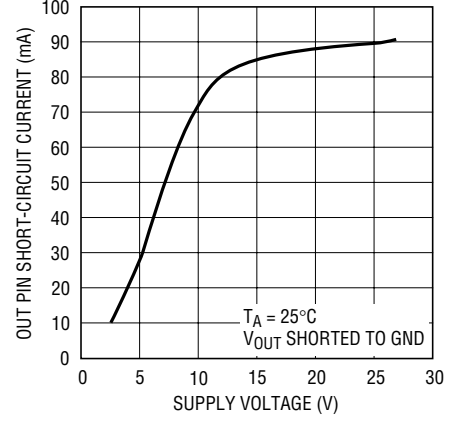

1696 G21

**OUT Pin Short-Circuit Current vs Temperature**

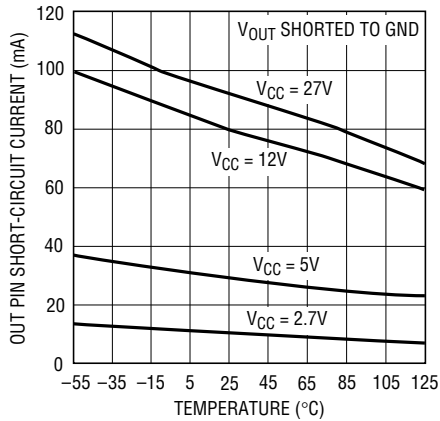

1696 G22

**OUT Pin Active Output Current vs Output Voltage**

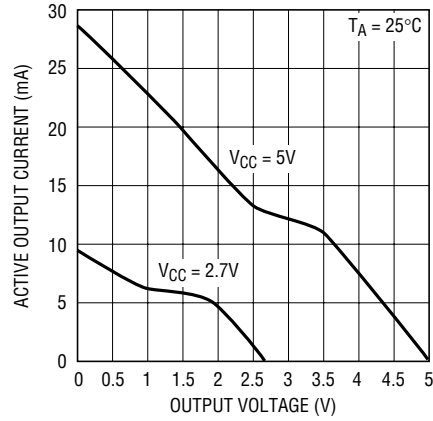

1696 G23

**OUT Pin Active Output Current vs Output Voltage**

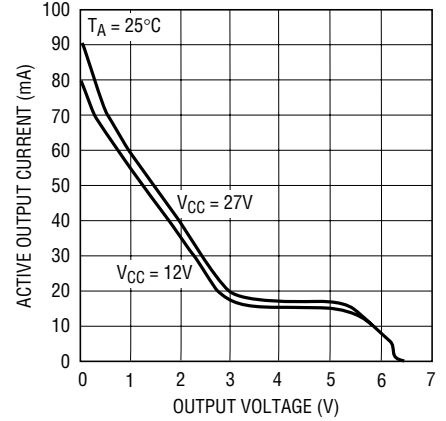

1696 G24

## PIN FUNCTIONS

**FB1 (Pin 1):** First Feedback Input. FB1 monitors and senses the first supply output voltage through an external resistor divider. This voltage is then compared with an internal reference voltage of 0.88V, which sets the threshold for an overvoltage fault detection. If the sense voltage exceeds the threshold level, the output response time at the OUT pin is dependent on the feedback overdrive above the threshold level. The higher the feedback overdrive, the faster will be the response time.

**GND (Pin 2):** Power Ground. Return path for all device currents.

**V<sub>CC</sub> (Pin 3):** Power Supply. The pin is connected separately from the power supply output that the chip is monitoring. Its input range is from 2.7V to 27V. The quiescent current is typically 100 $\mu$ A in standby mode when the device is operating at 5V. The quiescent current increases to 170 $\mu$ A when operating at 12V.

**OUT (Pin 4):** Output Current Limit Driver. Capable of delivering continuous current, typically 80mA, at high supplies. The output current decreases with lower supply voltage. This pin directly drives the SCR crowbar at high supply voltage. It can also provide gate drive for an N-channel MOSFET or the base of an NPN transistor, which drives the gate of an external SCR at low supply voltage. It is normally in the inactive low state in the standby mode. In the event of an overvoltage fault condition, the OUT pin is latched into the active high state. The latched active high state is reset by pulling the TIMER/RESET pin low through an N-channel MOSFET switch or if the supply voltage at the V<sub>CC</sub> pin goes below the undervoltage lockout threshold voltage of 1.94V.

**FB2 (Pin 5):** Second Feedback Input. FB2 monitors and senses the second supply output voltage through an external resistor divider. This voltage is then compared with an internal reference voltage of 0.88V, which sets the threshold for an overvoltage fault detection. If the sense voltage exceeds the threshold level, the output response time at the OUT pin is dependent on the feedback overdrive above the threshold level. The higher the feedback overdrive, the faster will be the response time.

**TIMER/RESET (Pin 6):** Glitch Filter Timer Capacitor, Reset and External Trigger Input. The external capacitor connected to this pin programs the internal glitch filter time delay. The internal current source used to charge the timer capacitor is typically 10 $\mu$ A with feedback overdrive of less than 20mV above the feedback trip threshold from one feedback input. The current source increases to 12 $\mu$ A when the feedback overdrive increases to more than 100mV. It further increases to 18 $\mu$ A if larger overdrive occurs from both feedback inputs. The default glitch filter time delay without an external timer capacitor is fixed by an internal capacitor of 5pF with the internal reference voltage of 1.185V. The delay reduces with increases in first and second feedback input overdrive. This pin also serves as a reset input to clear the internal latch during an overvoltage fault condition. If pulled low, it resets the active high state of the internal latch. The reset signal to this pin should be an open drain type. This pin can also be driven high externally to activate the OUT pin active high if the FB1 and FB2 voltages remain below the feedback trip threshold.

## BLOCK DIAGRAM

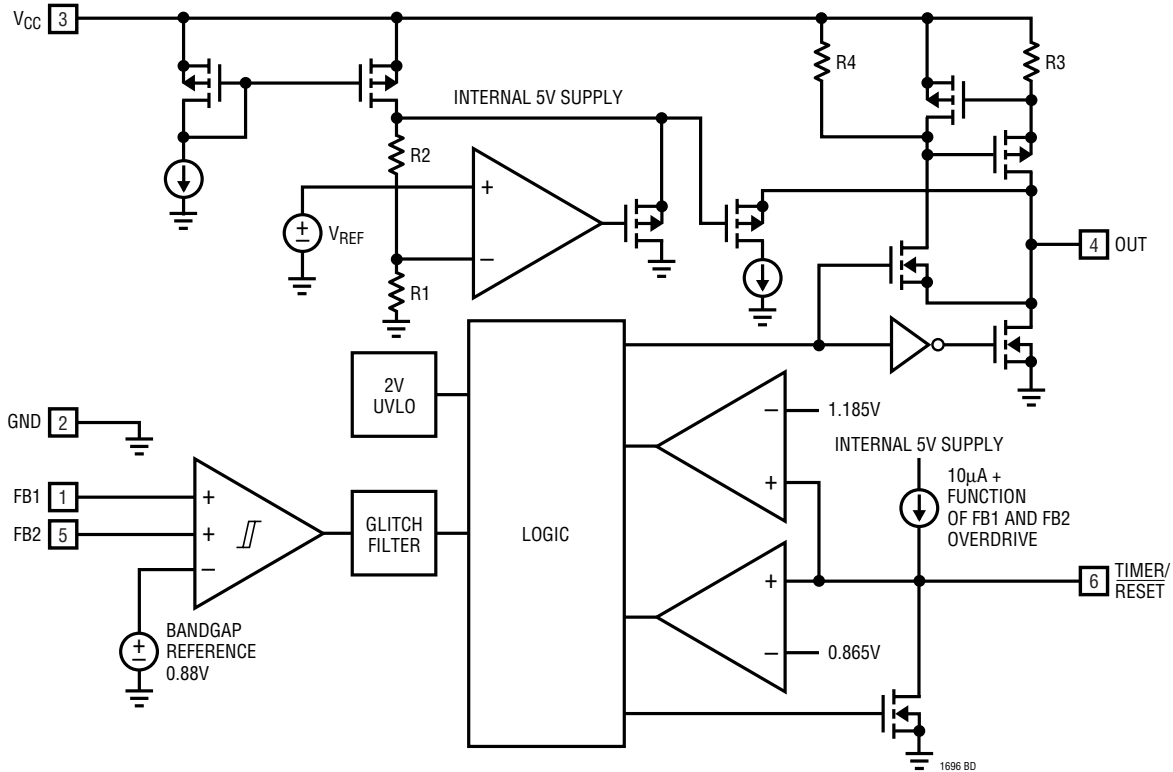

## APPLICATIONS INFORMATION

### Feedback Inputs

The LTC1696 has two feedback inputs that allow monitoring of two output voltages. The trip point of the internal comparator is set by an internal reference of 0.88V with  $\pm 2\%$  accuracy. The output voltage,  $V_S$ , is sensed through an external resistor divider network (Figure 1). The resistors R1 and R2 values are calculated with the typical trip point of 0.88V.

$$\frac{R1}{R1+R2} \cdot V_S = 0.88$$

$$R2 = \frac{(V_S - 0.88) \cdot R1}{0.88}$$

As an example, let's calculate values for R1 and R2 for a 3.3V supply in which an overvoltage indication is required

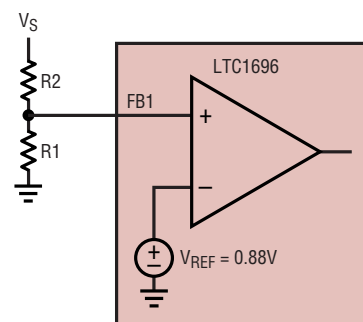

Figure 1

at +10% (3.63V). First, a value for R1 is chosen based on the allowable resistor divider string current. This is determined by power dissipation requirements and possible sensitivity to noise coupling into the resistor divider. In this exercise, assume the resistor divider current is 20 $\mu$ A. R1 is calculated from:



## APPLICATIONS INFORMATION

$$R1 = \frac{V_{FB}}{I_{DIVIDER}} = \frac{0.88V}{20\mu A} = 44k$$

The nearest 1% value for R1 is 44.2k. Now, calculating for R2 yields:

$$R2 = \frac{44.2k \cdot (3.63V - 0.88V)}{0.88V} = 138.1k$$

Choosing the nearest 1% value yields 137k.

The chosen values for R1 and R2 yield an overvoltage threshold of 3.608V (+9.3%). With worst-case tolerances applied, the minimum overvoltage threshold is 3.481V (+5.5%) and the maximum overvoltage threshold is 3.738V (+13.3%).

### Reset Function

In the event of an overvoltage condition, the OUT pin of the LTC1696 is latched into an active high state. The internal latch is reset by pulling the TIMER/RESET pin low through an external N-channel MOSFET switch or pulling  $V_{CC}$  voltage below the UVLO trip point of 1.94V.

### Glitch Filter Timer

The LTC1696 has a programmable glitch filter to prevent the output from entering its active high latched condition if transients occur on the FB1 or FB2 pins. The filter time delay is programmed externally by an external capacitor C1 connected to the TIMER/RESET pin.

$$\text{The time delay is given by: } t_D = \frac{C1 \cdot V_{INT}}{I_{CHG}}$$

where  $V_{INT}$  is the internal reference voltage of 1.185V and  $I_{CHG}$  is the internal current source charging the external capacitor C1. The current source  $I_{CHG}$  charging the external timer capacitor is 10 $\mu$ A for small feedback transients and increases to 12 $\mu$ A for large feedback transients (greater than 100mV) from one feedback input. The charging current increases to 18 $\mu$ A for large feedback transients from both feedback inputs.

### SCR Crowbar

The LTC1696 can deliver continuous output current typically 80mA at high supply voltage to trigger an external SCR crowbar in the event of an overvoltage condition as shown in the typical application on the front page of the data sheet. The output current decreases when the supply voltage reduces. It delivers 25mA at a supply voltage of 5V. At a low supply voltage of 3.3V, the output current reduces to 10mA and an external NPN emitter follower is needed to boost the current in order to drive the SCR crowbar as shown in Figure 2. The power dissipation due to the high output current at high supply voltage can potentially exceed the thermal limit of the package. This is avoided by resetting the device rapidly when the external SCR crowbar has been triggered, so that the device is not kept in the active high state for too long.

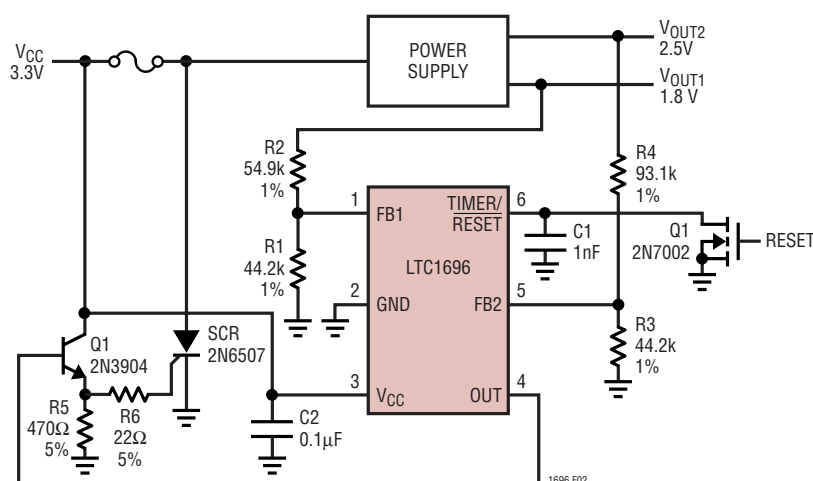

Figure 2. External SCR with NPN Emitter Follower with Low Voltage Supplies

## APPLICATIONS INFORMATION

### Back-to-Back N-Channel MOSFET

A power management circuit that uses the LTC1696 to control external back-to-back N-channel MOSFET at low supply voltage is shown in Figure 3. In standby mode, the drain of the external N-channel MOSFET, Q1, is pulled high

by the power management controller when the LTC1696 OUT pin is in the low state. The LTC1696 drives the gate of Q1 high during an overvoltage fault condition. This pulls the drain of Q1 low and turns off the back-to-back N-channel MOSFETs.

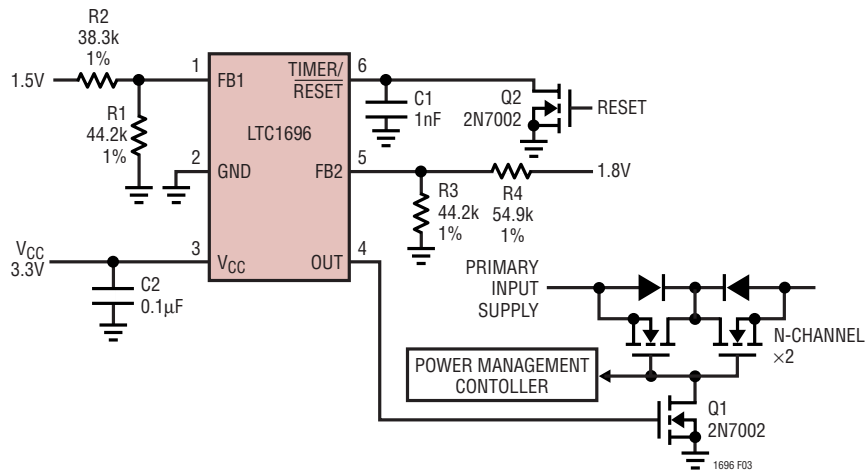
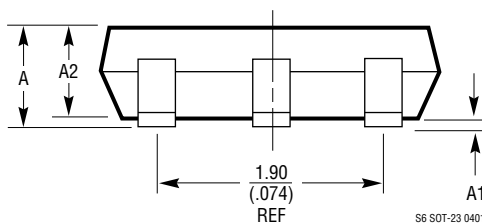
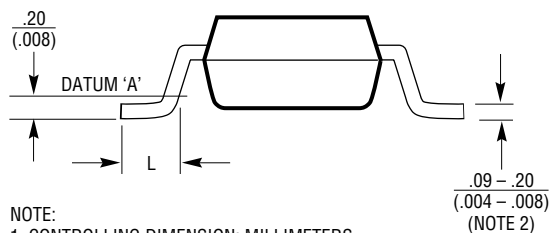
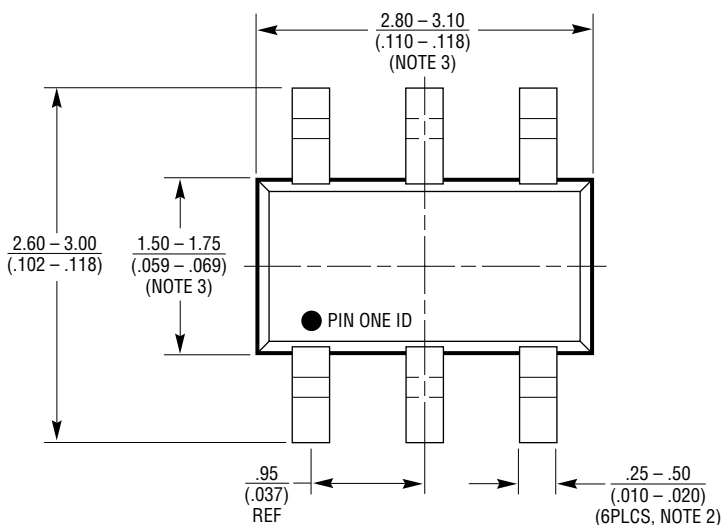

Figure 3. Back-to-Back N-Channel MOSFETs for Low Supply Application

# PACKAGE DESCRIPTION

**S6 Package**  
**6-Lead Plastic SOT-23**  
 (LTC DWG # 05-08-1634)  
 (LTC DWG # 05-08-1636)

	SOT-23 (Original)	SOT-23 (ThinSOT)
A	.90 - 1.45 (.035 - .057)	1.00 MAX (.039 MAX)
A1	.00 - 0.15 (.00 - .006)	.01 - .10 (.0004 - .004)
A2	.90 - 1.30 (.035 - .051)	.80 - .90 (.031 - .035)
L	.35 - .55 (.014 - .021)	.30 - .50 REF (.012 - .019 REF)



- NOTE:
1. CONTROLLING DIMENSION: MILLIMETERS
  2. DIMENSIONS ARE IN  $\frac{\text{MILLIMETERS}}{\text{INCHES}}$
  3. DRAWING NOT TO SCALE
  4. DIMENSIONS ARE INCLUSIVE OF PLATING
  5. DIMENSIONS ARE EXCLUSIVE OF MOLD FLASH AND METAL BURR
  6. MOLD FLASH SHALL NOT EXCEED .254mm
  7. PACKAGE EIAJ REFERENCE IS:  
 SC-74A (EIAJ) FOR ORIGINAL  
 JEDEC MO-193 FOR THIN

## APPLICATIONS INFORMATION

### External Triggering

The LTC1696 has a feature which allows the output to be latched into an active high state by pulling the TIMER/RESET pin high. Figure 4 shows a circuit that uses the external triggering function of the LTC1696.

FB1 and FB2 pins are below the trip threshold of the internal comparator. The output is then reset by pulling the TIMER/RESET pin low. Figure 4 shows a circuit that uses the external triggering function of the LTC1696.

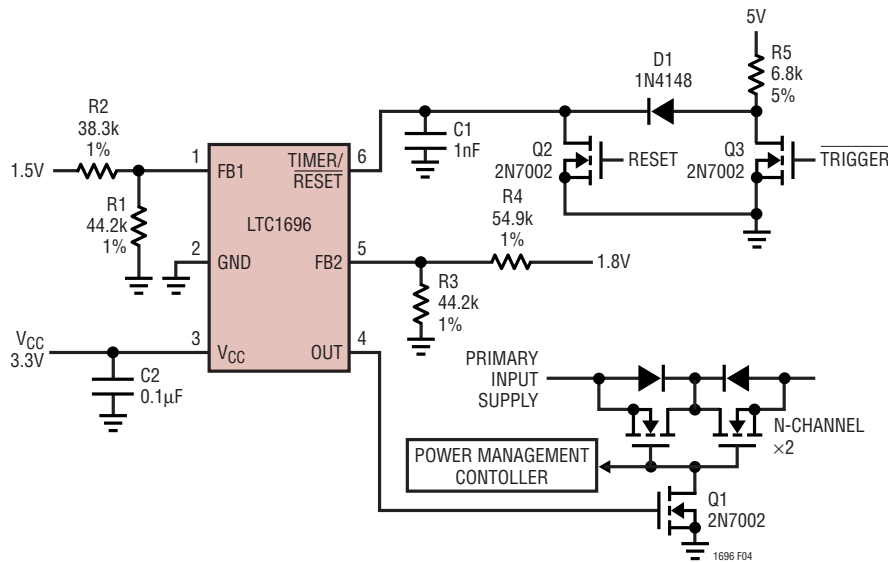

Figure 4. External Triggering

## RELATED PARTS

PART NUMBER	DESCRIPTION	COMMENTS
LTC1473	Dual PowerPath™ Switch Driver	For Systems with Multiple DC Sources, $V_{IN}$ Up to 30V, Inrush and Short-Circuit Protection
LTC1628	High Efficiency, 2-Phase Synchronous Step-Down Switching Regulator	Out-of-Phase Controllers, $3.5V \leq V_{IN} \leq 36V$ , $\pm 1\%$ Output Voltage Accuracy
LT1681	Dual Transistor Synchronous Forward Controller	Operation Up to 72V Maximum
LTC1698	Secondary Synchronous Rectifier Controller	Optocoupler Feedback with Pulse Transformer Synchronization
LTC1703	Dual 550k Synchronous 2-Phase Switching Regulator Controller with VID	Two Independent PWM Controllers, Wide Load Current Range, 1.5% Output Accuracy
LTC1735	Synchronous Step-Down Switching Regulator	Current Mode, $3.5V \leq V_{IN} \leq 36V$ , $0.5V \leq V_{OUT} \leq 5V$
LTC1922-1	Synchronous Phase Modulated Full-Bridge Controller	Output Power Levels from 50W to Several kW, Adaptive DirectSense™ Zero Voltage Switching
LTC1960	Dual Battery Charger/Selector with SPI Interface	Extends Run Time, Reduces Charging Time, Crisis Management Prevents Power Interruption, 36-Pin SSOP

PowerPath and DirectSense are trademarks of Linear Technology Corporation.