

FEATURES

- Sample Rate: 2.2MSPS
- Outstanding Spectral Purity:
80dB S/(N + D) and 95dB SFDR at 100kHz
78dB S/(N + D) and 84dB SFDR at Nyquist
- Ultralow Distortion with Single-Ended or Differential Inputs
- $\pm 2.5\text{V}$ Bipolar Input Range Eliminates Level Shifting and Rail-to-Rail Op Amp Requirements
- Easy Hookup for External or Internal Reference
- No Pipeline Delay
- Power Dissipation: 175mW on $\pm 5\text{V}$ Supplies
- 28-Pin Narrow SSOP Package

APPLICATIONS

- Telecommunications
- Digital Signal Processing
- Multiplexed Data Acquisition Systems
- High Speed Data Acquisition
- Spectrum Analysis
- Imaging Systems

DESCRIPTION

The LTC[®]1414 is a 14-bit, 2.2MSPS, sampling A/D converter which draws only 175mW from $\pm 5\text{V}$ supplies. This high performance ADC includes a high dynamic range sample-and-hold, a precision reference and requires no external components.

The LTC1414's high performance sample-and-hold has a full-scale input range of $\pm 2.5\text{V}$. Outstanding AC performance includes 80dB S/(N + D) and 95dB SFDR with a 100kHz input. The performance remains high at the Nyquist input frequency of 1.1MHz with 78dB S/(N + D) and 84dB SFDR.

The unique differential input sample-and-hold can acquire single-ended or differential input signals up to its 40MHz bandwidth. The 70dB common mode rejection can eliminate ground loops and common mode noise by measuring signal differentially from the source

The ADC has a microprocessor compatible, 14-bit parallel output port. There is no pipeline delay in the conversion results.

 LTC and LT are registered trademarks of Linear Technology Corporation.

TYPICAL APPLICATION

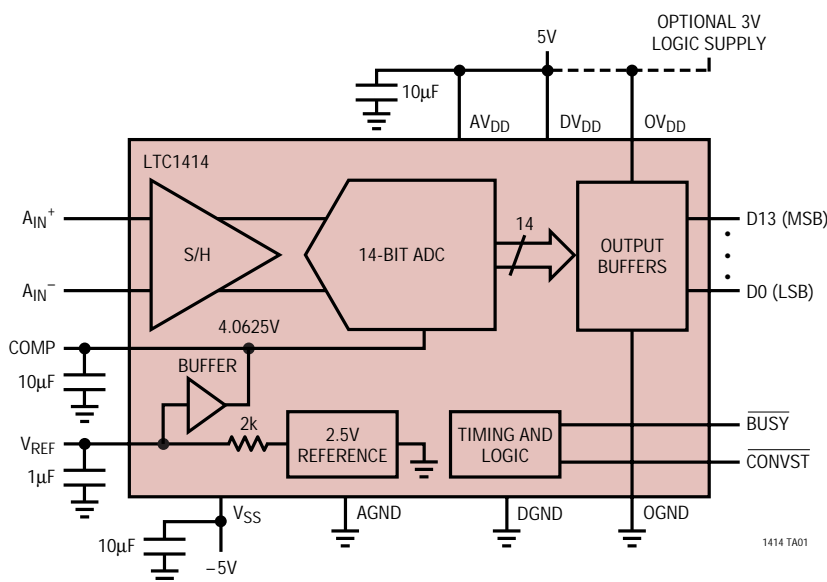

Effective Bits and Signal-to-Noise + Distortion vs Input Frequency

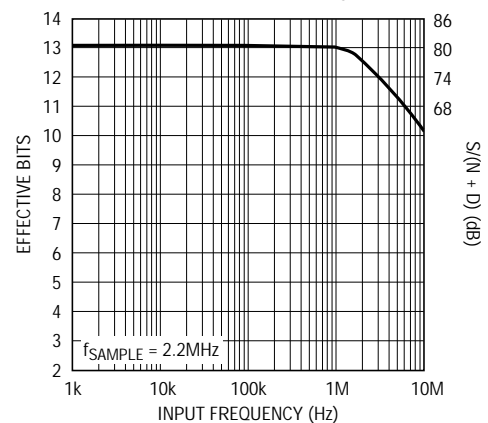

ABSOLUTE MAXIMUM RATINGS

$AV_{DD} = OV_{DD} = DV_{DD} = V_{DD}$ (Notes 1, 2)

Supply Voltage (V_{DD})	6V
Negative Supply Voltage (V_{SS})	-6V
Total Supply Voltage (V_{DD} to V_{SS})	12V
Analog Input Voltage	
(Note 3)	($V_{SS} - 0.3V$) to ($V_{DD} + 0.3V$)
Digital Input Voltage (Note 4)	($V_{SS} - 0.3V$) to 10V
Digital Output Voltage	($V_{SS} - 0.3V$) to ($V_{DD} + 0.3V$)
Power Dissipation	500mW
Operating Temperature Range	0°C to 70°C
Storage Temperature Range	-65°C to 150°C
Lead Temperature (Soldering, 10 sec)	300°C

PACKAGE/ORDER INFORMATION

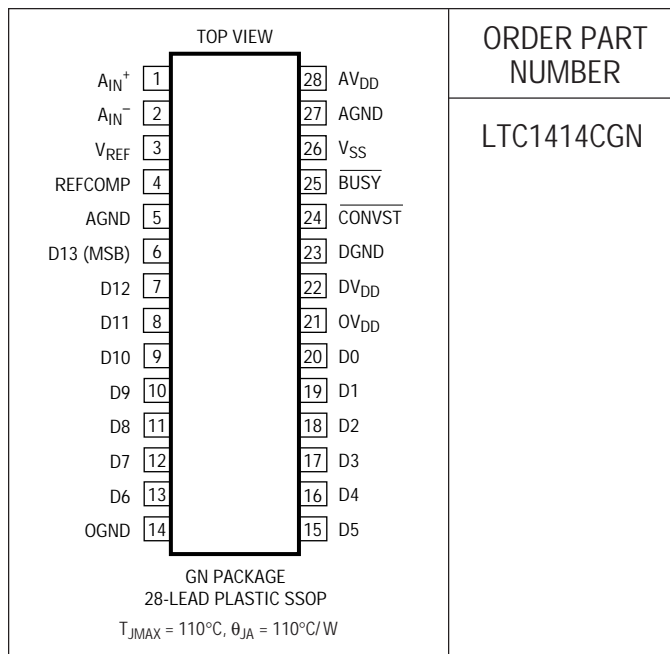

ORDER PART NUMBER

LTC1414CGN

Consult factory for Industrial, Military and A grade parts.

CONVERTER CHARACTERISTICS With internal reference (Notes 5, 6)

PARAMETER	CONDITIONS		LTC1414			UNITS
			MIN	TYP	MAX	
Resolution (No Missing Codes)		●	13			Bits
Integral Linearity Error	(Note 7)	●		±0.75	±2.0	LSB
Differential Linearity Error		●		±0.75	±1.75	LSB
Offset Error	(Note 8)	●		±5	±20 ±24	LSB LSB
Full-Scale Error	Internal Reference			±10	±60	LSB
	External Reference = 2.5V			±5	±25	LSB
Full-Scale Tempco	Internal Reference			±15		ppm/°C
	External Reference = 2.5V			±1		ppm/°C

ANALOG INPUT (Note 5)

SYMBOL	PARAMETER	CONDITIONS		MIN	TYP	MAX	UNITS
V_{IN}	Analog Input Range	$4.75V \leq V_{DD} \leq 5.25V, -5.25V \leq V_{SS} \leq -4.75V$	●		±2.5		V
I_{IN}	Analog Input Leakage Current	Between Conversions	●			±1	μA
C_{IN}	Analog Input Capacitance	Between Conversions			8		pF
		During Conversions			4		pF
t_{ACQ}	Sample-and-Hold Acquisition Time		●		40	100	ns
t_{AP}	Sample-and-Hold Aperture Delay Time				-1		ns
t_{jitter}	Sample-and-Hold Aperture Delay Time Jitter				3		ps _{RMS}
CMRR	Analog Input Common Mode Rejection Ratio	$-2.5V < (A_{IN-} - A_{IN+}) < 2.5V$			70		dB

DYNAMIC ACCURACY (Note 5)

SYMBOL	PARAMETER	CONDITIONS	MIN	TYP	MAX	UNITS
S/(N + D)	Signal-to-Noise Plus Distortion Ratio	100kHz Input Signal		80		dB
		1.1MHz Input Signal		78		dB
THD	Total Harmonic Distortion	100kHz Input Signal, First 5 Harmonics		-95		dB
		1.1MHz Input Signal, First 5 Harmonics		-83		dB
SFDR	Spurious Free Dynamic Range	100kHz Input Signal, First 5 Harmonics		95		dB
		1.1MHz Input Signal, First 5 Harmonics		84		dB
IMD	Intermodulation Distortion	$f_{IN1} = 29.37\text{kHz}$, $f_{IN2} = 32.446\text{kHz}$		-86		dB
		Full Power Bandwidth		40		MHz
		Full Linear Bandwidth	$S/(N + D) \geq 74\text{dB}$		3	

INTERNAL REFERENCE CHARACTERISTICS (Note 5)

PARAMETER	CONDITIONS	MIN	TYP	MAX	UNITS
V_{REF} Output Voltage	$I_{OUT} = 0$	2.480	2.500	2.520	V
V_{REF} Output Tempco	$I_{OUT} = 0$		± 15		ppm/°C
V_{REF} Line Regulation	$4.75\text{V} \leq V_{DD} \leq 5.25\text{V}$ $-5.25\text{V} \leq V_{SS} \leq -4.75\text{V}$		0.01		LSB/V
			0.01		LSB/V
V_{REF} Output Resistance	$ I_{OUT} \leq 0.1\text{mA}$		2		k Ω
COMP Output Voltage	$I_{OUT} = 0$		4.06		V

DIGITAL INPUTS AND OUTPUTS (Note 5)

SYMBOL	PARAMETER	CONDITIONS	MIN	TYP	MAX	UNITS
V_{IH}	High Level Input Voltage	$V_{DD} = 5.25\text{V}$	●	2.4		V
V_{IL}	Low Level Input Voltage	$V_{DD} = 4.75\text{V}$	●		0.8	V
I_{IN}	Digital Input Current	$V_{IN} = 0\text{V}$ to V_{DD}	●		± 10	μA
C_{IN}	Digital Input Capacitance			1.2		pF
V_{OH}	High Level Output Voltage	$V_{DD} = 4.75\text{V}$, $I_O = -10\mu\text{A}$	●	4.0	4.74	V
		$V_{DD} = 4.75\text{V}$, $I_O = -200\mu\text{A}$				V
V_{OL}	Low Level Output Voltage	$V_{DD} = 4.75\text{V}$, $I_O = 160\mu\text{A}$	●	0.05	0.4	V
		$V_{DD} = 4.75\text{V}$, $I_O = 1.6\text{mA}$				V
I_{SOURCE}	Output Source Current	$V_{OUT} = 0\text{V}$		-10		mA
I_{SINK}	Output Sink Current	$V_{OUT} = V_{DD}$		10		mA

POWER REQUIREMENTS (Note 5)

SYMBOL	PARAMETER	CONDITIONS	MIN	TYP	MAX	UNITS
V_{DD}	Positive Supply Voltage	(Note 9)		4.75	5.25	V
V_{SS}	Negative Supply Voltage	(Note 9)		-4.75	-5.25	V
I_{DD}	Positive Supply Current	$\overline{\text{CS}}$ High	●	12	16	mA
I_{SS}	Negative Supply Current	$\overline{\text{CS}}$ High	●	23	30	mA
P_D	Power Dissipation			175	230	mW

TIMING CHARACTERISTICS (Note 5)

SYMBOL	PARAMETER	CONDITIONS	MIN	TYP	MAX	UNITS	
$f_{\text{SAMPLE(MAX)}}$	Maximum Sampling Frequency		●	2.2		MHz	
t_{CONV}	Conversion Time		●	220	330	400	ns
t_{ACQ}	Acquisition Time		●	40	100		ns
$t_{\text{THROUGHPUT}}$	Throughput Time (Acquisition + Conversion)		●	370	454		ns
t_1	$\overline{\text{CONVST}}$ to $\overline{\text{BUSY}}$ Delay	$C_L = 25\text{pF}$		10			ns
t_2	Data Ready Before $\overline{\text{BUSY}}\uparrow$			± 20			ns
t_3	Delay Between Conversions	(Note 9)	●	100			ns
t_4	$\overline{\text{CONVST}}$ Low Time	(Note 10)	●	40			ns
t_5	$\overline{\text{CONVST}}$ High Time	(Note 10)	●	40			ns
t_6	Aperture Delay of Sample-and-Hold			-1			ns

The ● denotes specifications which apply over the full operating temperature range; all other limits and typicals $T_A = 25^\circ\text{C}$.

Note 1: Absolute Maximum Ratings are those values beyond which the life of a device may be impaired.

Note 2: All voltage values are with respect to ground with DGND and AGND wired together (unless otherwise noted).

Note 3: When these pin voltages are taken below V_{SS} or above V_{DD} , they will be clamped by internal diodes. This product can handle input currents greater than 100mA below V_{SS} or above V_{DD} without latchup.

Note 4: When these pin voltages are taken below V_{SS} , they will be clamped by internal diodes. This product can handle input currents greater than 100mA below V_{SS} without latchup. These pins are not clamped to V_{DD} .

Note 5: $V_{DD} = 5\text{V}$, $V_{SS} = -5\text{V}$, $f_{\text{SAMPLE}} = 2.2\text{MHz}$ and $t_r = t_f = 5\text{ns}$ unless otherwise specified.

Note 6: Linearity, offset and full-scale specifications apply for a single-ended A_{IN+} input with A_{IN-} grounded.

Note 7: Integral nonlinearity is defined as the deviation of a code from a straight line passing through the actual endpoints of the transfer curve. The deviation is measured from the center of the quantization band.

Note 8: Bipolar offset is the offset voltage measured from -0.5LSB when the output code flickers between 0000 0000 0000 00 and 1111 1111 1111 11.

Note 9: Recommended operating conditions.

Note 10: The falling $\overline{\text{CONVST}}$ edge starts a conversion. If $\overline{\text{CONVST}}$ returns high at a critical point during the conversion it can create small errors. For best results ensure that $\overline{\text{CONVST}}$ returns high either within 225ns after the start of the conversion or after $\overline{\text{BUSY}}$ rises.

TYPICAL PERFORMANCE CHARACTERISTICS

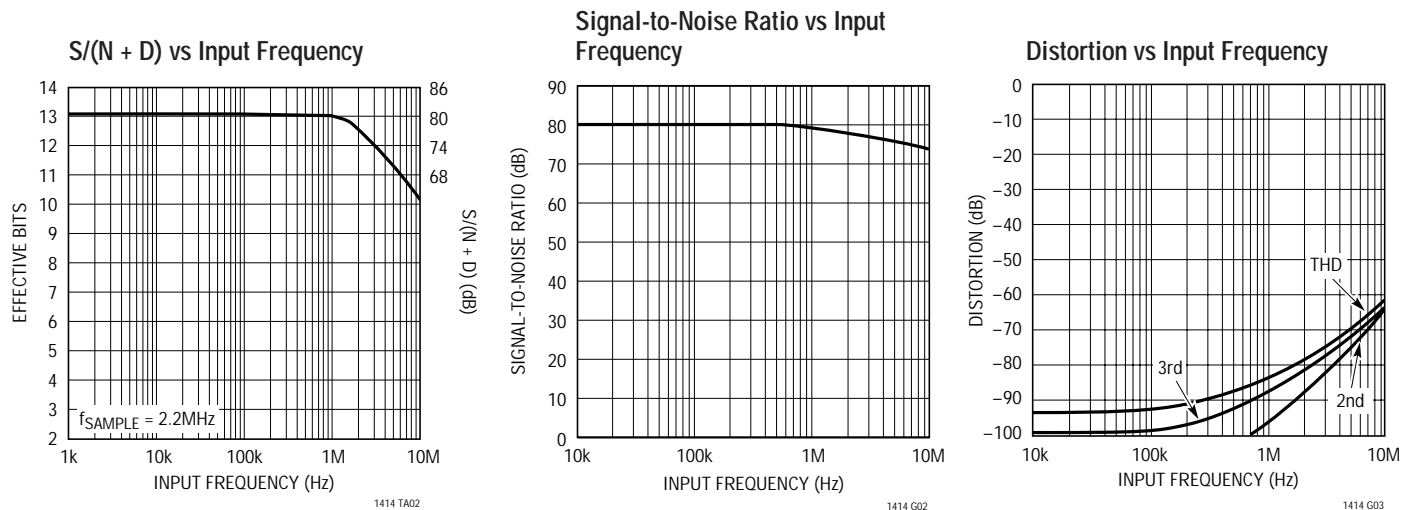

TYPICAL PERFORMANCE CHARACTERISTICS

Spurious-Free Dynamic Range vs Input Frequency

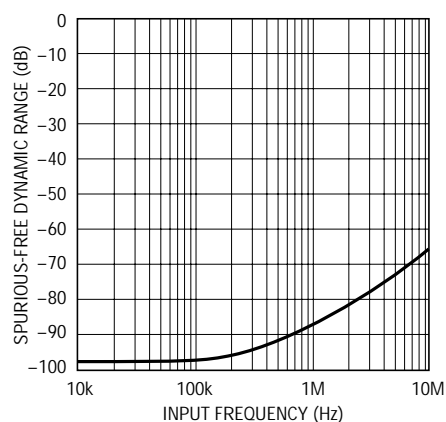

1414 G04

Intermodulation Distortion Plot

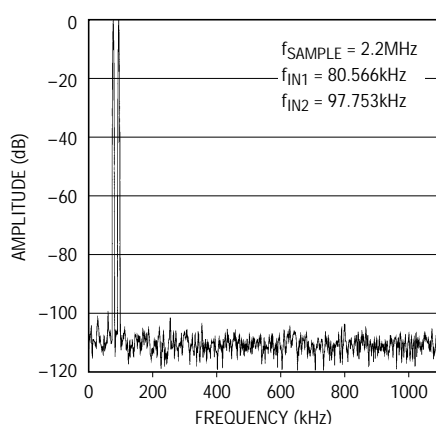

1414 F05a

Differential Nonlinearity vs Output Code

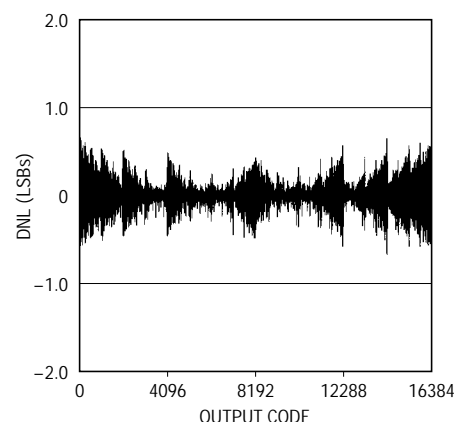

1414 G06

Integral Nonlinearity vs Output Code

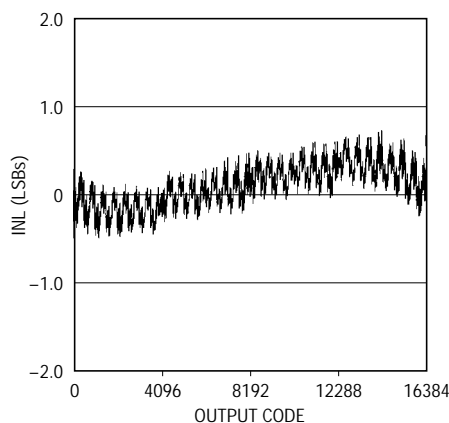

1414 G07

Power Supply Feedthrough vs Ripple Frequency

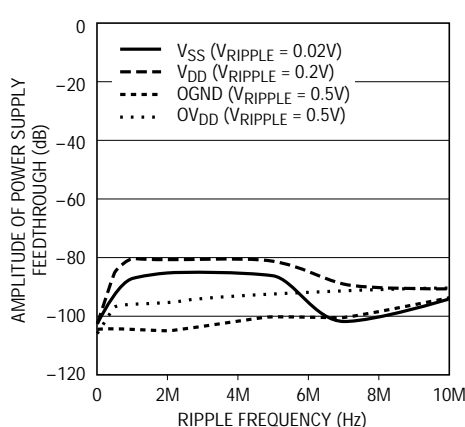

1414 G08

Input Common Mode Rejection vs Input Frequency

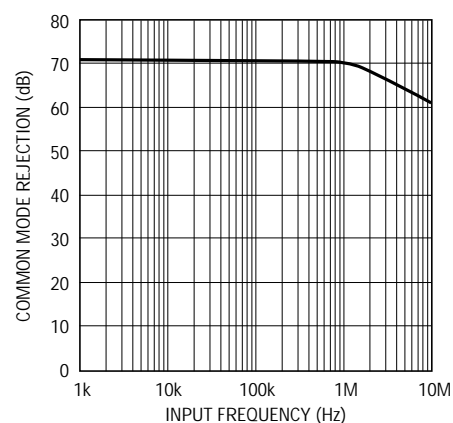

LTC1414-F12

PIN FUNCTIONS

A_{IN}^+ (Pin 1): Positive Analog Input. $\pm 2.5\text{V}$ input range when A_{IN}^- is grounded. $\pm 2.5\text{V}$ differential if A_{IN}^- is driven differentially with A_{IN}^+ .

A_{IN}^- (Pin 2): Negative Analog Input. Can be grounded or driven differentially with A_{IN}^+ .

V_{REF} (Pin 3): 2.5V Reference Output.

REFCOMP (Pin 4): 4.06V Reference Bypass Pin. Bypass to AGND with $10\mu\text{F}$ ceramic or $10\mu\text{F}$ tantalum in parallel with $0.1\mu\text{F}$ ceramic.

AGND (Pin 5): Analog Ground.

D13 to D6 (Pins 6 to 13): Data Outputs.

OGND (Pin 14): Digital Ground for the Output Drivers. Tie to AGND

D5 to D0 (Pins 15 to 20): Data Outputs.

OV_{DD} (Pin 21): Positive Supply for the Output Drivers. Tie to Pin 28 when driving 5V logic. For 3V logic, tie to supply of the logic being driven.

DV_{DD} (Pin 22): 5V Positive Supply. Tie to Pin 28.

DGND (Pin 23): Digital Ground. Tie to AGND.

CONVST (Pin 24): Conversion Start Signal. This active low signal starts a conversion on its falling edge.

PIN FUNCTIONS

BUSY (Pin 25): The $\overline{\text{BUSY}}$ Output Shows the Converter Status. It is low when a conversion is in progress.

V_{SS} (Pin 26): -5V Negative Supply. Bypass to AGND with 10 μF ceramic or 10 μF tantalum in parallel with 0.1 μF ceramic.

AGND (Pin 27): Analog Ground.

AV_{DD} (Pin 28): 5V Positive Supply. Bypass to AGND with 10 μF ceramic or 10 μF tantalum in parallel with 0.1 μF ceramic.

FUNCTIONAL BLOCK DIAGRAM

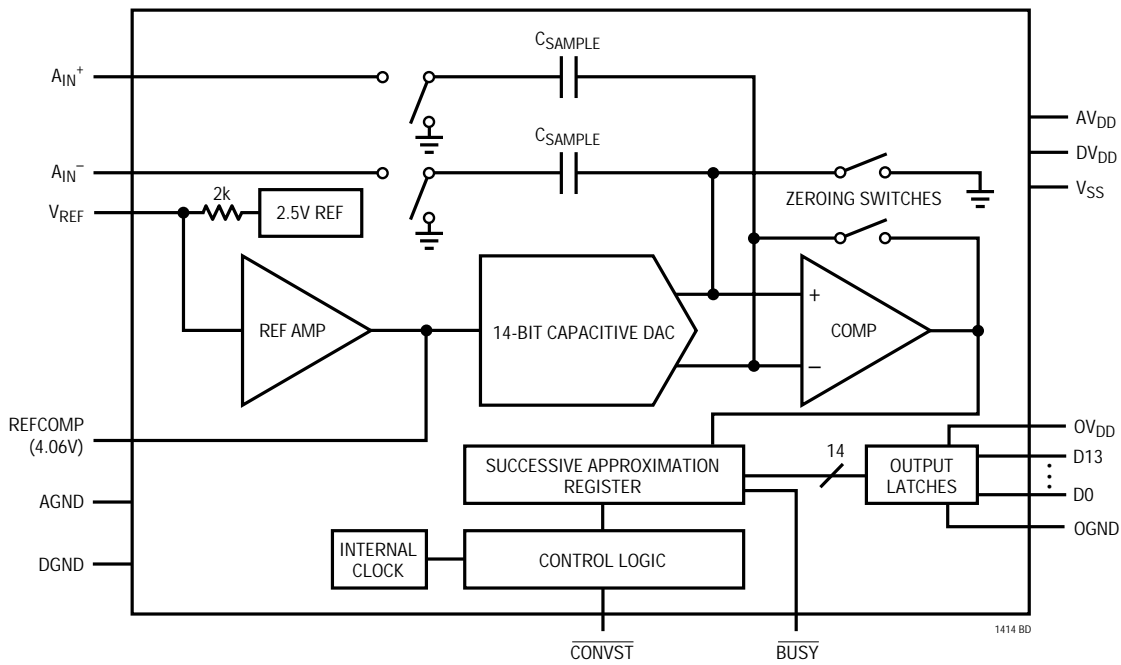

TIMING DIAGRAM

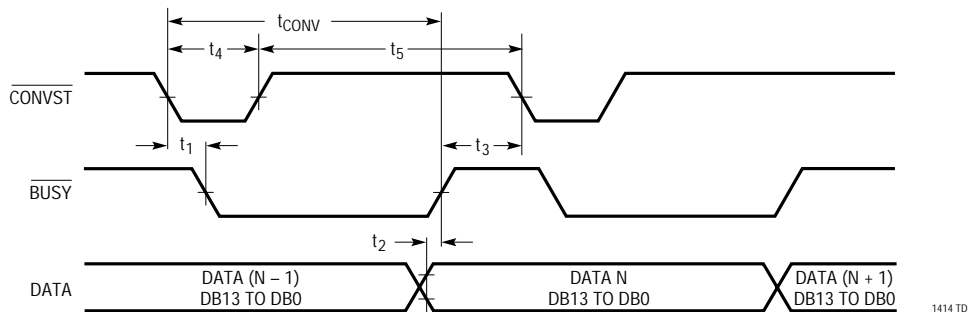

APPLICATIONS INFORMATION

CONVERSION DETAILS

The LTC1414 uses a successive approximation algorithm and an internal sample-and-hold circuit to convert an analog signal to a 14-bit parallel output. The ADC is complete with a precision reference and an internal clock. The device is easy to interface with microprocessors and DSPs. (Please refer to the Digital Interface section for the data format.)

Conversion start is controlled by the $\overline{\text{CONVST}}$ input. At the start of the conversion the successive approximation register (SAR) is reset. Once a conversion cycle has begun it cannot be restarted.

During the conversion, the internal differential 14-bit capacitive DAC output is sequenced by the SAR from the most significant bit (MSB) to the least significant bit (LSB). Referring to Figure 1, the A_{IN}^+ and A_{IN}^- inputs are connected to the sample-and-hold capacitors (C_{SAMPLE}) during the acquire phase, and the comparator offset is nulled by the zeroing switches. In this acquire phase, a minimum delay of 70ns will provide enough time for the sample-and-hold capacitors to acquire the analog signal. During the convert phase the comparator zeroing switches open, putting the comparator into compare mode. The input switches connect the C_{SAMPLE} capacitors to ground, transferring the differential analog input charge onto the summing junction. This input charge is successively compared with the binary-weighted charges supplied by the differential capacitive DAC. Bit decisions are made by the high speed comparator. At the end of a conversion, the differential DAC output balances the A_{IN}^+ and A_{IN}^- input charges. The SAR contents (a 14-bit data word) which represents the difference of A_{IN}^+ and A_{IN}^- are loaded into the 14-bit output latches.

DYNAMIC PERFORMANCE

The LTC1414 has excellent high speed sampling capability. FFT (Fast Four Transform) test techniques are used to test the ADC's frequency response, distortion and noise at the rated throughput. By applying a low distortion sine wave and analyzing the digital output using an FFT algorithm, the ADC's spectral content can be examined for frequencies outside the fundamental. Figure 2 shows a typical LTC1414 FFT plot.

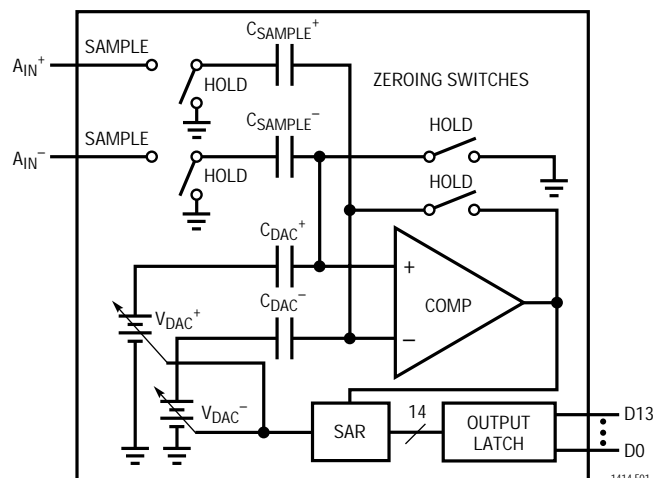
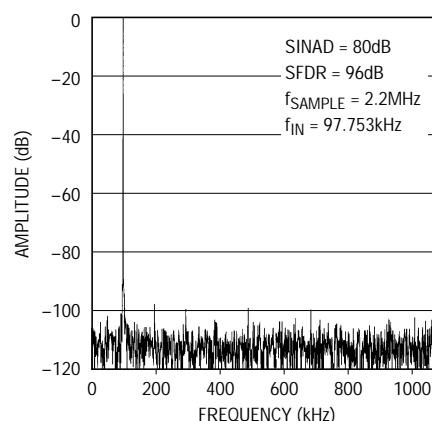

Figure 1. Simplified Block Diagram

Signal-to-Noise Ratio

The signal-to-(noise + distortion) ratio $[S/(N + D)]$ is the ratio between the RMS amplitude of the fundamental input frequency to the RMS amplitude of all other frequency components at the A/D output. The output is band limited to frequencies from above DC and below half the sampling frequency. Figure 2a shows a typical spectral content with a 2.2MHz sampling rate and a 100kHz input. The dynamic performance is excellent for input frequencies up to and beyond the Nyquist limit of 1.1MHz. (See Figure 2b)



1414 F02a

Figure 2a. LTC1414 Nonaveraged, 2048 Point FFT, Input Frequency = 100kHz

APPLICATIONS INFORMATION

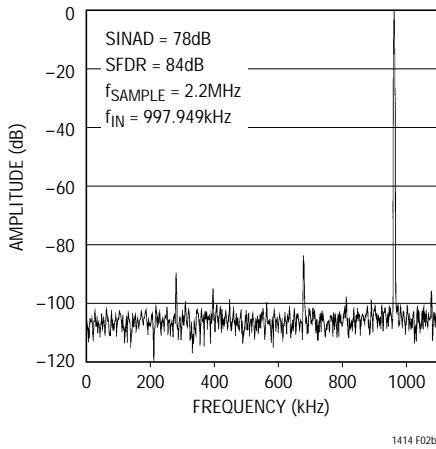

Figure 2b. LTC1414 2048 Point FFT, Input Frequency = 1MHz

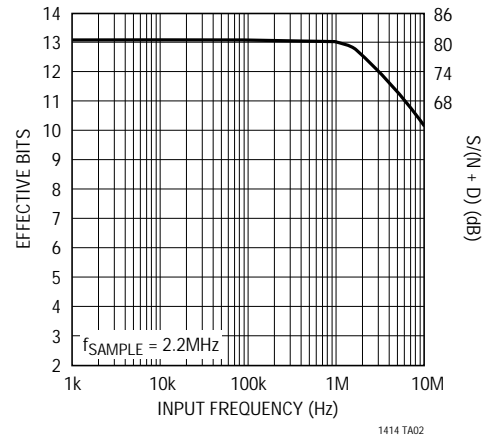

Figure 3. Effective Bits and Signal/(Noise + Distortion) vs Input Frequency

Effective Number of Bits

The effective number of bits (ENOBs) is a measurement of the resolution of an ADC and is directly related to the $S/(N + D)$ by the equation:

$$ENOB_S = [S/(N + D) - 1.76]/6.02$$

where $S/(N + D)$ is expressed in dB. At the maximum sampling rate of 2.2MHz the LTC1414 maintains near ideal ENOBs up to the Nyquist input frequency of 1.1MHz. Refer to Figure 3.

Total Harmonic Distortion

Total harmonic distortion (THD) is the ratio of the RMS sum of all harmonics of the input signal to the fundamental itself. The out-of-band harmonics alias into the frequency band between DC and half the sampling frequency. THD is expressed as:

$$THD = 20 \log \frac{\sqrt{V_2^2 + V_3^2 + V_4^2 + \dots + V_N^2}}{V_1}$$

where V_1 is the RMS amplitude of the fundamental frequency and V_2 through V_N are the amplitudes of the second through Nth harmonics. THD vs input frequency is shown in Figure 4. The LTC1414 has good distortion performance up to the Nyquist frequency and beyond.

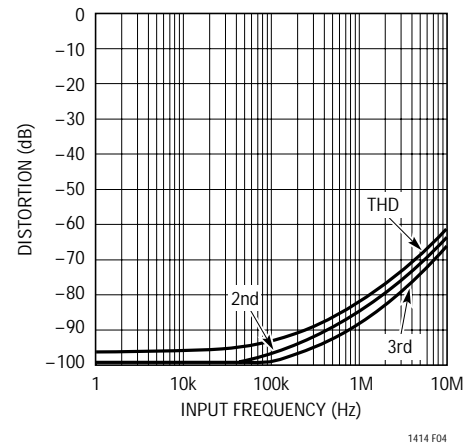

Figure 4. Distortion vs Input Frequency

Intermodulation Distortion

If the ADC input signal consists of more than one spectral component, the ADC transfer function nonlinearity can produce intermodulation distortion (IMD) in addition to the THD. IMD is the change in one sinusoidal input caused by the presence of another sinusoidal input at a different frequency.

If two pure sine waves of frequencies f_a and f_b are applied to the ADC input, nonlinearities in the ADC transfer function can create distortion products at the sum and difference frequencies of $mf_a \pm nf_b$, where m and $n = 0, 1, 2, 3$ etc. For example, the 2nd order IMD terms include $(f_a \pm f_b)$. If the two input sine waves are equal in magnitude, the value (in dB) of the 2nd order IMD products can be expressed by the following formula:

APPLICATIONS INFORMATION

$$\text{IMD}(f_a \pm f_b) = 20 \log \left[\frac{\text{amplitude at } (f_a \pm f_b)}{\text{amplitude at } f_a} \right]$$

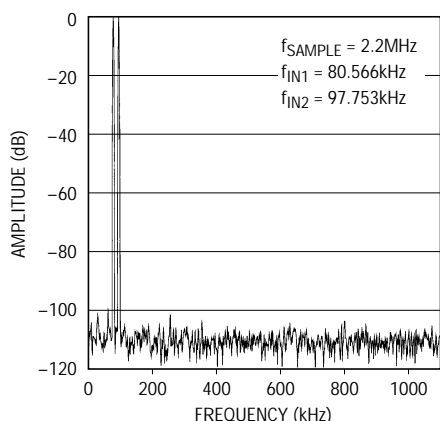

Figure 5a. Intermodulation Distortion Plot with Inputs at 80kHz and 97kHz

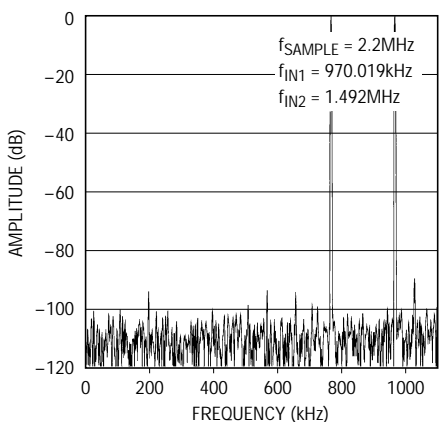

Figure 5b. Intermodulation Distortion Plot with Input Signals of 1MHz and 1.5MHz

Peak Harmonic or Spurious Noise

The peak harmonic or spurious noise is the largest spectral component excluding the input signal and DC. This value is expressed in dB relative to the RMS value of a full-scale input signal.

Full-Power and Full-Linear Bandwidth

The full-power bandwidth is that input frequency at which the amplitude of the reconstructed fundamental is reduced by 3db for a full-scale input signal.

The full-linear bandwidth is the input frequency at which the $S/(N + D)$ has dropped to 74dB (12 effective bits). The LTC1414 has been designed to optimize input bandwidth, allowing the ADC to undersample input signals with frequencies above the converter's Nyquist frequency. The noise floor stays very low at high frequencies; $S/(N + D)$ becomes dominated by distortion at frequencies far beyond Nyquist.

Driving the Analog Input

The differential analog inputs of the LTC1414 are easy to drive. The inputs may be driven differentially or as a single-ended input (i.e., the A_{IN}^- input is grounded). The A_{IN}^+ and A_{IN}^- inputs are sampled at the same instant. Any unwanted signal that is common mode to both inputs will be reduced by the common mode rejection of the sample-and-hold circuit. The inputs draw only one small current spike while charging the sample-and-hold capacitors at the end of conversion. During conversion, the analog inputs draw only a small leakage current. If the source impedance of the driving circuit is low then the LTC1414 inputs can be driven directly. As source impedance increases so will acquisition time (see Figure 6). For minimum acquisition time, with high source impedance, a buffer amplifier should be used. The only requirement is that the amplifier driving the analog input(s) must settle after the small current spike before the next conversion starts (settling time must be 70ns for full throughput rate).

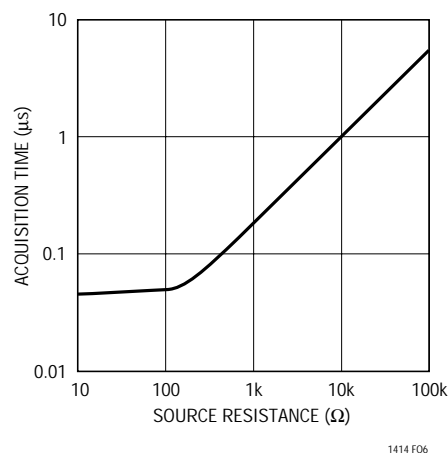

Figure 6. Acquisition Time vs Source Resistance

APPLICATIONS INFORMATION

Choosing an Input Amplifier

Choosing an input amplifier is easy if a few requirements are taken into consideration. First, to limit the magnitude of the voltage spike seen by the amplifier from charging the sampling capacitor, choose an amplifier that has a low output impedance ($<100\Omega$) at the closed-loop bandwidth frequency. For example, if an amplifier is used in a gain of 1 and has a unity-gain bandwidth of 50MHz, then the output impedance at 50MHz must be less than 100Ω . The second requirement is that the closed-loop bandwidth must be greater than 40MHz to ensure adequate small-signal settling for full throughput rate. If slower op amps are used, more settling time can be provided by increasing the time between conversions.

The best choice for an op amp to drive the LTC1414 will depend on the application. Generally applications fall into two categories: AC applications where dynamic specifications are most critical and time domain applications where DC accuracy and settling time are most critical. The following list is a summary of the op amps that are suitable for driving the LTC1414. More detailed information is available in the Linear Technology Databooks and on the LinearView™ CD-ROM.

LT®1223: 100MHz Video Current Feedback Amplifier. 6mA supply current. $\pm 5V$ to $\pm 15V$ supplies. Low noise. Good for AC applications.

LT1227: 140MHz Video Current Feedback Amplifier. 10mA supply current. $\pm 5V$ to $\pm 15V$ supplies. Low noise. Best for AC applications.

LT1229/LT1230: Dual and Quad 100MHz Current Feedback Amplifiers. $\pm 2V$ to $\pm 15V$ supplies. Low noise. Good AC specifications, 6mA supply current each amplifier.

LT1360: 50MHz Voltage Feedback Amplifier. 3.8mA supply current. Good AC and DC specs. $\pm 5V$ to $\pm 15V$ supplies. 70ns settling to 0.5LSB.

LT1363: 70MHz, 1000V/ μs Op Amps. 6.3mA supply current. Good AC and DC specifications. 60ns settling to 0.5LSB.

LT1364/LT1365: Dual and Quad 70MHz, 1000V/ μs Op Amps. 6.3mA supply current per amplifier. 60ns settling to 0.5LSB.

AC Coupled Inputs

In applications where only the AC component of the analog input is important, it may be desirable to AC couple the input. This is easily accomplished by DC biasing the LTC1414 analog input with a resistor to ground and using a coupling capacitor to the input. Figure 7 shows a simple AC coupled input circuit for the LTC1414 using only two additional components. C1 is a $10\mu F$ ceramic capacitor and R1 is a 1000Ω resistor to ground. R1 and C1 form a highpass filter with a lower cut off frequency of $1/2\pi(C1)R1$ or 15.9Hz.

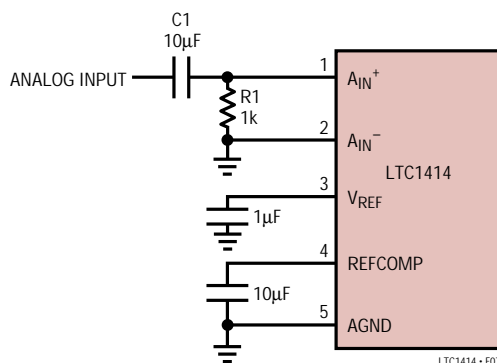

Figure 7. AC Coupled Input

Differential Drive

In some applications the ADC drive circuitry is differential. The differential drive can be applied directly to the LTC1414 without any special translation circuitry. Differential drive can be advantageous at high frequencies ($>1MHz$) since it provides improved THD and SFDR. Transformers can be used to provide AC coupling, input scaling and single ended to differential conversion as shown in Figure 8. The resistor R_S across the secondary will determine the input impedance on the primary. The input impedance of the primary R_P will be related to the secondary load resistor R_S by the equation

$$R_P = R_S/n^2$$

For example, if a Minicircuits T4-6T transformer is used, the turns ratio is 2; if R_S is 200Ω then R_P is equal to 50Ω .

The center tap of the secondary will set the common mode voltage and should be grounded for optimal AC performance.

APPLICATIONS INFORMATION

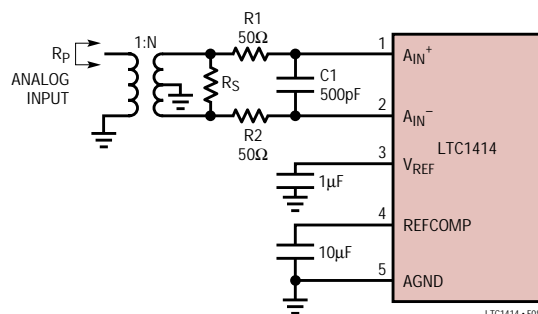

Figure 8. If a Transformer Coupled Input is Required, this Circuit Provides a Simple Solution

Input Filtering

The noise and the distortion of the input amplifier and other circuitry must be considered since they will add to the LTC1414 noise and distortion. The small-signal bandwidth of the sample-and-hold circuit is 40MHz. Any noise or distortion products that are present at the analog inputs will be summed over this entire bandwidth. Noisy input circuitry should be filtered prior to the analog inputs to minimize noise. A simple 1-pole RC filter is sufficient for many applications.

For example, Figure 9 shows a 500pF capacitor from A_{IN}^+ to ground and a 100Ω source resistor to limit the input bandwidth to 3.2MHz. The 500pF capacitor also acts as a charge reservoir for the input sample-and-hold and isolates the ADC input from sampling glitch-sensitive circuitry. High quality capacitors and resistors should be used since poor quality components can add distortion. NPO and silver mica type dielectric capacitors have excellent linearity. Carbon surface mount resistors can also generate distortion from self heating and from damage that may occur during soldering. Metal film surface mount resistors are much less susceptible to both problems.

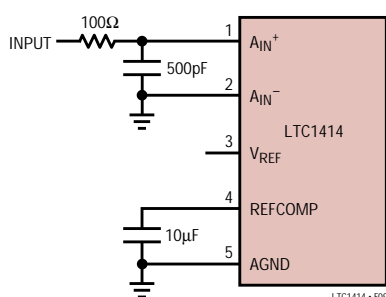

Figure 9. An RC Filter Reduces the ADC's 40MHz Bandwidth to 3.2MHz and Filters Out Wideband Noise Which May Be Present in the Input Signal

Input Range

The $\pm 2.5V$ input range of the LTC1414 is optimized for low noise and low distortion. Most op amps also perform best over this same range, allowing direct coupling to the analog inputs and eliminating the need for special translation circuitry.

Some applications may require other input ranges. The LTC1414 differential inputs and reference circuitry can accommodate other input ranges often with little or no additional circuitry. The following sections describe the reference and input circuitry and how they affect the input range.

Internal Reference

The LTC1414 has an on-chip, temperature compensated, curvature corrected, bandgap reference that is factory trimmed to 2.500V. It is connected internally to a reference amplifier and is available at V_{REF} (Pin 3), see Figure 10. A 2k resistor is in series with the output so that it can be easily overdriven by an external reference or other circuitry. The reference amplifier multiplies the voltage at the V_{REF} pin by 1.625 to create the required internal reference voltage. This provides buffering between the V_{REF} pin and the high speed capacitive DAC. The reference amplifier compensation pin, REFCOMP (Pin 4) must be bypassed with a capacitor to ground. The reference amplifier is stable with capacitors of 1μF or greater. For the best noise performance, a 10μF ceramic or 10μF tantalum in parallel with a 0.1μF ceramic is recommended.

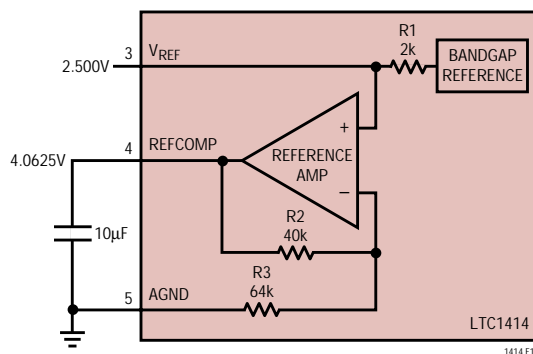

Figure 10. LTC1414 Reference Circuit

APPLICATIONS INFORMATION

The V_{REF} pin can be driven with a DAC or other means shown in Figure 11. This is useful in applications where the peak input signal amplitude may vary. The input span of the ADC can then be adjusted to match the peak input signal, maximizing the signal-to-noise ratio. The filtering of the internal LTC1414 reference amplifier will limit the bandwidth and settling time of this circuit. A settling time of 5ms should be allowed after a reference adjustment.

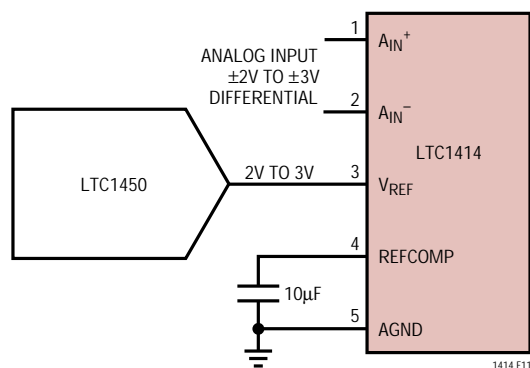

Figure 11. Driving V_{REF} with a DAC

Differential Inputs

The LTC1414 has a unique differential sample-and-hold circuit that allows rail-to-rail inputs. The ADC will always convert the difference of $A_{IN}^+ - (A_{IN}^-)$ independent of the common mode voltage. The common mode rejection holds up to extremely high frequencies, see Figure 12. The only requirement is that neither input can exceed the AV_{DD} or AV_{SS} power supply voltages. Integral nonlinearity errors (INL) and differential nonlinearity errors (DNL) are independent of the common mode voltage, however, the bipolar zero error (BZE) will vary. The change in BZE is typically less than 0.1% of the common mode voltage. Dynamic performance is also affected by the common mode voltage. THD will degrade as the inputs approach either power supply rail, from -84dB with a common mode of 0V to -75dB with a common mode of 2.5V or -2.5V .

Full-Scale and Offset Adjustment

Figure 13 shows the ideal input/output characteristics for the LTC1414. The code transitions occur midway between successive integer LSB values (i.e., $-FS + 0.5\text{LSB}$, $-FS + 1.5\text{LSB}$, $-FS + 2.5\text{LSB}$, ... $FS - 2.5\text{LSB}$, $FS - 1.5\text{LSB}$).

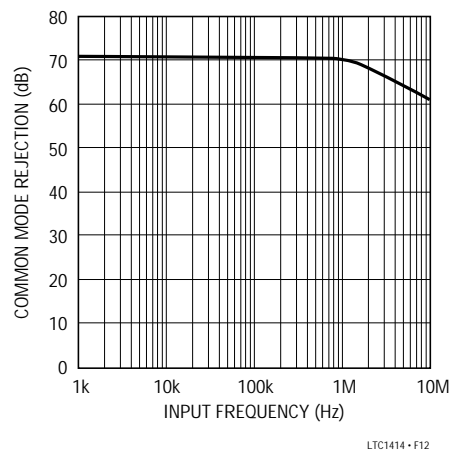

Figure 12. CMRR vs Input Frequency

The output is two's complement binary with $1\text{LSB} = FS - (-FS)/16384 = 5\text{V}/16384 = 305.2\mu\text{V}$.

In applications where absolute accuracy is important, offset and full-scale errors can be adjusted to zero. Offset error must be adjusted before full-scale error. Figure 14 shows the extra components required for full-scale error adjustment. Zero offset is achieved by adjusting the offset applied to the A_{IN}^- input. For zero offset error apply $-152\mu\text{V}$ (i.e., -0.5LSB) at A_{IN}^+ and adjust the offset at the A_{IN}^- input until the output code flickers between 0000 0000 00 and 1111 1111 1111 11. For full-scale adjustment, an input voltage of 2.499544V ($FS - 1.5\text{LSBs}$) is applied to A_{IN}^+ and R2 is adjusted until the output code flickers between 0111 1111 1111 10 and 0111 1111 1111 11.

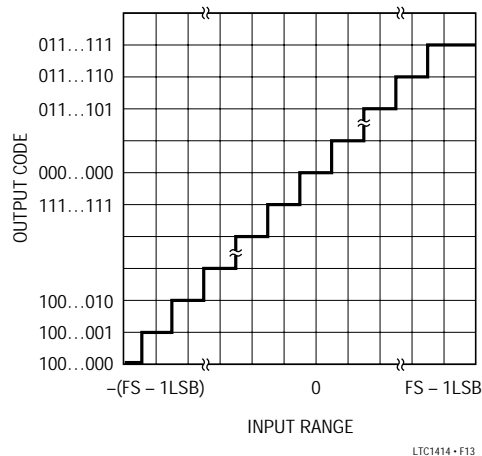

Figure 13. LTC1414 Transfer Characteristics

APPLICATIONS INFORMATION

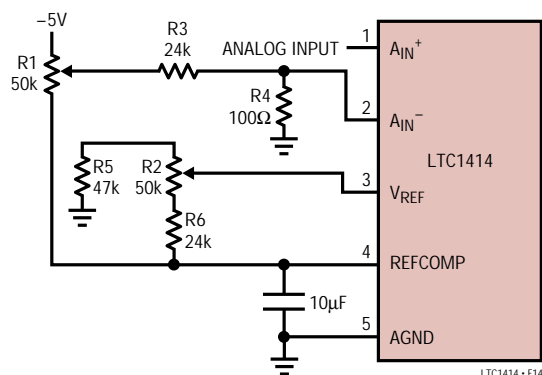

Figure 14. Offset and Full-Scale Adjust Circuit

Board Layout and Bypassing

To obtain the best performance from the LTC1414, a printed circuit board with a ground plane is required. Layout for the printed circuit board should ensure that digital and analog signal lines are separated as much as possible. In particular, care should be taken not to run any digital line alongside an analog signal line or underneath the ADC. The analog input should be screened by AGND.

High quality tantalum and ceramic bypass capacitors should be used at the V_{DD} , V_{SS} and V_{REF} pins. Bypass capacitors must be located as close to the pins as possible. The traces connecting the pins and bypass capacitors must be kept short and should be made as wide as possible.

The LTC1414 has differential inputs to minimize noise coupling. Common mode noise on the A_{IN}^+ and A_{IN}^- inputs will be reflected by the input CMRR. The A_{IN}^- input can be used as a ground sense for the A_{IN}^+ input; the LTC1414 will hold and convert the difference voltage between A_{IN}^+ and A_{IN}^- . The leads to A_{IN}^+ (Pin 1) and A_{IN}^- (Pin 2) should be kept as short as possible. In applications where this is not possible, the A_{IN}^+ and A_{IN}^- traces should be run side by side to equalize coupling.

A single point analog ground separate from the logic system ground should be established with an analog ground plane at AGND (Pin 5, 27) or as close as possible to the ADC (see Figure 8). The ADC's DGND (Pin 23) and all other analog grounds should be connected to this single analog ground point. No other digital grounds should be connected to this analog ground point. Low impedance analog and digital power supply common returns are essential to low noise operation of the ADC and these traces should be as wide as possible. Excessive capacitive loading on the ADC's data output lines can generate large transient currents on the ADC supplies which may affect conversion results. In these cases, the use of digital buffers is recommended to isolate the ADC from the excessive loading.

EXAMPLE LAYOUT

Figures 16a, 16b, 16c and 16d show the schematic and layout of an evaluation board. The layout demonstrates the proper use of decoupling capacitors and ground plane with a two layer printed circuit board.

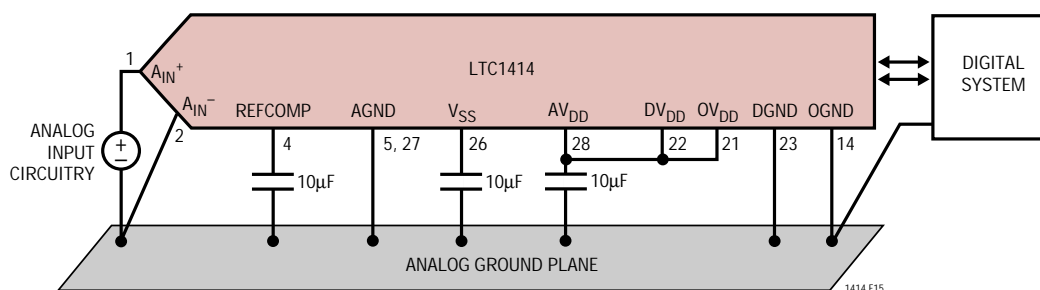

Figure 15. Power Supply Grounding Practice

APPLICATIONS INFORMATION

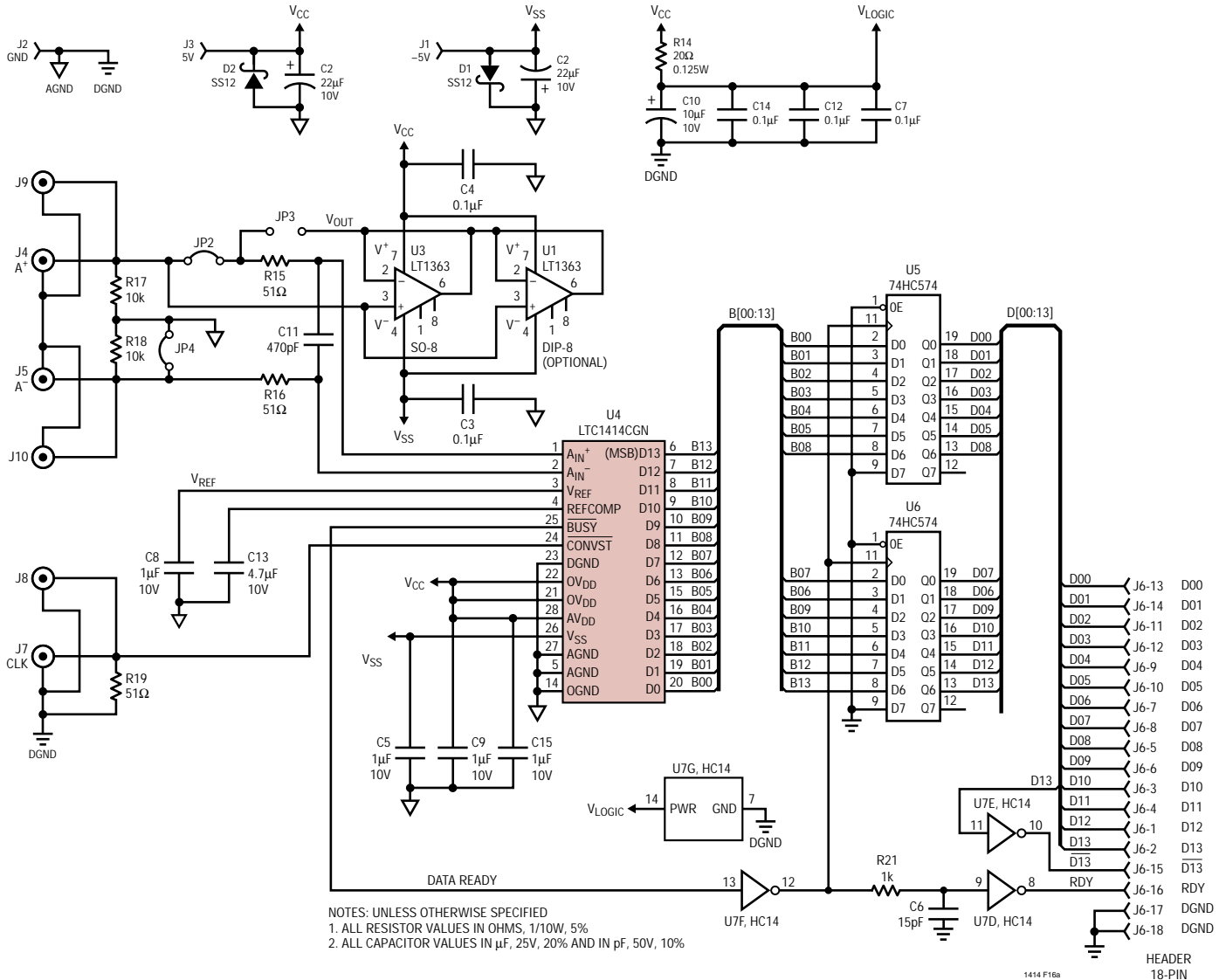

Figure 16a. Evaluation Circuit Schematic

APPLICATIONS INFORMATION

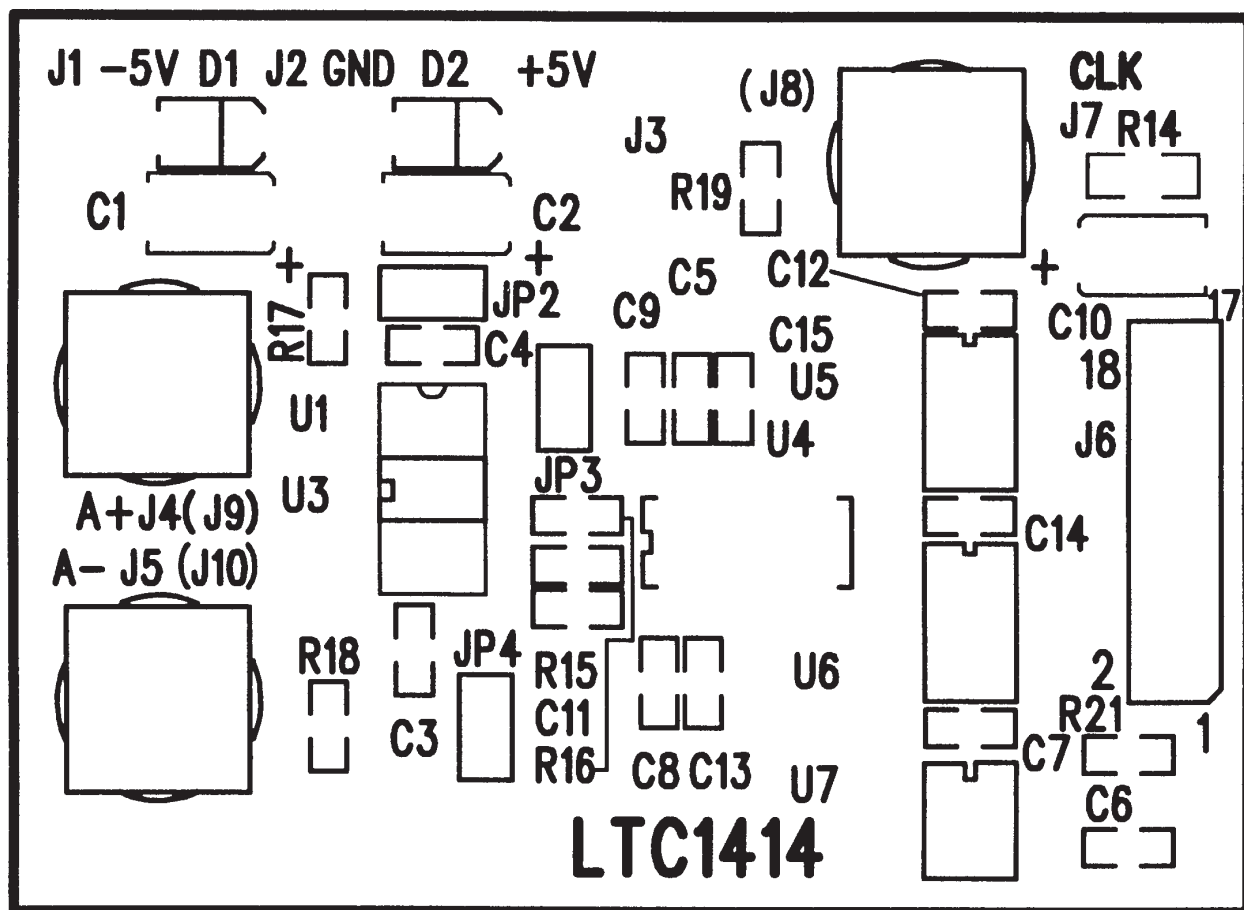

Figure 16b. Evaluation Circuit Board Component Side Silkscreen

APPLICATIONS INFORMATION

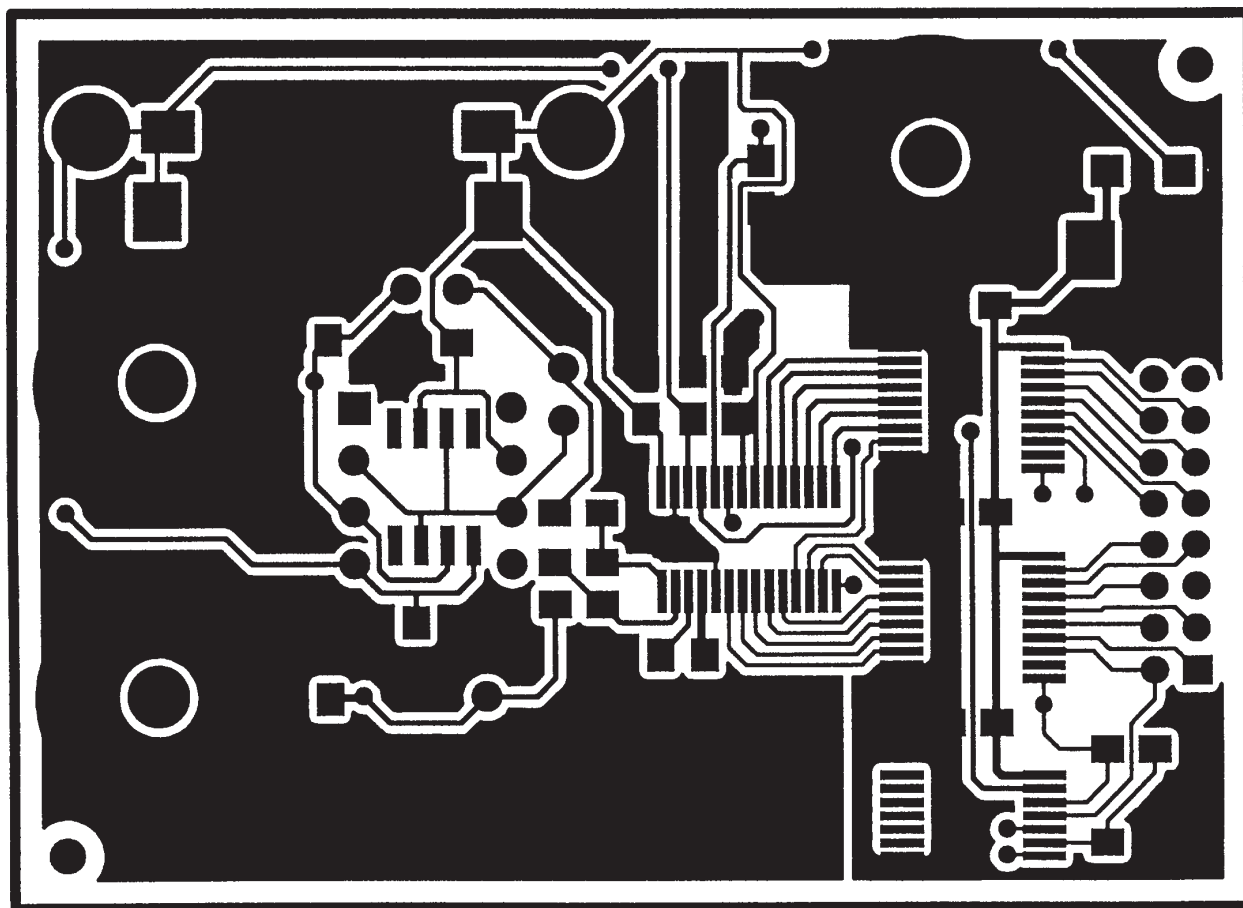

Figure 16c. Evaluation Circuit Board Component Side Layout

APPLICATIONS INFORMATION

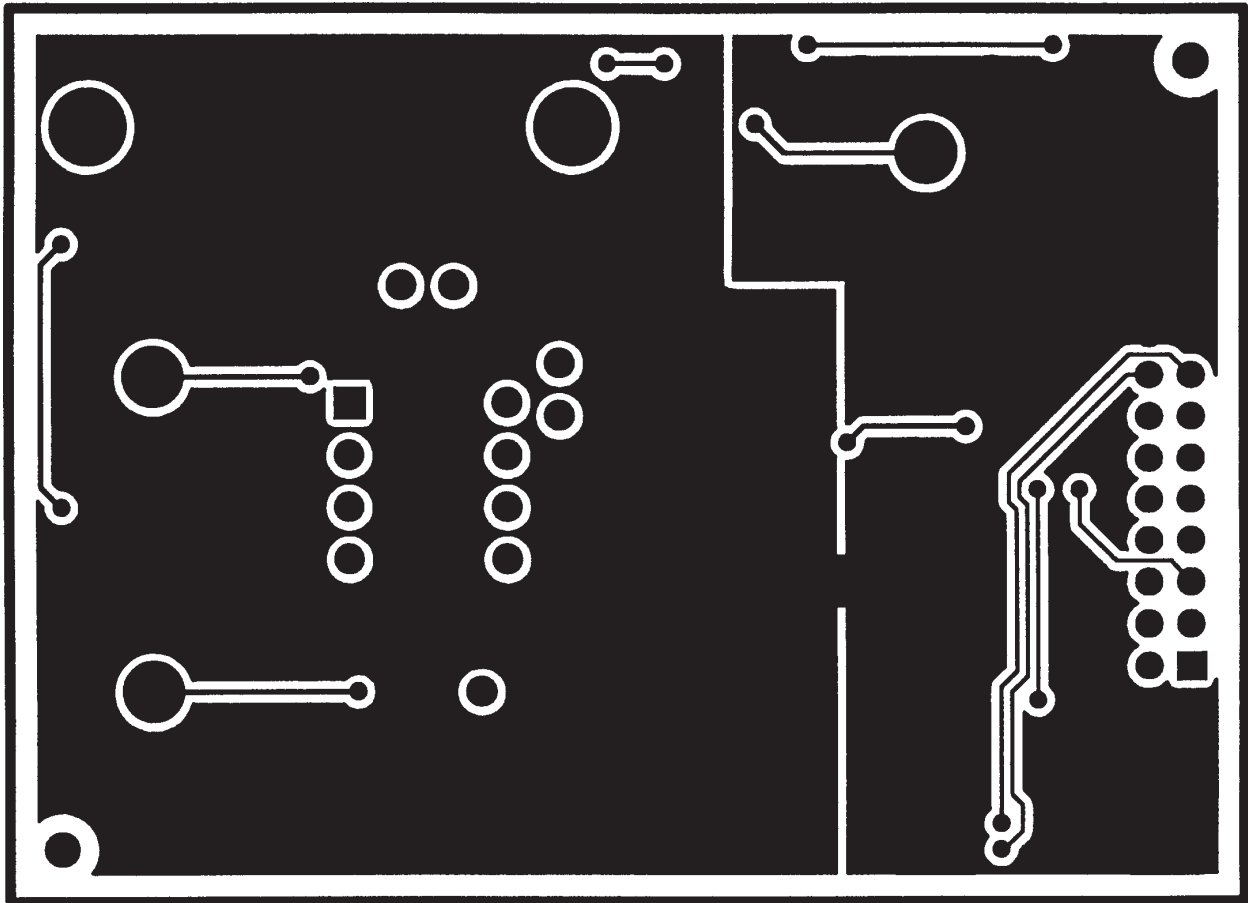

Figure 16d. Evaluation Circuit Board Solder Side Layout

APPLICATIONS INFORMATION

Digital Interface

The A/D converter has just one control input $\overline{\text{CONVST}}$. Data is output on 14-bit parallel bus. An additional output $\overline{\text{BUSY}}$ indicates the converter status.

DIGITAL OUTPUTS

The parallel digital outputs of the LTC1414 are designed to interface to TTL and CMOS logic. The output data is two's complement coded.

The output drivers have a separate power pin (OV_{DD}) and ground pin (OGND). This allows relatively noisy output ground and the output supply bypass ground to be separated from the other ADC grounds. Additionally, the OV_{DD} pin may be driven by the supply of the logic that is being driven. For example, the OV_{DD} supply may be 3V while LTC1414 DV_{DD} and AV_{DD} pins are 5V, allowing 3V logic to be driven directly.

Care should be taken to not load the digital outputs with excessive capacitance. Large capacitive loads result in large charging currents which can cause conversion errors. It is recommended that the capacitive loading is kept under 20pF. If it is not possible to keep the capacitance low, a buffer or latch may be used to isolate the LTC1414 from the capacitive load.

Timing and Control

The conversion start is controlled by the $\overline{\text{CONVST}}$ input. The falling edge of $\overline{\text{CONVST}}$ will start a conversion. Once initiated, it cannot be restarted until the conversion is complete. Converter status is indicated by the $\overline{\text{BUSY}}$ output. $\overline{\text{BUSY}}$ is low during a conversion.

The output data is updated at the end of the conversion as $\overline{\text{BUSY}}$ rises. Output data is updated coincident with the rising edge of $\overline{\text{BUSY}}$. Data will be valid, and can be latched, 20ns after the rising edge of $\overline{\text{BUSY}}$. Valid data can also be latched with the falling edge of $\overline{\text{BUSY}}$ or with the rising edge of $\overline{\text{CONVST}}$. In the latter two cases the data latched will be for the previous conversion.

$\overline{\text{CONVST}}$ Drive Considerations

Timing jitter of the $\overline{\text{CONVST}}$ signal can adversely affect the noise performance of the LTC1414 when the input signal contains high slew rate components. The falling edge of $\overline{\text{CONVST}}$ determines the sampling instant. Any uncertainty in this sampling instant will translate to voltage noise when a fast changing input signal is being sampled. For a full amplitude sinusoidal input, the relationship between timing jitter (t_{jitter}) and SNR_j is

$$\text{SNR}_j = 20 \log(1/2\pi \cdot f_{\text{IN}} \cdot t_{\text{jitter}})$$

where SNR_j is the signal-to-jitter noise ratio.

The internal circuitry of the LTC1414 has been optimized for ultralow jitter (typically 3ps RMS). The external clock drive circuitry is equally important and must also have low jitter to achieve low noise.

Internal Clock

The internal clock is factory trimmed to achieve a typical conversion time of 330ns and a maximum conversion time over the full operating temperature range of 400ns. No external adjustments are required. The guaranteed maximum acquisition time is 100ns. In addition, a throughput time (acquisition + conversion) of 454ns and a minimum sampling rate of 2.2MSPS is guaranteed.

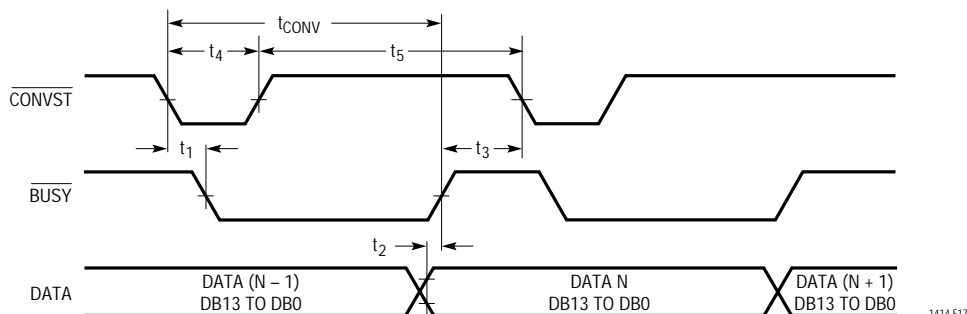
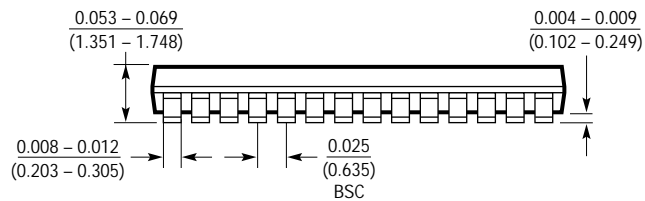
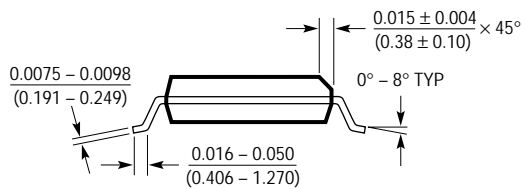
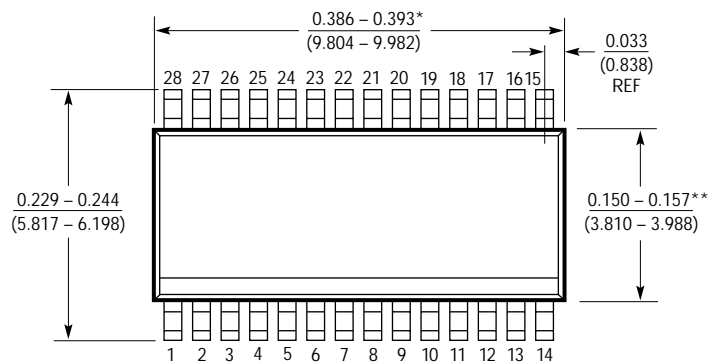

Figure 17. Timing Diagram

PACKAGE DESCRIPTION Dimensions in inches (millimeters) unless otherwise noted.

GN Package
28-Lead Plastic SSOP Narrow (0.150)
 (LTC DWG # 05-08-1641)



* DIMENSION DOES NOT INCLUDE MOLD FLASH. MOLD FLASH SHALL NOT EXCEED 0.006" (0.152mm) PER SIDE
 ** DIMENSION DOES NOT INCLUDE INTERLEAD FLASH. INTERLEAD FLASH SHALL NOT EXCEED 0.010" (0.254mm) PER SIDE

GN28 (SSOP) 0398

TYPICAL APPLICATION

2.2MHz, 14-Bit Sampling ADC

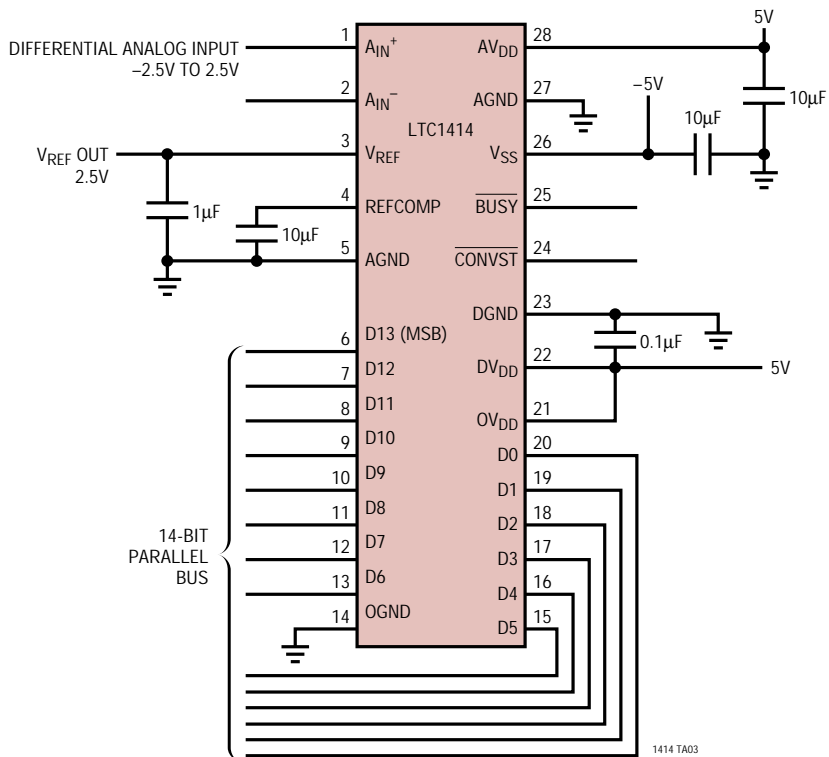

RELATED PARTS

PART NUMBER	DESCRIPTION	COMMENTS
LTC1412	Low Power, 12-Bit, 3Msps, ADC	Nyquist Sampling, 150mW, 72dB SINAD
LTC1415	Single 5V, 12-Bit, 1.25Msps, ADC	Single Supply, 55mW Dissipation
LTC1416	Low Power, 14-Bit, 400ksps, ADC	±5V Supplies, 75mW Dissipation
LTC1417	Very Low Power, 14-Bit, 400ksps, ADC	20mW, 5V or ±5V Supply, Serial I/O in 16-Pin SSOP
LTC1418	Very Low Power, 14-Bit, 200ksps, ADC	15mW, 5V or ±5V Supply, Serial or Parallel I/O
LTC1419	Low Power, 14-Bit, 800ksps, ADC	True 14-Bit Linearity, 81.5dB SINAD, 150mW Dissipation
LTC1604	High Speed, 16-Bit, 333ksps, ADC	90dB SINAD, -100dB THD, 220mW Dissipation
LT1460	Micropower Precision Series Reference	0.075% Accuracy, 10ppm/°C Drift