

20mA LED Driver and OLED Driver with Integrated Schottky in 3mm x 2mm DFN

FEATURES

- **Dual Output Boost for Dual Display Devices**
- **Drives Up to Six White LEDs and OLED/LCD Bias**
- Internal Power Switches and Schottky Diodes
- Independent Dimming and Shutdown
- 200mV High Side Sense on LED Driver Allows “One-Wire Current Source”
- Wide Input Voltage Range: 2.5V to 12V
- Wide Output Voltage Range: Up to 32V
- 2.3MHz PWM Frequency for LED Driver
- PFM for OLED Driver is Non-Audible Over Entire Load Range
- Open LED Protection (27V Maximum on CAP1 Pin)
- OLED Output Disconnect
- Available in 12-Pin DFN Package
- 1mm Tall Solution Height

APPLICATIONS

- Cellular Phones
- PDAs, Handheld Computers
- Digital Cameras
- MP3 Players
- GPS Receivers

DESCRIPTION

The LT[®]3498 is a dual output boost converter featuring a 2.3MHz PWM LED Driver and PFM OLED Driver. It includes an internal power switch and Schottky diode for each driver. Both converters can be independently shut down and modulated. This highly integrated power solution is ideal for dual display electronic devices.

The 2.3MHz step-up converter is designed to drive up to six white LEDs in series from a Li-Ion cell. The device features a unique high side LED current sense that enables the part to function as a “one-wire” current source—one side of the LED string can be returned to ground anywhere. Traditional LED drivers use a grounded resistor to sense LED current, requiring a 2-wire connection to the LED string.

The PFM OLED driver is a low noise boost converter that features a novel control technique.* The converter controls power delivery by varying both the peak inductor current and switch off time. This technique results in low output voltage ripple, as well as, high efficiency over a wide load range. The off time of the switch is not allowed to exceed a fixed level, guaranteeing a switching frequency that stays above the audio band.

LT, **LT**, **LTC** and **LTM** are registered trademarks of Linear Technology Corporation. All other trademarks are the property of their respective owners.

*Patent Pending

TYPICAL APPLICATION

Li-Ion to Six White LEDs and OLED/LCD Bias

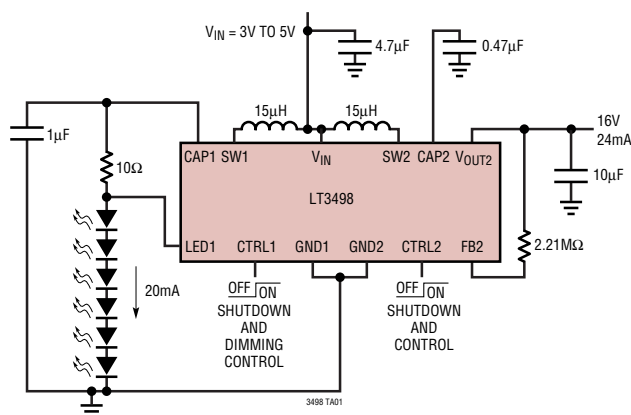

OLED Efficiency

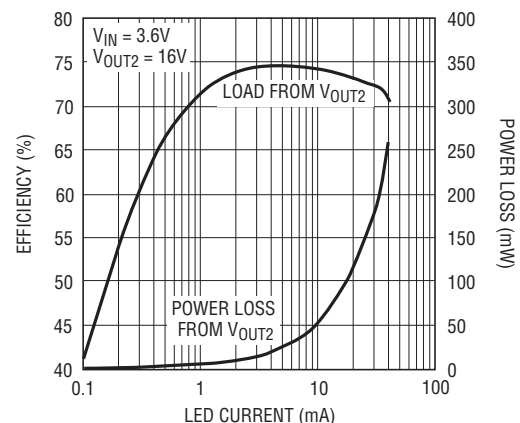

ABSOLUTE MAXIMUM RATINGS

(Notes 1, 2)

Input Voltage (V_{IN}).....	12V
CTRL1 and CTRL2 Voltage.....	12V
FB2 Voltage.....	2.5V
V_{OUT2} Voltage.....	32V
SW1 and SW2 Voltage.....	32V
CAP1 and CAP2 Voltage.....	32V
LED1 Voltage.....	32V
Operating Junction Temperature Range...	-40°C to 85°C
Maximum Junction Temperature.....	125°C
Storage Temperature Range.....	-65°C to 150°C

PACKAGE/ORDER INFORMATION

TOP VIEW

DDB PACKAGE
12-LEAD (3mm × 2mm) PLASTIC DFN
 $T_{JMAX} = 125^{\circ}\text{C}$, $\theta_{JA} = 160^{\circ}\text{C/W}$
EXPOSED PAD (PIN 13) IS GND, MUST BE SOLDERED TO PCB

ORDER PART NUMBER	DDB PART MARKING
LT3498EDDB	LCQF

Order Options Tape and Reel: Add #TR
Lead Free: Add #PBF Lead Free Tape and Reel: Add #TRPBF
Lead Free Part Marking: <http://www.linear.com/leadfree/>

Consult LTC Marketing for parts specified with wider operating temperature ranges.

ELECTRICAL CHARACTERISTICS

The ● denotes the specifications which apply over the full operating temperature range, otherwise specifications are at $T_A = 25^{\circ}\text{C}$, $V_{IN} = 3\text{V}$, $V_{CTRL1} = V_{CTRL2} = 3\text{V}$.

PARAMETER	CONDITIONS	MIN	TYP	MAX	UNITS
Minimum Operating Voltage		2.5			V
Maximum Operating Voltage				12	V
Supply Current (LED Off, OLED Off)	$V_{IN} = 3\text{V}$, $V_{CTRL1} = 0\text{V}$, $V_{CTRL2} = 0\text{V}$		8	10	μA
Supply Current (LED On, OLED Off)	$V_{IN} = 3\text{V}$, $V_{CTRL1} = 3\text{V}$, $V_{CTRL2} = 0\text{V}$, $V_{CAP1} = 24\text{V}$, $V_{LED1} = 23\text{V}$		1.6	2	mA
Supply Current (LED Off, OLED On)	$V_{IN} = 3\text{V}$, $V_{CTRL1} = 0\text{V}$, $V_{CTRL2} = 3\text{V}$, $V_{FB2} = 3\text{V}$		230	280	μA
Supply Current (LED On, OLED On)	$V_{IN} = 3\text{V}$, $V_{CTRL1} = 3\text{V}$, $V_{CTRL2} = 3\text{V}$, $V_{CAP1} = 24\text{V}$, $V_{LED1} = 23\text{V}$		1.65	2.05	mA
V_{CTRL1} for Full LED Current V_{CTRL2} for Full OLED Brightness		● 1.5			V
V_{CTRL1} or V_{CTRL2} to Turn On I_C		● 125			mV
V_{CTRL1} and V_{CTRL2} to Shut Down I_C				75	mV
CTRL1, CTRL2 Pin Bias Current			100		nA
LED Driver					
LED Current Sense Voltage ($V_{CAP} - V_{LED}$)	$V_{CAP1} = 24\text{V}$, $I_{SW} = 200\text{mA}$	● 190	200	210	mV
CAP1, LED1 Pin Bias Current	$V_{CAP1} = 16\text{V}$, $V_{LED1} = 16\text{V}$		20	30	μA
V_{CAP1} , V_{LED1} Common Mode Minimum Voltage				2.5	V
Switching Frequency		● 1.8	2.3	2.8	MHz
Maximum Duty Cycle		88	90		%
Switch Current Limit		● 300	425		mA
Switch V_{CESAT}	$I_{SW} = 200\text{mA}$		250		mV

3498f

ELECTRICAL CHARACTERISTICS The ● denotes the specifications which apply over the full operating temperature range, otherwise specifications are at $T_A = 25^\circ\text{C}$, $V_{IN} = 3\text{V}$, $V_{CTRL1} = V_{CTRL2} = 3\text{V}$.

PARAMETER	CONDITIONS		MIN	TYP	MAX	UNITS
Switch Leakage Current	$V_{SW1} = 16\text{V}$			0.1	5	μA
CAP1 Pin Overvoltage Protection			26	27	28	V
Schottky Forward Voltage	$I_{SCHOTTKY1} = 100\text{mA}$			0.8		V
Schottky Reverse Leakage	$V_{REVERSE1} = 20\text{V}$				6	μA
OLED Driver						
Feedback Voltage	$V_{CTRL2} = 3\text{V}$ (Note 3)	●	1.18	1.215	1.25	V
Feedback Resistor		●	177	182	186	$\text{k}\Omega$
Minimum Switch Off Time	After Start-Up			150		ns
Minimum Switch Off Time	During Start-Up (Note 4)			1		μs
Maximum Switch Off Time	$V_{FB2} = 1.5\text{V}$	●	15	20	30	μs
Switch Current Limit			180	300	400	mA
Switch V_{CESAT}	$I_{SW2} = 200\text{mA}$			260		mV
Switch Leakage Current	$V_{SW2} = 16\text{V}$			0.1	5	μA
Schottky Forward Voltage	$I_{SCHOTTKY2} = 100\text{mA}$			800		mV
Schottky Reverse Leakage	$V_{REVERSE2} = 20\text{V}$				2	μA
PMOS Disconnect $V_{CAP2} - V_{OUT2}$	$I_{OUT2} = 10\text{mA}$, $V_{CAP2} = 5\text{V}$			250		mV
CTRL2 to FB2 Offset	$V_{CTRL2} = 0.5\text{V}$			8	15	mV
Maximum Shunt Current	$V_{FB2} = 1.3\text{V}$			220		μA

Note 1: Stresses beyond those listed under Absolute Maximum Ratings may cause permanent damage to the device. Exposure to any Absolute Maximum Rating condition for extended periods may affect device reliability and lifetime.

Note 2: The LT3498 is guaranteed to meet performance specifications from 0°C to 85°C . Specifications over the -40°C to 85°C junction operating temperature range are assured by design, characterization and correlation with statistical process controls.

Note 3: Internal reference voltage is determined by finding V_{FB2} voltage level which causes quiescent current to increase $20\mu\text{A}$ above “Not Switching” level.

Note 4: If CTRL2 is overriding the internal reference, start-up mode occurs when V_{FB2} is less than half the voltage on CTRL2. If CTRL2 is not overriding the internal reference, start-up mode occurs when V_{FB2} is less than half the voltage of the internal reference.

TYPICAL PERFORMANCE CHARACTERISTICS $T_A = 25^\circ\text{C}$, unless otherwise specified.

Shutdown Current
($V_{CTRL1} = V_{CTRL2} = 0\text{V}$)

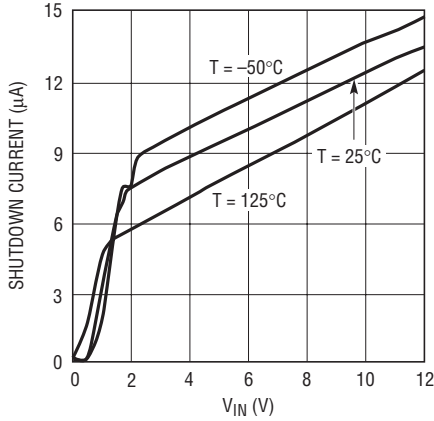

1635 G07

LED Switch Saturation Voltage (V_{CESAT1})

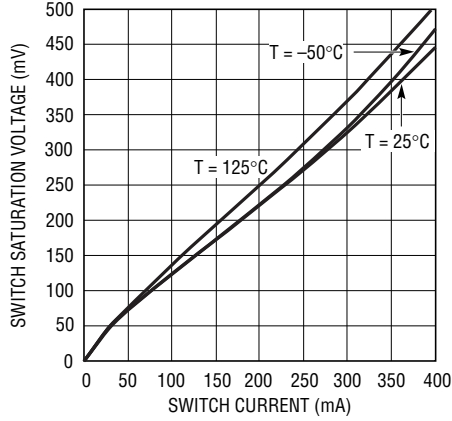

3498 G02

LED Schottky Forward Voltage Drop

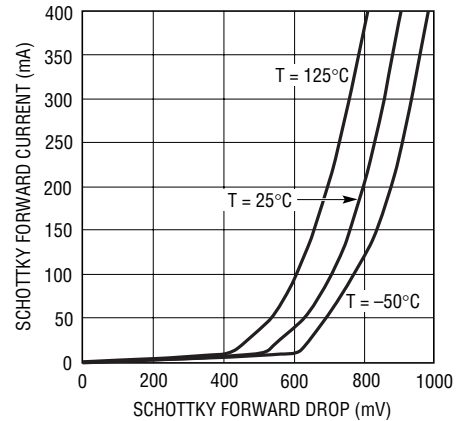

3498 G03

Sense Voltage ($V_{CAP1} - V_{LED1}$) vs V_{CTRL1}

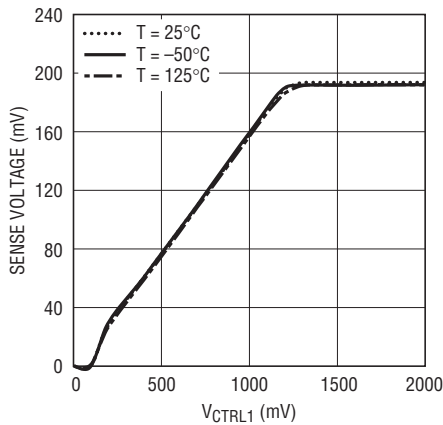

3498 G04

Sense Voltage ($V_{CAP1} - V_{LED1}$) vs Temperature

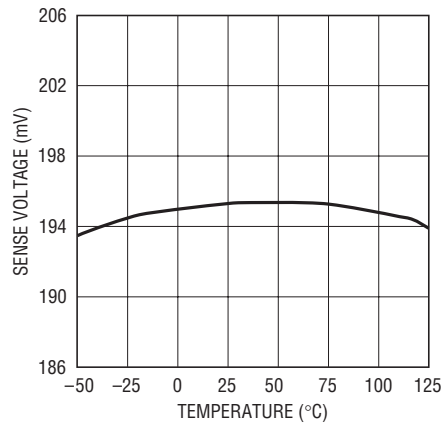

3498 G05

Sense Voltage ($V_{CAP1} - V_{LED1}$) vs V_{CAP1}

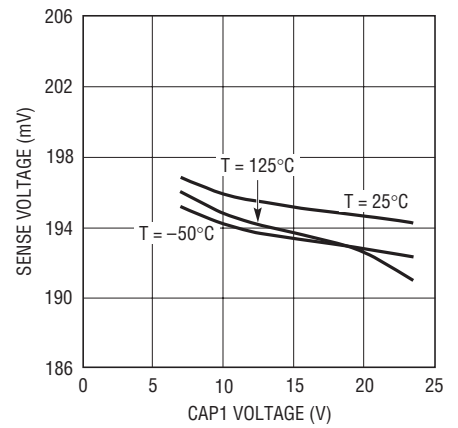

3498 G06

LED Current Limit vs Temperature

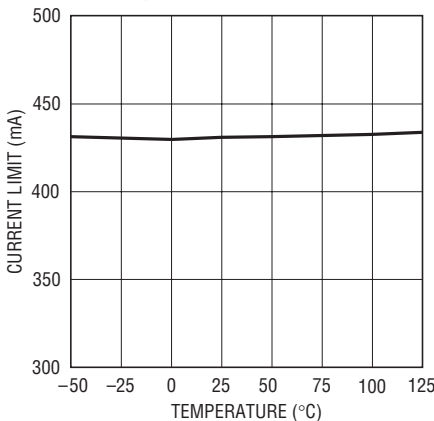

3498 G07

Open Circuit Output Clamp Voltage

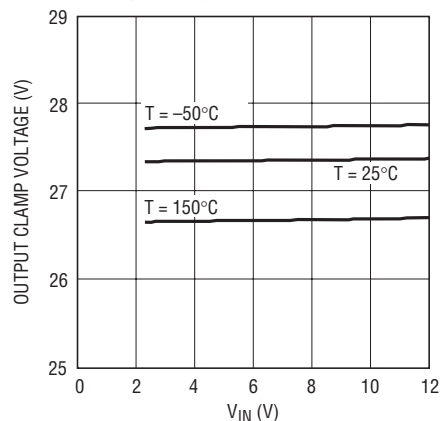

3498 G08

Input Current in Output Open Circuit

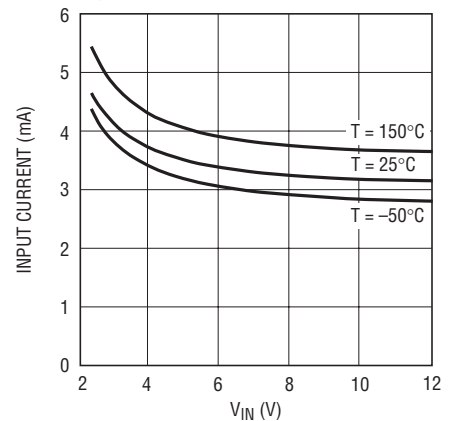

3498 G09

TYPICAL PERFORMANCE CHARACTERISTICS $T_A = 25^\circ\text{C}$, unless otherwise specified.

LED Switching Frequency vs Temperature

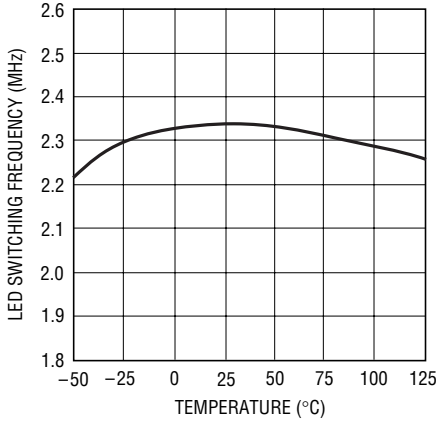

3498 G10

OLED Switch Saturation Voltage (V_{CESAT2})

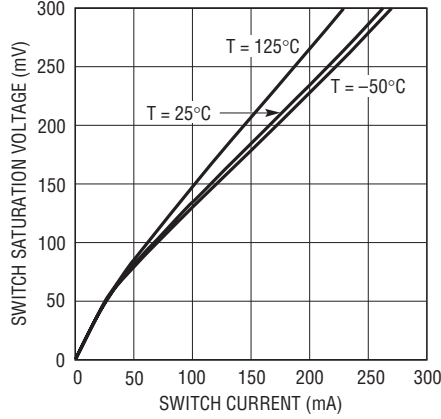

3498 G11

OLED Schottky Forward Voltage Drop

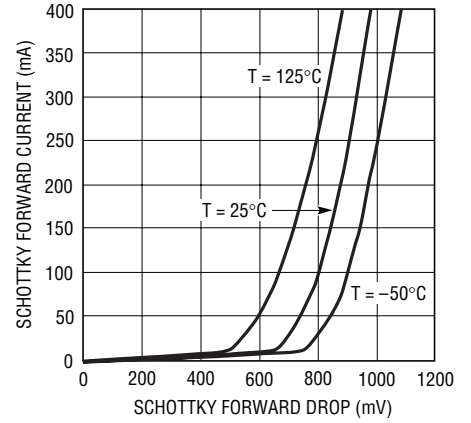

3498 G12

V_{OUT2} vs V_{CTRL2} ($V_{OUT2} = 16\text{V}$)

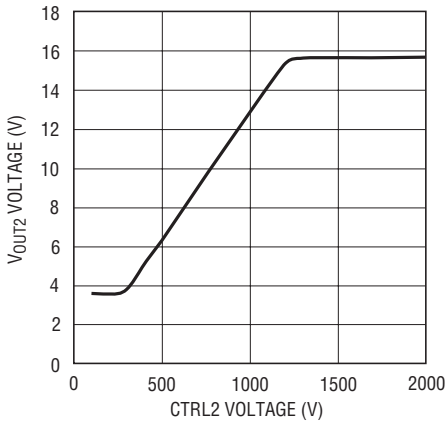

3498 G13

V_{OUT2} vs Temperature ($V_{OUT2} = 16\text{V}$)

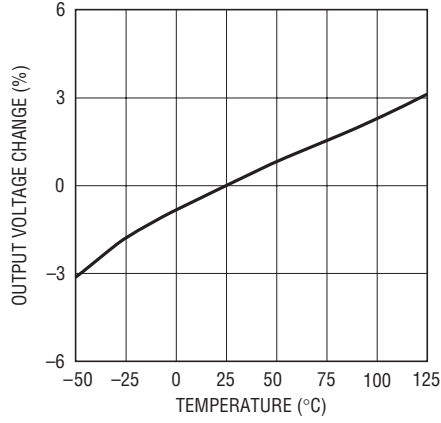

3498 G14

V_{OUT2} Load Regulation

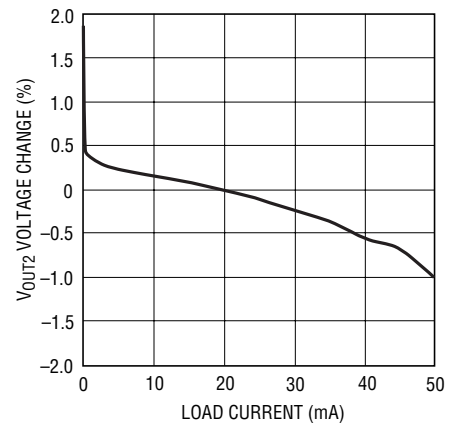

3498 G15

OLED Minimum Switching Frequency

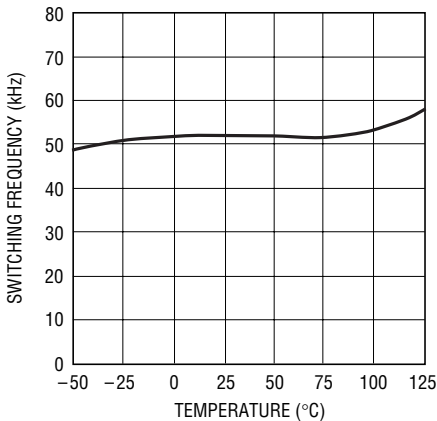

3498 G16

OLED Switching Frequency vs Load Current

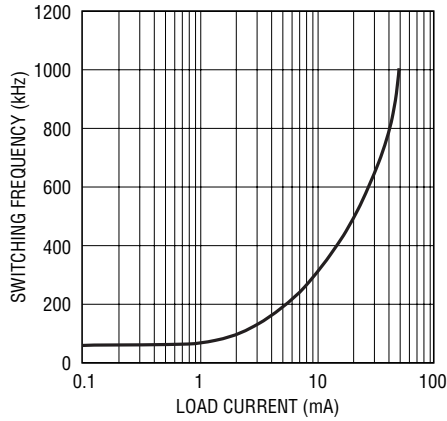

3498 G17

Peak Inductor Current

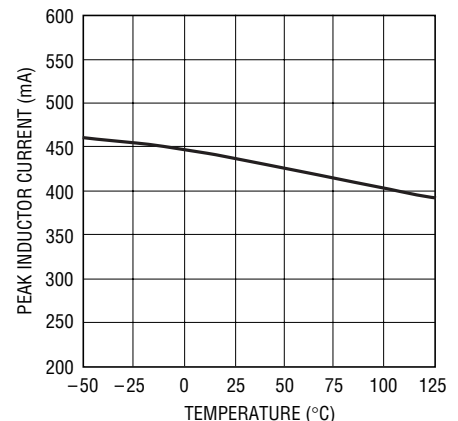

3498 G18

TYPICAL PERFORMANCE CHARACTERISTICS $T_A = 25^\circ\text{C}$, unless otherwise specified.

LED Switching Waveforms

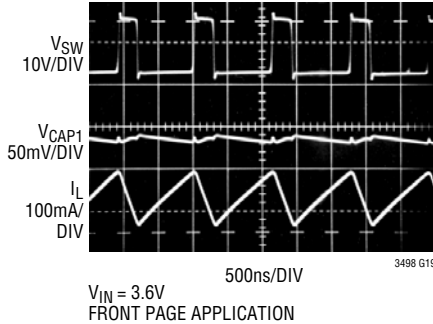

LED Transient Response

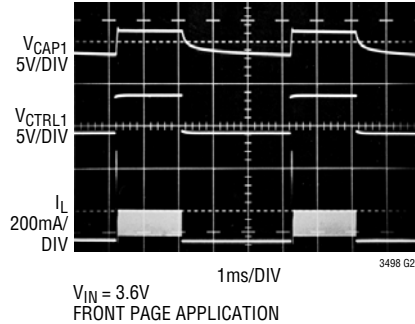

OLED Switching Waveforms with No Load

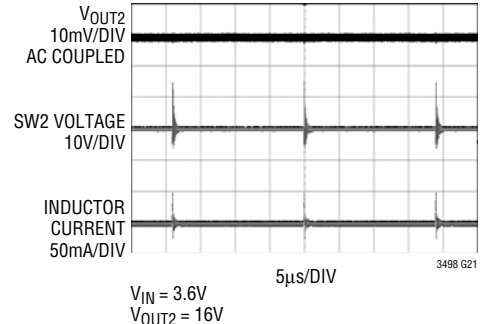

OLED Switching Waveforms with 4mA Load

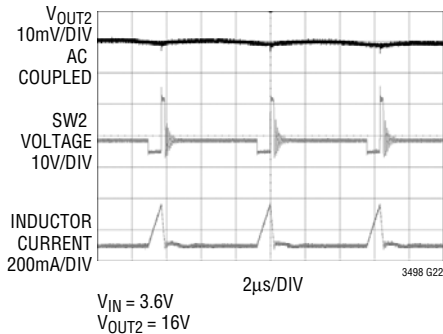

OLED Switching Waveforms with 35mA Load

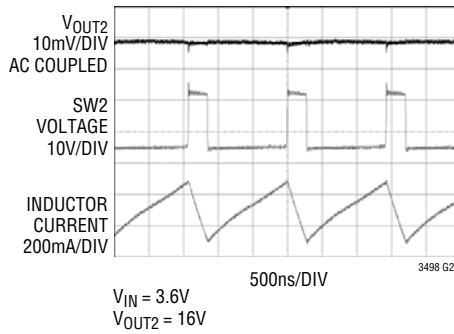

OLED Switching Waveforms During Start-Up

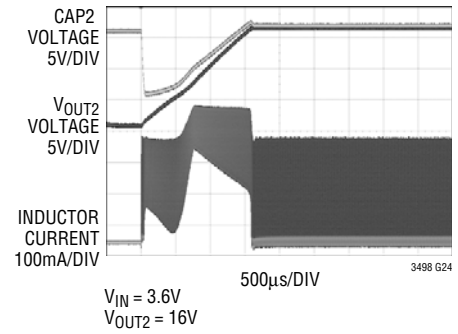

PIN FUNCTIONS

LED1 (Pin 1): Connection Point Between the Anode of the Highest LED and the Sense Resistor. The LED current can be programmed by:

$$I_{LED1} = \frac{200\text{mV}}{R_{SENSE1}}$$

CTRL1 (Pin 2): Dimming and Shutdown Pin. Connect this pin below 75mV to disable the white LED driver. As the pin voltage is ramped from 0V to 1.5V, the LED current ramps from 0 to $(I_{LED1} = 200\text{mV} / R_{SENSE1})$.

GND1, 2 (Pins 3, 4): Ground. Tie directly to local ground plane. GND1 and GND2 are connected internally.

CTRL2 (Pin 5): Dimming and Shutdown Pin. Connect it below 75mV to disable the low noise boost converter. As the pin voltage is ramped from 0V to 1.5V, the output ramps up to the programmed output voltage.

FB2 (Pin 6): Feedback Pin. Reference voltage is 1.215V. There is an internal 182kΩ resistor from FB2 to GND. To achieve desired output voltage, choose R_{FB2} according to the following formula:

$$R_{FB2} = 182 \cdot \left(\frac{V_{OUT2}}{1.215} - 1 \right) \text{ k}\Omega$$

PIN FUNCTIONS

V_{OUT2} (Pin 7): Drain of Output Disconnect PMOS. Place a bypass capacitor from this pin to GND. See the Applications Information section.

CAP2 (Pin 8): Output of the OLED Driver. This pin is connected to the cathode of the internal Schottky diode. Place a bypass capacitor from this pin to GND.

SW2 (Pin 9): Switch Pin. This is the collector of the internal NPN power switch. Minimize the metal trace area connected to this pin to minimize EMI.

V_{IN} (Pin 10): Input Supply Pin. Must be locally bypassed.

SW1 (Pin 11): Switch Pin. Connect the inductor of the white LED driver at this pin. Minimize metal trace area at this pin to minimize EMI.

CAP1 (Pin 12): Output of the White LED Driver. This pin is connected to the cathode of the internal Schottky. Connect the output capacitor to this pin and the sense resistor from this pin to the LED1 pin.

Exposed Pad (Pin 13): Ground. The Exposed Pad must be soldered to the PCB.

BLOCK DIAGRAM

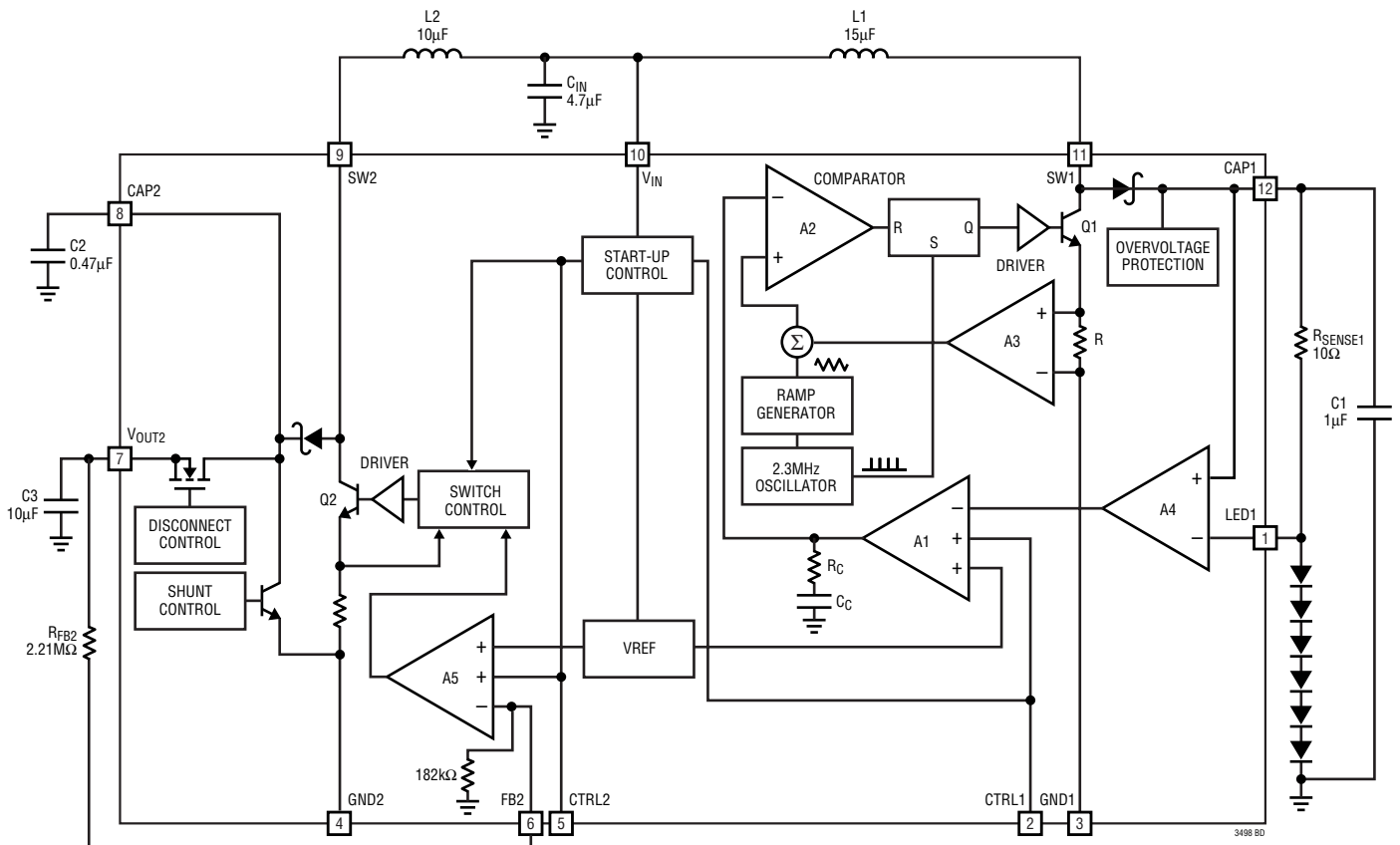

OPERATION—LED DRIVER

The LED portion of the LT3498 uses a constant-frequency, current mode control scheme to provide excellent line and load regulation. Operation can be best understood by referring to the Block Diagram.

At power-up, the capacitor at the CAP1 pin is charged up to V_{IN} (input supply voltage) through the inductor and the internal Schottky diode. If CTRL1 is pulled higher than 125mV, the bandgap reference, the start-up bias and the oscillator are turned on. At the start of each oscillator cycle, the power switch Q1 is turned on. A voltage proportional to the switch current is added to a stabilizing ramp and the resulting sum is fed into the positive terminal of the PWM comparator, A2. When this voltage exceeds the level at the negative input of A2, the PWM logic turns off the power switch. The level at the negative input of A2 is set by the error amplifier A1, and is simply an amplified version of the difference between the V_{CAP1} and V_{LED1} voltage and the bandgap reference. In this manner the error amplifier, A1, sets the correct peak current level in inductor L1 to keep the output in regulation. The CTRL1 pin is used to adjust the LED current. The LED Driver is shutdown when CTRL1 is pulled lower than 75mV.

Minimum Output Current

The LED Driver of the LT3498 can drive a 4-LED string at 2mA LED current, without pulse-skipping, using the same external components shown in the application circuit on the front page of this data sheet. As current is further

reduced, the device will begin skipping pulses. This will result in some low frequency ripple, although the average LED current remains regulated down to zero. The photo in Figure 1 details circuit operation driving four white LEDs at 2mA load. Peak inductor current is less than 60mA and the regulator operates in discontinuous mode, meaning the inductor current reaches zero during the discharge phase. After the inductor current reaches zero, the SW1 pin exhibits ringing due to the LC tank circuit formed by the inductor in combination with the switch and the diode capacitance. This ringing is not harmful; far less spectral energy is contained in the ringing than in the switch transitions.

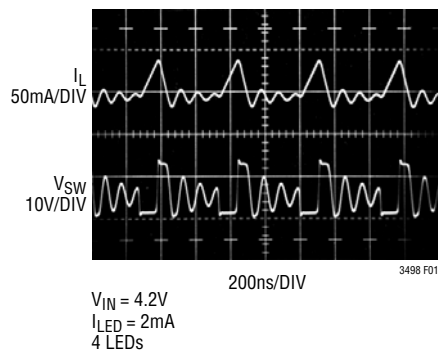

Figure 1. Switching Waveforms with Four White LEDs at 2mA Load

OPERATION—OLED DRIVER

The low noise boost of the LT3498 uses a novel control scheme to provide high efficiency over a wide range of output current. In addition, this technique keeps the switching frequency above the audio band over all load conditions.

The operation of the part can be better understood by referring to the Block Diagram. The part senses the output voltage by monitoring the voltage on the FB2 pin. The user sets the desired output voltage by choosing the value of the external topside feedback resistor. The part incorporates a precision 182kΩ bottom-side feedback resistor. Assuming that output voltage adjustment is not used (CTRL2 pin is tied to 1.5V, or greater), the internal reference ($V_{REF} = 1.215V$) sets the voltage to which FB2 will servo during regulation.

The Switch Control block senses the output of the amplifier and adjusts the switching frequency, as well as other

parameters to achieve regulation. During the start-up of the circuit, special precautions are taken to ensure that the inductor current remains under control.

Because the switching frequency is never allowed to fall below approximately 50kHz, a minimum load must be present to prevent the output voltage from drifting too high. This minimum load is automatically generated within the part via the Shunt Control block. The level of this current is adaptable, removing itself when not needed to improve efficiency at higher load levels.

The low-noise boost of the LT3498 also has an integrated Schottky diode and PMOS output disconnect switch. The PMOS switch is turned on when the part is enabled. When the part is in shutdown, the PMOS switch turns off, allowing the V_{OUT2} node to go to ground. This type of disconnect function is often required in power supplies.

APPLICATIONS INFORMATION—LED DRIVER

Inductor Selection

A 15μH inductor is recommended for most applications for the LED driver of the LT3498. Although small size and high efficiency are major concerns, the inductor should have low core losses at 2.3MHz and low DCR (copper wire resistance). Some small inductors in this category are listed in Table 1. The efficiency comparison of different inductors is shown in Figure 2.

Table 1: Recommended Inductors

PART	L (μH)	MAX DCR (Ω)	CURRENT RATING (mA)	VENDOR
LQH32CN150K53	15	0.58	300	Murata www.murata.com
LQH2MCN150K02	15	1.6	200	
LQH32CN100K53	10	0.3	450	
LQH2MCN100K02	10	1.2	225	
SD3110-150	15	0.764	380	Cooper www.cooperet.com
1001AS-150M (TYPE D312C)	15	0.80	360	Toko www.toko.com
D03314-153ML	15	0.86	680	Coilcraft www.coilcraft.com

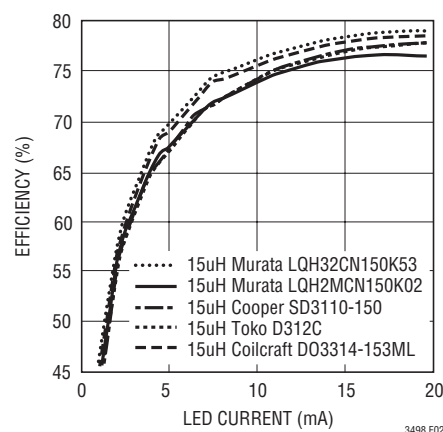

Figure 2. Efficiency Comparison of Different Inductors

Capacitor Selection

The small size of ceramic capacitors makes them ideal for LT3498 LED driver applications. Use only X5R and X7R types, because they retain their capacitance over wider temperature ranges than other types, such as Y5V or Z5U. A 4.7μF input capacitor and a 1μF output capacitor are sufficient for most applications.

APPLICATIONS INFORMATION—LED DRIVER

Table 2: Recommended Ceramic Capacitor Manufacturers

Taiyo Yuden	(800) 368-2496 www.t-yuden.com
AVX	(803) 448-9411 www.avxcorp.com
Murata	(714) 852-2001 www.murata.com

Overvoltage Protection

The LED driver of the LT3498 has an internal open-circuit protection circuit. In the cases of output open circuit, when the LEDs are disconnected from the circuit or the LEDs fail open-circuit, V_{CAP1} is clamped at 27V (typ). The LED driver will then switch at a very low frequency to minimize input current. The V_{CAP1} and input current during output open-circuit are shown in the Typical Performance Characteristics. Figure 3 shows the transient response when the LEDs are disconnected.

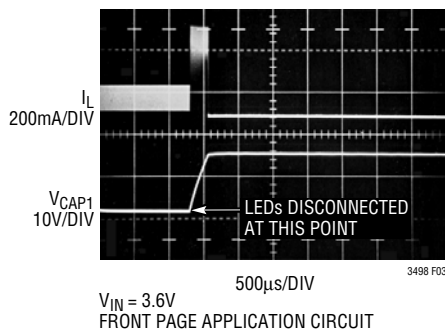

Figure 3. Transient Response with LEDs Disconnected From Output

Inrush Current

The LT3498 LED Driver has a built-in Schottky diode. When supply voltage is applied to the V_{IN} pin, an inrush current flows through the inductor and Schottky diode and charges up the CAP1 voltage. The Schottky diode for the LED Driver of the LT3498 can sustain a maximum current of 1A.

For low DCR inductors, which are usually the case for this application, the peak inrush current can be simplified as follows:

$$\alpha = \frac{r}{2 \cdot L}$$

$$\omega = \sqrt{\frac{1}{L \cdot C} - \frac{r^2}{4 \cdot L^2}}$$

$$I_{PK} = \frac{V_{IN} - 0.6}{L \cdot \omega} \cdot \exp\left(-\frac{\alpha}{\omega} \cdot \frac{\pi}{2}\right)$$

where L is the inductance, r is the DCR of the inductor and C is the output capacitance.

Table 3 gives inrush peak currents for some component selections.

Table 3: Inrush Peak Currents

V_{IN} (V)	r (Ω)	L (μ H)	C_{OUT} (μ F)	I_P (A)
4.2	0.58	15	1	0.828
4.2	1.6	15	1	0.682
4.2	0.8	15	1	0.794
4.2	0.739	15	1	0.803

APPLICATIONS INFORMATION—LED DRIVER

Programming LED Current

The feedback resistor (R_{SENSE1}) and the sense voltage ($V_{CAP1} - V_{LED1}$) control the LED current. The CTRL1 pin controls the sense reference voltage as shown in the Typical Performance Characteristics. For CTRL1 higher than 1.5V, the sense reference is 200mV, which results in full LED current. To have accurate LED current, precision resistors are preferred (1% is recommended). The formula and table for R_{SENSE1} selection are shown below.

$$R_{SENSE1} = \frac{200\text{mV}}{I_{LED}}$$

Table 4: R_{SENSE1} Value Selection for 200mV Sense

I_{LED} (mA)	R_{SENSE1} (Ω)
5	40
10	20
15	13.3
20	10

Dimming Control

There are three different types of dimming control circuits. The LED current can be set by modulating the CTRL1 pin with a DC voltage, a filtered PWM signal or directly with a PWM signal.

Using a DC Voltage

For some applications, the preferred method of brightness control is a variable DC voltage to adjust the LED current. The CTRL1 pin voltage can be modulated to set the dimming of the LED string. As the voltage on the CTRL1 pin increases from 0V to 1.5V, the LED current increases from 0 to I_{LED} . As the CTRL1 pin voltage increases beyond 1.5V, it has no effect on the LED current.

The LED current can be set by:

$$I_{LED} \approx \frac{200\text{mV}}{R_{SENSE1}}, \text{ when } V_{CTRL1} > 1.5\text{V}$$

$$I_{LED} \approx \frac{V_{CTRL1}}{6.25 \cdot R_{SENSE1}}, \text{ when } V_{CTRL1} < 1.25\text{V}$$

Feedback voltage variation versus control voltage is given in the Typical Performance Characteristics.

Using a Filtered PWM Signal

A filtered PWM signal can be used to control the brightness of the LED string. The PWM signal is filtered (Figure 4) by a RC network and fed to the CTRL1 pin.

The corner frequency of R1, C1 should be much lower than the frequency of the PWM signal. R1 needs to be much smaller than the internal impedance of the CTRL1 pin which is 10M Ω (typ).

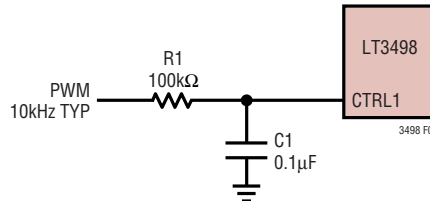

Figure 4. Dimming Control Using a Filtered PWM Signal

APPLICATIONS INFORMATION—LED DRIVER

Direct PWM Dimming

Changing the forward current flowing in the LEDs not only changes the intensity of the LEDs, it also changes the color. The chromaticity of the LEDs changes with the change in forward current. Many applications cannot tolerate any shift in the color of the LEDs. Controlling the intensity of the LEDs with a direct PWM signal allows dimming of the LEDs without changing the color. In addition, direct PWM dimming offers a wider dimming range to the user.

Dimming the LEDs via a PWM signal essentially involves turning the LEDs on and off at the PWM frequency. The typical human eye has a limit of ~60 frames per second. By increasing the PWM frequency to ~80Hz or higher, the eye will interpret that the pulsed light source is continuously on. Additionally, by modulating the duty cycle (amount of “on-time”), the intensity of the LEDs can be controlled. The color of the LEDs remains unchanged in this scheme since the LED current value is either zero or a constant value.

Figure 5 shows a Li-Ion powered driver for four white LEDs. Direct PWM dimming method requires an external NMOS tied between the cathode of the lowest LED in the string and ground as shown in Figure 5. A simple logic level Si2304 MOSFET can be used since its source is connected to ground. The PWM signal is applied to the CTRL1 pin of the LT3498 and the gate of the MOSFET.

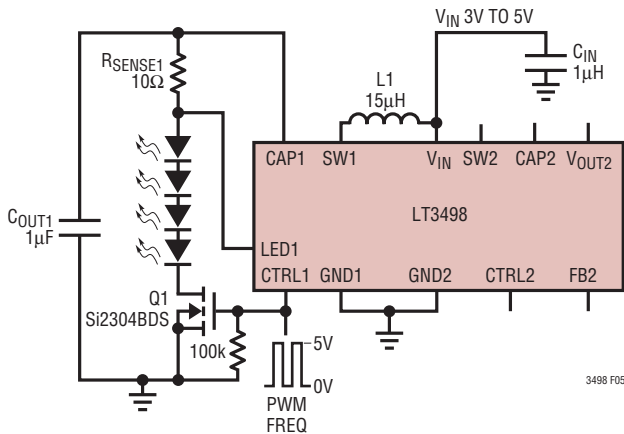

Figure 5. Li-Ion to Four White LEDs with Direct PWM Dimming

The PWM signal should traverse between 0V to 5V, to ensure proper turn-on and -off of the driver and the NMOS transistor Q1. When the PWM signal goes high, the LEDs are connected to ground and a current of $I_{LED} = 200mV / R_{SENSE1}$ flows through the LEDs. When the PWM signal goes low, the LEDs are disconnected and turn off. The MOSFET ensures that the LEDs quickly turn off without discharging the output capacitor which in turn allows the LEDs to turn on faster. Figure 6 shows the PWM dimming waveforms for the circuit in Figure 5.

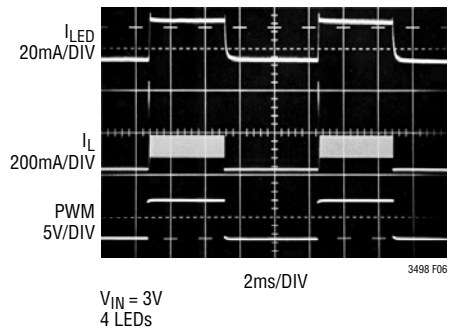

Figure 6. Direct PWM Dimming Waveforms

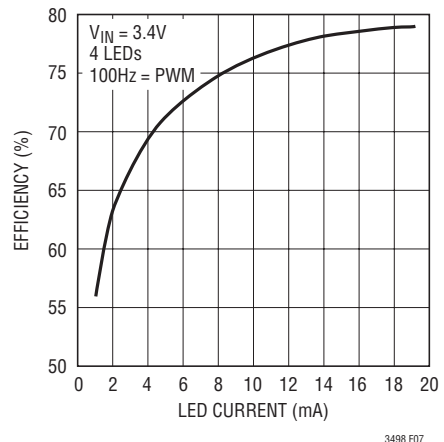

Figure 7. PWM Dimming Efficiency

APPLICATIONS INFORMATION—LED DRIVER

The time it takes for the LED current to reach its programmed value sets the achievable dimming range for a given PWM frequency. For example, the settling time of the LED current in Figure 6 is approximately 40µs for a 3V input voltage. The achievable dimming range for this application and 100Hz PWM frequency can be determined using the following method.

Example:

$$f = 100\text{Hz}, t_{\text{SETTLE}} = 40\mu\text{s}$$

$$t_{\text{PERIOD}} = \frac{1}{f} = \frac{1}{100} = 0.01\text{s}$$

$$\text{Dim Range} = \frac{t_{\text{PERIOD}}}{t_{\text{SETTLE}}} = \frac{0.01\text{s}}{40\mu\text{s}} = 250 : 1$$

Min Duty Cycle =

$$\frac{t_{\text{SETTLE}}}{t_{\text{PERIOD}}} \cdot 100 = \frac{40\mu\text{s}}{0.01\text{s}} \cdot 100 = 0.4\%$$

Duty Cycle Range = 100% → 0.4% at 100Hz

The calculations show that for a 100Hz signal the dimming range is 250:1. In addition, the minimum PWM duty cycle of 0.4% ensures that the LED current has enough time to settle to its final value. Figure 8 shows the dimming range achievable for three different frequencies with a settling time of 40µs.

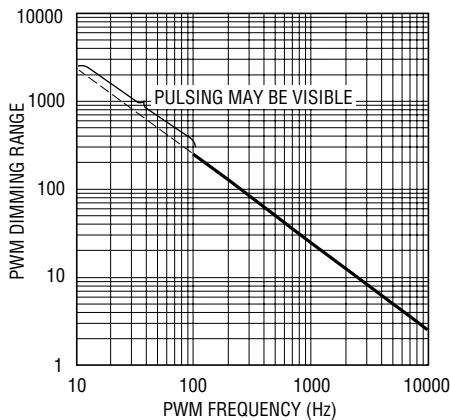

Figure 8. Dimming Ratio vs Frequency

The dimming range can be further extended by changing the amplitude of the PWM signal. The height of the PWM signal sets the commanded sense voltage across the sense resistor through the CTRL1 pin. In this manner both analog dimming and direct PWM dimming extend the dimming range for a given application. The color of the LEDs no longer remains constant because the forward current of the LED changes with the height of the CTRL1 signal. For the four LED application described above, the LEDs can be dimmed first, modulating the duty cycle of the PWM signal. Once the minimum duty cycle is reached, the height of the PWM signal can be decreased below 1.5V down to 125mV. The use of both techniques together allows the average LED current for the four LED application to be varied from 20mA down to less than 20µA. Figure 9 shows the application for dimming using both analog dimming and PWM dimming. A potentiometer must be added to ensure that the gate of the NMOS receives a logic-level signal, while the CTRL1 signal can be adjusted to lower amplitudes.

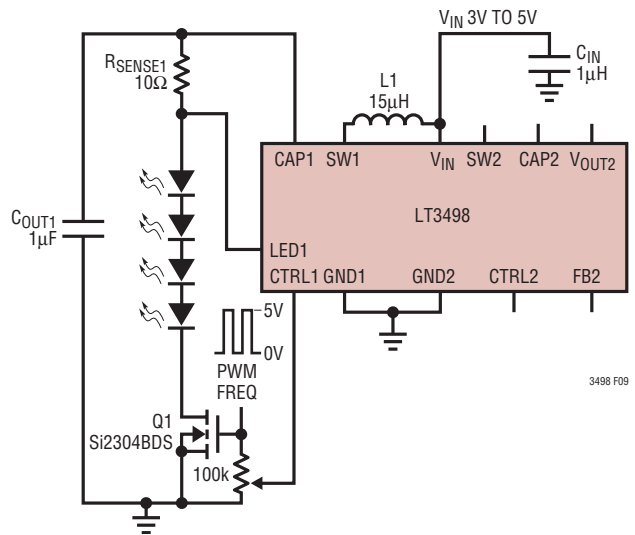

Figure 9. Li-Ion to Four White LEDs with Both PWM Dimming and Analog Dimming

APPLICATIONS INFORMATION—OLED DRIVER

Inductor Selection

Several recommended inductors that work well with the OLED driver of the LT3498 are listed in Table 5, although there are many other manufacturers and devices that can be used. Consult each manufacturer for more detailed information and for their entire selection of related parts. Many different sizes and shapes are available. Use the equations and recommendations in the next few sections to find the correct inductance value for your design.

Table 5: Recommended Inductors

PART	L (μH)	MAX DCR (Ω)	CURRENT RATING (mA)	VENDOR
LQH32CN100K53	10	0.3	450	Murata www.murata.com
LQH2MCN100K02	10	1.2	225	
LQH32CN150K53	15	0.58	300	
LQH2MCN150K02	15	1.6	200	
SD3110-100	10	0.505	470	Cooper www.cooperet.com
SD3110-150	15	0.764	380	

Inductor Selection—Boost Regulator

The formula below calculates the appropriate inductor value to be used for the low noise boost regulator of the LT3498 (or at least provides a good starting point). This value provides a good tradeoff in inductor size and system performance. Pick a standard inductor close to this value. A larger value can be used to slightly increase the available output current, but limit it to around twice the value calculated below, as too large of an inductance will decrease the output voltage ripple without providing much additional output current. A smaller value can be used (especially for systems with output voltages greater than 12V) to give a smaller physical size. Inductance can be calculated as:

$$L = (V_{OUT2} - V_{IN(MIN)} + 0.5V) \cdot 0.66(\mu H)$$

where V_{OUT2} is the desired output voltage and $V_{IN(MIN)}$ is the minimum input voltage. Generally, a 10μH or 15μH inductor is a good choice.

Capacitor Selection

The small size and low ESR of ceramic capacitors makes them suitable for most OLED Driver applications. X5R and X7R types are recommended because they retain their capacitance over wider voltage and temperature ranges than other types such as Y5V or Z5U. A 4.7μF input capacitor and a 10μF output capacitor are sufficient for most applications for the OLED Driver. Always use a capacitor with a sufficient voltage rating. Many capacitors rated at 10μF, particularly 0805 or 0603 case sizes, have greatly reduced capacitance when bias voltages are applied. Be sure to check actual capacitance at the desired output voltage. Generally a 1206 size capacitor will be adequate. A 0.47μF capacitor placed on the CAP node is recommended to filter the inductor current while the larger 10μF placed on the V_{OUT} node will give excellent transient response and stability. Table 6 shows a list of several capacitor manufacturers. Consult the manufacturers for more detailed information and for their entire selection of related parts.

Table 6. Recommended Ceramic Capacitor Manufacturers

MANUFACTURER	PHONE	URL
Taiyo Yuden	408-573-4150	www.t-yuden.com
AVX	843-448-9411	www.avxcorp.com
Murata	814-237-1431	www.murata.com
Kemet	408-986-0424	www.kemet.com

Setting Output Voltage and the Auxiliary Reference Input

The OLED driver of the LT3498 is equipped with both an internal 1.215V reference and an auxiliary reference input. This allows the user to select between using the built-in reference, and supplying an external reference voltage. The voltage at the CTRL2 pin can be adjusted while the chip is operating to alter the output voltage of the LT3498 for purposes such as display dimming or contrast adjustment. To use the internal 1.215V reference, the CTRL2 pin must be held higher than 1.5V. When the CTRL2 pin is held between 0V and 1.5V the OLED driver will regulate the output such that the FB2 pin voltage is nearly equal to the CTRL2 pin voltage. At CTRL2 voltages close to 1.215V,

APPLICATIONS INFORMATION—OLED DRIVER

a soft transition occurs between the CTRL2 pin and the internal reference. Figure 10 shows this behavior.

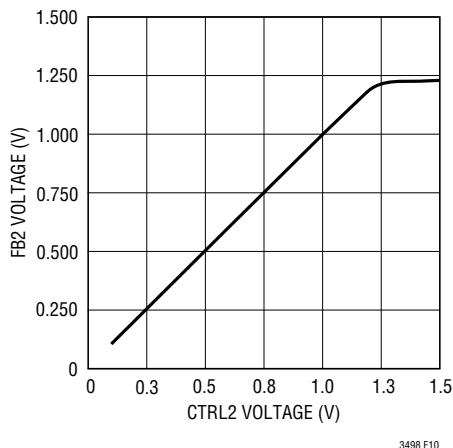

Figure 10. CTRL2 to FB2 Transfer Curve

To set the maximum output voltage, select the values of R_{FB2} according to the following equation:

$$R_{FB2} = 182 \cdot \left(\frac{V_{OUT2}}{1.215} - 1 \right), \text{ k}\Omega$$

When CTRL2 is used to override the internal reference, the output voltage can be lowered from the maximum value down to nearly the input voltage level. If the voltage source driving the CTRL2 pin is located at a distance to the LT3498, a small 0.1µF capacitor may be needed to bypass the pin locally.

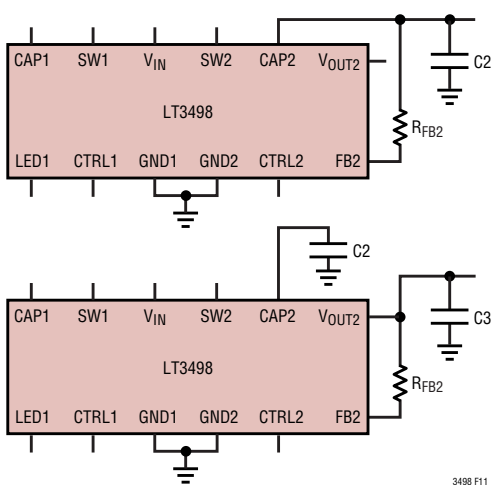

Figure 11. Feedback Connection Using the CAP2 Pin or the V_{OUT2} Pin

Choosing a Feedback Node

The single feedback resistor may be connected to the V_{OUT2} pin or to the CAP2 pin (see Figure 11). Regulating the V_{OUT2} pin eliminates the output offset resulting from the voltage drop across the output disconnect PMOS. Regulating the CAP2 pin does not compensate for the voltage drop across the output disconnect, resulting in an output voltage V_{OUT2} that is slightly lower than the voltage set by the resistor divider. Under most conditions, it is advised that the feedback resistor be tied to the V_{OUT2} pin.

Connecting the Load to the CAP2 Node

The efficiency of the converter can be improved by connecting the load to the CAP2 pin instead of the V_{OUT2} pin. The power loss in the PMOS disconnect circuit is then made negligible. By connecting the feedback resistor to the V_{OUT2} pin, no quiescent current will be consumed in the feedback resistor string during shutdown since the PMOS transistor will be open (see Figure 12). The disadvantage of this method is that the CAP2 node cannot go to ground during shutdown, but will be limited to around a diode drop below V_{IN} . Loads connected to the part should only sink current. **Never force external power supplies onto the CAP2 or V_{OUT2} pins.** The larger value output capacitor should be placed on the node to which the load is connected.

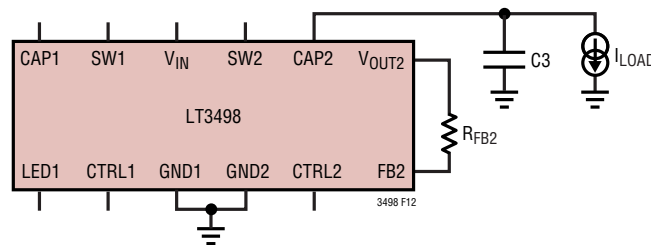

Figure 12. Improved Efficiency

APPLICATIONS INFORMATION—OLED DRIVER

Maximum Output Load Current

The maximum output current of a particular LT3498 circuit is a function of several circuit variables. The following method can be helpful in predicting the maximum load current for a given circuit:

Step 1: Calculate the peak inductor current:

$$I_{PK} = I_{LIMIT} + \frac{V_{IN} \cdot 400 \cdot 10^{-9}}{L} \text{ amps}$$

where I_{LIMIT} is 0.3A for the OLED driver. L is the inductance value in Henrys and V_{IN} is the input voltage to the boost circuit.

Step 2: Calculate the inductor ripple current:

$$I_{RIPPLE} = \frac{(V_{OUT2} + 1 - V_{IN}) \cdot 150 \cdot 10^{-9}}{L} \text{ amps}$$

where V_{OUT2} is the desired output voltage.

If the inductor ripple current is less than the peak current, then the circuit will only operate in discontinuous conduction mode. The inductor value should be increased so that $I_{RIPPLE} < I_{PK}$. An application circuit can be designed to operate only in discontinuous mode, but the output current capability will be reduced.

Step 3: Calculate the average input current:

$$I_{IN(AVG)} = I_{PK} - \frac{I_{RIPPLE}}{2} \text{ amps}$$

Step 4: Calculate the nominal output current:

$$I_{OUT(NOM)} = \frac{I_{IN(AVG)} \cdot V_{IN} \cdot 0.75}{V_{OUT2}} \text{ amps}$$

Step 5: Derate output current:

$$I_{OUT} = I_{OUT(NOM)} \cdot 0.7 \text{ amps}$$

For low output voltages the output current capability will be increased. When using output disconnect (load current taken from V_{OUT2}), these higher currents will cause the drop in the PMOS switch to be higher resulting in reduced output current capability than those predicted by the preceding equations.

Inrush Current

When V_{IN} is stepped from ground to the operating voltage while the output capacitor is discharged, a higher level of inrush current will flow through the inductor and integrated Schottky diode into the output capacitor. Conditions that increase inrush current include a larger more abrupt voltage step at V_{IN} , a larger output capacitor tied to the CAP2 pin, and an inductor with a low saturation current. While the internal diode is designed to handle such events, the inrush current should not be allowed to exceed 1A. For circuits that use output capacitor values within the recommended range and have input voltages of less than 5V, inrush current remains low, posing no hazard to the device. In cases where there are large steps at V_{IN} (more than 5V) and/or a large capacitor is used at the CAP2 pin, inrush current should be measured to ensure safe operation.

APPLICATIONS INFORMATION—LED AND OLED DRIVER

Board Layout Considerations

As with all switching regulators, careful attention must be paid to the PCB board layout and component placement. To prevent electromagnetic interference (EMI) problems, proper layout of high frequency switching paths is essential. Minimize the length and area of all traces connected to the switching node pins (SW1 and SW2). Keep the sense voltage pins (CAP1 and LED1) away from the switching

node. The FB2 connection for the feedback resistor R_{FB2} should be tied directly from the V_{OUT2} pin to the FB2 pin and be kept as short as possible, ensuring a clean, noise-free connection. Place C_{OUT1} and C_{OUT2} next to the CAP1 and CAP2 pins respectively. Always use a ground plane under the switching regulator to minimize interplane coupling. Recommended component placement is shown in Figure 13.

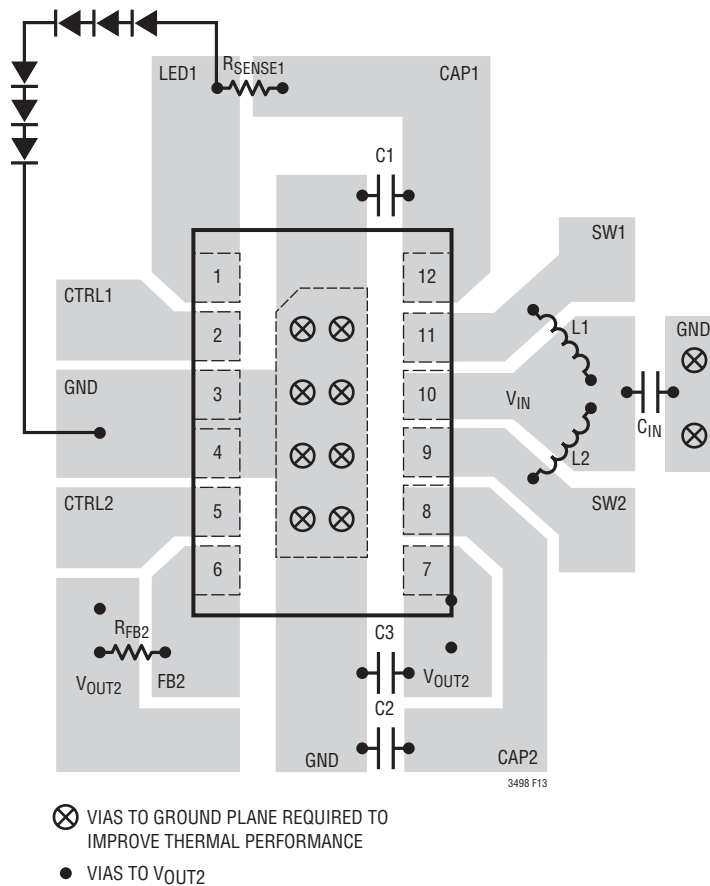
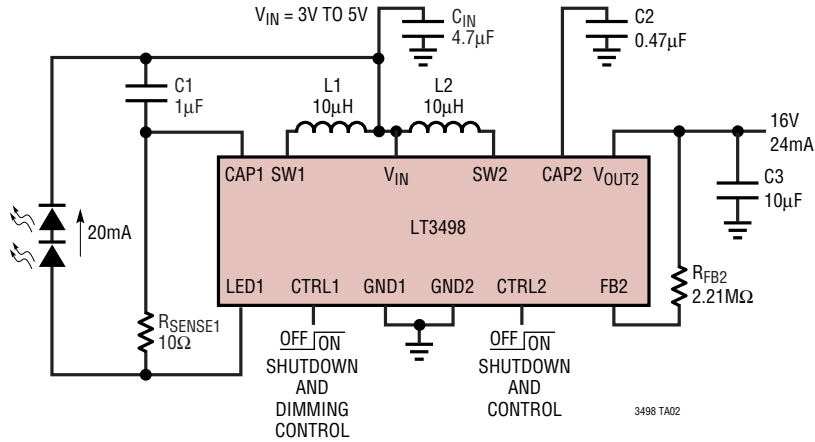

Figure 13. Recommended Board Layout

TYPICAL APPLICATIONS

Li-Ion to Two White LEDs and OLED/LCD Bias



C_{IN}, C₂: X5R OR X7R WITH SUFFICIENT VOLTAGE RATING
 C₁: TAIYO YUDEN GMK212BJ105KG
 C₃: TAIYO YUDEN TMK316BJ106ML
 L₁, L₂: MURATA LQH32CN100K53

LED Efficiency
 V_{IN} = 3.6V, 2 LEDs

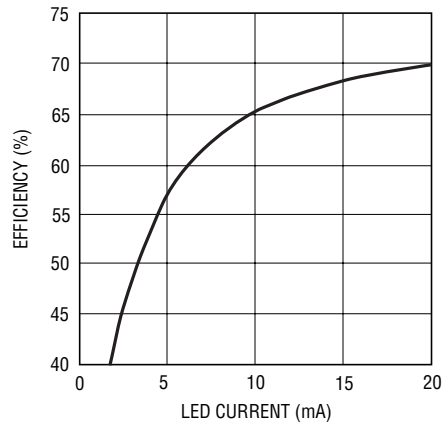

3498 TA02b

TYPICAL APPLICATIONS

Li-Ion to Two White LEDs and OLED/LCD Bias

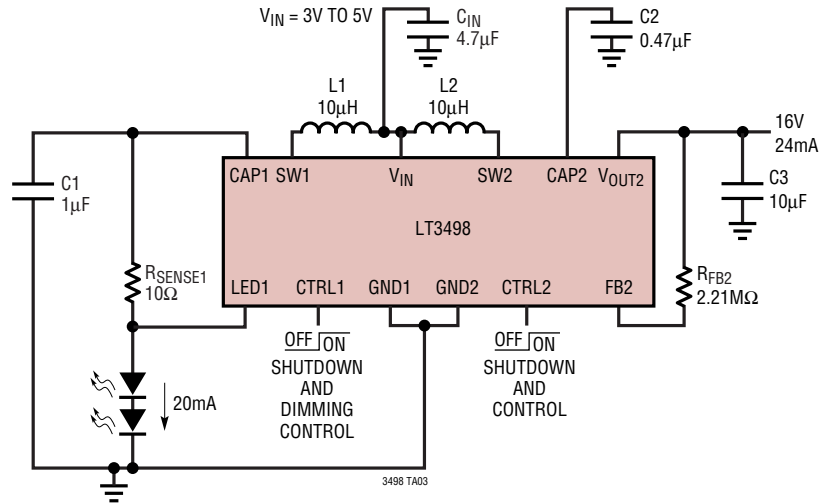

C_{1N}, C₂: X5R OR X7R WITH SUFFICIENT VOLTAGE RATING
 C1: TAIYO YUDEN GMK212BJ105KG
 C3: TAIYO YUDEN TMK316B, J106ML
 L1, L2: MURATA LQH32CN100K53

LED Efficiency
 V_{IN} = 3.6V, 2 LEDs

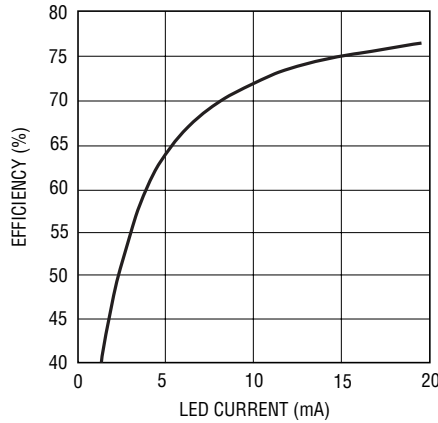

TYPICAL APPLICATIONS

Li-Ion to Three White LEDs and OLED/LCD Bias

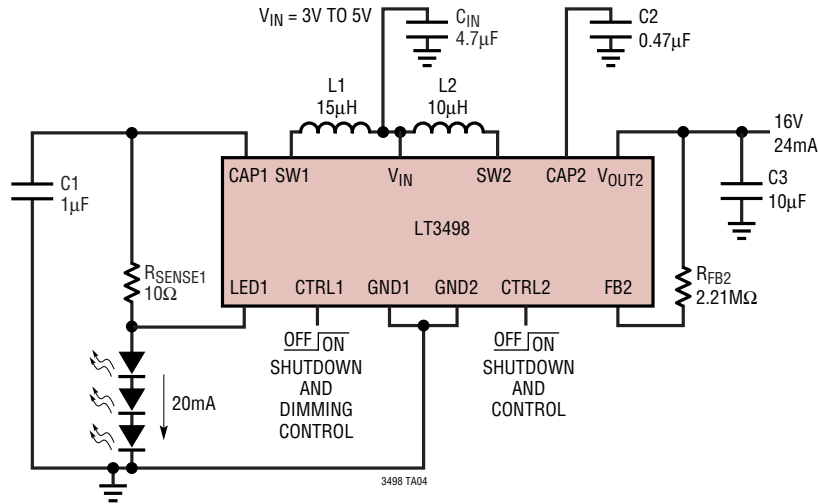

C_{IN} , C_2 : X5R OR X7R WITH SUFFICIENT VOLTAGE RATING
 C_1 : TAIYO YUDEN GMK212BJ105KG
 C_3 : TAIYO YUDEN TMK316BJ106ML
 L_1 : MURATA LQH32CN150K53
 L_2 : MURATA LQH32CN100K53

LED Efficiency
 $V_{IN} = 3.6V$, 3 LEDs

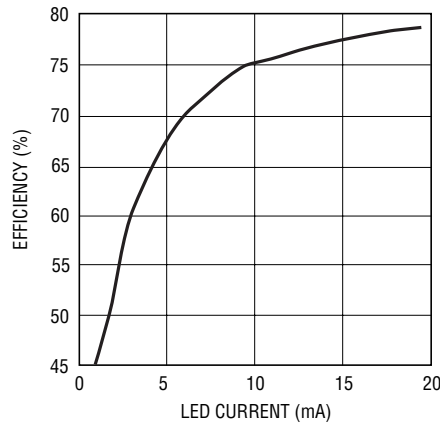

3498 TA04b

TYPICAL APPLICATIONS

Li-Ion to Four White LEDs and OLED/LCD Bias

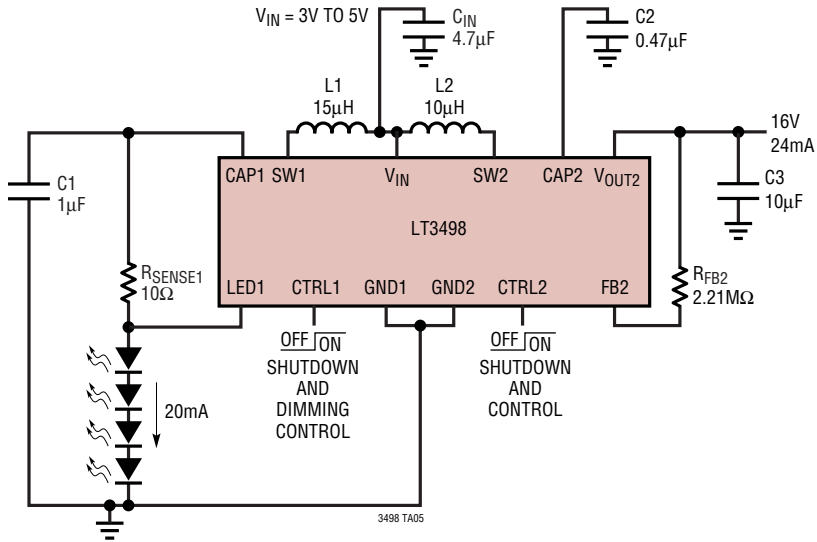

C_{IN}, C₂: X5R OR X7R WITH SUFFICIENT VOLTAGE RATING
 C₁: TAIYO YUDEN GMK212BJ105KG
 C₃: TAIYO YUDEN TMK316BJ106ML
 L₁: MURATA LQH32CN150K53
 L₂: MURATA LQH32CN100K53

LED Efficiency
V_{IN} = 3.6V, 4 LEDs

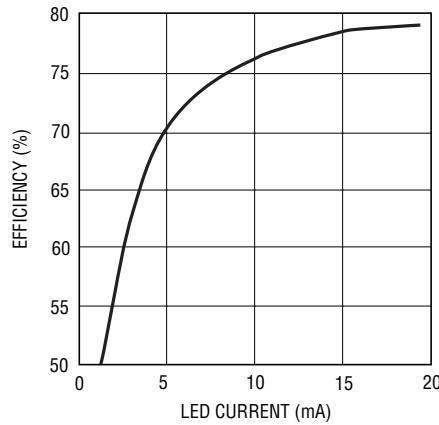

3498 TA05b

TYPICAL APPLICATIONS

Li-Ion to Six White LEDs and OLED/LCD Bias

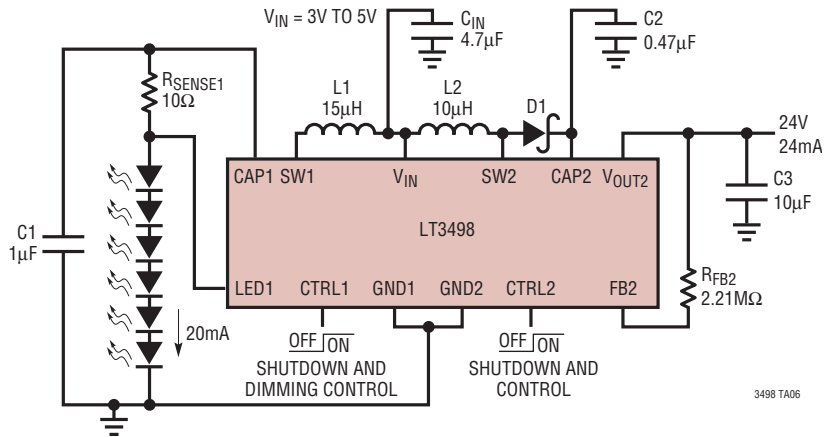

C_{IN} , C_2 : X5R OR X7R WITH SUFFICIENT VOLTAGE RATING
 C_1 : TAIYO YUDEN GMK212BJ105KG
 C_3 : TAIYO YUDEN TMK316BJ106ML
 D_1 : CENTRAL SEMICONDUCTOR CMDSH-3
 L_1 : MURATA LQH32CN150K53
 L_2 : MURATA LQH32CN100K53

**LED Efficiency,
 $V_{IN} = 3.6V$, 6 LEDs**

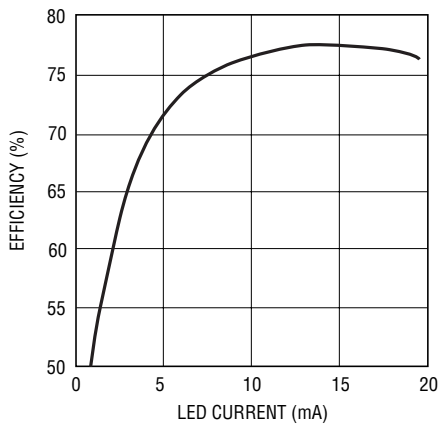

3498 TA06b

**OLED Efficiency and Power Loss
 $V_{IN} = 3.6V$, $V_{OUT2} = 16V$**

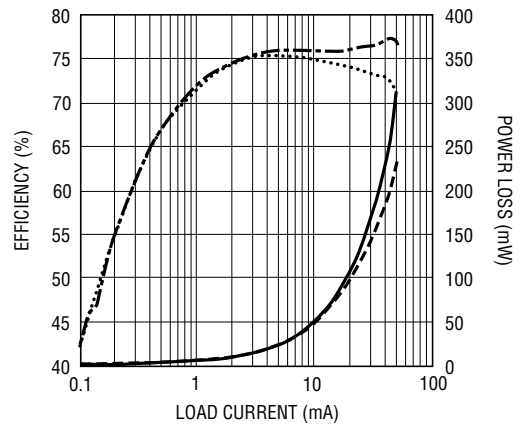

..... LOAD FROM V_{OUT2}
 - - - - - LOAD FROM CAP2
 ——— POWER LOSS FROM V_{OUT2}
 - - - - - POWER LOSS FROM CAP2

3498 TA06c

PACKAGE DESCRIPTION

DDB Package
12-Lead Plastic DFN (3mm × 2mm)
 (Reference LTC DWG # 05-08-1723 Rev 0)

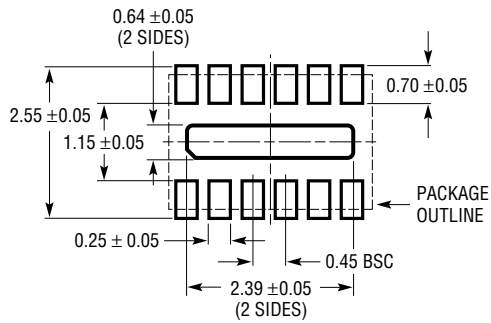

RECOMMENDED SOLDER PAD PITCH AND DIMENSIONS
 APPLY SOLDER MASK TO AREAS THAT ARE NOT SOLDERED

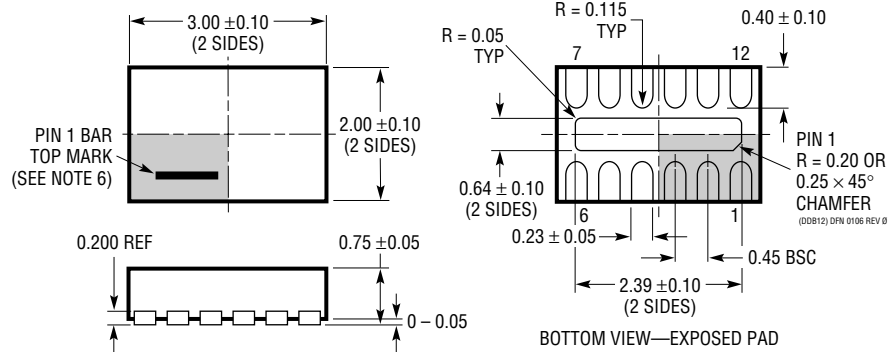

- NOTE:
1. DRAWING IS NOT A JEDEC PACKAGE OUTLINE
 2. DRAWING NOT TO SCALE
 3. ALL DIMENSIONS ARE IN MILLIMETERS
 4. DIMENSIONS OF EXPOSED PAD ON BOTTOM OF PACKAGE DO NOT INCLUDE MOLD FLASH. MOLD FLASH, IF PRESENT, SHALL NOT EXCEED 0.15mm ON ANY SIDE
 5. EXPOSED PAD SHALL BE SOLDER PLATED
 6. SHADED AREA IS ONLY A REFERENCE FOR PIN 1 LOCATION ON THE TOP AND BOTTOM OF PACKAGE

TYPICAL APPLICATION

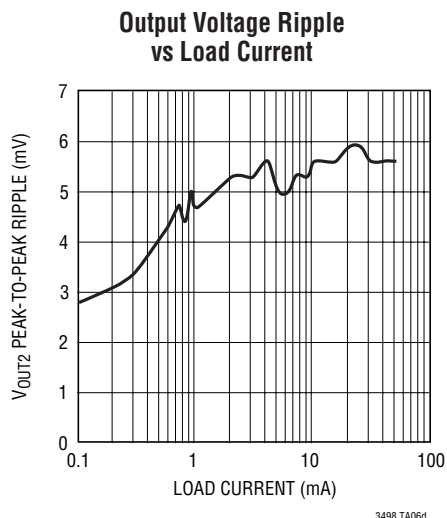

V_{OUT}	R_{FB2} VALUE REQUIRED (M Ω)	MAXIMUM OUTPUT CURRENT AT 3V INPUT (mA)
25	3.57	12.5
24	3.40	13.4
23	3.24	14.4
22	3.09	15.6
21	2.94	16.8
20	2.80	18.1
19	2.67	19.6
18	2.49	21.2
17	2.37	22.5
16	2.21	24.2
15	2.05	26

RELATED PARTS

PART NUMBER	DESCRIPTION	COMMENTS
LT1932	Constant-Current, 1.2MHz, High Efficiency White LED Boost Regulator	V_{IN} : 1V to 10V; $V_{OUT(MAX)}$ = 34V; I_Q = 1.2mA; I_{SD} = <1 μ A; ThinSOT™ Package
LT1937	Constant-Current, 1.2MHz, High Efficiency White LED Boost Regulator	V_{IN} : 2.5V to 10V; $V_{OUT(MAX)}$ = 34V; I_Q = 1.9 μ A; I_{SD} = <1 μ A; ThinSOT and SC70 Packages
LT3463/ LT3463A	Dual Output, Boost/Inverter, 250mA I_{SW} , Constant Off-Time, High Efficiency Step-Up DC/DC Converter with Integrated Schottky Diodes	V_{IN} : 2.3V to 15V; $V_{OUT(MAX)}$ = \pm 40V; I_Q = 40 μ A; I_{SD} = <1 μ A; 3mm \times 3mm DFN-10 Package
LT3465/ LT3465A	Constant-Current, 1.2/2.7MHz, High Efficiency White LED Boost Regulator with Integrated Schottky Diode	V_{IN} : 2.3V to 16V; $V_{OUT(MAX)}$ = 40V; I_Q = 40 μ A; I_{SD} = <1 μ A; 3mm \times 3mm DFN-10 Package
LT3466/ LT3466-1	Dual Constant-Current, 2MHz, High Efficiency White LED Boost Regulator with Integrated Schottky Diode	V_{IN} : 2.3V to 16V; $V_{OUT(MAX)}$ = 40V; I_Q = 65 μ A; I_{SD} = <1 μ A; 3mm \times 2mm DFN-8 Package
LT3471	Dual Output, Boost/Inverter, 1.3A I_{SW} , 1.2MHz, High Efficiency Boost-Inverting DC/DC Converter	V_{IN} : 2.4V to 16V; $V_{OUT(MAX)}$ = \pm 40V; I_Q = 2.5 μ A; I_{SD} = <1 μ A; 3mm \times 3mm DFN-10 Package
LT3473/ LT3473A	40V, 1A, 1.2MHz Micropower Low Noise Boost Converter with Output Disconnect	V_{IN} : 2.2V to 16V; $V_{OUT(MAX)}$ = 36V; I_Q = 150 μ A; I_{SD} = <1 μ A; 3mm \times 3mm DFN-12 Package
LT3491	Constant-Current, 2.3MHz, High Efficiency White LED Boost Regulator with Integrated Schottky Diode	V_{IN} : 2.5V to 12V; $V_{OUT(MAX)}$ = 27V; I_Q = 12.6 μ A; I_{SD} = <8 μ A; 2mm \times 2mm DFN-6 and SC70 Packages
LT3494/ LT3494A	40V, 180mA/350mA Micropower Low Noise Boost Converter with Output Disconnect	V_{IN} : 2.3V to 16V; $V_{OUT(MAX)}$ = 40V; I_Q = 65 μ A; I_{SD} = <1 μ A; 3mm \times 2mm DFN-8 Package
LT3497	Dual 2.3MHz, Full Function LED Driver with Integrated Schottky Diode and 250:1 True Color PWM™ Dimming	V_{IN} : 2.5V to 10V; $V_{OUT(MAX)}$ = 32V; I_Q = 6mA; I_{SD} = <12 μ A; 3mm \times 2mm DFN-10 Package
LT3591	Constant-Current, 1MHz, High Efficiency White LED Boost Regulator with Integrated Schottky Diode and 80:1 True Color PWM Dimming	V_{IN} : 2.5V to 12V; $V_{OUT(MAX)}$ = 40V; I_Q = 4mA; I_{SD} = <9 μ A; 3mm \times 2mm DFN-8 Package

ThinSot and True Color PWM are trademarks of Linear Technology Corporation