

Evaluating the LTC2688 16-Channel, 16-Bit Voltage Output SoftSpan DAC

FEATURES

- ▶ Fully featured evaluation board for the [LTC2688](#) multichannel voltage output DAC
- ▶ Flexible output power supply configuration
- ▶ Easy connection to external loads
- ▶ Test points to monitor DAC status signals
- ▶ [ACE](#) evaluation software compatible

EVALUATION KIT CONTENTS

- ▶ DC2873A-B evaluation board
- ▶ Ribbon cable to connect to the Linduino DC2026C controller board

EQUIPMENT NEEDED

- ▶ DC2026C controller board (must be purchased separately)
- ▶ PC running Windows® 7 or Windows 10
- ▶ Voltmeter
- ▶ Power supply

SOFTWARE NEEDED

- ▶ ACE evaluation software (available for download from the [DC2873A](#) product page)

DOCUMENTS NEEDED

- ▶ LTC2688 data sheet
- ▶ DC2873A-B design files (see the [DC2873A](#) product page)

EVALUATION BOARD PHOTOGRAPH

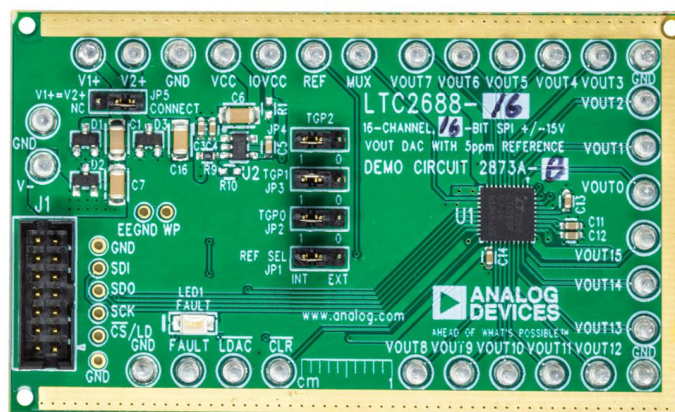

Figure 1. DC2873A-B Evaluation Board

GENERAL DESCRIPTION

The DC2873A-B is a fully featured evaluation board that is used to evaluate the [LTC2688](#), a 16-channel, precision voltage output digital-to-analog converter (DAC).

The DC2873A-B is controlled through a serial peripheral interface (SPI) from the J1 connector. The SPI signals are sent from the [DC2026C](#) controller board through the ribbon cable that is connected to the DC2873A-B.

The DC2873A-B uses [Analysis, Control, Evaluation \(ACE\)](#) software to provide an intuitive graphical user interface (GUI) that configures and controls the LTC2688 using the SPI interface.

The LTC2688 is used for various voltage mode biasing applications such as optical modulators for data communications. The output voltage range for each channel is software selectable, and any channel can be routed to the DC2873A-B MUX pin, allowing either the channel voltage or current to be externally monitored.

For full specifications on the LTC2688, see the LTC2688 data sheet, which must be consulted in conjunction with this user guide when using the DC2873A-B.

TABLE OF CONTENTS

Features.....	1	Multiplexer Output.....	4
Evaluation Kit Contents.....	1	On-Board Connectors.....	4
Equipment Needed.....	1	Getting Started.....	5
Software Needed.....	1	Software Installation Procedures.....	5
Documents Needed.....	1	Evaluation Hardware Setup.....	5
General Description.....	1	Software Operation.....	5
Evaluation Board Photograph.....	1	Main Window.....	6
Evaluation Board Hardware.....	3	Troubleshooting.....	10
Evaluation Board Overview.....	3	Hardware.....	10
Power Supplies.....	3	Evaluation Board Schematic.....	11
Analog Outputs.....	4	Ordering Information.....	12
Digital Interface.....	4	Bill of Materials.....	12
Reference.....	4		

REVISION HISTORY**6/2021—Revision 0: Initial Version**

EVALUATION BOARD HARDWARE

EVALUATION BOARD OVERVIEW

The DC2873A-B requires the power connections and connection to the DC2026C controller board shown in Figure 2. The ribbon cable provided in the evaluation kit connects the DC2873A-B and the DC2026C via the J1 connector. Turrets are provided to connect the DC2873A-B to the power supplies.

The DC2873A-B has other optional features to allow the user to select an external reference, provide separate supply voltages for Channel 0 to Channel 7 and Channel 8 to Channel 15, and to monitor various outputs through the on-board MUX pin. These optional features do not need to be changed for normal operation.

POWER SUPPLIES

The DC2873A-B is powered using external supplies. The minimum requirement to power the DC2873A-B is to provide 5.0 V to 21 V on E1 (V1+) and connect E2 (GND) and E3 (V-) to ground (GND).

As an alternative, the supply connection to E3 (V-) can be in the range between -21 V and ground (GND) to accommodate applications that require a negative supply.

The default position for JP5 (V1+ = V2+) is in the CONNECT position. This position connects the V1+ and V2+ power supplies so that they are at the same voltage. By changing JP5 to the NC (not connected) position, V1+ and V2+ are decoupled on the evaluation board and can be driven with separate supplies. V1+ and V2+ have the same requirement. They must be in the range of 5 V to 21 V but do not need to be the same voltage when decoupled. However, V2+ must be less than or equal to V1+.

E31 (VCC) and E10 (IOVCC) are supplied from on-board regulators by default. If desired, these voltages can be driven with an external supply.

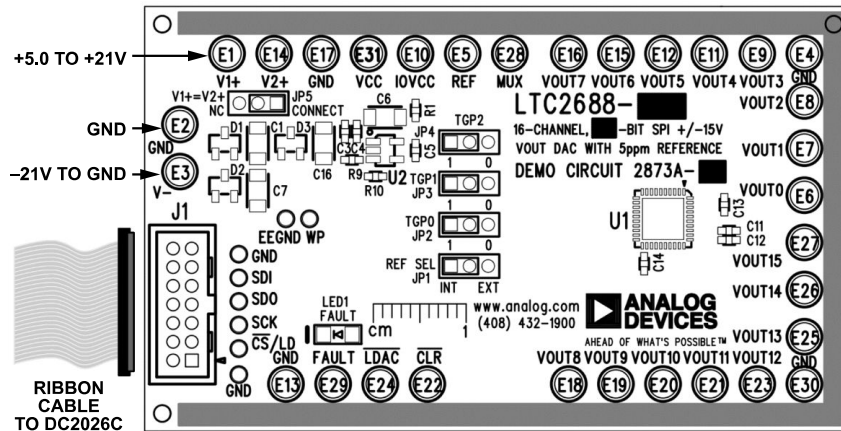

Figure 2. DC2873A-B Hardware Connections

EVALUATION BOARD HARDWARE

ANALOG OUTPUTS

The analog outputs, V_{OUT0} to V_{OUT15} , are available on the E6, E7, E8, E9, E11, E12, E15, E16, E18, E19, E20, E21, E23, E25, E26, and E27 turrets, respectively. Return paths for the ground currents are available on the E4 and E30 (GND) turrets. These turrets must be connected to load GND.

DIGITAL INTERFACE

DC2026C Connections

The DC2873A-B uses the DC2026C to communicate with the ACE evaluation software through the USB port on the DC2026C. Use the provided ribbon cable to connect J1 of the DC2873A-B to J1 of the DC2026C. When this connection is made, the DC2026C powers the electrically erasable programmable read only memory (EEPROM) on the DC2873A-B. The ACE evaluation software uses the EEPROM to identify the DC2873A-B and load the proper plugin.

To ensure proper serial transfers and compatibility, the DC2026C powers the IOV_{CC} pin of the LTC2688, which is nominally 5 V.

DC2026C Connector Pin Descriptions

Figure 3 shows the pins for the DC2026C J1 connector. For descriptions of each pin, see Table 1.

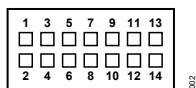

Figure 3. DC2026C J1 Connector Pins

Table 1. DC2026C Connector J1 Pin Descriptions

Pin No.	Mnemonic	Description
1	V+	Unregulated voltage from the DC2026C, nominally 7 V
2	VCCIO	I/O voltage set by JP3 on the DC2026C
3	GND	Ground
4	SCL/SCK	Serial clock from the DC2026C
5	MISO	Serial data from the DC2873A-B
6	CS	Chip select from the DC2026C
7	SDA/MOSI	Serial data from the DC2026C
8	GND	Ground
9	EEDA	Serial data for EEPROM
10	EEV _{CC}	Power supply (V_{CC}) for EEPROM
11	EESCL	Serial clock for EEPROM
12	EEGND	Ground for EEPROM
13	GND	Ground
14	NC	No connection

REFERENCE

By default, the DC2873A-B uses the internal reference of the LTC2688. To use an external reference, place the DC2873A-B JP1

(REF SEL) jumper into the EXT position and apply an external reference to E5 (REF).

MULTIPLEXER OUTPUT

The LTC2688 has an internal multiplexer that allows monitoring of compliance voltages, output currents, and internal die temperature. The output compliance voltages and representative voltages of the output current and internal die temperature are available on the LTC2688 MUX pin and can be routed to the DC2873A-B E28 connector (MUX) using the LTC2688-16 Memory Map view in the ACE GUI (see Figure 8), and setting the appropriate bits in the analog mux control register. Refer to the LTC2688 data sheet for more details on the multiplexer functionality and register structure.

ON-BOARD CONNECTORS

Table 2 describes the on-board connectors on the DC2873A-B.

Table 2. On-Board Connectors

Connector	Function
J1	SPI/I ² C interface pin header connector
JP1	Internal or external reference select
JP2	Toggle Pin 0 (TGP0)
JP3	Toggle Pin 1 (TGP1)
JP4	Toggle Pin 2 (TGP2)
JP5	Connect or disconnect V1+ and V2+
E1	V1+
E2, E4, E13, E17, E30	GND connections
E3	V-
E5	REF
E6	Channel 0 voltage output (VOUT0)
E7	Channel 1 voltage output (VOUT1)
E8	Channel 2 voltage output (VOUT2)
E9	Channel 3 voltage output (VOUT3)
E10	IOV _{CC}
E11	Channel 4 voltage output (VOUT4)
E12	Channel 5 voltage output (VOUT5)
E14	V2+
E15	Channel 6 voltage output (VOUT6)
E16	Channel 7 voltage output (VOUT7)
E18	Channel 8 voltage output (VOUT8)
E19	Channel 9 voltage output (VOUT9)
E20	Channel 10 voltage output (VOUT10)
E21	Channel 11 voltage output (VOUT11)
E22	CLR
E23	Channel 12 voltage output (VOUT12)
E24	LDAC
E25	Channel 13 voltage output (VOUT13)
E26	Channel 14 voltage output (VOUT14)
E27	Channel 15 voltage output (VOUT15)
E28	MUX
E29	FAULT
E31	VCC

GETTING STARTED

The [ACE](#) evaluation software controls and configures the on-board [LTC2688](#) through the [DC2026C](#).

SOFTWARE INSTALLATION PROCEDURES

Before connecting the DC2026C to the DC2873A-B, follow these steps to set up the DC2873A-B for initial use in the ACE evaluation software:

1. Download the ACE evaluation software package from the DC2873A-B product page at www.analog.com/DC2873A to start the ACE evaluation software installation.
2. Open the **ACEInstall_1.21.xxxx.xxxx.exe** file and follow the instructions in the folder to complete the software installation process.

EVALUATION HARDWARE SETUP

When the ACE evaluation software installation is complete, follow these steps to set up the DC2026C and the DC2873A-B together:

1. Connect the DC2026C to the DC2873A-B via the J1 connectors with the ribbon cable provided (see [Figure 2](#)).

2. Connect the desired power supplies to E1 (V1+), E2 (GND), and E3 (V-) on the DC2873A-B.
3. Connect the desired load to the appropriate channel on the DC2873A-B.
4. Connect the load ground to a ground (GND) turrets (either E4 or E30) on the DC2873A-B.
5. Connect the DC2026C to a PC or laptop using the USB cable.
6. Start the ACE evaluation software (see the [Software Operation](#) section).

SOFTWARE OPERATION

To start the ACE evaluation software, from the **Start** menu, click **Analog Devices > ACE**. The software window opens (see [Figure 4](#)) until the software recognizes the DC2873A-B. When the software recognizes the DC2873A-B, the main software window in [Figure 5](#) opens.

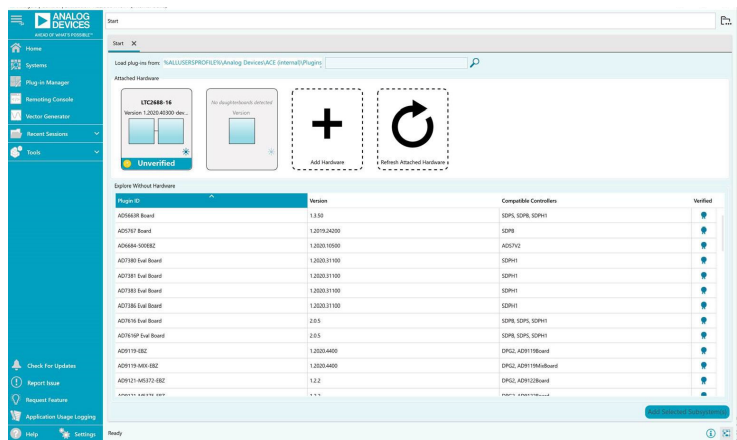

Figure 4. Interface Window

GETTING STARTED

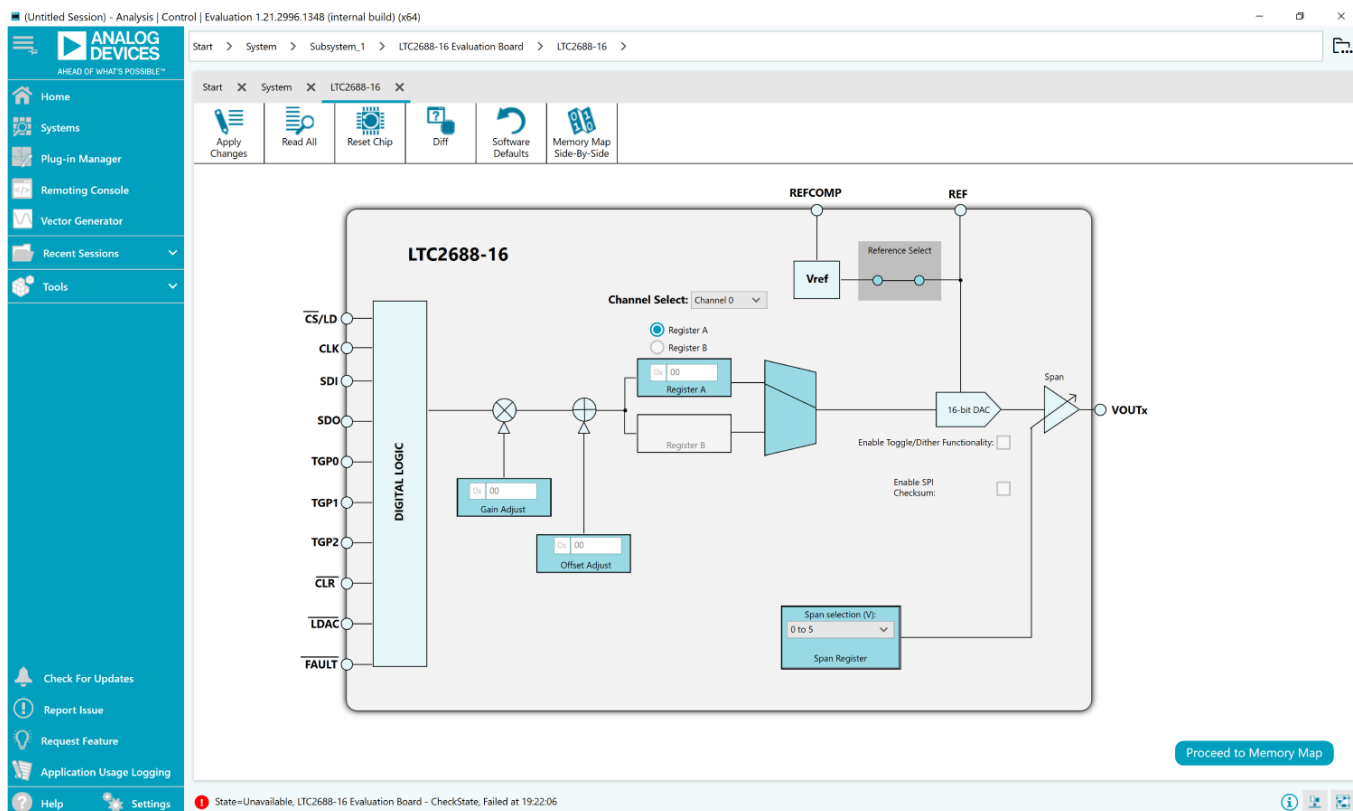

Figure 5. ACE Evaluation Software Main Window

MAIN WINDOW

In the main ACE evaluation software window (see Figure 5), each channel can be controlled. Various settings for the LTC2688 are available in this window, allowing the user to configure the output range, output voltage, gain adjustment, offset adjustment, toggle options, and dither options of each channel.

Refer to the LTC2688 data sheet for more information on the device features associated with the different tab functions that are described in the following sections.

Reference Configuration

The DC2873A-B uses the LTC2688 internal reference to set the full-scale range. To apply an external reference, click the box labeled **Reference Select** (see Figure 5).

Setting the Channel Output Range

To set the output range for a specific channel on the LTC2688,

1. Select the channel from the **Channel Select** dropdown box.
2. Select the desired range for the selected channel using the **Span selection** dropdown box (see Figure 5).

Setting the Channel Voltage Value

To set the output voltage for a specific channel on the LTC2688,

1. Select the channel from the **Channel Select** dropdown box.
2. Type the desired value into the **Register A** text box (see Figure 5).

Toggling Between A and B Output Registers

Each channel has two output registers that can be written independently.

1. Click the **Register A** or **Register B** option to select the register to write to.
2. Type the desired hexadecimal value into the **Register A** (or **Register B**) text box (see Figure 5).

Settling Offset and Gain Values

Each channel can have an offset and gain value applied to the output. The value is applied to each channel independently.

1. Select the channel from the **Channel Select** dropdown box.
2. Type the desired hexadecimal offset or gain adjust value into the **Offset Adjust** or **Gain Adjust** text boxes (see Figure 5).

GETTING STARTED

Enabling Toggle Mode

Toggle mode can be enabled by selecting the **Enable Toggle/Dither Functionality** check box (see [Figure 5](#)). This check box enables the toggle view shown in [Figure 6](#). The toggle signal can then be applied to the selected pin or supplied internally.

Enabling Dither Mode

After enabling the toggle view shown in [Figure 6](#) as described in the [Enabling Toggle Mode](#) section, select the dither mode from the

Mode dropdown box to bring up the dither options (see [Figure 7](#)). The default values for the dither phase (ω_0) and period (N) are 0° and $N = 4$. The phase and period of the dither can be modified using the dropdown boxes to select from a fixed list of options.

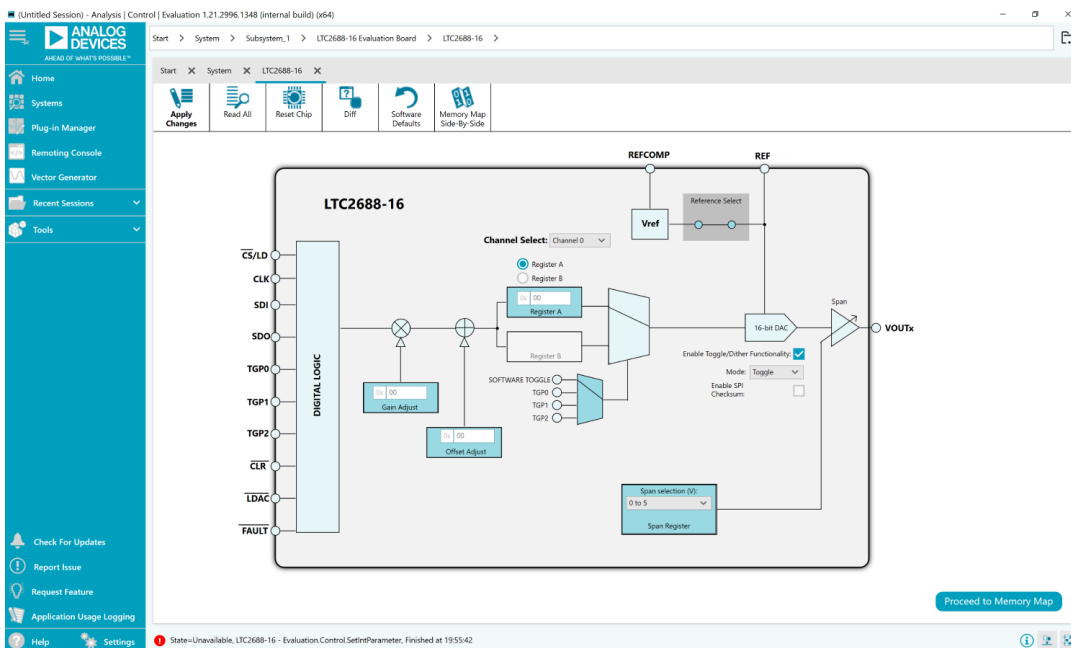

Figure 6. Toggle View

005

GETTING STARTED

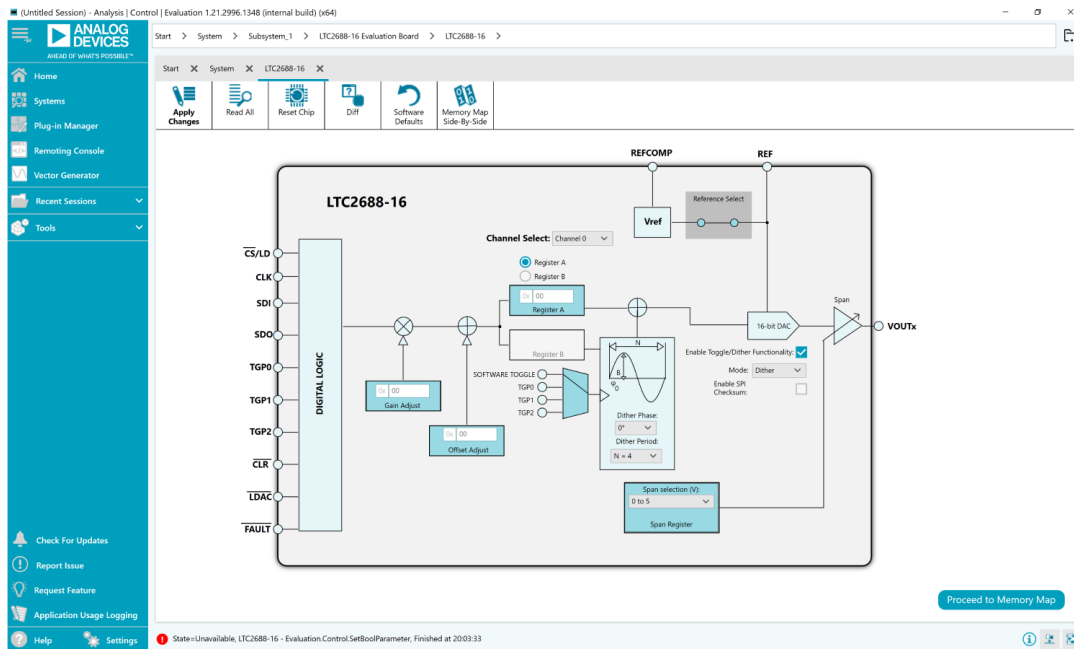

Figure 7. Dither View

GETTING STARTED

Memory Map View

To access the LTC2688-16 Memory Map view, click the **Proceed to Memory Map** button from the software main window (see Figure 5).

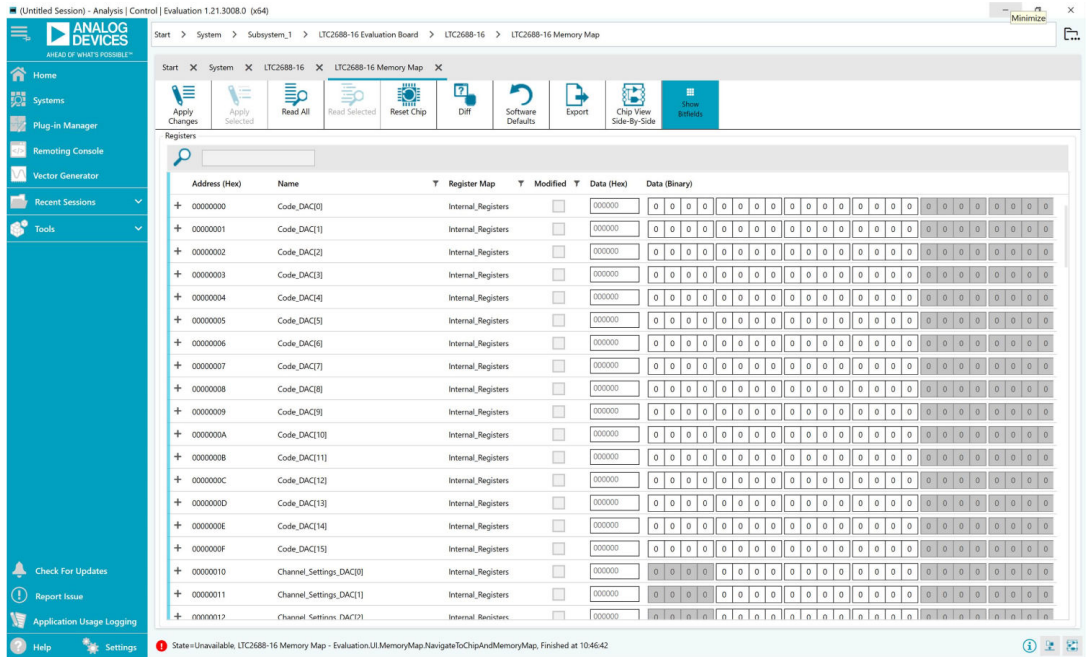

Figure 8. LTC2688-16 Memory Map View

TROUBLESHOOTING**HARDWARE**

A comprehensive list of frequently asked questions (FAQ) is available on the [LTC2688 FAQs](#) page in the [EngineerZone™](#) site. For

other questions, submit them to the [Precision DACs](#) section of the EngineerZone site.

EVALUATION BOARD SCHEMATIC

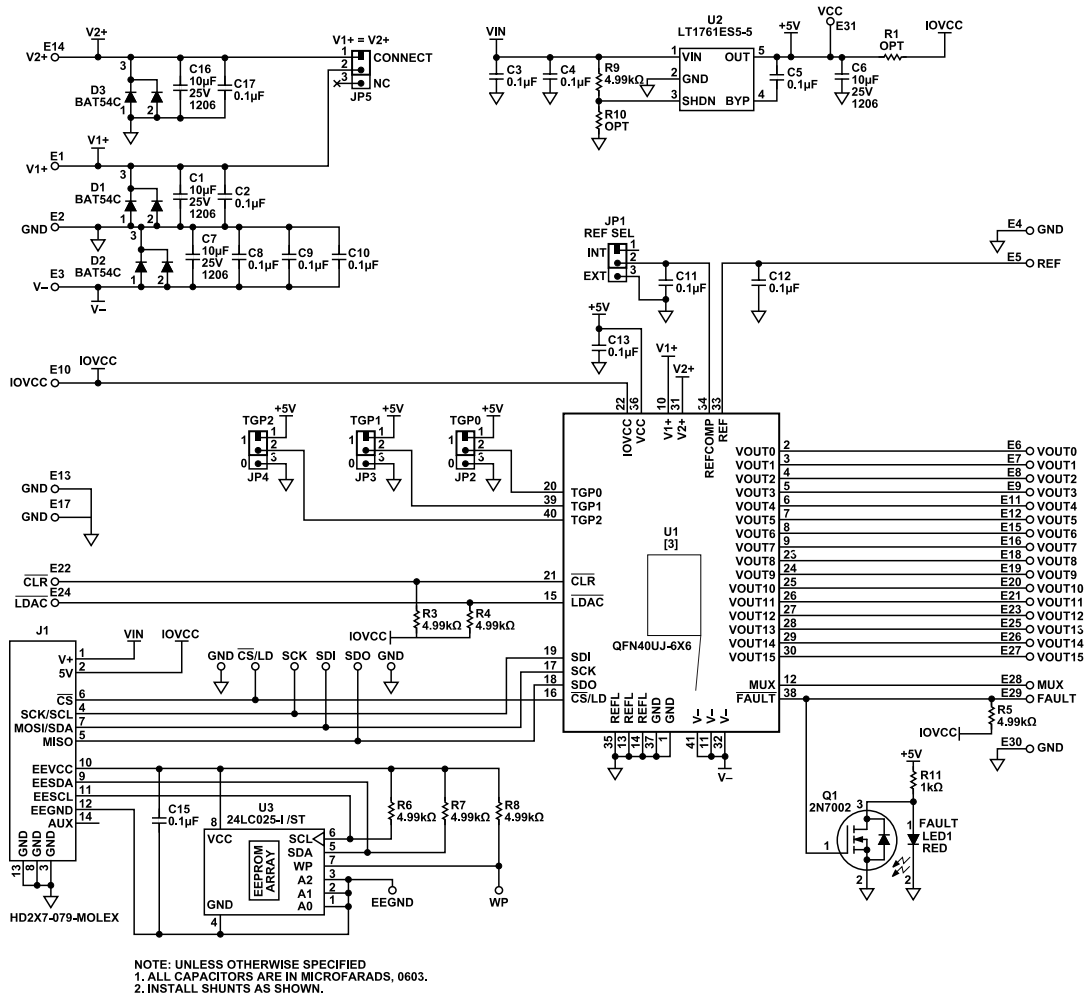

Figure 9. DC2873A-B Schematic

ORDERING INFORMATION

BILL OF MATERIALS

Table 3. DC2873A-B Bill of Materials

Qty	Reference Designator	Description	Manufacturer	Part Number
4	C1, C6, C7, C16	10 μ F, X5R, 25 V, 10%, 1206 capacitors	Murata	GRM31CR71E106KA12L
12	C2 to C4, C8 to C15, C17	0.1 μ F, X7R, 25 V, 10%, 0603 capacitors	Murata	GRM188R71E104KA01D
1	C5	0.01 μ F, X7R, 25 V, 10%, 0603 capacitor	AVX	06033C103KAT2A
3	D1, D2, D3	30 V, 200 mA, SOT-23 Schottky diodes	Diodes, Inc.	BAT54C-7-F
31	E1 to E31	0.064 in. mounting hole turrets	MILL-MAX	2308-2-00-80-00-00-07-0
5	JP1 to JP5	Male, 1 \times 3, 2 mm connector headers	Würth Elektronik	62000311121
1	J1	Male, 2 \times 7, 2 mm connector header	Molex	87831-1420
1	LED1	Red, clear, 3020 (1208) light emitting diode (LED)	ROHM	SML-012V8TT86
1	Q1	N channel, 60 V, 300 mA metal oxide semiconductor field effect transistor (MOSFET)	Vishay	2N7002K-T1-E3
7	R3 to R9	4.99 k Ω , 1%, 1/10 W, 0603 resistors	Vishay	CRCW06034K99FKEA
1	R11	1 k Ω , 1%, 1/10 W, 0603 resistor	Vishay	CRCW06031K00FKEA
1	U2	Low noise, low dropout (LDO) micropower regulator	Analog Devices, Inc.	LT1761ES5-5
1	U3	EEPROM, 2 kb IC	Microchip	24LC025-I/ST
5	JP1 to JP5	Female, 2-position, 2 mm connector shunt	Würth Elektronik	60800213421
1	U1	16-channel, 16-bit, voltage output DAC	Analog Devices	LTC2688CUJ-16#PBF

¹C refers to a communications protocol originally developed by Philips Semiconductors (now NXP Semiconductors).

**ESD Caution**

ESD (electrostatic discharge) sensitive device. Charged devices and circuit boards can discharge without detection. Although this product features patented or proprietary protection circuitry, damage may occur on devices subjected to high energy ESD. Therefore, proper ESD precautions should be taken to avoid performance degradation or loss of functionality.

Legal Terms and Conditions

By using the evaluation board discussed herein (together with any tools, components documentation or support materials, the "Evaluation Board"), you are agreeing to be bound by the terms and conditions set forth below ("Agreement") unless you have purchased the Evaluation Board, in which case the Analog Devices Standard Terms and Conditions of Sale shall govern. Do not use the Evaluation Board until you have read and agreed to the Agreement. Your use of the Evaluation Board shall signify your acceptance of the Agreement. This Agreement is made by and between you ("Customer") and Analog Devices, Inc. ("ADI"), with its principal place of business at One Technology Way, Norwood, MA 02062, USA. Subject to the terms and conditions of the Agreement, ADI hereby grants to Customer a free, limited, personal, temporary, non-exclusive, non-sublicensable, non-transferable license to use the Evaluation Board FOR EVALUATION PURPOSES ONLY. Customer understands and agrees that the Evaluation Board is provided for the sole and exclusive purpose referenced above, and agrees not to use the Evaluation Board for any other purpose. Furthermore, the license granted is expressly made subject to the following additional limitations: Customer shall not (i) rent, lease, display, sell, transfer, assign, sublicense, or distribute the Evaluation Board; and (ii) permit any Third Party to access the Evaluation Board. As used herein, the term "Third Party" includes any entity other than ADI, Customer, their employees, affiliates and in-house consultants. The Evaluation Board is NOT sold to Customer; all rights not expressly granted herein, including ownership of the Evaluation Board, are reserved by ADI. CONFIDENTIALITY. This Agreement and the Evaluation Board shall all be considered the confidential and proprietary information of ADI. Customer may not disclose or transfer any portion of the Evaluation Board to any other party for any reason. Upon discontinuation of use of the Evaluation Board or termination of this Agreement, Customer agrees to promptly return the Evaluation Board to ADI. ADDITIONAL RESTRICTIONS. Customer may not disassemble, decompile or reverse engineer chips on the Evaluation Board. Customer shall inform ADI of any occurred damages or any modifications or alterations it makes to the Evaluation Board, including but not limited to soldering or any other activity that affects the material content of the Evaluation Board. Modifications to the Evaluation Board must comply with applicable law, including but not limited to the RoHS Directive. TERMINATION. ADI may terminate this Agreement at any time upon giving written notice to Customer. Customer agrees to return to ADI the Evaluation Board at that time. LIMITATION OF LIABILITY. THE EVALUATION BOARD PROVIDED HEREUNDER IS PROVIDED "AS IS" AND ADI MAKES NO WARRANTIES OR REPRESENTATIONS OF ANY KIND WITH RESPECT TO IT. ADI SPECIFICALLY DISCLAIMS ANY REPRESENTATIONS, ENDORSEMENTS, GUARANTEES, OR WARRANTIES, EXPRESS OR IMPLIED, RELATED TO THE EVALUATION BOARD INCLUDING, BUT NOT LIMITED TO, THE IMPLIED WARRANTY OF MERCHANTABILITY, TITLE, FITNESS FOR A PARTICULAR PURPOSE OR NON-INFRINGEMENT OF INTELLECTUAL PROPERTY RIGHTS. IN NO EVENT WILL ADI AND ITS LICENSORS BE LIABLE FOR ANY INCIDENTAL, SPECIAL, INDIRECT, OR CONSEQUENTIAL DAMAGES RESULTING FROM CUSTOMER'S POSSESSION OR USE OF THE EVALUATION BOARD, INCLUDING BUT NOT LIMITED TO LOST PROFITS, DELAY COSTS, LABOR COSTS OR LOSS OF GOODWILL. ADI'S TOTAL LIABILITY FROM ANY AND ALL CAUSES SHALL BE LIMITED TO THE AMOUNT OF ONE HUNDRED US DOLLARS (\$100.00). EXPORT. Customer agrees that it will not directly or indirectly export the Evaluation Board to another country, and that it will comply with all applicable United States federal laws and regulations relating to exports. GOVERNING LAW. This Agreement shall be governed by and construed in accordance with the substantive laws of the Commonwealth of Massachusetts (excluding conflict of law rules). Any legal action regarding this Agreement will be heard in the state or federal courts having jurisdiction in Suffolk County, Massachusetts, and Customer hereby submits to the personal jurisdiction and venue of such courts. The United Nations Convention on Contracts for the International Sale of Goods shall not apply to this Agreement and is expressly disclaimed.

