

FEATURES

- 1.2A On-Board Switch
- 100kHz Switching Frequency
- Excellent Dynamic Behavior
- DIP and Surface Mount Packages
- Only 8mA Quiescent Current
- Preset 5V Output Available
- Operates Up to 35V Input
- Micropower Shutdown Mode

APPLICATIONS

- Buck Converter with Output Voltage Range of 2.5V to 30V
- Positive-to-Negative Converter
- Negative Boost Converter
- Multiple Output Buck Converter

DESCRIPTION

The LT1176 is a 1A monolithic bipolar switching regulator which requires only a few external parts for normal opera-

tion. The power switch, all oscillator and control circuitry, and all current limit components are included on the chip. The topology is a classic positive "buck" configuration but several design innovations allows this device to be used as a positive-to-negative converter, a negative boost converter, and as a flyback converter. The switch output is specified to swing below ground.

The LT1176 uses a true analog multiplier in the feedback loop. This makes the device respond nearly instantaneously to input voltage fluctuations and makes loop gain independent of input voltage. As a result, dynamic behavior of the regulator is significantly improved over previous designs.

On-chip pulse by pulse current limiting makes the LT1176 nearly bust-proof for output overloads or shorts. The input voltage range as a buck converter is 8V to 35V, but a self-boot feature allows input voltages as low as 5V in the inverting and boost configurations.

The LT1176 is available in a low cost 8-lead DIP package with frequency preset at 100kHz and current limit at 1.7A. An adjustable output is offered as well as a preset 5V version. For further design details and application help, see the LT1074/LT1076 data sheet and Application Note 44.

TYPICAL APPLICATION

Basic 5V Positive Buck Converter

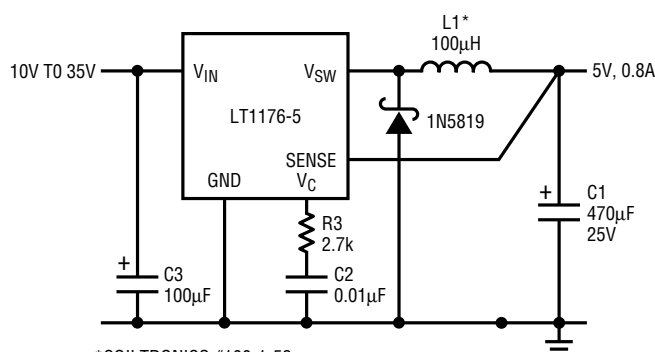

*COILTRONICS #100-1-52

PULSE ENGINEERING, INC. #PE-92102

HURRICANE #HL-AG210LL

THESE ARE LOW COST POWDERED IRON CORES. OPTIMUM EFFICIENCY AND SMALLEST SIZE IS OBTAINED BY USING A LOW LOSS CORE SUCH AS MAGNETICS INC. KOOL M μ . SEE EFFICIENCY GRAPH.

LT1176/76-5 • TA01

5V Buck Converter Efficiency

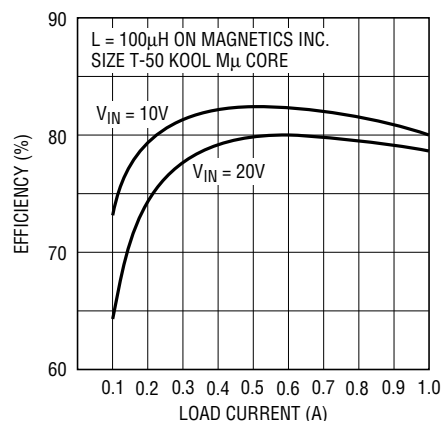

LT1176/76-5 • TA02

ABSOLUTE MAXIMUM RATINGS

Input Voltage	38V
Switch Voltage With Respect to Input Voltage	50V
Switch Voltage With Respect to Ground Pin (V _{SW} Negative) (Note 6)	20V
Feedback Pin Voltage	-2V, 10V
Shutdown Pin Voltage (Not to Exceed V _{IN})	35V
Status Pin Voltage (Current Must Be Limited to 5mA When Status Pin Switches "ON")	30V
I _{LIM} Pin Voltage (Forced)	5.5V
Maximum Operating Ambient Temperature Range LT1176C/LT1176C-5	0°C to 70°C
Maximum Operating Junction Temperature Range LT1176C/LT1176C-5	0°C to 125°C
Storage Temperature Range	-65°C to 150°C
Lead Temperature (Soldering, 10 sec)	300°C

*These thermal resistance numbers are for typical mounting technique. Lower thermal resistance can be obtained with large copper lands, thermal glues or heatsinks.

PACKAGE/ORDER INFORMATION

<p>N8 PACKAGE 8-LEAD PLASTIC DIP T_JMAX = 125°C, θ_{JA} = 90°C/W*</p>	<p>ORDER PART NUMBER</p> <p>LT1176CN8 LT1176CN8-5</p>
<p>S PACKAGE 20-LEAD PLASTIC SOL T_JMAX = 125°C, θ_{JA} = 50°C/W*</p>	<p>ORDER PART NUMBER</p> <p>LT1176CS LT1176CS-5</p>

ELECTRICAL CHARACTERISTICS T_J = 25°C, V_{IN} = 25V, unless otherwise noted

PARAMETER	CONDITIONS	MIN	TYP	MAX	UNITS	
Switch "ON" Voltage (Note 1)	I _{SW} = 0.2A I _{SW} = 1A	●		1.1 1.4	V V	
Switch "OFF" Leakage	V _{IN} = 25V, V _{SW} = 0 V _{IN} = V _{MAX} , V _{SW} = 0 (Note 7)			150 250	μA μA	
Supply Current (Note 2)	V _{FB} = 2.5V, V _{IN} ≤ 35V V _{SHDN} = 0.1V (Device Shutdown) (Note 8)	●	7.5 140.0	10 300	mA μA	
Minimum Supply Voltage	Normal Mode Startup Mode (Note 3)	●	7.3 3.5	8.0 4.8	V V	
Switch Current Limit (Note 4)	I _{LIM} Open R _{LIM} = 10k (Note 5) R _{LIM} = 7k (Note 5)	●	1.2	1.7 1.2 0.8	A A A	
Maximum Duty Cycle		●	85	90	%	
Switching Frequency	V _{FB} = 0V Through 2k (Note 4) (LT1176) V _{SENSE} = 0V (Note 4) (LT1176-5)	●	90 85	100 110 120	kHz kHz kHz kHz	
Switching Frequency Line Regulation	8V ≤ V _{IN} ≤ V _{MAX} (Note 7)	●		0.03	0.1	%/V
Error Amplifier Voltage Gain (Note 9)	1V ≤ V _C ≤ 4V			2000		V/V
Error Amplifier Transconductance (Note 9)			3700	5000	8000	μmho
Error Amplifier Source and Sink Current	Source (V _{FB} = 2V or V _{SENSE} = 4V) Sink (V _{FB} = 2.5V or V _{SENSE} = 5.5V)		100.0 0.7	140.0 1.0	225.0 1.6	μA mA

ELECTRICAL CHARACTERISTICS $T_J = 25^\circ\text{C}$, $V_{IN} = 25\text{V}$, unless otherwise noted

PARAMETER	CONDITIONS		MIN	TYP	MAX	UNITS	
Feedback Pin Bias Current (LT1176)	$V_{FB} = V_{REF}$	●		0.5	2	μA	
Reference Voltage (LT1176)	$V_C = 2\text{V}$	●	2.155	2.21	2.265	V	
Reference Voltage Tolerance (LT1176)	V_{REF} (Nominal) = 2.21V All Conditions of Input Voltage, Output Voltage, Temperature and Load Current	●		± 0.5 ± 1.0	± 1.5 ± 2.5	% %	
Sense Voltage (LT1176-5)	$V_C = 2\text{V}$	●	4.85	5	5.15	V	
Sense Voltage Tolerance (LT1176-5)	V_{OUT} (Nominal) = 5V All Conditions of Input Voltage, Temperature and Load Current	●		± 0.5 ± 1.0	± 2 ± 3	% %	
Sense Pin Divider Resistance (LT1176-5)			3	5	8	k Ω	
Output Voltage Line Regulation	$8\text{V} \leq V_{IN} \leq V_{MAX}$ (Note 7)	●		0.005	0.02	%/V	
V_C Voltage at 0% Duty Cycle	Over Temperature	●		1.5 -4.0		V mV/ $^\circ\text{C}$	
Multiplier Reference Voltage				24		V	
Shutdown Pin Current $V_{SHDN} \leq V_{THRESHOLD}$ ($\cong 2.5\text{V}$)	$V_{SHDN} = 5\text{V}$ ●	●	5	10 50	20 μA	μA	
Shutdown Thresholds	Switch Duty Cycle = 0 Fully Shut Down	● ●		2.2 0.1	2.45 0.30	2.7 0.5	V V
Status Window	As a Percent of Output Voltage			± 4	± 5	± 6	%
Status High Level	$I_{STATUS} = 10\mu\text{A}$ Sourcing	●		3.5	4.5	5.0	V
Status Low Level	$I_{STATUS} = 1.6\text{mA}$ Sinking	●			0.25	0.4	V
Status Delay Time					9	μs	
Status Minimum Width					30	μs	

The ● denotes specifications which apply over the full operating temperature range.

Note 1: To calculate maximum switch “ON” voltage at current between low and high conditions, a linear interpolation may be used.

Note 2: A feedback pin voltage (V_{FB}) of 2.5V forces the V_C pin to its low clamp level and the switch duty cycle to zero. This approximates the zero load condition where duty cycle approaches zero. The LT1176-5 has $V_{SENSE} = 5.5\text{V}$.

Note 3: Total voltage from V_{IN} pin to ground pin must be $\geq 8\text{V}$ after start-up for proper regulation.

Note 4: Switch frequency is internally scaled down when the feedback pin

voltage is less than 1.3V to avoid extremely short switch-on times. During testing, V_{FB} or V_{SENSE} is adjusted to give a minimum switch-on time of 1 μs .

Note 5: $I_{LM} = (R_{LIM} - 1\text{k})/7.65\text{k}$

Note 6: Switch to input voltage limitation must also be observed.

Note 7: $V_{MAX} = 35\text{V}$

Note 8: Does not include switch leakage.

Note 9: Error amplifier voltage gain and transconductance are specified relative to the internal feedback node. To calculate gain and transconductance from the sense pin (Output) to the V_C pin on the LT1176-5, multiply by 0.44.

Application Hints

Although the LT1176 has a peak switch rating of 1.2A and a maximum duty cycle of 85%, it must be used cautiously in applications which require high switch current and high duty cycle simultaneously, to avoid excessive chip temperature. Thermal resistance is 90 $^\circ\text{C}/\text{W}$ for the 8-pin DIP package and 50 $^\circ\text{C}/\text{W}$ for the 20-pin SO. This limits continuous chip power dissipation to the 0.5W to 1W range. These numbers assume typical mounting techniques. Extra or thick copper connected to the leads can reduce thermal resistance. Bonding the package to the board or using a clip style heatsink can also help. The following formulas will give chip power dissipation and peak switch current for the standard buck converter. Note that surges less than 30 seconds do not need to be considered from a thermal standpoint, but for proper regulation, they must not result in peak switch currents exceeding the 1.2A limit.

$$\text{Power} = I_{LOAD} (V_{OUT}/V_{IN}) + V_{IN} [7\text{mA} + 3\text{mA} (V_{OUT}/V_{IN}) + 0.012 (I_{LOAD})]$$

$$I_{PEAK} = I_{LOAD(PEAK)} + [V_{OUT} (V_{IN} - V_{OUT})]/2E^5(V_{IN})(L)$$

$$\text{Example: } V_{IN} = 15\text{V}, V_{OUT} = 5\text{V}, I_{LOAD} = 0.5\text{A Continuous}, 0.8\text{A Peak}, L = 100\mu\text{H}$$

$$\text{Power } (I_{LOAD} = 0.5\text{A}) = 0.38\text{W}$$

$$I_{PEAK} (I_{LOAD} = 0.8\text{A}) = 0.97\text{A}$$

Where component size or height is critical, we suggest using solid tantalum capacitors (singly or in parallel), but be sure to use units rated for switching applications. Coiltronics is a good source for low profile surface mount inductors and AVX makes high quality surface mount tantalum capacitors. For further help, use Application Notes 19 and 44, LTC's SwitcherCAD computer design program, and our knowledgeable application department.

BLOCK DIAGRAM

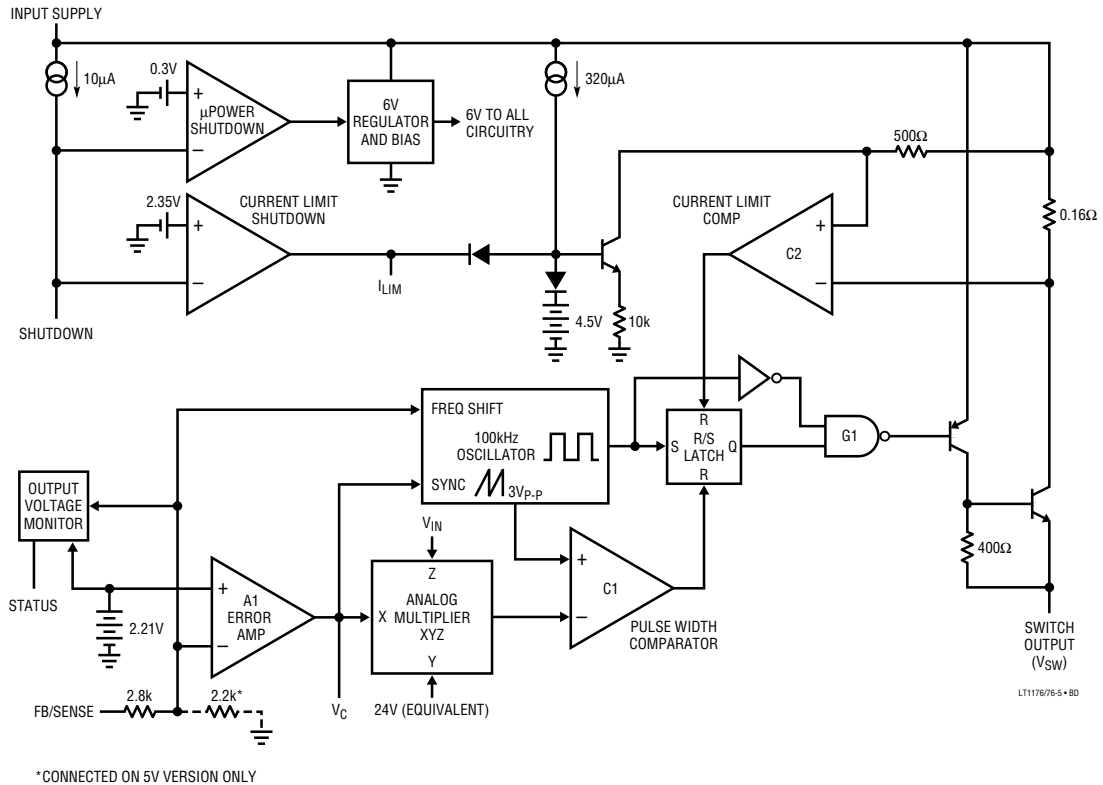

*CONNECTED ON 5V VERSION ONLY

PACKAGE DESCRIPTION Dimensions in inches (millimeters) unless otherwise noted.

N Package 8-Lead Plastic DIP

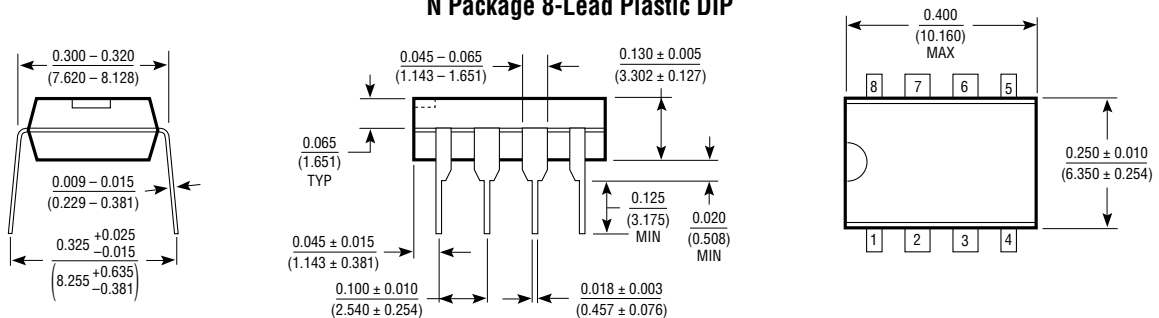

S Package 20-Lead Plastic SOL

