

## FEATURES

- *Guaranteed* low offset voltage
 

LT1002A	60 $\mu$ V max
LT1002	100 $\mu$ V max
- *Guaranteed* offset voltage match
 

LT1002A	40 $\mu$ V max
LT1002	80 $\mu$ V max
- *Guaranteed* low drift
 

LT1002A	0.9 $\mu$ V/ $^{\circ}$ C max
LT1002	1.3 $\mu$ V/ $^{\circ}$ C max
- *Guaranteed* CMRR
 

LT1002A	110dB min
LT1002	110dB min
- *Guaranteed* channel separation
 

LT1002A	132dB min
LT1002	130dB min
- *Guaranteed* matching characteristics
- Low noise 0.35 $\mu$ V p-p

## APPLICATIONS

- Thermocouple Amplifiers
- Strain Gauge Amplifiers
- Low level signal processing
- Medical instrumentation
- Precision dual limit threshold detection
- Instrumentation amplifiers

## DESCRIPTION

The LT<sup>®</sup>1002 dual, matched precision operational amplifiers combine excellent individual amplifier performance with tight matching and temperature tracking between amplifiers.

In the design, processing, and testing of the device, particular attention has been paid to the optimization of the entire distribution of several key parameters and their matching. Consequently, the specifications of even the low cost commercial grade (the LT1002C) have been spectacularly improved compared to presently available devices.

Essentially, the input offset voltage of all units is less than 80 $\mu$ V, and matching between amplifiers is consistently better than 60 $\mu$ V (see distribution plot below). Input bias and offset currents, channel separation, common mode and power supply rejections of the LT1002C are all specified at levels which were previously attainable only on very expensive, selected grades of other dual devices. Power dissipation is nearly halved compared to the most popular precision duals, without adversely affecting noise or speed performance. A by-product of lower dissipation is decreased warm-up drift. For even better performance in a single precision op amp, refer to the LT1001 data sheet. A bridge signal conditioning application is shown below. This circuit illustrates the requirement for both excellent matching and individual amplifier specifications.

 LTC and LT are registered trademarks of Linear Technology Corporation.

**Strain Gauge Signal Conditioner with Bridge Excitation**

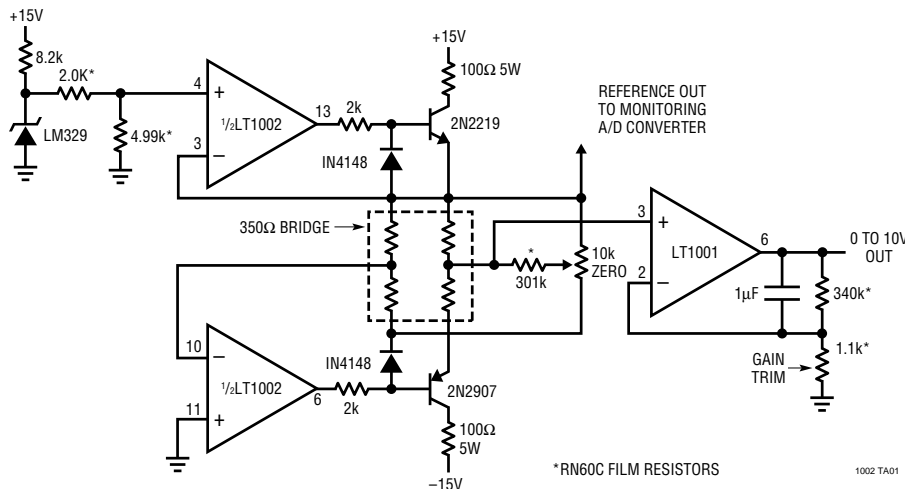

**Distribution of Offset Voltage Match**

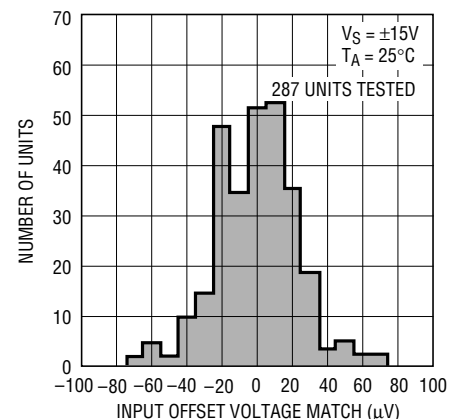

**ABSOLUTE MAXIMUM RATINGS**

Supply Voltage (Note 6) .....	±22V
Differential Input Voltage .....	±30V
Input Voltage Equal to Supply Voltage	
Output Short Circuit Duration .....	Indefinite
Operating Temperature Range	
LT1002AM/LT1002M .....	-55°C to 125°C
LT1002AC/LT1002C .....	0°C to 70°C
Storage Temperature Range	
All Grades .....	-65°C to 150°C
Lead Temperature (Soldering, 10 sec.) .....	300°C

**PACKAGE/ORDER INFORMATION**

<p>J PACKAGE 14 PIN HERMETIC</p> <p>N PACKAGE 14 PIN PLASTIC</p> <p><b>NOTE:</b> Device may be operated even if insertion is reversed; this is due to inherent symmetry of pin locations of amplifiers A and B. (Note 6)</p>	ORDER PART NO.	OFFSET VOLTAGE MAX at 25°C
	LT1002AMJ LT1002MJ LT1002ACJ LT1002CJ LT1002ACN LT1002CN	60µV 100µV 60µV 100µV 60µV 100µV

**ELECTRICAL CHARACTERISTICS, INDIVIDUAL AMPLIFIERS**

V<sub>S</sub> = ±15V, T<sub>A</sub> = 25°C, unless otherwise noted

SYMBOL	PARAMETER	CONDITIONS	LT1002AM/LT1002AC			LT1002M/LT1002C			UNITS
			MIN	TYP	MAX	MIN	TYP	MAX	
V <sub>OS</sub>	Input Offset Voltage	Note 1		20	60		25	100	µV
$\frac{\Delta V_{OS}}{\Delta \text{Time}}$	Long Term Input Offset Voltage Stability	Notes 2 and 3		0.3	1.5		0.4	2.0	µV/month
I <sub>OS</sub>	Input Offset Current			0.3	2.8		0.4	4.2	nA
I <sub>B</sub>	Input Bias Current			±0.6	±3.0		±0.7	±4.5	nA
$\bar{e}_n$	Input Noise Voltage	0.1Hz to 10Hz (Note 2)		0.35	0.7		0.38	0.75	µV <sub>p-p</sub>
e <sub>n</sub>	Input Noise Voltage Density	f <sub>0</sub> = 10Hz (Note 5) f <sub>0</sub> = 1000Hz (Note 2)		10.3 9.6	20.0 11.5		10.5 9.8	20.0 12.0	nV $\sqrt{\text{Hz}}$
A <sub>VOL</sub>	Large Signal Voltage Gain	R <sub>L</sub> ≥ 2kΩ, V <sub>O</sub> = ±12V R <sub>L</sub> ≥ 1kΩ, V <sub>O</sub> = ±10V	400 250	800 500		350 220	800 500		V/mV
CMRR	Common Mode Rejection Ratio	V <sub>CM</sub> = ±13V	110	126		110	126		dB
PSRR	Power Supply Rejection Ratio	V <sub>S</sub> = ±3V to ±18V	108	123		105	123		dB
R <sub>in</sub>	Input Resistance Differential Mode	Note 4	20	100		13	80		MΩ
	Input Voltage Range		±13	±14		±13	±14		V
V <sub>OUT</sub>	Maximum Output Voltage Swing	R <sub>L</sub> ≥ 2kΩ R <sub>L</sub> ≥ 1kΩ	±13 ±12	±14 ±13.5		±13 ±12	±14 ±13.5		V
SR	Slew Rate	R <sub>L</sub> ≥ 2kΩ (Note 4)	0.1	0.25		0.1	0.25		V/µs
GBW	Gain Bandwidth Product	Note 4	0.4	0.8		0.4	0.8		MHz
P <sub>d</sub>	Power Dissipation per amplifier	No load No load, V <sub>S</sub> = ±3V		46 4	75 7		48 4	85 8	mW

## ELECTRICAL CHARACTERISTICS, INDIVIDUAL AMPLIFIERS

$V_S = \pm 15V$ ,  $-55^\circ C \leq T_A \leq 125^\circ C$ , unless otherwise noted

SYMBOL	PARAMETER	CONDITIONS	LT1002AM			LT1002M			UNITS
			MIN	TYP	MAX	MIN	TYP	MAX	
$V_{OS}$	Input Offset Voltage	Note 1	●	30	150	45	230	$\mu V$	
$\frac{\Delta V_{OS}}{\Delta Temp}$	Average Input Offset Voltage Drift		●	0.2	0.9	0.3	1.3	$\mu V/^\circ C$	
$I_{OS}$	Input Offset Current		●	0.8	5.6	1.2	8.5	nA	
$I_B$	Input Bias Current		●	$\pm 1.0$	$\pm 6.0$	$\pm 1.5$	$\pm 9.0$	nA	
$A_{VOL}$	Large Signal Voltage Gain	$R_L \geq 2k\Omega$ , $V_O = \pm 10V$	●	300	700	200	700	V/mV	
CMRR	Common Mode Rejection Ratio	$V_{CM} = \pm 13V$	●	106	122	104	120	dB	
PSRR	Power Supply Rejection Ratio	$V_S = \pm 3V$ to $\pm 18V$	●	102	117	96	117	dB	
	Input Voltage Range		●	$\pm 13$	$\pm 14$	$\pm 13$	$\pm 14$	V	
$V_{OUT}$	Output Voltage Swing	$R_L \geq 2k\Omega$	●	$\pm 12.5$	$\pm 13.5$	$\pm 12.0$	$\pm 13.5$	V	
$P_d$	Power Dissipation per amplifier	No load	●	55	90	60	100	mW	

$V_S = \pm 15V$ ,  $0^\circ C \leq T_A \leq 70^\circ C$ , unless otherwise noted

SYMBOL	PARAMETER	CONDITIONS	LT1002AC			LT1002C			UNITS
			MIN	TYP	MAX	MIN	TYP	MAX	
$V_{OS}$	Input Offset Voltage	Note 1	●	20	100	30	160	$\mu V$	
$\frac{\Delta V_{OS}}{\Delta Temp}$	Average Input Offset Voltage Drift		●	0.2	0.9	0.3	1.3	$\mu V/^\circ C$	
$I_{OS}$	Input Offset Current		●	0.5	4.2	0.6	5.7	nA	
$I_B$	Input Bias Current		●	$\pm 0.7$	$\pm 4.5$	$\pm 1.0$	$\pm 6.0$	nA	
$A_{VOL}$	Large Signal Voltage Gain	$R_L \geq 2k\Omega$ , $V_O = \pm 10V$	●	350	750	250	750	V/mV	
CMRR	Common Mode Rejection Ratio	$V_{CM} = \pm 13V$	●	108	124	106	123	dB	
PSRR	Power Supply Rejection Ratio	$V_S = \pm 3V$ to $\pm 18V$	●	105	120	100	120	dB	
	Input Voltage Range		●	$\pm 13$	$\pm 14$	$\pm 13$	$\pm 14$	V	
$V_{OUT}$	Output Voltage Swing	$R_L \geq 2k\Omega$	●	$\pm 12.5$	$\pm 13.8$	$\pm 12.5$	$\pm 13.8$	V	
$P_d$	Power Dissipation per amplifier	No Load	●	50	85	55	90	mW	

The ● denotes the specifications which apply over the full operating temperature range.

For MIL-STD components, please refer to LTC 883C data sheet for test listing and parameters.

**Note 1:** Offset voltage measured with high speed test equipment, approximately 1second after power is applied.

**Note 2:** This parameter is tested on a sample basis only.

**Note 3:** Long Term Input Offset Voltage Stability refers to the averaged trend line of  $V_{OS}$  versus Time over extended periods after the first 30 days of operation. Excluding the initial hour of operation, changes in  $V_{OS}$  during the first 30 operating days are typically  $2.5\mu V$ .

**Note 4:** Parameter is guaranteed by design.

**Note 5:** 10Hz noise voltage density is sample tested on every lot. Devices 100% tested at 10Hz are available on request.

**Note 6:** The  $V+$  supply terminals are completely independent and may be powered by separate supplies if desired (this approach, however, would sacrifice the advantages of the power supply rejection ratio matching). The  $V-$  supply terminals are both connected to the common substrate and must be tied to the same voltage. Both  $V-$  pins should be used.

**MATCHING CHARACTERISTICS** at  $V_S = \pm 15V$ ,  $T_A = 25^\circ C$ , unless otherwise noted

SYMBOL	PARAMETER	CONDITIONS	LT1002AM/AC			LT1002M/C			UNITS
			MIN	TYP	MAX	MIN	TYP	MAX	
	Input Offset Voltage Match		-	15	40	-	25	80	$\mu V$
$I_B^+$	Average Non-Inverting Bias Current		-	$\pm 0.6$	$\pm 3.5$	-	$\pm 0.7$	$\pm 4.8$	nA
$I_{OS}^+$	Non-Inverting Offset Current		-	0.6	3.5	-	0.7	6.0	nA
$I_{OS}^-$	Inverting Offset Current		-	0.6	3.5	-	0.7	6.0	nA
$\Delta CMRR$	Common Mode Rejection Ratio Match	$V_{CM} = \pm 13V$	110	132	-	108	132	-	dB
$\Delta PSRR$	Power Supply Rejection Ratio Match	$V_S = \pm 3V$ to $\pm 18V$	108	130	-	102	128	-	dB
	Channel Separation	$f \leq 10Hz$ (Note 4)	132	148	-	130	146	-	dB

**MATCHING CHARACTERISTICS** at  $V_S = \pm 15V$ ,  $-55^\circ C \leq T_A \leq 125^\circ C$ , unless otherwise noted

SYMBOL	PARAMETER	CONDITIONS		LT1002AM			LT1002M			UNITS
				MIN	TYP	MAX	MIN	TYP	MAX	
	Input Offset Voltage Match		●	-	50	140	-	60	230	$\mu V$
	Input Offset Voltage Tracking		●	-	0.3	1.0	-	0.4	1.5	$\mu V/^\circ C$
$I_B^+$	Average Non-Inverting Bias Current		●	-	$\pm 1.5$	$\pm 6.0$	-	$\pm 1.8$	$\pm 10.0$	nA
$I_{OS}^+$	Non-Inverting Offset Current		●	-	1.5	6.5	-	1.8	12.0	nA
$I_{OS}^-$	Inverting Offset Current		●	-	1.5	6.5	-	1.8	12.0	nA
$\Delta CMRR$	Common Mode Rejection Ratio Match	$V_{CM} = \pm 13V$	●	106	126		102	124	-	dB
$\Delta PSRR$	Power Supply Rejection Ratio Match	$V_S = \pm 3V$ to $\pm 18V$	●	102	122		94	120	-	dB

**MATCHING CHARACTERISTICS** at  $V_S = \pm 15V$ ,  $0^\circ C \leq T_A \leq 70^\circ C$ , unless otherwise noted

SYMBOL	PARAMETER	CONDITIONS		LT1002AC			LT1002C			UNITS
				MIN	TYP	MAX	MIN	TYP	MAX	
	Input Offset Voltage Match		●	-	30	85	-	45	150	$\mu V$
	Input Offset Voltage Tracking		●	-	0.3	1.0	-	0.4	1.5	$\mu V/^\circ C$
$I_B^+$	Average Non-Inverting Bias Current		●	-	$\pm 1.0$	$\pm 4.5$	-	$\pm 1.2$	$\pm 7.0$	nA
$I_{OS}^+$	Non-Inverting Offset Current		●	-	1.0	5.0	-	1.2	8.5	nA
$I_{OS}^-$	Inverting Offset Current		●	-	1.0	5.0	-	1.2	8.5	nA
$\Delta CMRR$	Common Mode Rejection Ratio Match	$V_{CM} = \pm 13V$	●	108	130	-	105	128	-	dB
$\Delta PSRR$	Power Supply Rejection Ratio Match	$V_S = \pm 3V$ to $\pm 18V$	●	105	126	-	98	124	-	dB

# TYPICAL PERFORMANCE CHARACTERISTICS

**Distribution of Offset Voltage of Individual Amplifiers**

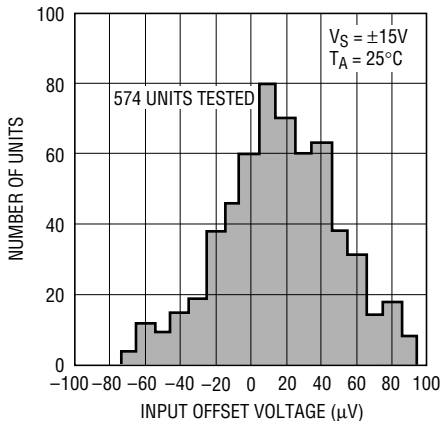

1002 G01

**Distribution of Offset Voltage Drift with Temperature (Individual Amplifiers)**

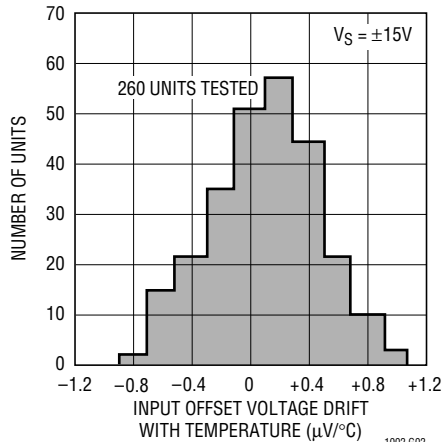

1002 G02

**Distribution of Offset Voltage Match Drift with Temperature**

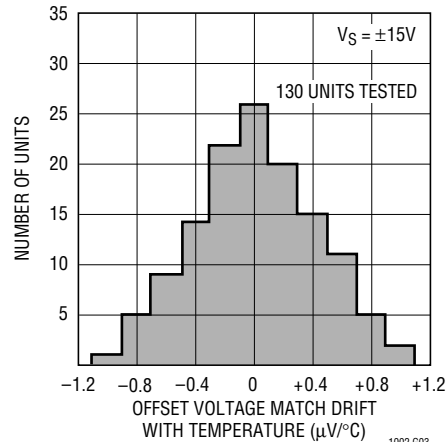

1002 G03

**Offset Voltage Drift with Temperature of Six Representative Units**

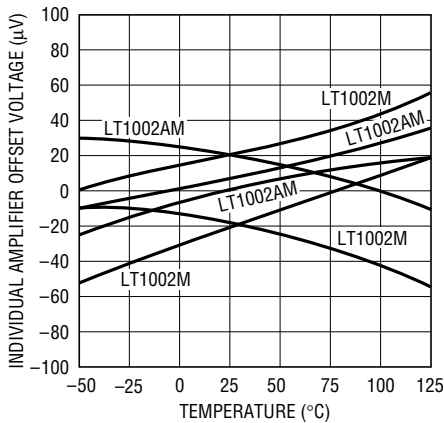

1002 G04

**Offset Voltage Tracking with Temperature of Six Representative Units**

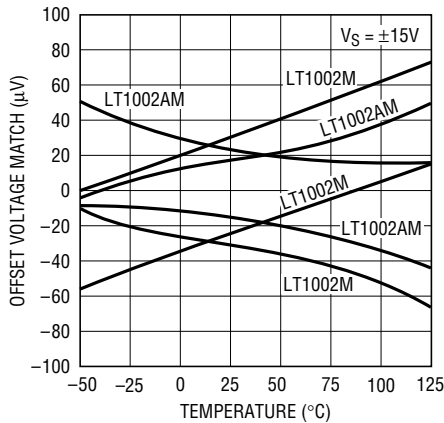

1002 G04

**Warm-Up Drift**

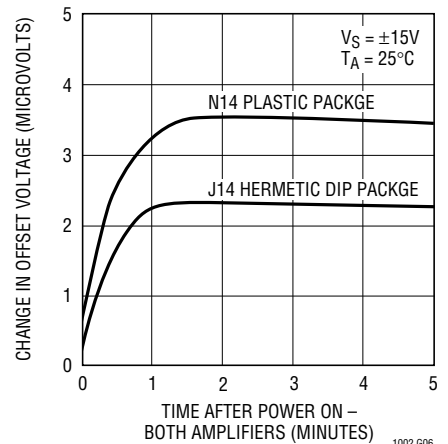

1002 G06

**Long Term Stability of Four Representative Units**

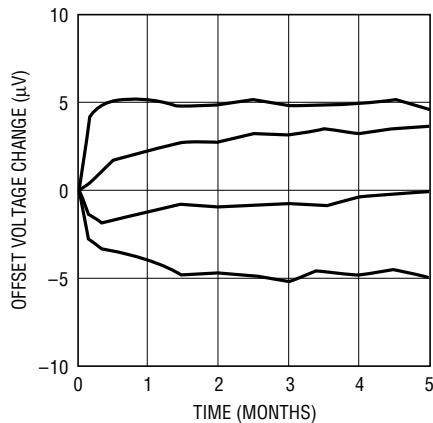

1001 G07

**0.1Hz to 10Hz Noise**

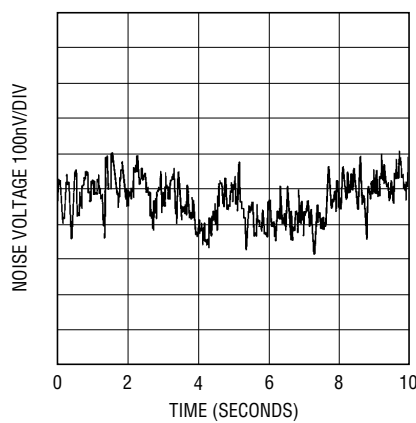

1001 G08

**Noise Spectrum**

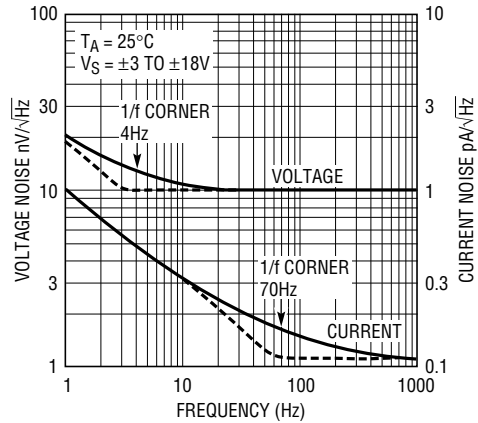

1002 G09

**TYPICAL PERFORMANCE CHARACTERISTICS**

**Matching and Individual Amplifier Bias and Offset Currents vs Temperature**

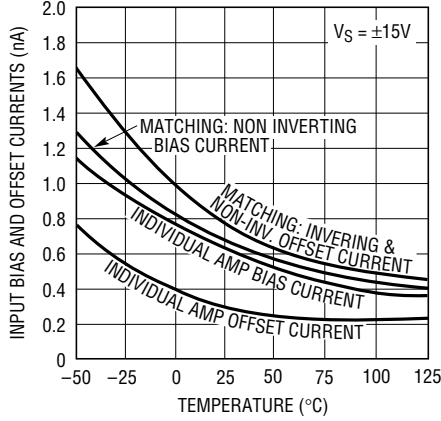

1001 G10

**Input Bias Current Over the Common Mode Range**

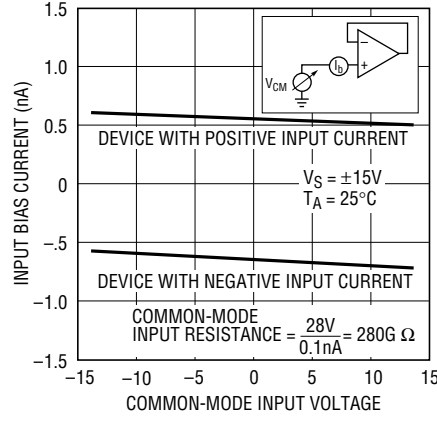

1002 G11

**Input Bias Current vs. Differential Input Voltage**

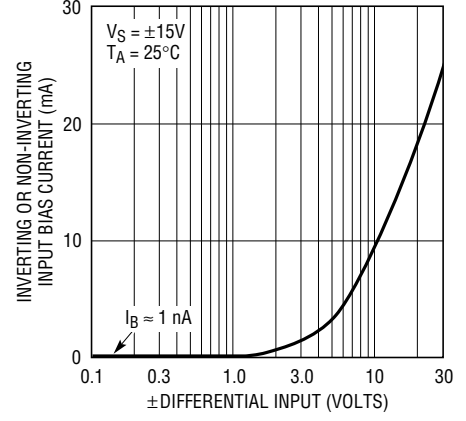

1002 G12

**Open Loop Voltage Gain vs Temperature**

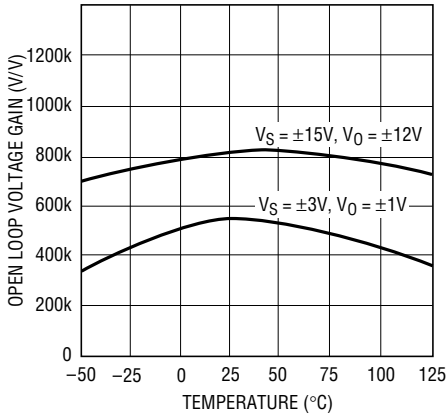

1002 G13

**Open Loop Voltage Gain Frequency Response**

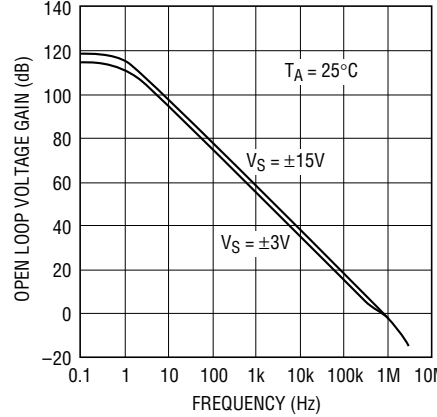

1002 G14

**Gain, Phase Shift vs. Frequency**

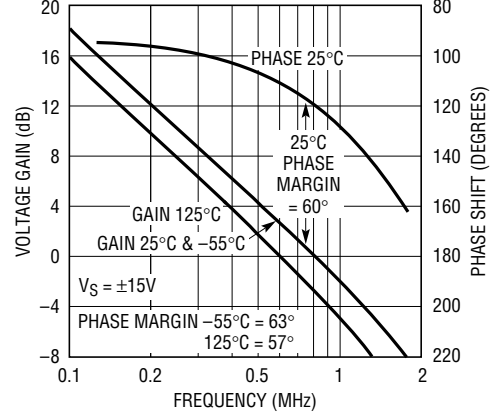

1002 G15

**Open Loop Gain Mismatch vs Frequency**

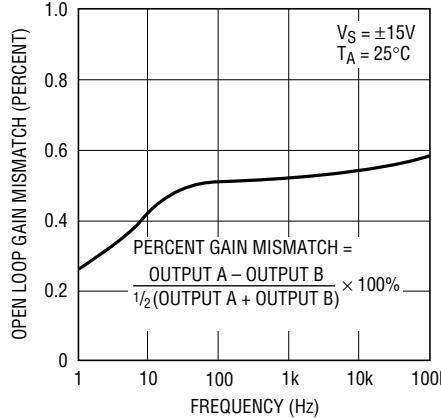

1002 G16

**Closed Loop Output Impedance**

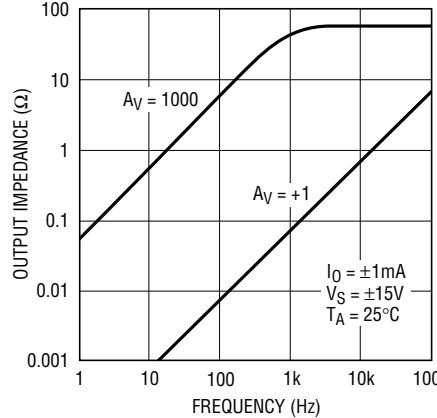

1002 G17

**Power Supply Rejection and PSRR Match vs Frequency**

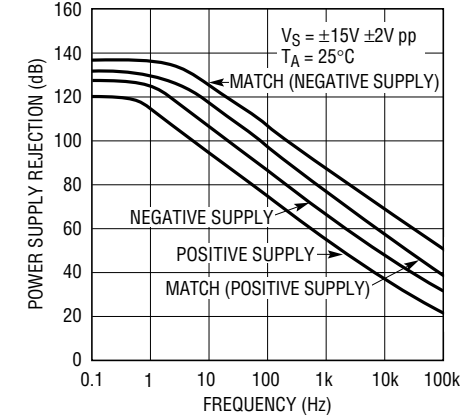

1002 G18

# TYPICAL PERFORMANCE CHARACTERISTICS

**Channel Separation vs Frequency**

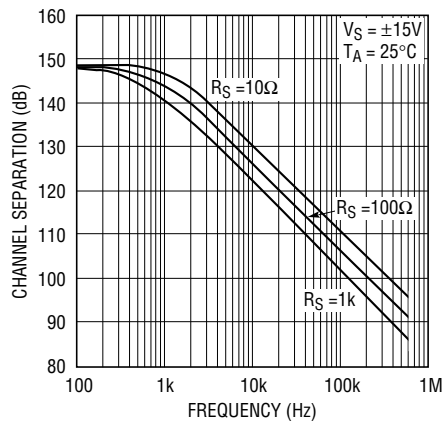

1002 G19

**Common Mode Rejection and CMRR Match vs Frequency**

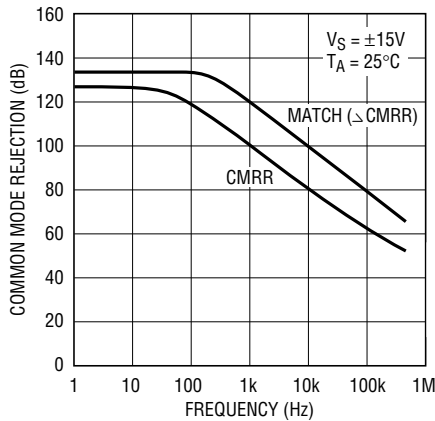

1002 G20

**Common Mode Limit vs Temperature**

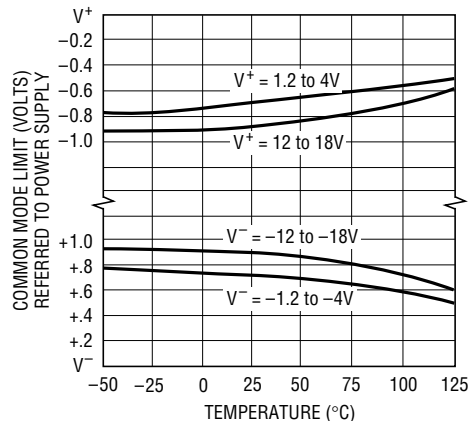

1002 G21

**Supply Current vs. Supply Voltage For Each Amplifier**

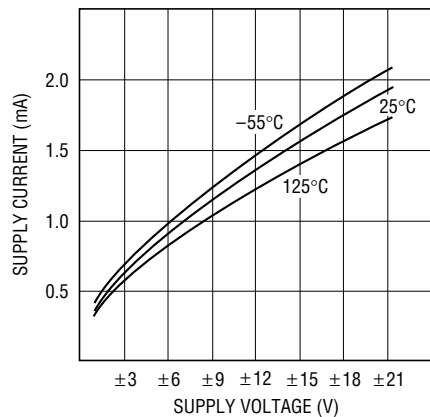

1002 G22

**Large Signal Transient Response**

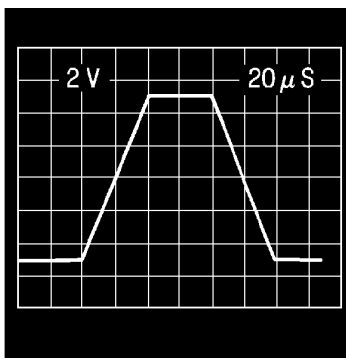

1002 G23

**Maximum Undistorted Output vs. Frequency**

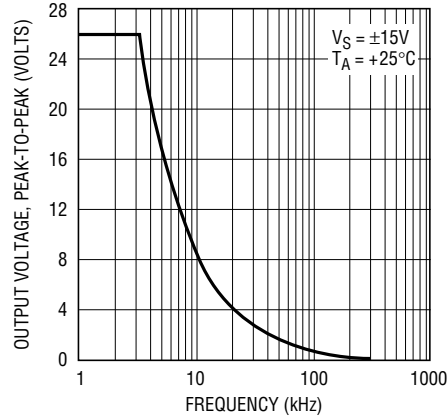

1002 G24

**Small Signal Transient Response**

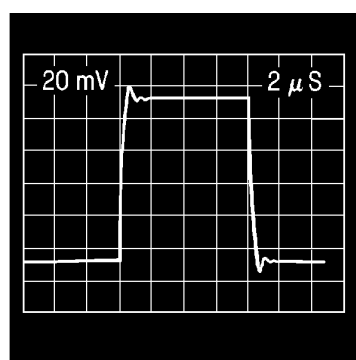

$A_V = +1, C_L = 50\text{pF}$

1002 G25

**Voltage Follower Overshoot vs Capacitive Load**

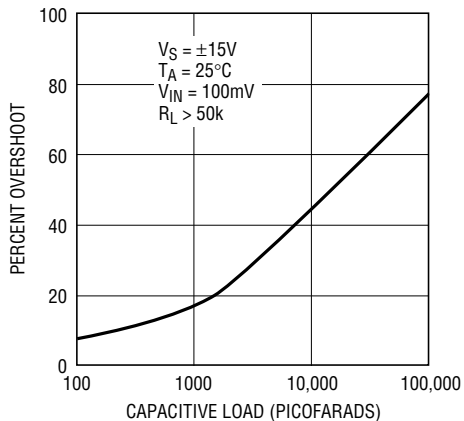

1002 G26

**Small Signal Transient Response**

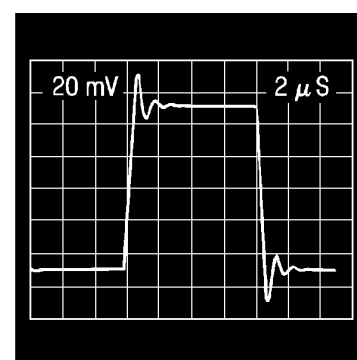

$A_V = +1, C_L = 1000\text{pF}$

1002 G27

## TYPICAL PERFORMANCE CHARACTERISTICS

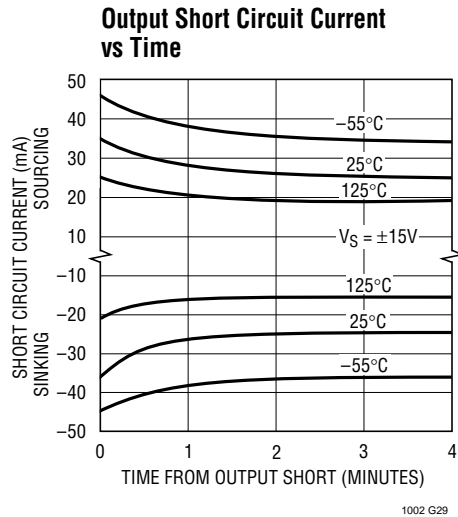
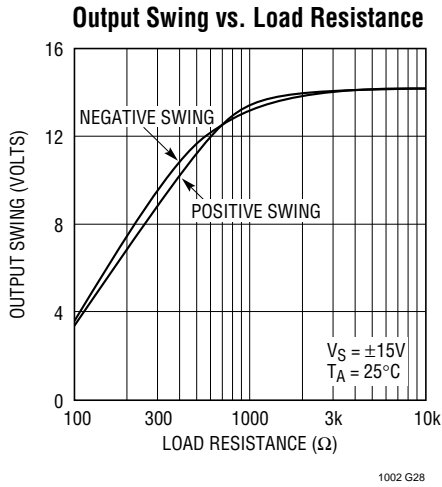

## APPLICATIONS INFORMATION

The LT1002 dual amplifier may be inserted directly into OP-10, OP207, OP227 sockets with or without removal of external nulling potentiometers.

**Offset Voltage Adjustment** The input offset voltage of the LT1002, and its drift with temperature, are permanently trimmed at wafer testing to a low level. However, if further adjustment of  $V_{OS}$  is necessary, nulling with a 10k or 20k potentiometer will not degrade drift with temperature. Trimming to a value other than zero creates a drift of  $(V_{OS}/300)\mu V/^\circ C$ , e.g. if  $V_{OS}$  is adjusted to  $300\mu V$ , the change in drift will be  $1\mu V/^\circ C$ . The adjustment range with a 10k or 20k pot is approximately  $\pm 2.5mV$ . If less adjustment range is needed, the sensitivity and resolution of the nulling can be improved by using a smaller pot in conjunction with fixed resistors. The example has an approximate null range of  $\pm 100\mu V$ .

In matching applications, both amplifiers can be trimmed to zero, or the offset of one amplifier can be trimmed to match the offset of the other. Offset adjustment, however, slightly degrades the gain, common-mode and power-supply rejection match between the two op amps. Fortu-

nately, the guaranteed offset voltage match of the LT1002 is very low, in most applications offset adjustment will be unnecessary.

### Standard Adjustment

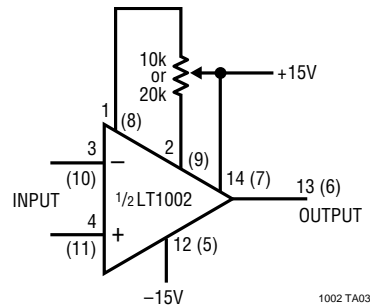

### Improved Sensitivity Adjustment

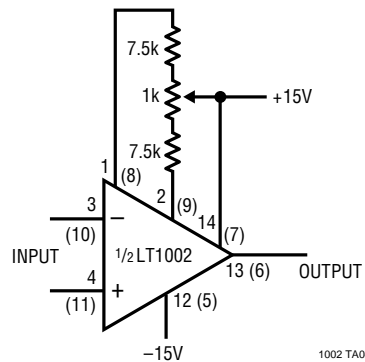



## APPLICATIONS INFORMATION

### Test Circuit for Offset Voltage and its Drift with Temperature

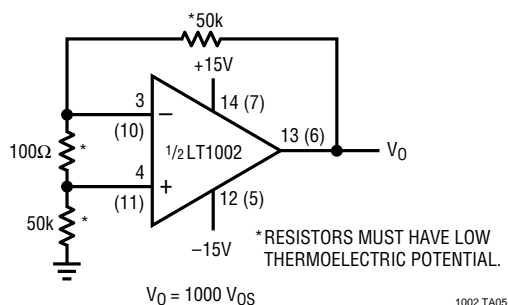

### 0.1Hz to 10Hz Noise Test Circuit

The device under test should be warmed up for three minutes and shielded from air currents. Turn the device 180° to measure the noise of side B.

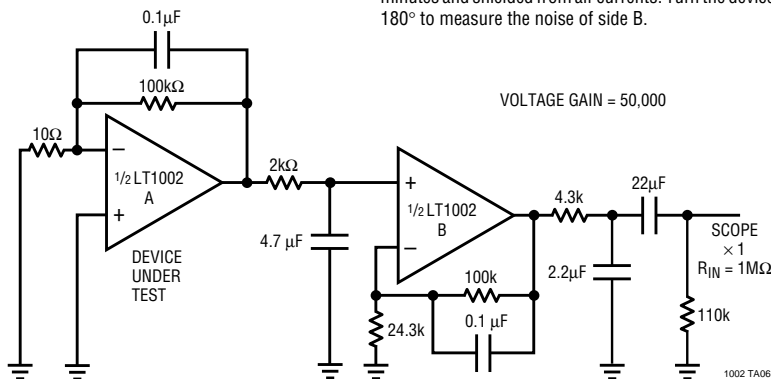

(Peak to Peak noise measured in 10 Sec interval)

This circuit is also used as burn-in configuration for the LT1002, with supply voltages increased to  $\pm 20V$ .

Unless proper care is exercised, thermocouple effects, caused by temperature gradients across dissimilar metals at the contacts to the input terminals, can exceed the inherent drift of the amplifier. Air currents should be minimized, package leads should be short, the two input leads should be as close together as possible and maintained at the same temperature.

### Channel Separation

This parameter is defined as the ratio of the change in input offset voltage of one amplifier to the change in output voltage of the other amplifier causing the offset change.

At low frequencies the LT1002's channel separation is an almost unmeasurable 148dB. As frequency increases, pin to pin capacitance of the package, between the output of one amplifier and the inputs of the other, becomes dominant. Since these pins are non-adjacent, the capacitance is only 0.02pF. To maintain the LT1002's excellent channel separation at higher frequencies, the socket and PC board capacitances should be minimized.

### Power supplies

The LT1002 is specified over a wide range of power supply voltages from  $\pm 3V$  to  $\pm 18V$ . Operation with lower supplies is possible, down to  $\pm 1.2V$  (two Ni-Cad batteries). However, with  $\pm 1.2V$  supplies, the device is stable only in closed loop gains of +2 or higher (or inverting gain of one or higher).

The  $V+$  supply terminals are completely independent and may be powered by separate supplies if desired (this approach, however, would sacrifice the advantages of the power supply rejection ratio matching). The  $V-$  supply terminals are both connected to the common substrate and must be tied to the same voltage. Both  $V-$  pins should be used.

## APPLICATIONS INFORMATION

**Advantages of Matched Dual Op Amps** In many applications the performance of a system depends on the matching between two operational amplifiers rather than the individual characteristics of the two op amps. Two or three op amp instrumentation amplifiers, tracking voltage references and low drift active filters are some of the circuits requiring matching between two op amps.

The well-known triple op amp configuration illustrates these concepts. Output offset is a function of the difference between the offsets of the two halves of the LT1002. This error cancellation principle holds for a considerable number of input referred parameters in addition to offset voltage and its drift with temperature. Input bias current will be the average of the two non-inverting input currents ( $I_B^+$ ). The difference between these two currents ( $I_{OS}^+$ ) is the offset current of the instrumentation amplifier. The difference between the inverting input currents ( $I_{OS}^-$ ) will cause errors flowing through R1, R2, and R3. Common-mode and power supply rejections will be dependent only on the match between the two amplifiers (assuming perfect resistor matching).

The concepts of common mode and power supply rejection ratio match ( $\Delta CMRR$  and  $\Delta PSRR$ ) are best demonstrated with a numerical example:

Assume  $CMRR_A = +1.0\mu V/V$  or 120dB,  
and  $CMRR_B = +0.75\mu V/V$  or 122.5dB,  
then  $\Delta CMRR = 0.25\mu V/V$  or 132dB;  
if  $CMRR_B = -0.75\mu V/V$  which is still 122.5dB,  
then  $\Delta CMRR = 1.75\mu V/V$  or 115dB.

Clearly, the LT1002, by specifying and guaranteeing all of these matching parameters, can significantly improve the performance of matching dependent circuits.

Three Op Amp Instrumentation Amplifier

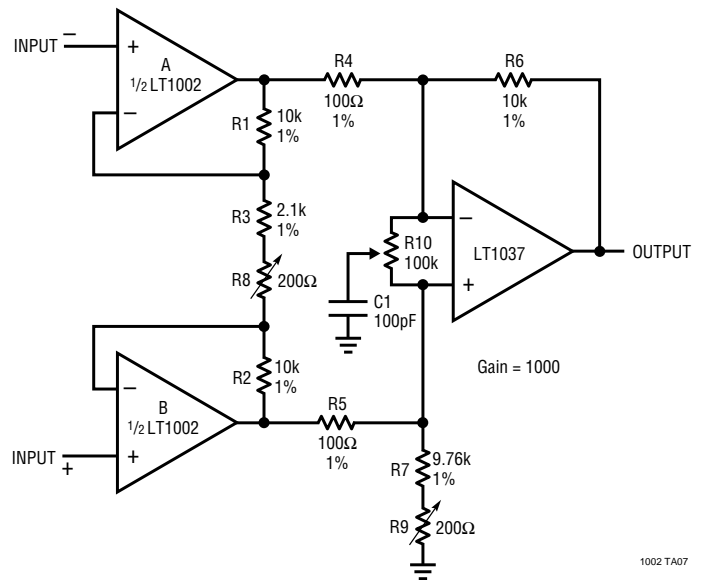

- Trim R8 for gain
- Trim R9 for DC common mode rejection
- Trim R10 for AC common mode rejection

Typical performance of the instrumentation amplifier:

- Input offset voltage = 25 $\mu V$
- Input bias current = 0.7nA
- Input resistance = 200 G $\Omega$
- Input offset current = 0.6nA
- Input noise = 0.5 $\mu V$  p-p
- Power bandwidth ( $V_0 = \pm 10V$ ) = 80kHz

## APPLICATIONS INFORMATION

Precision  $\pm 10V$  Reference

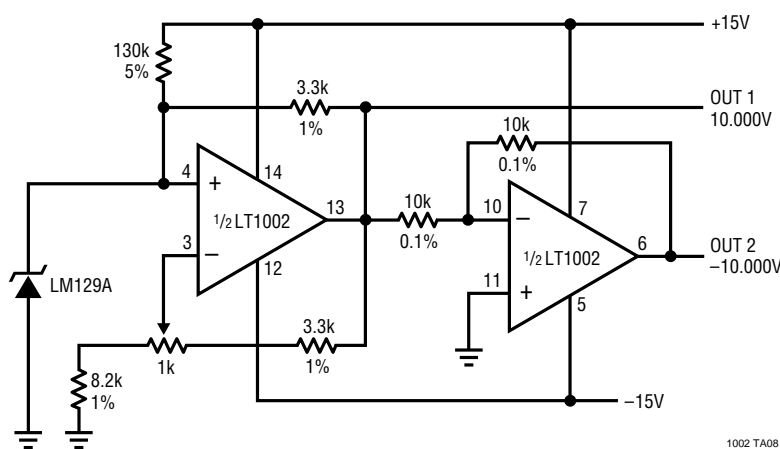

1002 TA08

The LT1002 contributes less than 5% of the total drift with temperature, noise and long term drift of the reference.

The accuracy of the  $-10V$  output is limited by the matching of the two 10k resistors.

Dual Limit Microvolt Comparator

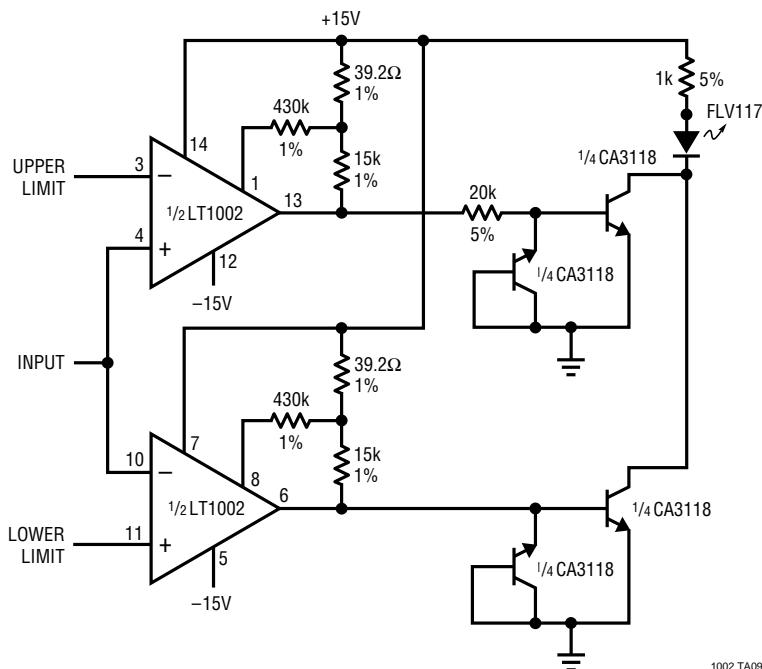

1002 TA09

When the upper or lower limit is exceeded the LED lights up. Positive feedback to one of the nulling terminals creates 5 to 20 $\mu V$  of hysteresis on both amplifiers. This

feedback changes the offset voltage of the LT1002 by less than 5 $\mu V$ . Therefore, the basic accuracy of the comparator is limited only by the low offset voltage of the LT1002.

APPLICATIONS INFORMATION

Two Op Amp Instrumentation Amplifier

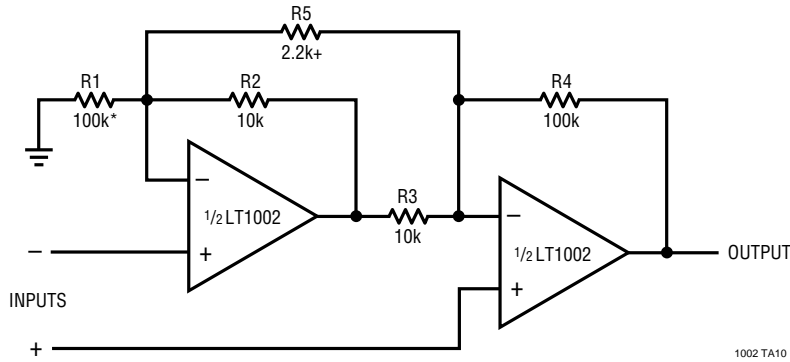

\* TRIM FOR COMMON-MODE REJECTION  
 + TRIM FOR GAIN

$$\text{Gain} = \frac{R4}{R3} \left[ 1 + \frac{1}{2} \left( \frac{R2}{R1} + \frac{R3}{R4} \right) + \frac{R2 + R3}{R5} \right] \approx 100$$

Precision Amplifier Drives 500Ω Load to ±10V

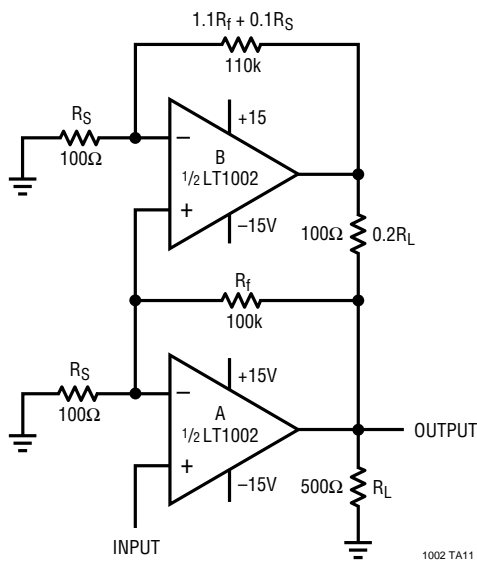

This application utilizes the guaranteed 10mA load driving capability of the LT1002. The offset voltage of amplifier A is the offset of the configuration. Amplifier B provides the additional 10mA load current. When load resistor  $R_L$  is removed, amplifier A sinks this current without affecting accuracy. In the gain of 1000 configuration shown, approximately 0.3% gain accuracy can be realized.

APPLICATIONS INFORMATION

Dead Zone Generator

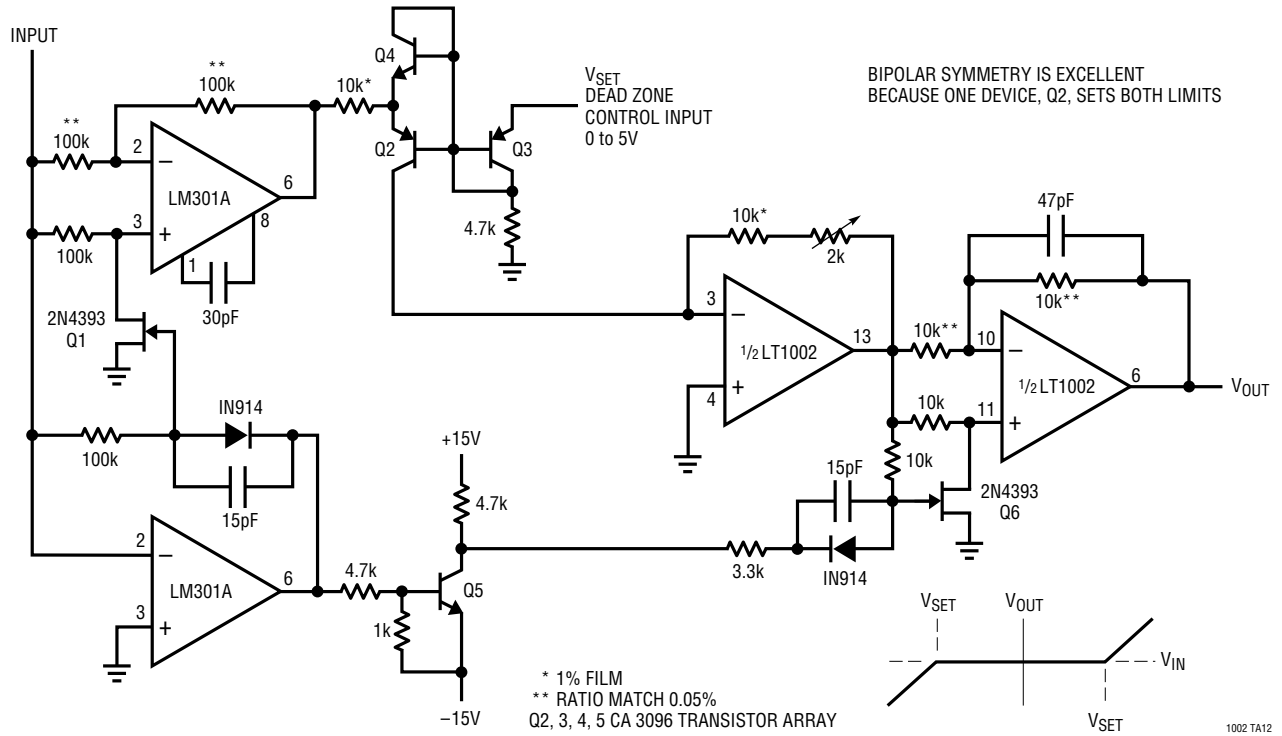

Precision Absolute Value Circuit

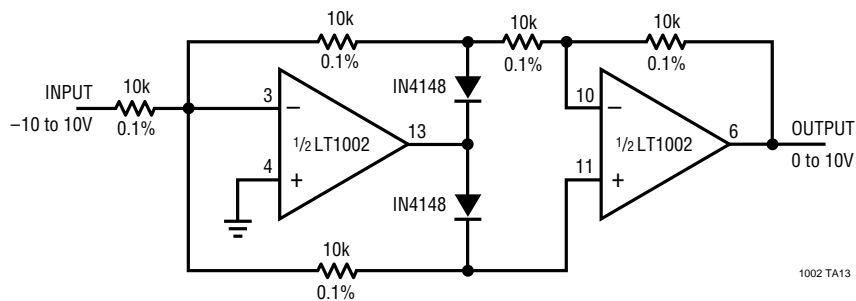

APPLICATIONS INFORMATION

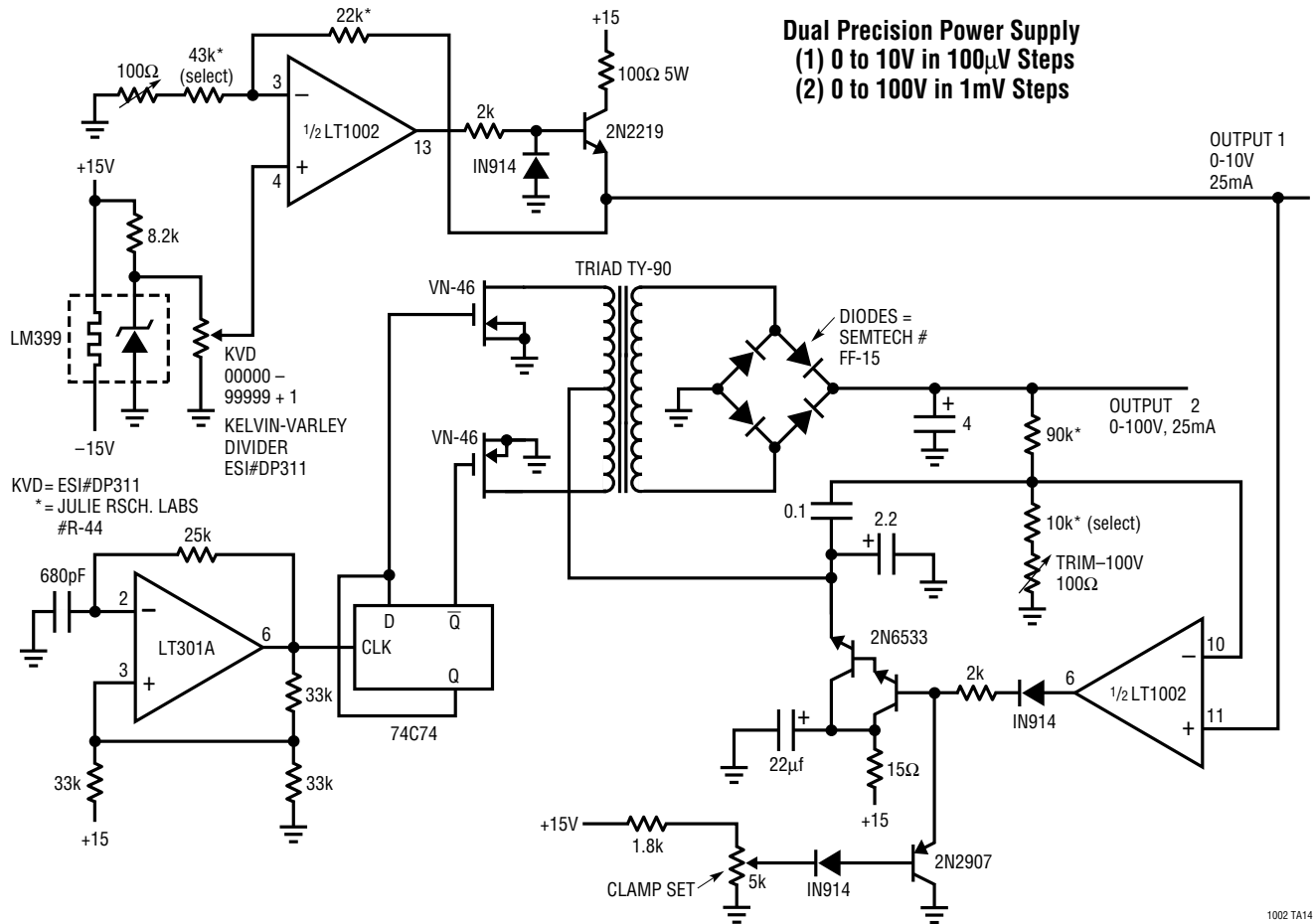

1002 TA14

# SCHEMATIC DIAGRAM

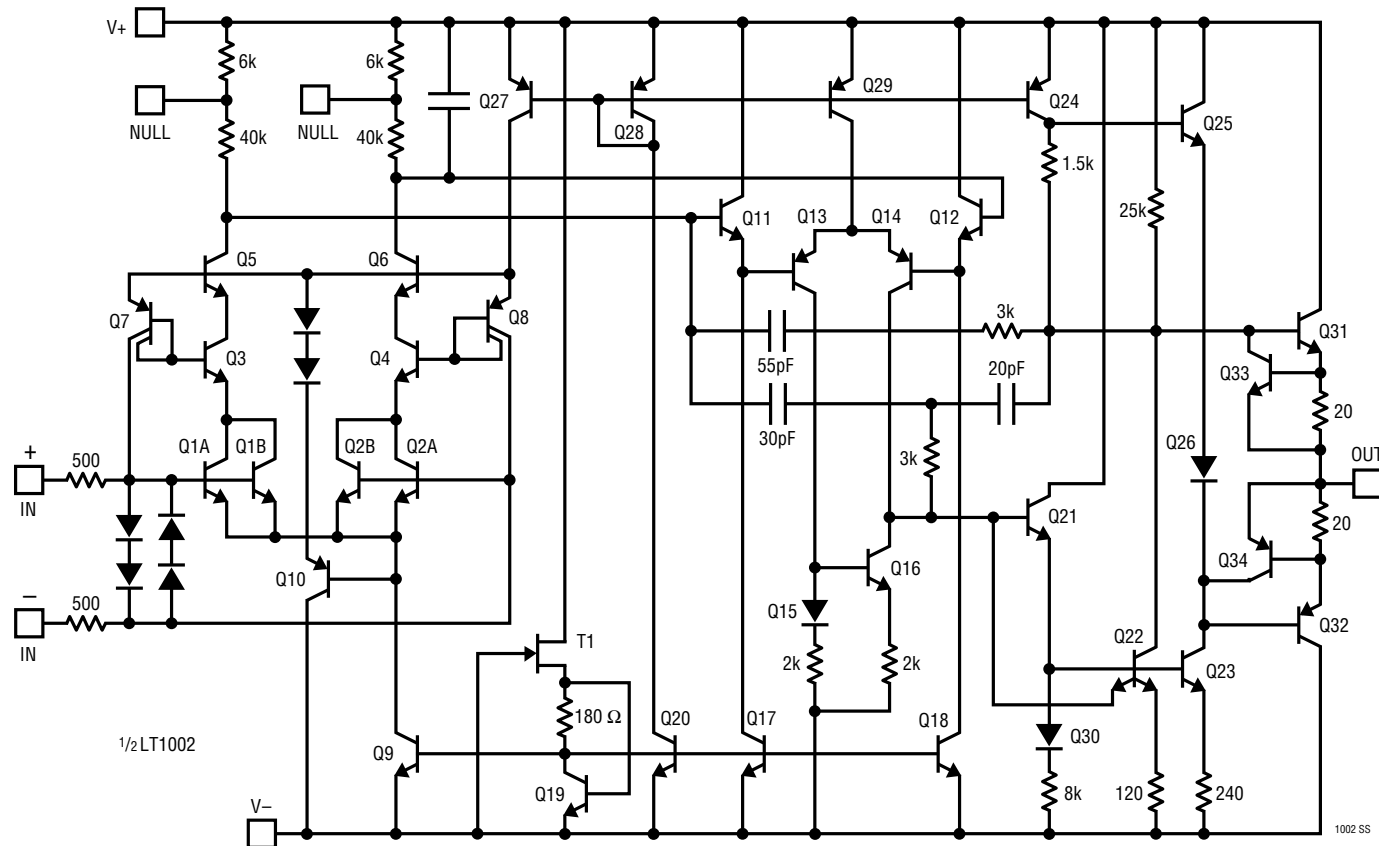

# PACKAGE DESCRIPTION Dimensions in inches (millimeters) unless otherwise noted.

**N Package**  
**14-Lead PDIP (Narrow 0.300)**  
 (LTC DWG # 05-08-1510)

**J Package**  
**14-Lead CERDIP (Narrow 0.300, Hermetic)**  
 (LTC DWG # 05-08-1110)

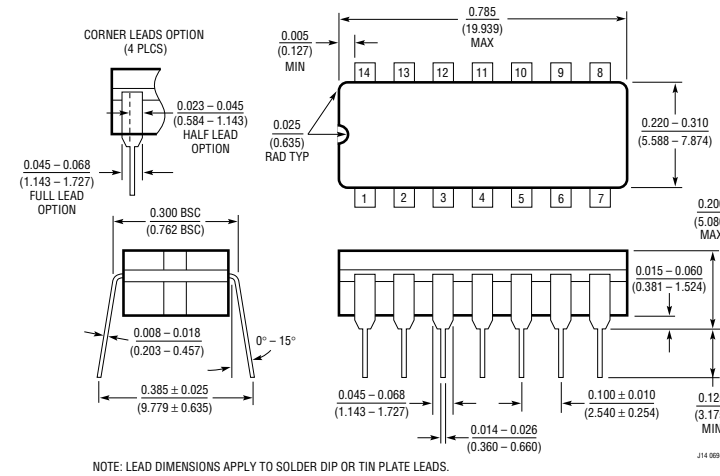
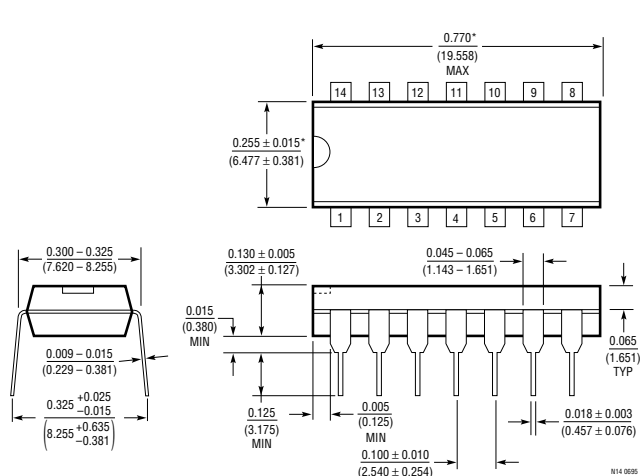

\*THESE DIMENSIONS DO NOT INCLUDE MOLD FLASH OR PROTRUSIONS. MOLD FLASH OR PROTRUSIONS SHALL NOT EXCEED 0.010 INCH (0.254mm)

NOTE: LEAD DIMENSIONS APPLY TO SOLDER DIP OR TIN PLATE LEADS.

	T <sub>JMAX</sub>	θ <sub>JA</sub>
LT1002ACN LT1002CN	125°C	100°C/W

	T <sub>JMAX</sub>	θ <sub>JA</sub>
LT1002ACJ LT1002CJ	125°C	100°C/W
LT1002AMJ LT1002MJ	125°C	100°C/W

