



# LSM303DLM

## Sensor module: 3-axis accelerometer and 3-axis magnetometer

Preliminary data

### Features

- Analog supply voltage: 2.16 V to 3.6 V
- Digital supply voltage IOs: 1.8 V
- Power-down mode
- 3 magnetic field channels and 3 acceleration channels
- $\pm 1.3$  to  $\pm 8.1$  gauss magnetic field full-scale
- $\pm 2 g / \pm 4 g / \pm 8 g$  dynamically selectable full-scale
- High performance g-sensor
- I<sup>2</sup>C serial interface
- 2 independent programmable interrupt generators for free-fall and motion detection
- Accelerometer sleep-to-wakeup function
- 6D orientation detection
- ECOPACK<sup>®</sup>, RoHS, and “Green” compliant

### Applications

- Compensated compass
- Map rotation
- Position detection
- Motion-activated functions
- Free-fall detection
- Intelligent power-saving for handheld devices
- Display orientation
- Gaming and virtual reality input devices
- Impact recognition and logging
- Vibration monitoring and compensation

### Description

The LSM303DLM is a system-in-package featuring a 3D digital linear acceleration sensor and a 3D digital magnetic sensor.

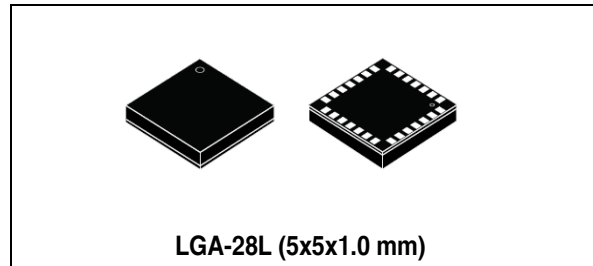

The various sensing elements are manufactured by using specialized micromachining processes, while the IC interfaces are realized using a CMOS technology that allows the design of a dedicated circuit which is trimmed to better match the sensing element characteristics. The LSM303DLM has a linear acceleration full-scale of  $\pm 2 g / \pm 4 g / \pm 8 g$  and a magnetic field full-scale of  $\pm 1.3 / \pm 1.9 / \pm 2.5 / \pm 4.0 / \pm 4.7 / \pm 5.6 / \pm 8.1$  gauss, both fully selectable by the user.

The LSM303DLM includes an I<sup>2</sup>C serial bus interface that supports standard mode (100 kHz) and fast mode (400 kHz). The system can be configured to generate an interrupt signal by inertial wakeup/free-fall events, as well as by the position of the device itself. Thresholds and timing of interrupt generators are programmable on the fly by the end user.

Magnetic and accelerometer parts can be enabled or put into power-down mode separately. The LSM303DLM is available in a plastic land grid array package (LGA), and is guaranteed to operate over an extended temperature range from -40 to +85 °C.

Table 1. Device summary

Part number	Temp. range [°C]	Package	Packing
LSM303DLM	-40 to +85	LGA-28	Tray
LSM303DLMTR			Tape and reel

# Contents

- 1      Block diagram and pin description ..... 5**
  - 1.1    Block diagram ..... 5
  - 1.2    Pin description ..... 6
  
- 2      Module specifications ..... 8**
  - 2.1    Sensor characteristics ..... 8
  - 2.2    Electrical characteristics ..... 9
  - 2.3    Communication interface characteristics ..... 10
    - 2.3.1    Sensor I<sup>2</sup>C - inter IC control interface ..... 10
  
- 3      Absolute maximum ratings ..... 11**
  
- 4      Terminology ..... 12**
  - 4.1    Linear acceleration sensitivity ..... 12
  - 4.2    Zero-g level ..... 12
  - 4.3    Sleep-to-wakeup ..... 12
  
- 5      Functionality ..... 13**
  - 5.1    Factory calibration ..... 13
  
- 6      Application hints ..... 14**
  - 6.1    External capacitors ..... 14
  - 6.2    Soldering information ..... 15
  - 6.3    High current wiring effects ..... 15
  
- 7      Digital interfaces ..... 16**
  - 7.1    I<sup>2</sup>C serial interface ..... 16
    - 7.1.1    I<sup>2</sup>C operation ..... 17
    - 7.1.2    Linear acceleration digital interface ..... 18
    - 7.1.3    Magnetic field digital interface ..... 18
  
- 8      Register mapping ..... 20**
  
- 9      Register description ..... 22**

9.1	Linear acceleration register description	22
9.1.1	CTRL_REG1_A (20h)	22
9.1.2	CTRL_REG2_A (21h)	23
9.1.3	CTRL_REG3_A (22h)	24
9.1.4	CTRL_REG4_A (23h)	25
9.1.5	CTRL_REG5_A (24h)	26
9.1.6	HP_FILTER_RESET_A (25h)	26
9.1.7	REFERENCE_A (26h)	26
9.1.8	STATUS_REG_A(27h)	27
9.1.9	OUT_X_L_A (28h), OUT_X_H_A (29h)	27
9.1.10	OUT_Y_L_A (2Ah), OUT_Y_H_A (2Bh)	27
9.1.11	OUT_Z_L_A (2Ch), OUT_Z_H_A (2Dh)	27
9.1.12	INT1_CFG_A (30h)	28
9.1.13	INT1_SRC_A (31h)	29
9.1.14	INT1_THS_A (32h)	29
9.1.15	INT1_DURATION_A (33h)	29
9.1.16	INT2_CFG_A (34h)	30
9.1.17	INT2_SRC_A (35h)	31
9.1.18	INT2_THS_A (36h)	31
9.1.19	INT2_DURATION_A (37h)	32
9.2	Magnetic field sensing register description	32
9.2.1	CRA_REG_M (00h)	32
9.2.2	CRB_REG_M (01h)	32
9.2.3	MR_REG_M (02h)	33
9.2.4	OUT_X_H_M (03), OUT_X_LH_M (04h)	33
9.2.5	OUT_Z_H_M (05), OUT_Z_L_M (06h)	34
9.2.6	OUT_Y_H_M (07), OUT_Y_L_M (08h)	34
9.2.7	SR_REG_M (09h)	34
9.2.8	IR_REG_M (0Ah/0Bh/0Ch)	34
9.2.9	WHO_AM_I_M (0F)	34
<b>10</b>	<b>Package information</b>	<b>35</b>
<b>11</b>	<b>Revision history</b>	<b>36</b>

## List of tables

Table 1.	Device summary . . . . .	1
Table 2.	Pin description . . . . .	5
Table 3.	Sensor characteristics . . . . .	7
Table 4.	Electrical characteristics . . . . .	8
Table 5.	I <sup>2</sup> C slave timing values . . . . .	9
Table 6.	Absolute maximum ratings . . . . .	10
Table 7.	Serial interface pin description . . . . .	15
Table 8.	Serial interface pin description . . . . .	15
Table 9.	Transfer when master is writing one byte to slave . . . . .	16
Table 10.	Transfer when master is writing multiple bytes to slave . . . . .	16
Table 11.	Transfer when master is receiving (reading) one byte of data from slave . . . . .	16
Table 12.	SAD and read/write patterns. . . . .	17
Table 13.	Transfer when master is receiving (reading) multiple bytes of data from slave . . . . .	17
Table 14.	SAD and read/write patterns. . . . .	17
Table 15.	Register address map. . . . .	19
Table 16.	CTRL_REG1_A register . . . . .	21
Table 17.	CTRL_REG1_A description . . . . .	21
Table 18.	Power mode and low-power output data rate configurations . . . . .	21
Table 19.	Normal-mode output data rate configurations and low-pass cut-off frequencies . . . . .	22
Table 20.	CTRL_REG2_A register . . . . .	22
Table 21.	CTRL_REG2_A description . . . . .	22
Table 22.	High-pass filter mode configuration . . . . .	23
Table 23.	High-pass filter cut-off frequency configuration . . . . .	23
Table 24.	CTRL_REG3_A register . . . . .	23
Table 25.	CTRL_REG3_A description . . . . .	23
Table 26.	Data signal on INT 1 and INT 2 pad . . . . .	24
Table 27.	CTRL_REG4_A register . . . . .	24
Table 28.	CTRL_REG4_A description . . . . .	24
Table 29.	CTRL_REG5_A register . . . . .	25
Table 30.	CTRL_REG5_A description . . . . .	25
Table 31.	Sleep-to-wakeup configuration . . . . .	25
Table 32.	REFERENCE_A register . . . . .	25
Table 33.	REFERENCE_A description. . . . .	25
Table 34.	STATUS_REG_A register . . . . .	26
Table 35.	STATUS_REG_A description. . . . .	26
Table 36.	INT1_CFG_A register . . . . .	27
Table 37.	INT1_CFG_A description . . . . .	27
Table 38.	Interrupt 1 source configurations . . . . .	27
Table 39.	INT1_SRC register . . . . .	28
Table 40.	INT1_SRC_A description . . . . .	28
Table 41.	INT1_THS register . . . . .	28
Table 42.	INT1_THS description . . . . .	28
Table 43.	INT1_DURATION_A register . . . . .	28
Table 44.	INT2_DURATION_A description . . . . .	29
Table 45.	INT2_CFG_A register . . . . .	29
Table 46.	INT2_CFG_A description . . . . .	29
Table 47.	Interrupt mode configuration. . . . .	29
Table 48.	INT2_SRC_A register . . . . .	30

---

Table 49.	INT2_SRC_A description . . . . .	30
Table 50.	INT2_THS register . . . . .	30
Table 51.	INT2_THS description . . . . .	30
Table 52.	INT2_DURATION_A register . . . . .	31
Table 53.	INT2_DURATION_A description . . . . .	31
Table 54.	CRA_REG_M register . . . . .	31
Table 55.	CRA_REG_M description . . . . .	31
Table 56.	Data rate configurations . . . . .	31
Table 57.	CRA_REG register . . . . .	31
Table 58.	Gain setting . . . . .	32
Table 59.	MR_REG . . . . .	32
Table 60.	MR_REG description . . . . .	32
Table 61.	Magnetic sensor operating mode . . . . .	32
Table 62.	SR register . . . . .	33
Table 63.	SR register description . . . . .	33
Table 64.	IRA_REG_M . . . . .	33
Table 65.	IRB_REG_M . . . . .	33
Table 66.	IRC_REG_M . . . . .	33
Table 67.	WHO_AM_I_M . . . . .	33
Table 68.	Revision history . . . . .	35

# 1 Block diagram and pin description

## 1.1 Block diagram

Figure 1. Block diagram

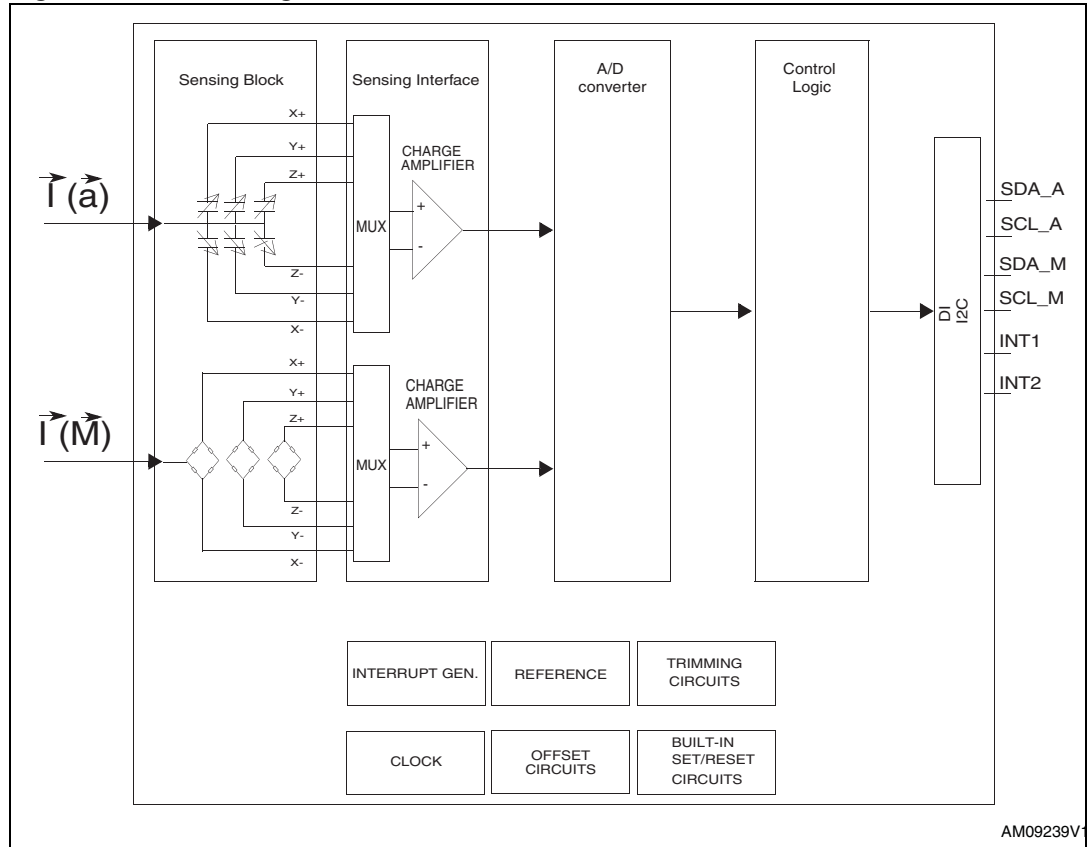

## 1.2 Pin description

Figure 2. Pin connection

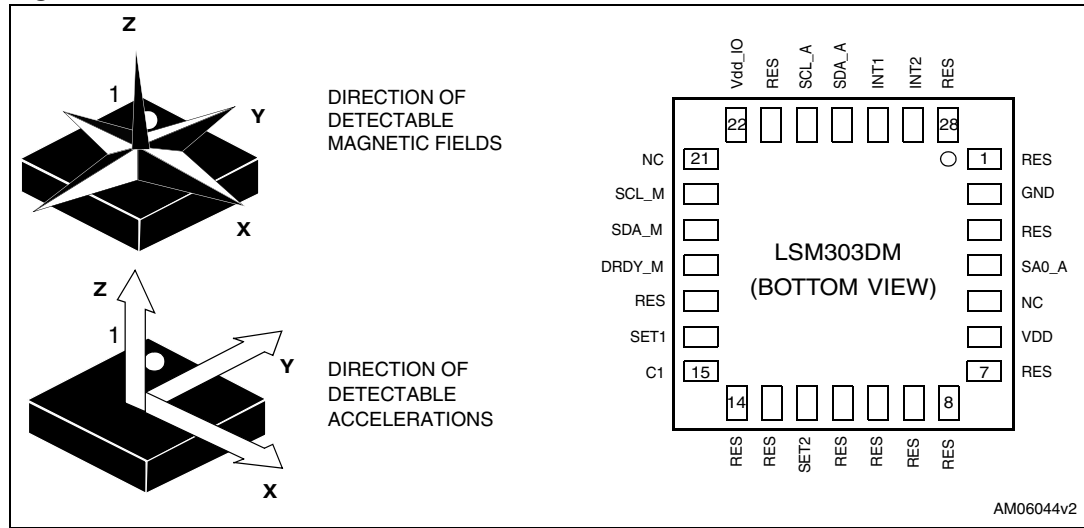

Table 2. Pin description

Pin#	Name	Function
1	Reserved	Connect to GND
2	GND	0 V supply
3	Reserved	Connect to GND
4	SA0_A	Linear acceleration signal I <sup>2</sup> C less significant bit of the device address (SA0)
5	NC	Internally not connected
6	Vdd	Power supply
7	Reserved	Connect to Vdd
8	Reserved	Leave unconnected
9	Reserved	Leave unconnected
10	Reserved	Leave unconnected
11	Reserved	Leave unconnected
12	SET2	S/R capacitor connection (C2)
13	Reserved	Leave unconnected
14	Reserved	Leave unconnected
15	C1	Reserved capacitor connection (C1)
16	SET1	S/R capacitor connection (C2)
17	Reserved	Connect to GND
18	DRDY_M	Magnetic signal interface data ready
19	SDA_M	Magnetic signal interface I <sup>2</sup> C serial data (SDA)

**Table 2. Pin description (continued)**

Pin#	Name	Function
20	SCL_M	Magnetic signal interface I <sup>2</sup> C serial clock (SCL)
21	NC	Internally not connected
22	Vdd_IO	Signal interface power supply for I/O pins
23	Reserved	Connect to Vdd_IO
24	SCL_A	Linear acceleration signal interface I <sup>2</sup> C serial clock (SCL)
25	SDA_A	Linear acceleration signal interface I <sup>2</sup> C serial data (SDA)
26	INT1	Inertial Interrupt 1
27	INT2	Inertial Interrupt 2
28	Reserved	Connect to GND



## 2 Module specifications

### 2.1 Sensor characteristics

@ V<sub>dd</sub> = 2.5 V, T = 25 °C unless otherwise noted<sup>(a)</sup>.

**Table 3. Sensor characteristics**

Symbol	Parameter	Test conditions	Min.	Typ. <sup>(1)</sup>	Max.	Unit
LA_FS	Linear acceleration measurement range <sup>(2)</sup>	FS bit set to 00		±2.0		g
		FS bit set to 01		±4.0		
		FS bit set to 11		±8.0		
M_FS	Magnetic measurement range	GN bits set to 001		±1.3		gauss
		GN bits set to 010		±1.9		
		GN bits set to 011		±2.5		
		GN bits set to 100		±4.0		
		GN bits set to 101		±4.7		
		GN bits set to 110		±5.6		
		GN bits set to 111		±8.1		
LA_So	Linear acceleration sensitivity	FS bit set to 00 12-bit representation		1		mg/digit
		FS bit set to 01 12-bit representation		2		
		FS bit set to 11 12-bit representation		3.9		
M_GN	Magnetic gain setting	GN bits set to 001 (X,Y)		1100		LSB/ gauss
		GN bits set to 001 (Z)		980		
		GN bits set to 010 (X,Y)		855		
		GN bits set to 010 (Z)		760		
		GN bits set to 011 (X,Y)		670		
		GN bits set to 011 (Z)		600		
		GN bits set to 100 (X,Y)		450		
		GN bits set to 100 (Z)		400		
		GN bits set to 101 (X,Y)		400		
		GN bits set to 101 (Z)		355		
		GN bits set to 110 (X,Y)		330		
		GN bits set to 110 (Z)		295		
		GN bits set to 111 <sup>(2)</sup> (X,Y)		230		
		GN bits set to 111 <sup>(2)</sup> (Z)		205		

a. The product is factory calibrated at 2.5 V. The operational power supply range is from 2.16 V to 3.6 V.

**Table 3. Sensor characteristics (continued)**

Symbol	Parameter	Test conditions	Min.	Typ. <sup>(1)</sup>	Max.	Unit
LA_TCS <sub>0</sub>	Linear acceleration sensitivity change vs. temperature	FS bit set to 00		±0.01		%/°C
LA_TyOff	Linear acceleration typical Zero-g level offset accuracy <sup>(3),(4)</sup>	FS bit set to 00		±60		mg
LA_TCOff	Linear acceleration Zero-g level change vs. temperature	Max. delta from 25 °C		±0.5		mg/°C
M_CAS	Magnetic cross-axis sensitivity	Cross field = 0.5 gauss H applied = ±3 gauss		±1		%FS/ gauss
M_EF	Maximum exposed field	No permitting effect on zero reading			10000	gauss
M_R	Magnetic resolution			5		mgauss
M_DF	Disturbing field	Sensitivity starts to degrade. Use S/R pulse to restore sensitivity			20	gauss
Top	Operating temperature range		-40		+85	°C

1. Typical specifications are not guaranteed.
2. Verified by wafer level test and measurement of initial offset and sensitivity.
3. Typical Zero-g level offset value after MSL3 preconditioning.
4. Offset can be eliminated by enabling the built-in high-pass filter.

## 2.2 Electrical characteristics

@ V<sub>dd</sub> = 2.5 V, T = 25 °C unless otherwise noted.

**Table 4. Electrical characteristics**

Symbol	Parameter	Test conditions	Min.	Typ. <sup>(1)</sup>	Max.	Unit
V <sub>dd</sub>	Supply voltage	-	2.16		3.6	V
V <sub>dd_IO</sub>	Module power supply for I/O		1.71	1.8	V <sub>dd</sub> +0.1	V
I <sub>dd</sub>	Current consumption in normal mode <sup>(2)</sup>			360		µA
I <sub>ddPdn</sub>	Current consumption in power-down mode				2	µA
Top	Operating temperature range			-40		+85

1. Typical specifications are not guaranteed.
2. Magnetic sensor setting ODR = 7.5 Hz. Accelerometer sensor ODR = 50 Hz.

## 2.3 Communication interface characteristics

### 2.3.1 Sensor I<sup>2</sup>C - inter IC control interface

Subject to general operating conditions for V<sub>dd</sub> and top.

Table 5. I<sup>2</sup>C slave timing values

Symbol	Parameter	I <sup>2</sup> C standard mode <sup>(1)</sup>		I <sup>2</sup> C fast mode <sup>(1)</sup>		Unit
		Min.	Max.	Min.	Max.	
f <sub>(SCL)</sub>	SCL clock frequency	0	100	0	400	KHz
t <sub>w(SCLL)</sub>	SCL clock low time	4.7		1.3		μs
t <sub>w(SCLH)</sub>	SCL clock high time	4.0		0.6		
t <sub>su(SDA)</sub>	SDA setup time	250		100		ns
t <sub>h(SDA)</sub>	SDA data hold time	0.01	3.45	0.01	0.9	μs
t <sub>r(SDA)</sub> t <sub>r(SCL)</sub>	SDA and SCL rise time		1000	20 + 0.1C <sub>b</sub> <sup>(2)</sup>	300	ns
t <sub>f(SDA)</sub> t <sub>f(SCL)</sub>	SDA and SCL fall time		300	20 + 0.1C <sub>b</sub> <sup>(2)</sup>	300	
t <sub>h(ST)</sub>	START condition hold time	4		0.6		μs
t <sub>su(SR)</sub>	Repeated START condition setup time	4.7		0.6		
t <sub>su(SP)</sub>	STOP condition setup time	4		0.6		
t <sub>w(SP:SR)</sub>	Bus free time between STOP and START condition	4.7		1.3		

1. Data based on standard I<sup>2</sup>C protocol requirement, not tested in production.

2. C<sub>b</sub> = total capacitance of one bus line, in pF.

Figure 3. I<sup>2</sup>C slave timing diagram (b)

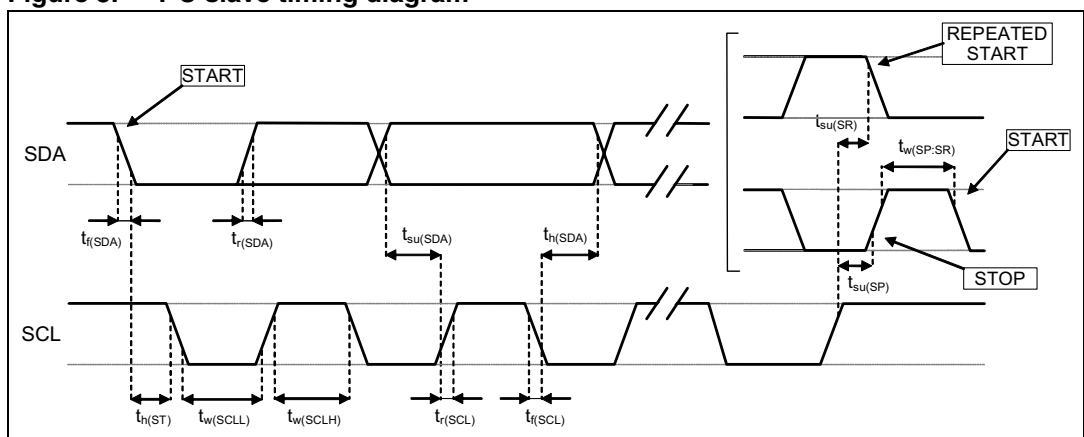

b. Measurement points are done at 0.2·V<sub>dd\_IO</sub> and 0.8·V<sub>dd\_IO</sub>, for both ports.

### 3 Absolute maximum ratings

Stresses above those listed as “absolute maximum ratings” may cause permanent damage to the device. This is a stress rating only and functional operation of the device under these conditions is not implied. Exposure to maximum rating conditions for extended periods may affect device reliability.

**Table 6. Absolute maximum ratings**

Symbol	Ratings	Maximum value	Unit
Vdd	Supply voltage	-0.3 to 4.8	V
Vdd_IO	I/O pins supply voltage	-0.3 to 4.8	V
Vin	Input voltage on any control pin (SCL, SDA)	-0.3 to Vdd_IO +0.3	V
A <sub>POW</sub>	Acceleration (any axis, powered, Vdd = 2.5 V)	3,000 for 0.5 ms	<i>g</i>
		10,000 for 0.1 ms	<i>g</i>
A <sub>UNP</sub>	Acceleration (any axis, unpowered)	3,000 for 0.5 ms	<i>g</i>
		10,000 for 0.1 ms	<i>g</i>
T <sub>OP</sub>	Operating temperature range	-40 to +85	°C
T <sub>STG</sub>	Storage temperature range	-40 to +125	°C



This is a mechanical shock sensitive device, improper handling can cause permanent damage to the part.



This is an ESD sensitive device, improper handling can cause permanent damage to the part.

## 4 Terminology

### 4.1 Linear acceleration sensitivity

Linear acceleration sensitivity describes the gain of the accelerometer sensor and can be determined by applying 1 *g* acceleration to it. As the sensor can measure DC accelerations, this can be done easily by pointing the selected axis towards the ground, noting the output value, rotating the sensor 180 degrees (pointing to the sky) and noting the output value again. By doing so, a  $\pm 1$  *g* acceleration is applied to the sensor. Subtracting the larger output value from the smaller one, and dividing the result by 2, leads to the actual sensitivity of the sensor. This value changes very little over temperature and over time. The sensitivity tolerance describes the range of sensitivities of a large number of sensors.

### 4.2 Zero-*g* level

Zero-*g* level Offset (LA\_TyOff) describes the deviation of an actual output signal from the ideal output signal if no linear acceleration is present. A sensor in steady-state on a horizontal surface measures 0 *g* on both the X and Y axes, whereas the Z axis measures 1 *g*. Ideally, the output is in the middle of the dynamic range of the sensor (content of OUT registers 00h, data expressed as 2's complement number). A deviation from the ideal value in this case is called Zero-*g* offset. Offset is, to some extent, a result of stress to the MEMS sensor and therefore the offset can slightly change after mounting the sensor onto a printed circuit board or exposing it to extensive mechanical stress. Offset changes little over temperature, see "Linear acceleration Zero-*g* level change vs. temperature" (LA\_TCOff) in [Table 3](#). The Zero-*g* level tolerance (TyOff) describes the standard deviation of the range of Zero-*g* levels of a group of sensors.

### 4.3 Sleep-to-wakeup

The "sleep-to-wakeup" function, in conjunction with low-power mode, allows further reduction of system power consumption and the development of new smart applications. The LSM303DLM may be set to a low-power operating mode, characterized by lower data rate refreshing. In this way, the device, even if sleeping, continues sensing acceleration and generating interrupt requests.

When the sleep-to-wakeup function is activated, the LSM303DLM is able to automatically wake up as soon as the interrupt event has been detected, increasing the output data rate and bandwidth. With this feature the system may be efficiently switched from low-power mode to full-performance depending on user-selectable positioning and acceleration events, therefore ensuring power-saving and flexibility.

## 5 Functionality

The LSM303DLM is a system-in-package featuring a 3D digital linear acceleration and 3D digital magnetic field detection sensor.

The system includes specific sensing elements and an IC interface capable of measuring both the linear acceleration and the magnetic field applied on it and to provide a signal to the external world through an I<sup>2</sup>C serial interface with separated digital output.

The sensing system is manufactured using specialized micromachining processes, while the IC interfaces are realized using a CMOS technology that allows the design of a dedicated circuit which is trimmed to better match the sensing element characteristics.

The LSM303DLM features two data-ready signals (RDY) which indicate when a new set of measured acceleration data and magnetic data are available, therefore simplifying data synchronization in the digital system that uses the device.

The LSM303DLM may also be configured to generate an inertial wakeup and free-fall interrupt signal according to a programmed acceleration event along the enabled axes. Both free-fall and wakeup can be used simultaneously on two different accelerometer interrupts.

### 5.1 Factory calibration

The IC interface is factory calibrated for linear acceleration sensitivity (LA\_So), and linear acceleration Zero-g level (LA\_TyOff).

The trimming values are stored inside the device in non-volatile memory. When the device is turned on, the trimming parameters are downloaded into the registers to be used during normal operation. This allows the use of the device without further calibration.

## 6 Application hints

Figure 4. LSM303DLM electrical connection - recommended for I<sup>2</sup>C fast mode

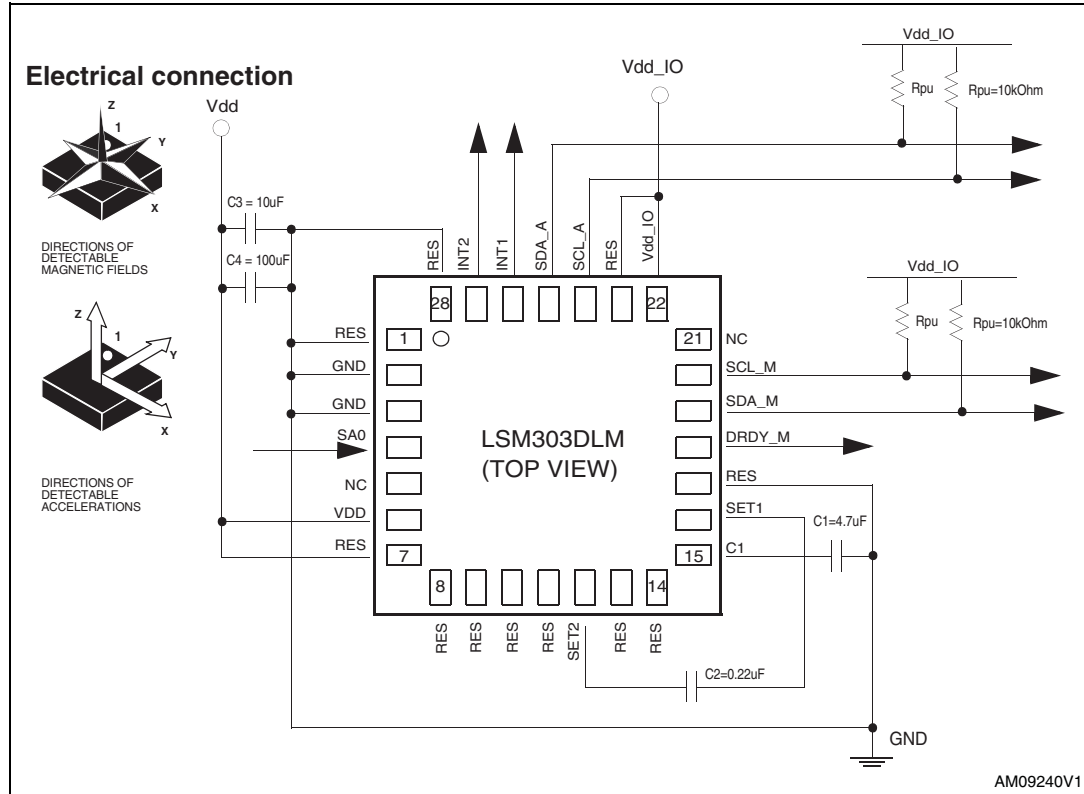

### 6.1 External capacitors

The C1 and C2 external capacitors should have a low SR value ceramic type construction. Reservoir capacitor C1 is nominally 4.7 µF in capacitance, with the set/reset capacitor C2 nominally 0.22 µF in capacitance.

The device core is supplied through the Vdd line. Power supply decoupling capacitors (C4=100 nF ceramic, C3=10 µF Al) should be placed as near as possible to the supply pin of the device (common design practice). All the voltage and ground supplies must be present at the same time to obtain proper behavior of the IC (refer to [Figure 4](#)).

The functionality of the device and the measured acceleration/magnetic field data is selectable and accessible through the I<sup>2</sup>C interface.

The functions, the threshold, and the timing of the two interrupt pins (INT 1 and INT 2) can be completely programmed by the user through the I<sup>2</sup>C interface.

## 6.2 Soldering information

The LGA package is compliant with the ECOPACK<sup>®</sup>, RoHS and “Green” standard. It is qualified for soldering heat resistance according to JEDEC J-STD-020.

Leave “pin 1 indicator” unconnected during soldering.

Land pattern and soldering recommendations are available at [www.st.com](http://www.st.com).

## 6.3 High current wiring effects

High current in the wiring and printed circuit traces can be the cause of errors in magnetic field measurements for compassing.

Conductor-generated magnetic fields add to the Earth’s magnetic field, creating errors in compass heading computation.

Keep currents that are higher than 10 mA a few millimeters further away from the sensor IC.



## 7 Digital interfaces

The registers embedded inside the LSM303DLM are accessible through two separate I<sup>2</sup>C serial interfaces; one for the accelerometer core and the other for the magnetometer core. The two interfaces can be connected together on the PCB.

**Table 7. Serial interface pin description**

Pin name	Pin description
SCL_A	I <sup>2</sup> C serial clock (SCL) for accelerometer
SDA_A	I <sup>2</sup> C serial data (SDA) for accelerometer
SCL_M	I <sup>2</sup> C serial clock (SCL) for magnetometer
SDA_M	I <sup>2</sup> C serial data (SDA) for magnetometer

### 7.1 I<sup>2</sup>C serial interface

The LSM303DLM I<sup>2</sup>C is a bus slave. The I<sup>2</sup>C is employed to write the data into the registers whose content can also be read back.

The relevant I<sup>2</sup>C terminology is given in the table below.

**Table 8. Serial interface pin description**

Term	Description
Transmitter	The device which sends data to the bus
Receiver	The device which receives data from the bus
Master	The device which initiates a transfer, generates clock signals, and terminates a transfer
Slave	The device addressed by the master

There are two signals associated with the I<sup>2</sup>C bus; the serial clock line (SCL) and the serial data line (SDA). The latter is a bidirectional line used for sending and receiving the data to/from the interface.

### 7.1.1 I<sup>2</sup>C operation

The transaction on the bus is started through a START (ST) signal. A START condition is defined as a HIGH to LOW transition on the data line while the SCL line is held HIGH. After this has been transmitted by the master, the bus is considered busy. The next byte of data transmitted after the start condition contains the address of the slave in the first 7 bits and the 8<sup>th</sup> bit tells whether the master is receiving data from the slave or transmitting data to the slave. When an address is sent, each device in the system compares the first seven bits after a start condition with its address. If they match, the device considers itself addressed by the master.

Data transfer with acknowledge is mandatory. The transmitter must release the SDA line during the acknowledge pulse. The receiver must then pull the data line LOW so that it remains stable low during the HIGH period of the acknowledge clock pulse. A receiver which has been addressed is obliged to generate an acknowledge after each byte of data received.

The I<sup>2</sup>C embedded inside the LSM303DLM behaves like a slave device and the following protocol must be adhered to. After the start condition (ST) a slave address is sent. Once a slave acknowledge (SAK) has been returned, an 8-bit sub-address (SUB) is transmitted; the 7 LSBs represent the actual register address while the MSB enables address auto-increment. If the MSb of the SUB field is '1', the SUB (register address) is automatically increased to allow multiple data read/write.

**Table 9. Transfer when master is writing one byte to slave**

Master	ST	SAD + W		SUB		DATA		SP
Slave			SAK		SAK		SAK	

**Table 10. Transfer when master is writing multiple bytes to slave**

Master	ST	SAD + W		SUB		DATA		DATA		SP
Slave			SAK		SAK		SAK		SAK	

**Table 11. Transfer when master is receiving (reading) one byte of data from slave**

Master	ST	SAD + W		SUB		SR	SAD + R			NMAK	SP
Slave			SAK		SAK			SAK	DATA		

Data are transmitted in byte format (DATA). Each data transfer contains 8 bits. The number of bytes transferred per transfer is unlimited. Data is transferred with the most significant bit (MSb) first. If a receiver cannot receive another complete byte of data until it has performed some other function, it can hold the clock line SCL LOW to force the transmitter into a wait state. Data transfer only continues when the receiver is ready for another byte and releases the data line. If a slave receiver does not acknowledge the slave address (i.e. it is not able to receive because it is performing a real-time function) the data line must be left HIGH by the slave. The master can then abort the transfer. A LOW to HIGH transition on the SDA line while the SCL line is HIGH is defined as a STOP condition. Each data transfer must be terminated by the generation of a STOP (SP) condition.

### 7.1.2 Linear acceleration digital interface

For linear acceleration, the default (factory) 7-bit slave address is 001100xb. The SDO/SA0 pad can be used to modify the least significant bit of the device address. If the SA0 pad is connected to voltage supply, the LSB is '1' (address 0011001b) otherwise, if the SA0 pad is connected to ground, the LSB value is '0' (address 0011000b). This solution permits connecting and addressing two different accelerometers to the same I<sup>2</sup>C lines.

The slave address is completed with a read/write bit. If the bit is '1' (read), a repeated START (SR) condition must be issued after the two sub-address bytes; if the bit is '0' (write), the master transmits to the slave with the direction unchanged. [Table 12](#) explains how the SAD+read/write bit pattern is composed, listing all the possible configurations.

**Table 12. SAD and read/write patterns**

Command	SAD[6:1]	SAD[0] = SA0	R/W	SAD+R/W
Read	001100	0	1	00110001 (31h)
Write	001100	0	0	00110000 (30h)
Read	001100	1	1	00110011 (33h)
Write	001100	1	0	00110010 (32h)

In order to read multiple bytes, it is necessary to assert the most significant bit of the sub-address field. In other words, SUB(7) must be equal to 1 while SUB(6-0) represents the address of the first register to be read.

In the presented communication format, MAK is master acknowledge and NMAK is no master acknowledge.

**Table 13. Transfer when master is receiving (reading) multiple bytes of data from slave**

Master	ST	SAD+W		SUB		SR	SAD+R			MAK		MAK		NMAK	SP
Slave			SAK		SAK			SAK	DATA		DATA		DATA		

### 7.1.3 Magnetic field digital interface

**For magnetic sensors the default (factory) 7-bit slave address is 0011110xb.**

The slave address is completed with a read/write bit. If the bit is '1' (read), a repeated START (SR) condition must be issued after the two sub-address bytes; if the bit is '0' (write), the master transmits to the slave with the direction unchanged. [Table 14](#) explains how the SAD is composed.

**Table 14. SAD and read/write patterns**

Command	SAD[6:0]	R/W	SAD+R/W
Read	0011110	1	00111101 (3Dh)
Write	0011110	0	00111100 (3Ch)

### Magnetic signal interface reading/writing

The interface uses an address pointer to indicate which register location is to be read from or written to. These pointer locations are sent from the master to this slave device and succeed the 7-bit address plus 1 bit read/write identifier.

To minimize communication between the master and magnetic digital interface of LSM303DLM, the address pointer updates automatically without master intervention.

This automatic address pointer update has two additional features. First, when address 12 or higher is accessed, the pointer updates to address 00, and secondly, when address 08 is reached, the pointer rolls back to address 03. Logically, the address pointer operation functions as shown below.

If (address pointer = 08) then the address pointer = 03

Or else, if (address pointer  $\geq$  12) then the address pointer = 0

Or else, (address pointer) = (address pointer) + 1

The address pointer value itself cannot be read via the I<sup>2</sup>C bus.

Any attempt to read an invalid address location returns 0, and any write to an invalid address location, or an undefined bit within a valid address location, is ignored by this device.

## 8 Register mapping

[Table 15](#) provides a listing of the 8-bit registers embedded in the device and the related addresses:

**Table 15. Register address map**

Name	Slave address	Type	Register address		Default	Comment
			Hex	Binary		
Reserved (do not modify)	<a href="#">Table 12</a>	--	00 - 1F	--	--	Reserved
CTRL_REG1_A	<a href="#">Table 12</a>	rw	20	010 0000	00000111	
CTRL_REG2_A	<a href="#">Table 12</a>	rw	21	010 0001	00000000	
CTRL_REG3_A	<a href="#">Table 12</a>	rw	22	010 0010	00000000	
CTRL_REG4_A	<a href="#">Table 12</a>	rw	23	010 0011	00000000	
CTRL_REG5_A	<a href="#">Table 12</a>	rw	24	010 0100	00000000	
HP_FILTER_RESET_A	<a href="#">Table 12</a>	r	25	010 0101	--	Dummy register
REFERENCE_A	<a href="#">Table 12</a>	rw	26	010 0110	00000000	
STATUS_REG_A	<a href="#">Table 12</a>	r	27	010 0111	00000000	
OUT_X_L_A	<a href="#">Table 12</a>	r	28	010 1000	output	
OUT_X_H_A	<a href="#">Table 12</a>	r	29	010 1001	output	
OUT_Y_L_A	<a href="#">Table 12</a>	r	2A	010 1010	output	
OUT_Y_H_A	<a href="#">Table 12</a>	r	2B	010 1011	output	
OUT_Z_L_A	<a href="#">Table 12</a>	r	2C	010 1100	output	
OUT_Z_H_A	<a href="#">Table 12</a>	r	2D	010 1101	output	
Reserved (do not modify)	<a href="#">Table 12</a>	--	2E - 2F	--	--	Reserved
INT1_CFG_A	<a href="#">Table 12</a>	rw	30	011 0000	00000000	
INT1_SOURCE_A	<a href="#">Table 12</a>	r	31	011 0001	00000000	
INT1_THS_A	<a href="#">Table 12</a>	rw	32	011 0010	00000000	
INT1_DURATION_A	<a href="#">Table 12</a>	rw	33	011 0011	00000000	
INT2_CFG_A	<a href="#">Table 12</a>	rw	34	011 0100	00000000	
INT2_SOURCE_A	<a href="#">Table 12</a>	r	35	011 0101	00000000	
INT2_THS_A	<a href="#">Table 12</a>	rw	36	011 0110	00000000	
INT2_DURATION_A	<a href="#">Table 12</a>	rw	37	011 0111	00000000	
Reserved (do not modify)	<a href="#">Table 12</a>	--	38 - 3F	--	--	Reserved
CRA_REG_M	<a href="#">Table 14</a>	rw	00	00000000	00010000	
CRB_REG_M	<a href="#">Table 14</a>	rw	01	00000001	00100000	
MR_REG_M	<a href="#">Table 14</a>	rw	02	00000010	00000011	

Table 15. Register address map (continued)

Name	Slave address	Type	Register address		Default	Comment
			Hex	Binary		
OUT_X_H_M	<a href="#">Table 14</a>	r	03	00000011	output	
OUT_X_L_M	<a href="#">Table 14</a>	r	04	00000100	output	
OUT_Y_H_M	<a href="#">Table 14</a>	r	07	00000101	output	
OUT_Y_L_M	<a href="#">Table 14</a>	r	08	00000110	output	
OUT_Z_H_M	<a href="#">Table 14</a>	r	05	00000111	output	
OUT_Z_L_M	<a href="#">Table 14</a>	r	06	00001000	output	
SR_REG_Mg	<a href="#">Table 14</a>	r	09	00001001	00000000	
IRA_REG_M	<a href="#">Table 14</a>	r	0A	00001010	01001000	
IRB_REG_M	<a href="#">Table 14</a>	r	0B	00001011	00110100	
IRC_REG_M	<a href="#">Table 14</a>	r	0C	00001100	00110011	
Reserved (do not modify)	<a href="#">Table 14</a>	--	0D - 0E	--	--	Reserved
WHO_AM_I_M	<a href="#">Table 14</a>	r	0F	00001111	00111100	Who am I ID
Reserved (do not modify)	<a href="#">Table 14</a>	--	10 - 3A	--	--	Reserved

Registers marked as “reserved” must not be changed. Writing to these registers may cause permanent damage to the device.

The content of the registers that are loaded at boot should not be changed. They contain the factory calibrated values. Their content is automatically restored when the device is powered up.

## 9 Register description

The device contains a set of registers which are used to control its behavior and to retrieve acceleration data. The register address, made up of 7 bits, is used to identify them and to write the data through the serial interface.

### 9.1 Linear acceleration register description

#### 9.1.1 CTRL\_REG1\_A (20h)

**Table 16. CTRL\_REG1\_A register**

PM2	PM1	PM0	DR1	DR0	Zen	Yen	Xen
-----	-----	-----	-----	-----	-----	-----	-----

**Table 17. CTRL\_REG1\_A description**

PM2 - PM0	Power mode selection. Default value: 000 (000: power-down; others: refer to <a href="#">Table 18</a> )
DR1, DR0	Data rate selection. Default value: 00 (00:50 Hz; others: refer to <a href="#">Table 19</a> )
Zen	Z axis enable. Default value: 1 (0: Z axis disabled; 1: Z axis enabled)
Yen	Y axis enable. Default value: 1 (0: Y axis disabled; 1: Y axis enabled)
Xen	X axis enable. Default value: 1 (0: X axis disabled; 1: X axis enabled)

**PM** bits allow selection between power-down and two operating active modes. The device is in power-down mode when the PD bits are set to “000” (default value after boot). [Table 18](#) shows all the possible power mode configurations and respective output data rates. Output data in the low-power modes are computed with a low-pass filter cut-off frequency defined by DR1 and DR0 bits.

**DR** bits, in normal-mode operation, select the data rate at which acceleration samples are produced. In low-power mode they define the output data resolution. [Table 19](#) shows all the possible configurations for the DR1 and DR0 bits.

**Table 18. Power mode and low-power output data rate configurations**

PM2	PM1	PM0	Power mode selection	Output data rate [Hz] ODR <sub>LP</sub>
0	0	0	Power-down	--
0	0	1	Normal mode	ODR
0	1	0	Low-power	0.5

**Table 18. Power mode and low-power output data rate configurations (continued)**

PM2	PM1	PM0	Power mode selection	Output data rate [Hz] ODR <sub>LP</sub>
0	1	1	Low-power	1
1	0	0	Low-power	2
1	0	1	Low-power	5
1	1	0	Low-power	10

**Table 19. Normal-mode output data rate configurations and low-pass cut-off frequencies**

DR1	DR0	Output data rate [Hz] ODR	Low-pass filter cut-off frequency [Hz]
0	0	50	37
0	1	100	74
1	0	400	292
1	1	1000	780

### 9.1.2 CTRL\_REG2\_A (21h)

**Table 20. CTRL\_REG2\_A register**

BOOT	HPM1	HPM0	FDS	HPen2	HPen1	HPCF1	HPCF0
------	------	------	-----	-------	-------	-------	-------

**Table 21. CTRL\_REG2\_A description**

BOOT	Reboot memory content. Default value: 0 (0: normal mode; 1: reboot memory content)
HPM1, HPM0	High-pass filter mode selection. Default value: 00 (00: normal mode; others: refer to <a href="#">Table 22</a> )
FDS	Filtered data selection. Default value: 0 (0: internal filter bypassed; 1: data from internal filter sent to output register)
HPen2	High-pass filter enabled for Interrupt 2 source. Default value: 0 (0: filter bypassed; 1: filter enabled)
HPen1	High-pass filter enabled for Interrupt 1 source. Default value: 0 (0: filter bypassed; 1: filter enabled)
HPCF1, HPCF0	High-pass filter cut-off frequency configuration. Default value: 00 (00: HPC=8; 01: HPC=16; 10: HPC=32; 11: HPC=64)

The **BOOT** bit is used to refresh the content of internal registers stored in the Flash memory block. At device power-up, the content of the Flash memory block is transferred to the internal registers related to trimming functions to permit good device behavior. If, for any



reason, the content of the trimming registers has changed, it is sufficient to use this bit to restore the correct values. When the BOOT bit is set to '1' the content of the internal Flash is copied to the corresponding internal registers and is used to calibrate the device. These values are factory-trimmed and are different for every accelerometer. They permit good device behavior and normally do not have to be modified. At the end of the boot process, the BOOT bit is again set to '0'.

**Table 22. High-pass filter mode configuration**

HPM1	HPM0	High-pass filter mode
0	0	Normal mode (reset reading HP_RESET_FILTER)
0	1	Reference signal for filtering
1	0	Normal mode (reset reading HP_RESET_FILTER)

**HPCF[1:0]**. These bits are used to configure the high-pass filter cut-off frequency ( $f_t$ ), which is given by:

$$f_t = \ln\left(1 - \frac{1}{HPC}\right) \cdot \frac{f_s}{2\pi}$$

The equation can be simplified to the following approximated equation:

$$f_t = \frac{f_s}{6 \cdot HPC}$$

**Table 23. High-pass filter cut-off frequency configuration**

HPcoeff2,1	$f_t$ [Hz] Data rate = 50 Hz	$f_t$ [Hz] Data rate = 100 Hz	$f_t$ [Hz] Data rate = 400 Hz	$f_t$ [Hz] Data rate = 1000 Hz
00	1	2	8	20
01	0.5	1	4	10
10	0.25	0.5	2	5
11	0.125	0.25	1	2.5

### 9.1.3 CTRL\_REG3\_A (22h)

**Table 24. CTRL\_REG3\_A register**

IHL	PP_OD	LIR2	I2_CFG1	I2_CFG0	LIR1	I1_CFG1	I1_CFG0
-----	-------	------	---------	---------	------	---------	---------

**Table 25. CTRL\_REG3\_A description**

IHL	Interrupt active high, low. Default value: 0 (0: active high; 1: active low)
PP_OD	Push-pull/open drain selection on interrupt pad. Default value 0. (0: push-pull; 1: open drain)

**Table 25. CTRL\_REG3\_A description (continued)**

LIR2	Latch interrupt request on INT2_SRC register, with INT2_SRC register cleared by reading INT2_SRC itself. Default value: 0. (0: interrupt request not latched; 1: interrupt request latched)
I2_CFG1, I2_CFG0	Data signal on INT 2 pad control bits. Default value: 00. (see <a href="#">Table 26</a> )
LIR1	Latch interrupt request on INT1_SRC register, with INT1_SRC register cleared by reading INT1_SRC register. Default value: 0. (0: interrupt request not latched; 1: interrupt request latched)
I1_CFG1, I1_CFG0	Data signal on INT 1 pad control bits. Default value: 00. (see <a href="#">Table 26</a> )

**Table 26. Data signal on INT 1 and INT 2 pad**

I1(2)_CFG1	I1(2)_CFG0	INT 1(2) Pad
0	0	Interrupt 1 (2) source
0	1	Interrupt 1 source OR Interrupt 2 source
1	0	Data ready
1	1	Boot running

### 9.1.4 CTRL\_REG4\_A (23h)

**Table 27. CTRL\_REG4\_A register**

BDU	BLE	FS1	FS0	0	0	0 <sup>(1)</sup>	---
-----	-----	-----	-----	---	---	------------------	-----

1. This bit must be set to '0' for correct working of the device.

**Table 28. CTRL\_REG4\_A description**

BDU	Block data update. Default value: 0 (0: continuous update; 1: output registers not updated between MSB and LSB reading)
BLE	Big/little endian data selection. Default value 0. (0: data LSB @ lower address; 1: data MSB @ lower address)
FS1, FS0	Full-scale selection. Default value: 00. (00: $\pm 2 g$ ; 01: $\pm 4 g$ ; 11: $\pm 8 g$ )

The **BDU** bit is used to inhibit output register updates between the reading of the upper and lower register parts. In default mode (BDU = '0'), the lower and upper register parts are updated continuously. If it is not certain whether to read faster than the output data rate, it is recommended to set BDU bit to '1'. In this way, after the reading of the lower (upper) register part, the content of that output register is not updated until the upper (lower) part is read also. This feature avoids reading LSB and MSB related to different samples.

### 9.1.5 CTRL\_REG5\_A (24h)

**Table 29. CTRL\_REG5\_A register**

0	0	0	0	0	0	TurnOn1	TurnOn0
---	---	---	---	---	---	---------	---------

**Table 30. CTRL\_REG5\_A description**

TurnOn1, TurnOn0	Turn-on mode selection for sleep-to-wakeup function. Default value: 00.
---------------------	---

TurnOn bits are used for turning on the sleep-to-wakeup function.

**Table 31. Sleep-to-wakeup configuration**

TurnOn1	TurnOn0	Sleep-to-wakeup status
0	0	Sleep-to-wakeup function is disabled
1	1	Turned on: the device is in low-power mode (ODR is defined in CTRL_REG1_A)

By setting the TurnOn [1:0] bits to 11, the “sleep-to-wakeup” function is enabled. When an interrupt event occurs, the device goes into normal mode, increasing the ODR to the value defined in CTRL\_REG1\_A. Although the device is in normal mode, CTRL\_REG1\_A content is not automatically changed to “normal mode” configuration.

### 9.1.6 HP\_FILTER\_RESET\_A (25h)

Dummy register. Reading at this address instantaneously zeroes the content of the internal high-pass filter. If the high-pass filter is enabled, all three axes are instantaneously set to 0 *g*. This makes it possible to surmount the settling time of the high-pass filter.

### 9.1.7 REFERENCE\_A (26h)

**Table 32. REFERENCE\_A register**

Ref7	Ref6	Ref5	Ref4	Ref3	Ref2	Ref1	Ref0
------	------	------	------	------	------	------	------

**Table 33. REFERENCE\_A description**

Ref7 - Ref0	Reference value for high-pass filter. Default value: 00h.
-------------	---

This register sets the acceleration value taken as a reference for the high-pass filter output.

When the filter is turned on (at least one FDS, HPen2, or HPen1 bit is equal to ‘1’) and HPM bits are set to “01”, filter out is generated taking this value as a reference.

**9.1.8 STATUS\_REG\_A(27h)****Table 34. STATUS\_REG\_A register**

ZYXOR	ZOR	YOR	XOR	ZYXDA	ZDA	YDA	XDA
-------	-----	-----	-----	-------	-----	-----	-----

**Table 35. STATUS\_REG\_A description**

ZYXOR	X, Y, and Z axis data overrun. Default value: 0 (0: no overrun has occurred, 1: new data has overwritten the previous one)
ZOR	Z axis data overrun. Default value: 0 (0: no overrun has occurred, 1: new data for the Z-axis has overwritten the previous one)
YOR	Y axis data overrun. Default value: 0 (0: no overrun has occurred, 1: new data for the Y-axis has overwritten the previous one)
XOR	X axis data overrun. Default value: 0 (0: no overrun has occurred, 1: new data for the X-axis has overwritten the previous one)
ZYXDA	X, Y, and Z axis new data available. Default value: 0 (0: a new set of data is not yet available, 1: a new set of data is available)
ZDA	Z axis new data available. Default value: 0 (0: new data for the Z-axis is not yet available, 1: new data for the Z-axis is available)
YDA	Y axis new data available. Default value: 0 (0: new data for the Y-axis is not yet available, 1: new data for the Y-axis is available)
XDA	X axis new data available. Default value: 0 (0: new data for the X-axis is not yet available, 1: new data for the X-axis is available)

**9.1.9 OUT\_X\_L\_A (28h), OUT\_X\_H\_A (29h)**

X-axis acceleration data. The value is expressed as 2's complement.

**9.1.10 OUT\_Y\_L\_A (2Ah), OUT\_Y\_H\_A (2Bh)**

Y-axis acceleration data. The value is expressed as 2's complement.

**9.1.11 OUT\_Z\_L\_A (2Ch), OUT\_Z\_H\_A (2Dh)**

Z-axis acceleration data. The value is expressed as 2's complement.

**9.1.12 INT1\_CFG\_A (30h)****Table 36. INT1\_CFG\_A register**

AOI	6D	ZHIE	ZLIE	YHIE	YLIE	XHIE	XLIE
-----	----	------	------	------	------	------	------

**Table 37. INT1\_CFG\_A description**

AOI	AND/OR combination of interrupt events. Default value: 0 (see <a href="#">Table 38</a> ).
6D	6-direction detection function enable. Default value: 0 (see <a href="#">Table 38</a> ).
ZHIE	Enable interrupt generation on Z high event. Default value: 0 (0: disable interrupt request, 1: enable interrupt request on measured accel. value higher than preset threshold)
ZLIE	Enable interrupt generation on Z low event. Default value: 0 (0: disable interrupt request, 1: enable interrupt request on measured accel. value lower than preset threshold)
YHIE	Enable interrupt generation on Y high event. Default value: 0 (0: disable interrupt request, 1: enable interrupt request on measured accel. value higher than preset threshold)
YLIE	Enable interrupt generation on Y low event. Default value: 0 (0: disable interrupt request, 1: enable interrupt request on measured accel. value lower than preset threshold)
XHIE	Enable interrupt generation on X high event. Default value: 0 (0: disable interrupt request, 1: enable interrupt request on measured accel. value higher than preset threshold)
XLIE	Enable interrupt generation on X low event. Default value: 0 (0: disable interrupt request, 1: enable interrupt request on measured accel. value lower than preset threshold)

Configuration register for Interrupt 1 source.

**Table 38. Interrupt 1 source configurations**

AOI	6D	Interrupt mode
0	0	OR combination of interrupt events
0	1	6-direction movement recognition
1	0	AND combination of interrupt events
1	1	6-direction position recognition

**9.1.13 INT1\_SRC\_A (31h)**

**Table 39. INT1\_SRC register**

0	IA	ZH	ZL	YH	YL	XH	XL
---	----	----	----	----	----	----	----

**Table 40. INT1\_SRC\_A description**

IA	Interrupt active. Default value: 0 (0: no interrupt has been generated, 1: one or more interrupts have been generated)
ZH	Z high. Default value: 0 (0: no interrupt, 1: Z high event has occurred)
ZL	Z low. Default value: 0 (0: no interrupt, 1: Z low event has occurred)
YH	Y high. Default value: 0 (0: no interrupt, 1: Y high event has occurred)
YL	Y low. Default value: 0 (0: no interrupt, 1: Y low event has occurred)
XH	X high. Default value: 0 (0: no interrupt, 1: X high event has occurred)
XL	X low. Default value: 0 (0: no interrupt, 1: X low event has occurred)

Interrupt 1 source register. Read-only register.

Reading at this address clears the INT1\_SRC\_A IA bit (and the interrupt signal on the INT 1 pin) and allows the refreshing of data in the INT1\_SRC\_A register if the latched option was chosen.

#### 9.1.14 INT1\_THS\_A (32h)

**Table 41. INT1\_THS register**

0	THS6	THS5	THS4	THS3	THS2	THS1	THS0
---	------	------	------	------	------	------	------

**Table 42. INT1\_THS description**

THS6 - THS0	Interrupt 1 threshold. Default value: 000 0000
-------------	--

#### 9.1.15 INT1\_DURATION\_A (33h)

**Table 43. INT1\_DURATION\_A register**

0	D6	D5	D4	D3	D2	D1	D0
---	----	----	----	----	----	----	----

**Table 44. INT2\_DURATION\_A description**

D6 - D0	Duration value. Default value: 000 0000
---------	---

The **D6 - D0** bits set the minimum duration of the Interrupt 2 event to be recognized. Duration steps and maximum values depend on the ODR chosen.

## 9.1.16 INT2\_CFG\_A (34h)

Table 45. INT2\_CFG\_A register

AOI	6D	ZHIE	ZLIE	YHIE	YLIE	XHIE	XLIE
-----	----	------	------	------	------	------	------

Table 46. INT2\_CFG\_A description

AOI	AND/OR combination of interrupt events. Default value: 0 (see <a href="#">Table 47</a> ).
6D	6-direction detection function enable. Default value: 0 (see <a href="#">Table 47</a> ).
ZHIE	Enable interrupt generation on Z high event. Default value: 0 (0: disable interrupt request, 1: enable interrupt request on measured accel. value higher than preset threshold)
ZLIE	Enable interrupt generation on Z low event. Default value: 0 (0: disable interrupt request, 1: enable interrupt request on measured accel. value lower than preset threshold)
YHIE	Enable interrupt generation on Y high event. Default value: 0 (0: disable interrupt request, 1: enable interrupt request on measured accel. value higher than preset threshold)
YLIE	Enable interrupt generation on Y low event. Default value: 0 (0: disable interrupt request, 1: enable interrupt request on measured accel. value lower than preset threshold)
XHIE	Enable interrupt generation on X high event. Default value: 0 (0: disable interrupt request, 1: enable interrupt request on measured accel. value higher than preset threshold)
XLIE	Enable interrupt generation on X low event. Default value: 0 (0: disable interrupt request, 1: enable interrupt request on measured accel. value lower than preset threshold)

Configuration register for Interrupt 2 source.

Table 47. Interrupt mode configuration

AOI	6D	Interrupt mode
0	0	OR combination of interrupt events
0	1	6-direction movement recognition
1	0	AND combination of interrupt events
1	1	6-direction position recognition

### 9.1.17 INT2\_SRC\_A (35h)

**Table 48. INT2\_SRC\_A register**

0	IA	ZH	ZL	YH	YL	XH	XL
---	----	----	----	----	----	----	----

**Table 49. INT2\_SRC\_A description**

IA	Interrupt active. Default value: 0 (0: no interrupt has been generated; 1: one or more interrupts have been generated)
ZH	Z high. Default value: 0 (0: no interrupt, 1: Z high event has occurred)
ZL	Z low. Default value: 0 (0: no interrupt; 1: Z low event has occurred)
YH	Y high. Default value: 0 (0: no interrupt, 1: Y high event has occurred)
YL	Y low. Default value: 0 (0: no interrupt, 1: Y low event has occurred)
XH	X high. Default value: 0 (0: no interrupt, 1: X high event has occurred)
XL	X Low. Default value: 0 (0: no interrupt, 1: X low event has occurred)

Interrupt 2 source register. Read-only register.

Reading at this address clears the INT2\_SRC\_A IA bit (and the interrupt signal on the INT 2 pin) and allows the refreshing of data in the INT2\_SRC\_A register if the latched option was chosen.

### 9.1.18 INT2\_THS\_A (36h)

**Table 50. INT2\_THS register**

0	THS6	THS5	THS4	THS3	THS2	THS1	THS0
---	------	------	------	------	------	------	------

**Table 51. INT2\_THS description**

THS6 - THS0	Interrupt 1 threshold. Default value: 000 0000
-------------	--

### 9.1.19 INT2\_DURATION\_A (37h)

**Table 52. INT2\_DURATION\_A register**

0	D6	D5	D4	D3	D2	D1	D0
---	----	----	----	----	----	----	----



**Table 53. INT2\_DURATION\_A description**

D6 - D0	Duration value. Default value: 000 0000
---------	---

The **D6 - D0** bits set the minimum duration of the Interrupt 2 event to be recognized. Duration time steps and maximum values depend on the ODR chosen.

## 9.2 Magnetic field sensing register description

### 9.2.1 CRA\_REG\_M (00h)

**Table 54. CRA\_REG\_M register**

0 <sup>(1)</sup>	0 <sup>(1)</sup>	0 <sup>(1)</sup>	DO2	DO1	DO0	0 <sup>(1)</sup>	0 <sup>(1)</sup>
------------------	------------------	------------------	-----	-----	-----	------------------	------------------

1. This bit must be set to '0' for correct working of the device.

**Table 55. CRA\_REG\_M description**

DO2 to DO0	Data output rate bits. These bits set the rate at which data is written to all three data output registers (refer to <a href="#">Table 56</a> ). Default value: 100
------------	---

**Table 56. Data rate configurations**

DO2	DO1	DO0	Minimum data output rate (Hz)
0	0	0	0.75
0	0	1	1.5
0	1	0	3.0
0	1	1	7.5
1	0	0	15
1	0	1	30
1	1	0	75
1	1	1	220

### 9.2.2 CRB\_REG\_M (01h)

**Table 57. CRA\_REG register**

GN2	GN1	GN0	0 <sup>(1)</sup>	0 <sup>(1)</sup>	0 <sup>(1)</sup>	0 <sup>(1)</sup>	0 <sup>(1)</sup>
-----	-----	-----	------------------	------------------	------------------	------------------	------------------

1. This bit must be set to '0' for correct working of the device.

**CRA\_REG description**

GN1-0	Gain configuration bits. The gain configuration is common for all channels (refer to <a href="#">Table 58</a> )
-------	---

**Table 58. Gain setting**

GN2	GN1	GN0	Sensor input field range [Gauss]	Gain X/Y and Z [LSB/Gauss]	Gain Z [LSB/Gauss]	Output range
0	0	1	±1.3	1100	980	0xF800–0x07FF (-2048–2047)
0	1	0	±1.9	855	760	
0	1	1	±2.5	670	600	
1	0	0	±4.0	450	400	
1	0	1	±4.7	400	355	
1	1	0	±5.6	330	295	
1	1	1	±8.1	230	205	

**9.2.3 MR\_REG\_M (02h)****Table 59. MR\_REG**

0 <sup>(1)</sup>	0 <sup>(1)</sup>	0 <sup>(1)</sup>	0 <sup>(1)</sup>	0 <sup>(1)</sup>	0 <sup>(1)</sup>	MD1	MD0
------------------	------------------	------------------	------------------	------------------	------------------	-----	-----

1. This bit must be set to '0' for correct working of the device

**Table 60. MR\_REG description**

MD1-0	Mode select bits. These bits select the operation mode of this device (refer to <a href="#">Table 61</a> )
-------	--

**Table 61. Magnetic sensor operating mode**

MD1	MD0	Mode
0	0	Continuous-conversion mode
0	1	Single-conversion mode
1	0	Sleep-mode. Device is placed in sleep-mode
1	1	Sleep-mode. Device is placed in sleep-mode

**9.2.4 OUT\_X\_H\_M (03), OUT\_X\_LH\_M (04h)**

X-axis magnetic field data. The value is expressed as 2's complement.

**9.2.5 OUT\_Z\_H\_M (05), OUT\_Z\_L\_M (06h)**

Z-axis magnetic field data. The value is expressed as 2's complement.

**9.2.6 OUT\_Y\_H\_M (07), OUT\_Y\_L\_M (08h)**

Y-axis magnetic field data. The value is expressed as 2's complement.

### 9.2.7 SR\_REG\_M (09h)

**Table 62. SR register**

--	--	--	--	--	--	LOCK	DRDY
----	----	----	----	----	----	------	------

**Table 63. SR register description**

LOCK	Data output register lock. Once a new set of measurements is available, this bit is set when the first magnetic field data register has been read.
DRDY	Data ready bit. This bit is when a new set of measurements is available.

### 9.2.8 IR\_REG\_M (0Ah/0Bh/0Ch)

**Table 64. IRA\_REG\_M**

0	1	0	0	1	0	0	0
---	---	---	---	---	---	---	---

**Table 65. IRB\_REG\_M**

0	0	1	1	0	1	0	0
---	---	---	---	---	---	---	---

**Table 66. IRC\_REG\_M**

0	0	1	1	0	0	1	1
---	---	---	---	---	---	---	---

### 9.2.9 WHO\_AM\_I\_M (0F)

**Table 67. WHO\_AM\_I\_M**

0	0	1	1	1	1	0	0
---	---	---	---	---	---	---	---

# 10 Package information

In order to meet environmental requirements, ST offers these devices in different grades of ECOPACK® packages, depending on their level of environmental compliance. ECOPACK specifications, grade definitions, and product status are available at: [www.st.com](http://www.st.com). ECOPACK is an ST trademark.

**Figure 5. LGA-28: mechanical data and package dimensions**

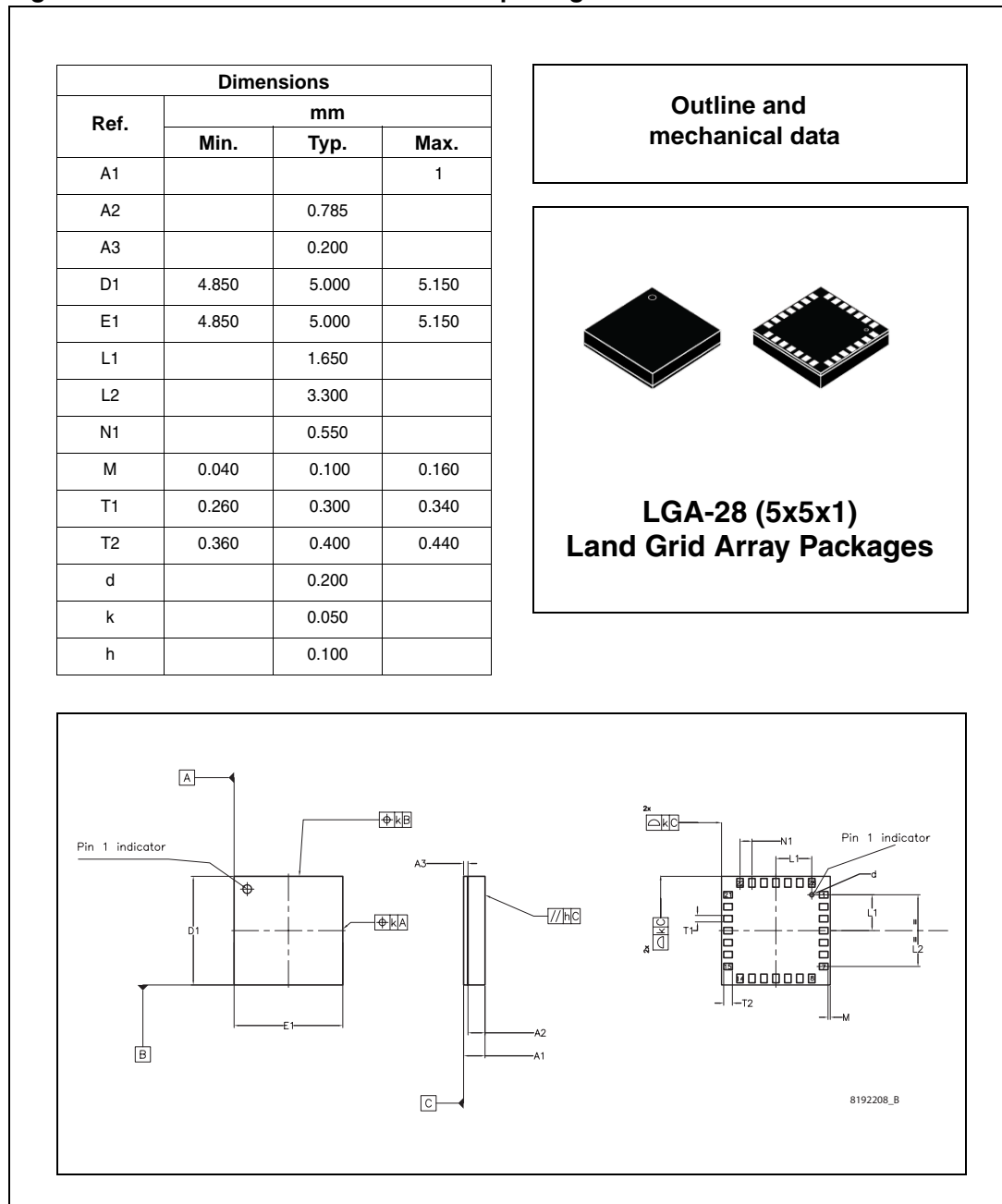

## 11 Revision history

**Table 68. Document revision history**

Date	Revision	Changes
11-Apr-2011	1	Initial release.

**Please Read Carefully:**

Information in this document is provided solely in connection with ST products. STMicroelectronics NV and its subsidiaries ("ST") reserve the right to make changes, corrections, modifications or improvements, to this document, and the products and services described herein at any time, without notice.

All ST products are sold pursuant to ST's terms and conditions of sale.

Purchasers are solely responsible for the choice, selection and use of the ST products and services described herein, and ST assumes no liability whatsoever relating to the choice, selection or use of the ST products and services described herein.

No license, express or implied, by estoppel or otherwise, to any intellectual property rights is granted under this document. If any part of this document refers to any third party products or services it shall not be deemed a license grant by ST for the use of such third party products or services, or any intellectual property contained therein or considered as a warranty covering the use in any manner whatsoever of such third party products or services or any intellectual property contained therein.

**UNLESS OTHERWISE SET FORTH IN ST'S TERMS AND CONDITIONS OF SALE ST DISCLAIMS ANY EXPRESS OR IMPLIED WARRANTY WITH RESPECT TO THE USE AND/OR SALE OF ST PRODUCTS INCLUDING WITHOUT LIMITATION IMPLIED WARRANTIES OF MERCHANTABILITY, FITNESS FOR A PARTICULAR PURPOSE (AND THEIR EQUIVALENTS UNDER THE LAWS OF ANY JURISDICTION), OR INFRINGEMENT OF ANY PATENT, COPYRIGHT OR OTHER INTELLECTUAL PROPERTY RIGHT.**

**UNLESS EXPRESSLY APPROVED IN WRITING BY AN AUTHORIZED ST REPRESENTATIVE, ST PRODUCTS ARE NOT RECOMMENDED, AUTHORIZED OR WARRANTED FOR USE IN MILITARY, AIR CRAFT, SPACE, LIFE SAVING, OR LIFE SUSTAINING APPLICATIONS, NOR IN PRODUCTS OR SYSTEMS WHERE FAILURE OR MALFUNCTION MAY RESULT IN PERSONAL INJURY, DEATH, OR SEVERE PROPERTY OR ENVIRONMENTAL DAMAGE. ST PRODUCTS WHICH ARE NOT SPECIFIED AS "AUTOMOTIVE GRADE" MAY ONLY BE USED IN AUTOMOTIVE APPLICATIONS AT USER'S OWN RISK.**

Resale of ST products with provisions different from the statements and/or technical features set forth in this document shall immediately void any warranty granted by ST for the ST product or service described herein and shall not create or extend in any manner whatsoever, any liability of ST.

ST and the ST logo are trademarks or registered trademarks of ST in various countries.

Information in this document supersedes and replaces all information previously supplied.

The ST logo is a registered trademark of STMicroelectronics. All other names are the property of their respective owners.

© 2011 STMicroelectronics - All rights reserved

STMicroelectronics group of companies

Australia - Belgium - Brazil - Canada - China - Czech Republic - Finland - France - Germany - Hong Kong - India - Israel - Italy - Japan - Malaysia - Malta - Morocco - Philippines - Singapore - Spain - Sweden - Switzerland - United Kingdom - United States of America

[www.st.com](http://www.st.com)