

LP124/LP2902/LP324 Micropower Quad Operational Amplifier

General Description

The LP124 series consists of four independent, high gain internally compensated micropower operational amplifiers. These amplifiers are specially suited for operation in battery systems while maintaining good input specifications, and extremely low supply current drain. In addition, the LP124 has an input common mode range, and output source range which includes ground, making it ideal in single supply applications.

These amplifiers are ideal in applications which include portable instrumentation, battery backup equipment, and other circuits which require good DC performance and low supply current.

Features

- Low supply current 125 μ A (max)
- Low offset voltage 2 mV (max)
- Low input bias current 4 nA (max)
- Input common mode to GND
- Interfaces to CMOS logic
- Wide supply range $3V < V^+ < 32V$
- Small Outline Package available
- Pin-for-pin compatible with LM124

Connection Diagram

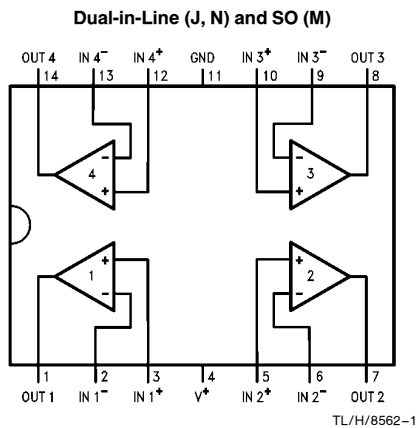

Order Number LP124J or LP324J
See NS Package Number J14A

Order Number LP324M or LP2902M
See NS Package Number M14A

Order Number LP324N or LP2902N
See NS Package Number N14A

Simplified Schematic

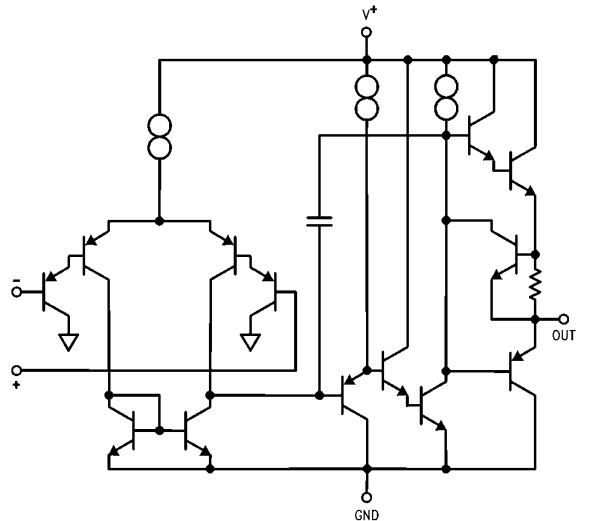

Absolute Maximum Ratings

If Military/Aerospace specified devices are required, please contact the National Semiconductor Sales Office/Distributors for availability and specifications.

Supply Voltage	32V or ± 16V
LP2902	26V or ± 13V
Differential Input Voltage	32V
LP2902	26V
Input Voltage (Note 1)	-0.3V to 32V
LP2902	-0.3V to 26V
Output Short-Circuit to GND (One Amplifier) (Note 2)	Continuous
$V^+ \leq 15V$ and $T_A = 25^\circ C$	
ESD Susceptibility (Note 9)	± 500V

Operating Conditions

	Package		
	J	N	M
Power Dissipation (Note 3)	500 mW	500 mW	500 mW
T_j Max	150°C	150°C	150°C
θ_{ja}	90°C/W	90°C/W	140°C/W
Operating Temp. Range	(Note 4)	(Note 4)	(Note 4)
Storage Temp. Range	-65°C ≤ T ≤ 150°C		
Soldering			
Information (10 sec.)	300°C	260°C	
Vapor Phase (60 sec.)			215°C
Infrared (15 sec.)			220°C

Electrical Characteristics (Note 5)

Symbol	Parameter	Conditions	LP124			LP2902 (Note 8)			LP324			Units Limits
			Typ	Tested Limit (Note 6)	Design Limit (Note 7)	Typ	Tested Limit (Note 6)	Design Limit (Note 7)	Typ	Tested Limit (Note 6)	Design Limit (Note 7)	
V_{os}	Input Offset Voltage		1	2 4	7	2	4	10	2	4	9	mV (Max)
I_b	Input Bias Current		1	4 8	8	2	20	40	2	10	20	nA (Max)
I_{os}	Input Offset Current		0.1	1 2	2	0.5	4	8	0.2	2	4	nA (Max)
A_{vol}	Voltage Gain	$R_L = 10k$ to GND $V^+ = 30V$	100	70 60	60	70	40	30	100	50	40	V/mV (Min)
CMRR	Common Mode Rej. Ratio	$V^+ = 30V$ $0V \leq V_{cm}$ $V_{cm} < V^+ - 1.5$	100	85 80	75	90	80	75	90	80	75	dB (Min)
PSRR	Power Supply Rej. Ratio	$V^+ = 5V$ to 30V	100	85 80	75	90	80	75	90	80	75	dB (Min)
I_s	Supply Current	$R_L = \infty$	85	125 150	200	85	150	250	85	150	250	μA (Max)
V_o	Output Voltage Swing	$I_L = 350 \mu A$ to GND. $V_{cm} = 0V$	3.6	3.4 3.1	$V^+ - 1.9V$	3.6	3.4	$V^+ - 1.9V$	3.6	3.4	$V^+ - 1.9V$	V (Min)
		$I_L = 350 \mu A$ to V^+ $V_{cm} = 0V$	0.7	0.8 1.0	1.0	0.7	0.8	1.0	0.7	0.8	1.0	V (Max)
I_{out} Source	Output Source Current	$V_o = 3V$ $V_{in} (diff) = 1V$	11	9 4	4	10	7	4	10	7	4	mA (Min)
I_{out} Sink	Output Sink Current	$V_o = 1.5V$ $V_{in} (diff) = 1V$	6	5 4	4	5	4	3	5	4	3	mA (Min)
I_{out} Sink	Output Sink Current	$V_o = 1.5V$ $V_{cm} = 0V$	5	3 0.5	1.5	4	2	1	4	2	1	mA (Min)
I_{source}	Output Short to GND	$V_{in} (diff) = 1V$	20	25 35	35	20	25 35	35	20	25 35	35	mA (Max)

Electrical Characteristics (Note 5) (Continued)

Symbol	Parameter	Conditions	LP124			LP2902 (Note 8)			LP324			Units Limits
			Typ	Tested Limit (Note 6)	Design Limit (Note 7)	Typ	Tested Limit (Note 6)	Design Limit (Note 7)	Typ	Tested Limit (Note 6)	Design Limit (Note 7)	
I_{sink}	Output Short to V^+	$V_{in} (diff) = 1V$	15	30 40	45	15	30	45	15	30	45	mA (Max)
V_{os} Drift			7			10			10			$\mu V/C^\circ$
I_{os} Drift			5			10			10			pA/C $^\circ$
GBW	Gain Bandwidth Product		100			100			100			KHz
S_r	Slew Rate		50			50			50			V/mS

Note 1: The input voltage is not allowed to go more than $-0.3V$ below V^- (GND) as this will turn on a parasitic transistor causing large currents to flow through the device.

Note 2: Short circuits from the output to GND can cause excessive heating and eventual destruction. The maximum sourcing output current is approximately 30 mA independent of the magnitude of V^+ . At values of supply voltage in excess of $15 V_{DC}$, continuous short-circuit to GND can exceed the power dissipation ratings (particularly at elevated temperatures) and cause eventual destruction. Destructive dissipation can result from simultaneous shorts on all amplifiers.

Note 3: For operation at elevated temperatures, these devices must be derated based on a thermal resistance of θ_{ja} and T_j max. $T_j = T_A + \theta_{ja}P_D$.

Note 4: The LP124 may be operated from $-55^\circ C \leq T_A \leq +125^\circ C$. The LP2902 may be operated from $-40^\circ C \leq T_A \leq +85^\circ C$, and the LP324 may be operated from $0^\circ C \leq T_A \leq +70^\circ C$.

Note 5: Boldface numbers apply at temperature extremes. All other numbers apply only at $T_A = T_j = 25^\circ C$, $V^+ = 5V$, $V_{cm} = V/2$, and $R_L = 100k$ connected to GND unless otherwise specified.

Note 6: Guaranteed and 100% production tested.

Note 7: Guaranteed (but not 100% production tested) over the operating supply voltage range (3.0V to 32V for the LP124, LP324, and 3.0V to 26V for the LP2902), and the common mode range ($0V$ to $V^+ - 1.5V$), unless otherwise specified. These limits are not used to calculate outgoing quality levels.

Note 8: The LP2902 operating supply range is 3V to 26V, and is not tested above 26V.

Note 9: The test circuit used consists of the human body model of 100 pF in series with 1500 Ω .

Typical Performance Curves

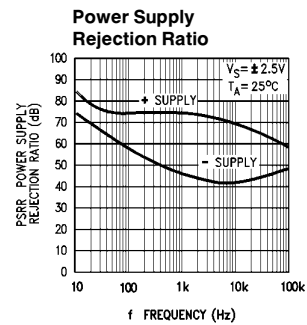
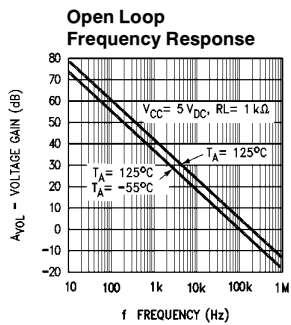
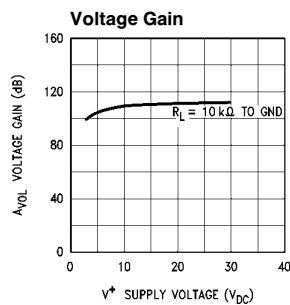
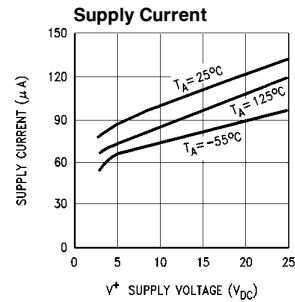
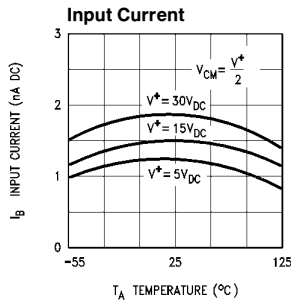
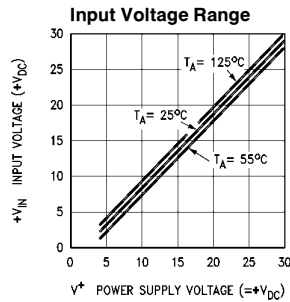

TL/H/8562-18

Typical Performance Curves (Continued)

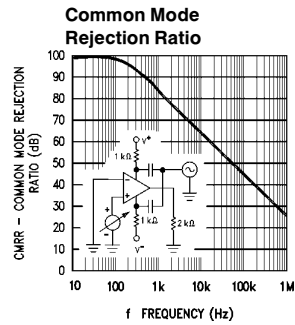
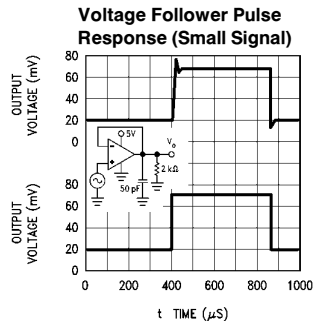
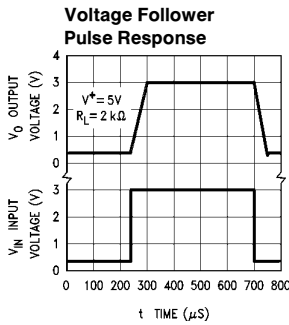

TL/H/8562-20

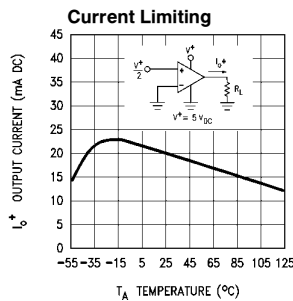
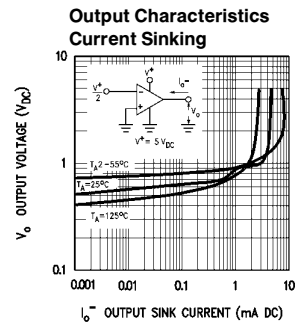
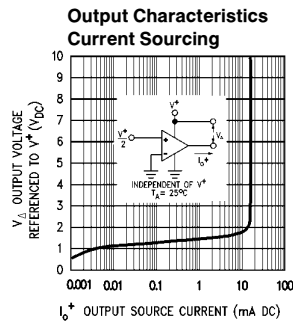
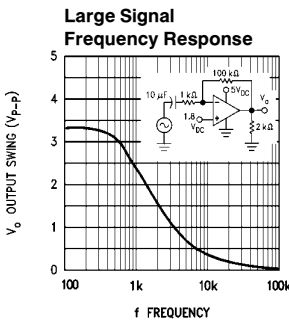

TL/H/8562-19

Application Hints

The LP124 series is a micro-power pin-for-pin equivalent to the LM124 op amps. Power supply current, input bias current, and input offset current have all been reduced by a factor of 10 over the LM124. Like its predecessor, the LP124 series op amps can operate on single supply, have true-differential inputs, and remain in the linear mode with an input common-mode voltage of 0 V_{DC} .

The pinouts of the package have been designed to simplify PC board layouts. Inverting inputs are adjacent to outputs for all of the amplifiers and the outputs have also been placed at the corners of the package (pins 1, 7, 8, and 14). Precautions should be taken to insure that the power supply for the integrated circuit never becomes reversed in polarity or the unit is not inadvertently installed backwards in the

test socket as an unlimited current surge through the resulting forward diode within the IC could destroy the unit.

Large differential input voltages can be easily accommodated and, as input differential voltage protection diodes are not needed, no large input currents result from large differential input voltages. The differential input voltage may be larger than V^+ without damaging the device. Protection should be provided to prevent the input voltages from going negative more than $-0.3 V_{DC}$ (at $25^\circ C$). An input clamp diode with a resistor to the IC input terminal can be used.

The amplifiers have a class B output stage which allows the amplifiers to both source and sink output currents. In applications where crossover distortion is undesirable, a resistor

Application Hints (Continued)

should be used from the output of the amplifier to ground. The resistor biases the output into class A operation.

The LP124 has improved stability margin for driving capacitive loads. No special precautions are needed to drive loads in the 50 pF to 1000 pF range. It should be noted however that since the power supply current has been reduced by a factor of 10, so also has the slew rate and gain bandwidth product. This reduction can cause reduced performance in AC applications where the LM124 is being replaced by an LP124. Such situations usually occur when the LM124 has been operated near its power bandwidth.

Output short circuits either to ground or to the positive power supply should be of short time duration. Units can be destroyed, not as a result of the short circuit current causing metal fusing, but rather due to the large increase in IC chip dissipation which will cause eventual failure due to excessive junction temperatures. For example: If all four amplifiers were simultaneously shorted to ground on a 10V supply the junction temperature would rise by 110°C.

Exceeding the negative common-mode limit on either input will cause a reversal of phase to the output and force

the amplifier to the corresponding high or low state. Exceeding the negative common-mode limit on both inputs will force the amplifier output to a high state. Exceeding the positive common-mode limit on a single input will not change the phase of the output. However, if both inputs exceed the limit, the output of the amplifier will be forced to a low state. In neither case does a latch occur since returning the input within the common mode range puts the input stage and thus the amplifier in a normal operating mode.

The circuits presented in the section on typical applications emphasize operation on only a single power supply voltage. If complementary power supplies are available, all of the standard op amp circuits can be used. In general, introducing a pseudo-ground (a bias voltage reference to $V^+ / 2$) will allow operation above and below this value in single power supply systems. Many application circuits are shown which take advantage of the wide input common-mode voltage range which includes ground. In most cases, input biasing is not required and input voltages which range to ground can easily be accommodated.

Driving CMOS

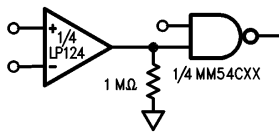

TL/H/8562-3

Comparator with Hysteresis

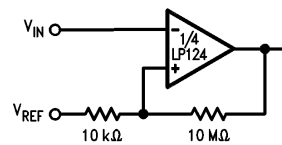

TL/H/8562-6

Non-Inverting Amplifier

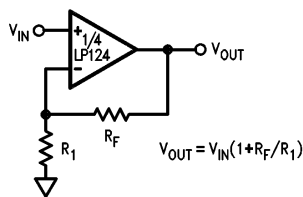

TL/H/8562-4

Adder/Subtractor

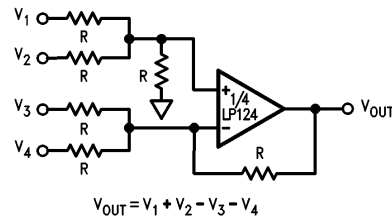

TL/H/8562-7

Unity Gain Buffer

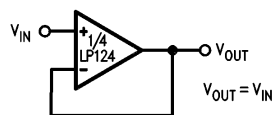

TL/H/8562-5

Positive Integrator

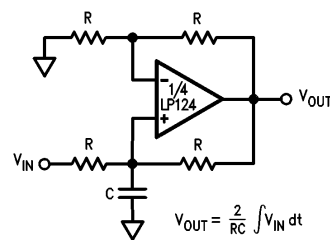

TL/H/8562-8

Application Hints (Continued)

Differential Integrator

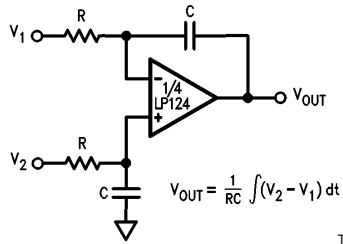

TL/H/8562-9

Howland Current Pump

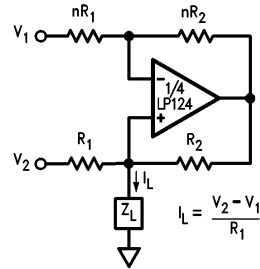

TL/H/8562-10

Bridge Current Amplifier

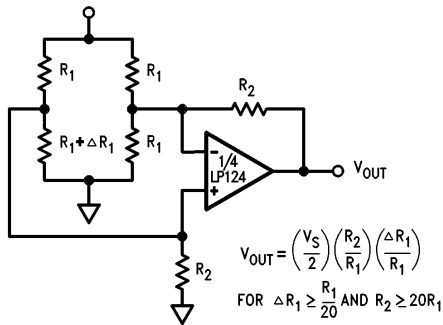

TL/H/8562-11

μ Power Current Source

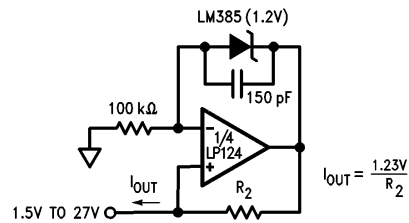

TL/H/8562-12

Lowpass Filter

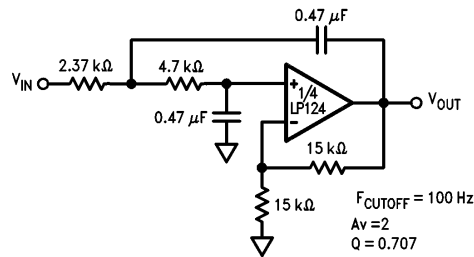

TL/H/8562-13

1 kHz Bandpass Active Filter

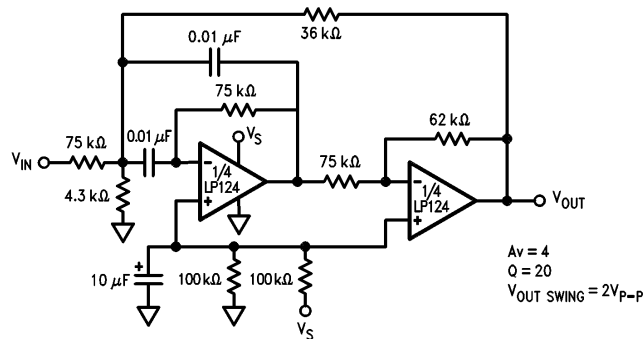

TL/H/8562-14

Application Hints (Continued)

Band-Reject Filter

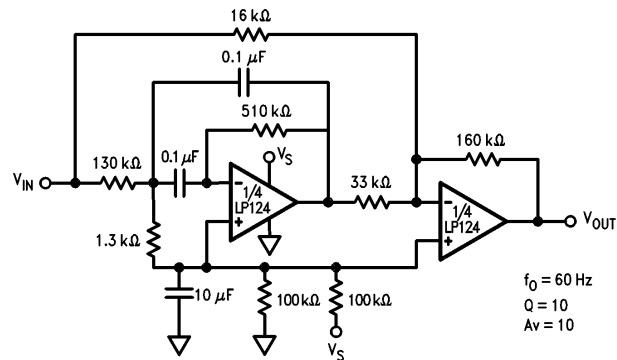

TL/H/8562-15

Pulse Generator

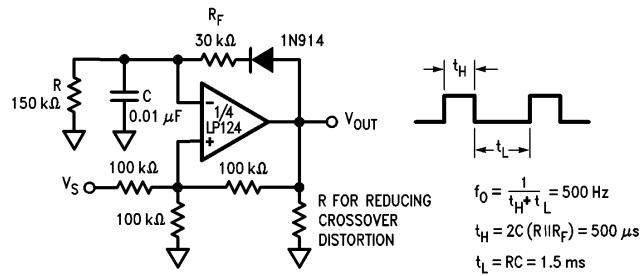

TL/H/8562-16

Window Comparator

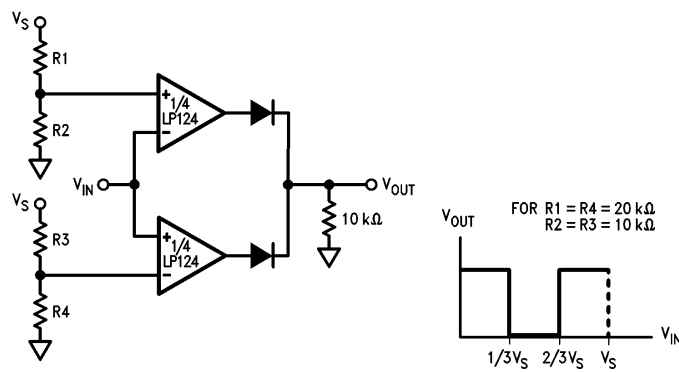

TL/H/8562-17

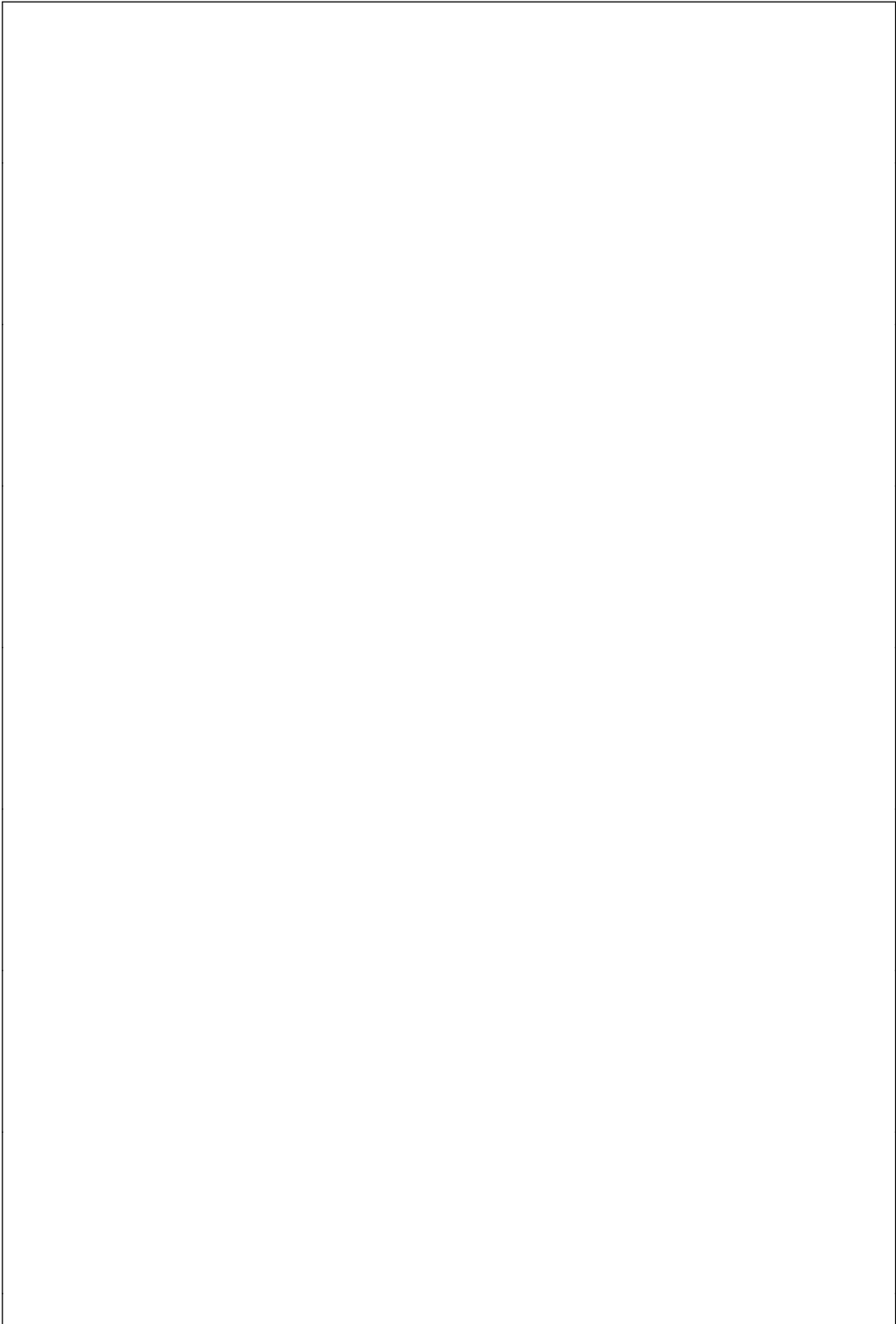

Physical Dimensions inches (millimeters) unless otherwise noted

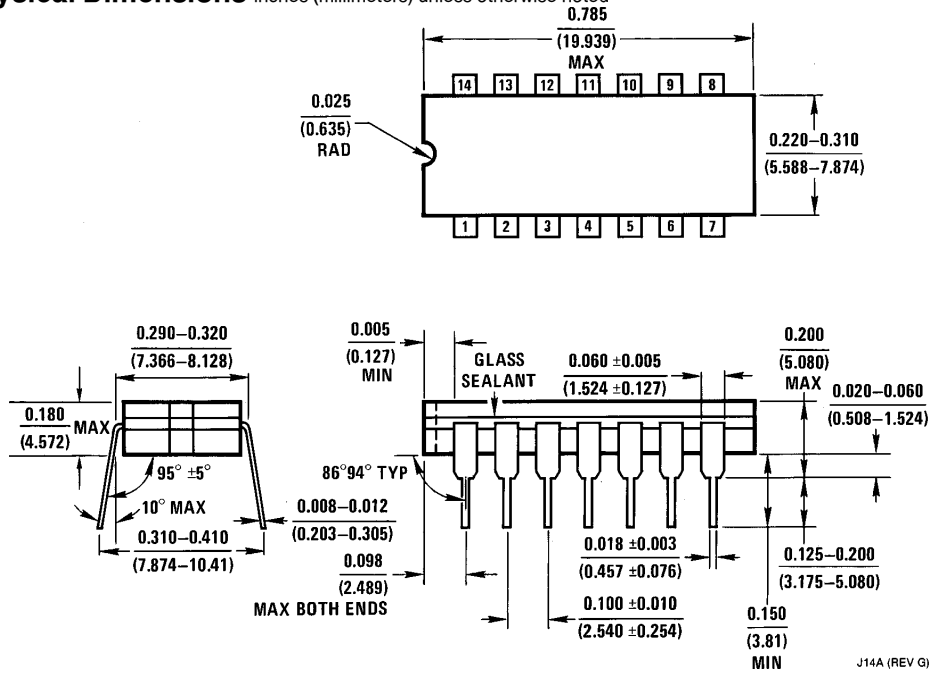

Ceramic Dual-in-Line Package (J)
Order Number LP124J or LP324J
NS Package Number J14A

J14A (REV G)

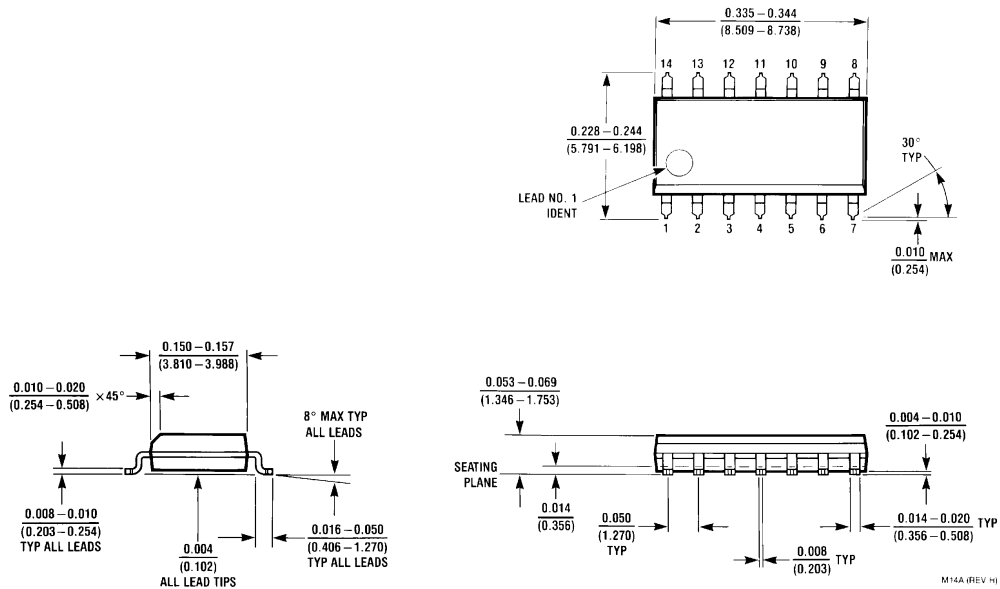

S.O. Package (M)
Order Number LP324M or LP2902M
NS Package Number M14A

M14A (REV H)

Physical Dimensions inches (millimeters) unless otherwise noted (Continued)

Lit. # 108468

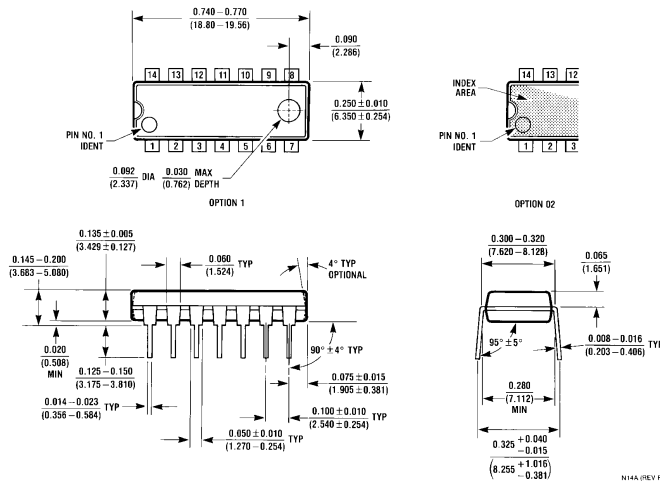

Dual-in-Line Package (N)
Order Number LP324N or LP2902N
NS Package Number N14A

LIFE SUPPORT POLICY

NATIONAL'S PRODUCTS ARE NOT AUTHORIZED FOR USE AS CRITICAL COMPONENTS IN LIFE SUPPORT DEVICES OR SYSTEMS WITHOUT THE EXPRESS WRITTEN APPROVAL OF THE PRESIDENT OF NATIONAL SEMICONDUCTOR CORPORATION. As used herein:

1. Life support devices or systems are devices or systems which, (a) are intended for surgical implant into the body, or (b) support or sustain life, and whose failure to perform, when properly used in accordance with instructions for use provided in the labeling, can be reasonably expected to result in a significant injury to the user.
2. A critical component is any component of a life support device or system whose failure to perform can be reasonably expected to cause the failure of the life support device or system, or to affect its safety or effectiveness.

 <p>National Semiconductor Corporation 1111 West Bardin Road Arlington, TX 76017 Tel: 1(800) 272-9959 Fax: 1(800) 737-7018 http://www.national.com</p>	<p>National Semiconductor Europe Fax: +49 (0) 180-530 85 86 Email: europe.support@nsc.com Deutsch Tel: +49 (0) 180-530 85 85 English Tel: +49 (0) 180-532 78 32 Français Tel: +49 (0) 180-532 93 58 Italiano Tel: +49 (0) 180-534 16 80</p>	<p>National Semiconductor Hong Kong Ltd. 19th Floor, Straight Block, Ocean Centre, 5 Canton Rd. Tsimshatsui, Kowloon Hong Kong Tel: (852) 2737-1600 Fax: (852) 2736-9960</p>	<p>National Semiconductor Japan Ltd. Tel: 81-043-299-2308 Fax: 81-043-299-2408</p>
---	--	---	---

National does not assume any responsibility for use of any circuitry described, no circuit patent licenses are implied and National reserves the right at any time without notice to change said circuitry and specifications.