

LMZ1420xEXT / LMZ1200xEXT Evaluation Board

National Semiconductor
Application Note 2084
Alan Martin
August 16, 2010



Introduction

The LMZ1420xEXT and LMZ1200xEXT SIMPLE SWITCHER® power modules are easy-to-use DC-DC solution capable of driving up to a 3A load with exceptional power conversion efficiency, output voltage accuracy, line and load regulation. They are available in an innovative package that enhances thermal performance and allows for hand or machine soldering.

The LMZ14203EXT/2EXT/1EXT can accept an input voltage rail between 6V and 42V and the LMZ12003EXT/2EXT/1EXT can accept an input voltage rail between 4.5V and 20V. The devices can deliver an adjustable and highly accurate output voltage as low as 0.8V and as high as 6V. The control structure is constant on-time with input voltage feed forward. This creates a nearly constant switching frequency across the input voltage range. The control loop operates well with low ESR output capacitors such as ceramics. An output feed-forward capacitor across the upper feedback resistor trims for optimum transient response. The precision enable input allows for programmable UVLO of the input supply. The external soft-start capacitor facilitates controlled startup output rise time. The LMZ1420xEXT and LMZ1200xEXT family is a reliable and robust solution with the following features: lossless cycle-by-cycle valley current limit to protect for over current or short-circuit fault, thermal shutdown, input under-voltage lock-out, and will start up into a pre-biased output. The LMZ1420xEXT and LMZ1200xEXT families are shock and vibration certified and rated for operation down to -55°C .

Board Specifications

- LMZ1420xEXT $V_{IN} = 6\text{V to }42\text{V}$
- LMZ1420xEXT enable UVLO = 8V
- LMZ1420xEXT $V_{OUT} = 3.3\text{V}$
- LMZ1200xEXT $V_{IN} = 4.5\text{V to }20\text{V}$
- LMZ1200xEXT enable UVLO = 4.5V
- LMZ1200xEXT $V_{OUT} = 1.8\text{V}$
- Operates at full load up to 80°C ambient at 12V input
- $\theta_{JA} = 20^{\circ}\text{C / W}$, $\theta_{JC} = 1.9^{\circ}\text{C / W}$
- Designed on four layers, all four layers are 1 oz. copper weight
- The two internal ground planes are identical
- Measures 1.705 in. x 3.03 in. (4.33 cm x 7.7cm) and is 62mil (.062") thick of FR4 laminate material

For additional circuit modifications refer to the Design Consideration section of the LMZ1420xEXT or LMZ1200xEXT data sheet. For negative output voltage connections see AN-2027.

Additional Footprints

Additional component mounting pads are available to experiment with alternative C_{in} and C_{out} combinations or a zener clamp on the enable input. See Figure 6 for corresponding schematic locations.

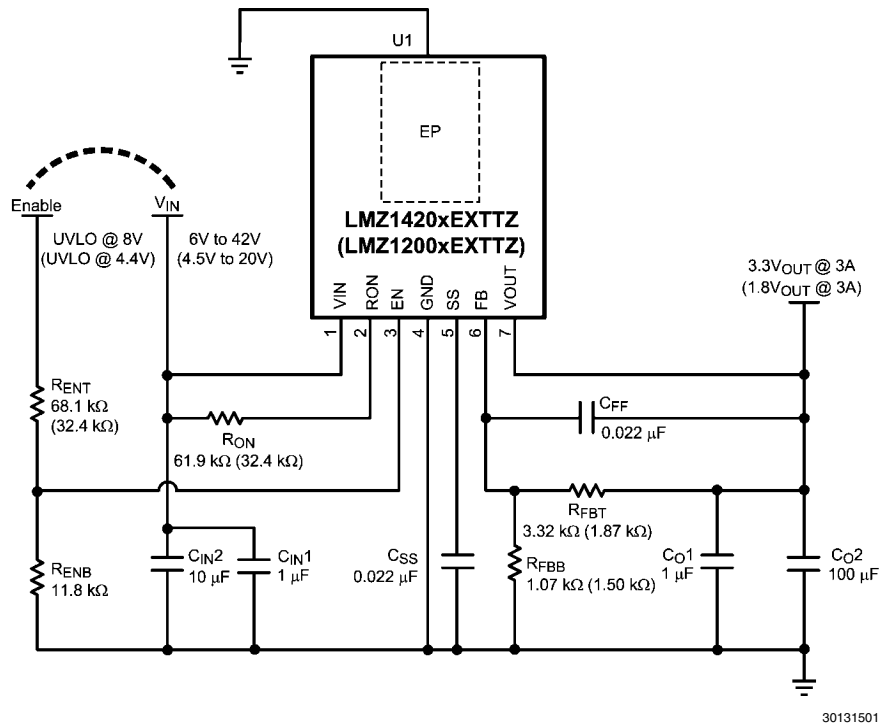

FIGURE 1. Evaluation Board Schematic
(LMZ1200xEXT 1.8V application values shown in parentheses)

30131501

TABLE 1. LMZ1420xEXT Bill of Materials, $V_{IN} = 8V$ to $42V$, $V_{OUT} = 3.3V$, $I_{OUT(MAX)} = 3A / 2A / 1A$

Designator	Description	Case Size	Manufacturer	Manufacturer P/N	Quantity
U1	SIMPLE SWITCHER®	TO-PMOD-7	National Semiconductor	LMZ14203EXTTZ or LMZ14202EXTTZ or LMZ14201EXTTZ	1
C_{IN4}, C_{O1}	1 μF , X7R, 50V	1206	Taiyo Yuden	UMK316B7105KL-T	2
C_{IN2}	10 μF , X5R, 50V	1210	Taiyo Yuden	UMK325BJ106MM-T	1
C_{O2}	100 μF , X5R, 6.3V	1210	Taiyo Yuden	JMK325BJ107MM-T	1
C_{SS}, C_{FF}	0.022 μF , X7R, 100V	0805	AVX	08051C223JAT2A	2
R_{ENB}	11.8k	0805	Panasonic	ERJ-6ENF1182V	1
R_{ENT}	68.1 k Ω	0805	Panasonic	ERJ-6ENF6812V	1
R_{FBT}	3.32 k Ω	0805	Vishay-Dale	CRCW08053K32FKEA	1
R_{FBB}	1.07 k Ω	0805	Panasonic	CRCW080534K8FKEA	1
R_{ON}	61.9 k Ω	0805	Panasonic	ERJ-6ENF6192V	1

TABLE 2. LMZ1200xEXT Bill of Materials, $V_{IN} = 4.5$ to $20V$, $V_{OUT} = 1.8V$, $I_{OUT(MAX)} = 3A / 2A / 1A$

Designator	Description	Case Size	Manufacturer	Manufacturer P/N	Quantity
U1	SIMPLE SWITCHER®	TO-PMOD-7	National Semiconductor	LMZ12003EXTTZ or LMZ12002EXTTZ or LMZ12001EXTTZ	1
C_{IN4}, C_{O1}	1 μF , X7R, 50V	1206	Taiyo Yuden	UMK316B7105KL-T	2
C_{IN2}	10 μF , X5R, 50V	1210	Taiyo Yuden	UMK325BJ106MM-T	1
C_{O2}	100 μF , X5R, 6.3V	1210	Taiyo Yuden	JMK325BJ107MM-T	1
C_{SS}, C_{FF}	0.022 μF , X7R, 100V	0805	AVX	08051C223JAT2A	2
R_{ENB}	11.8k	0805	Panasonic	ERJ-6ENF1182V	1
R_{ENT}	32.4K Ω	0805	Panasonic	ERJ-6ENF3242V	1
R_{FBT}	1.87 k Ω	0805	Vishay-Dale	CRCW08051K87FKEA`	1
R_{FBB}	1.50 k Ω	0805	Panasonic	CRCW08051K50FKEA	1
R_{ON}	32.4K Ω	0805	Panasonic	ERJ-6ENF3242V	1

Performance Characteristics

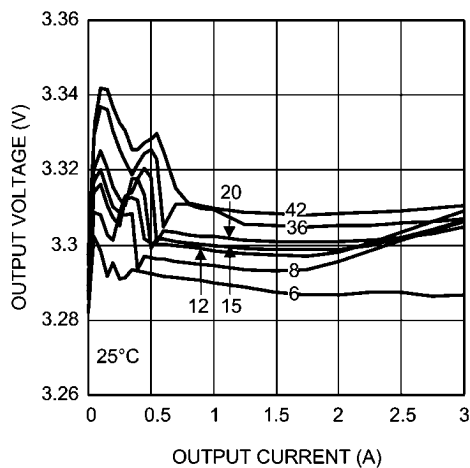
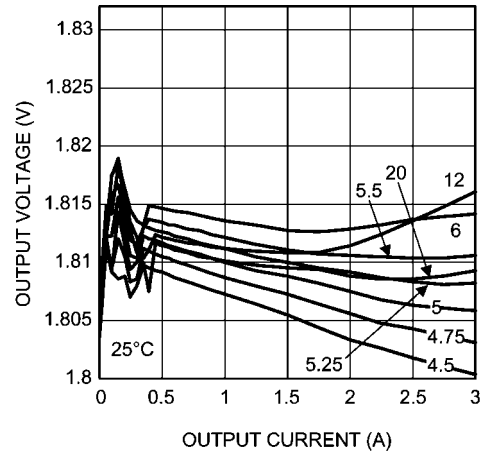
LMZ14203EXT Load and Line Regulation

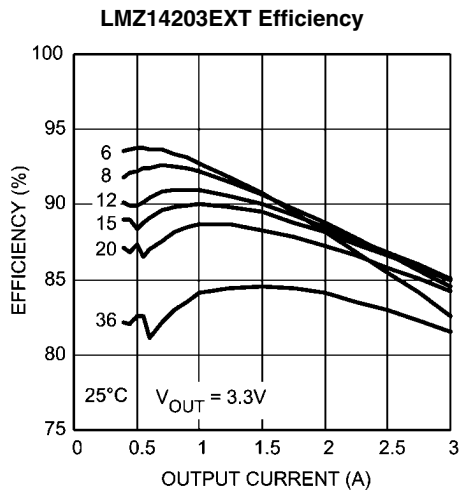
LMZ12003EXT Load and Line Regulation

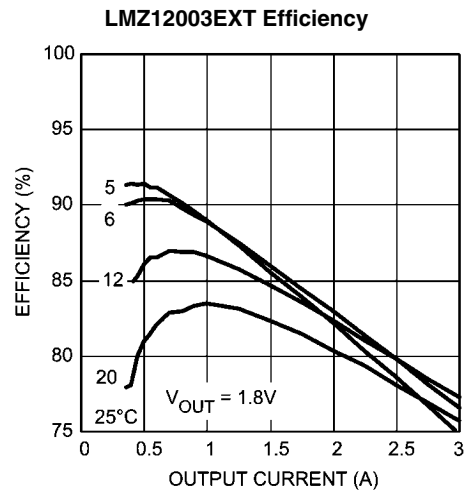

30131502

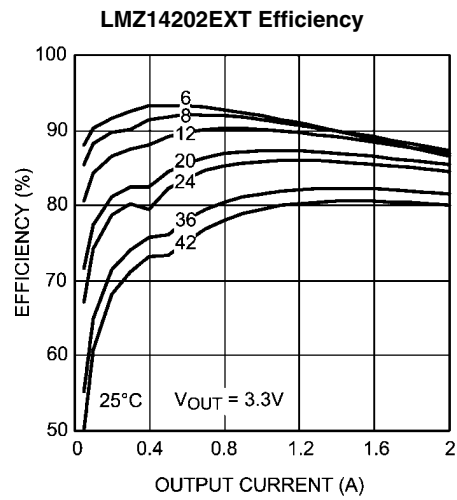

30131503



30131520

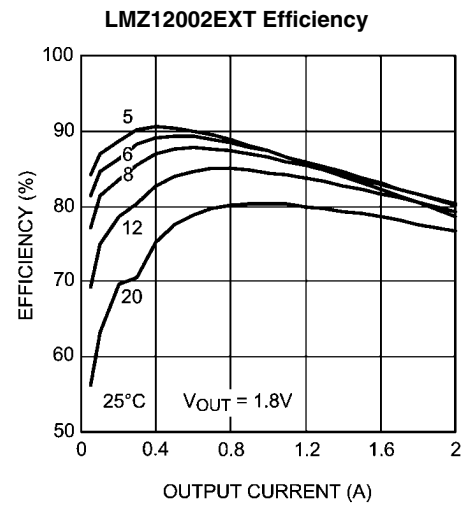

30131521

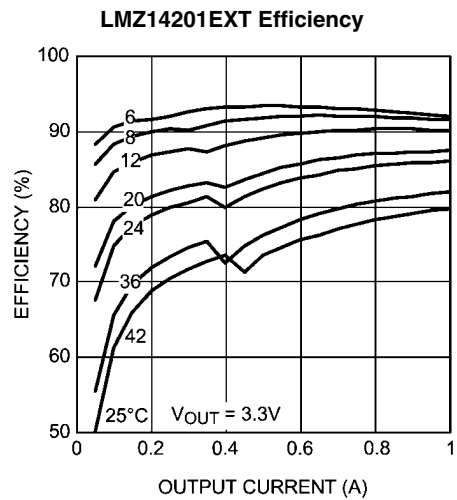

30131522

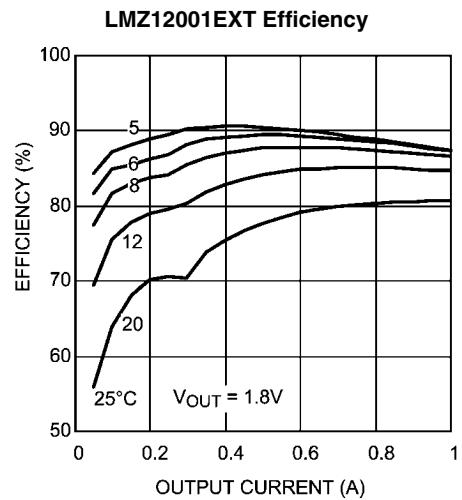

30131523

LMZ14203EXT Thermal Derating

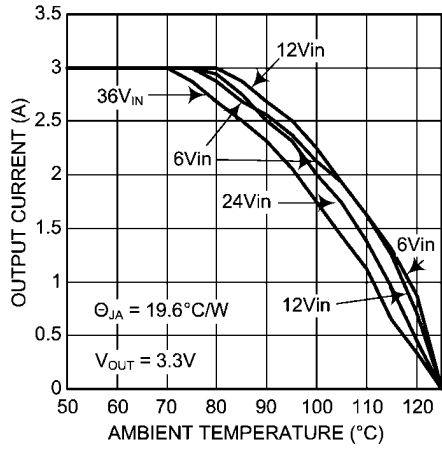

30131515

LMZ12003EXT Thermal Derating

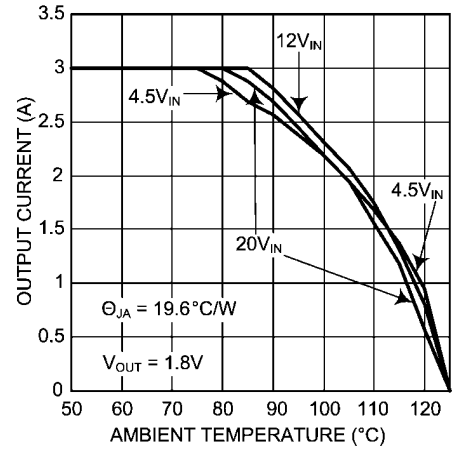

30131516

LMZ14202EXT Thermal Derating

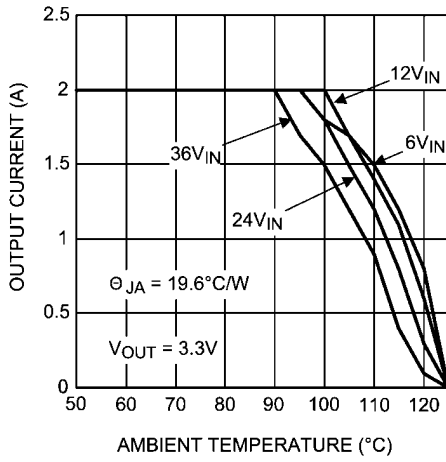

30131524

LMZ12002EXT Thermal Derating

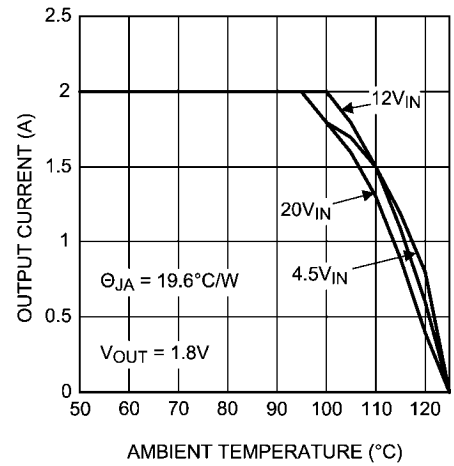

30131525

LMZ14201EXT Thermal Derating

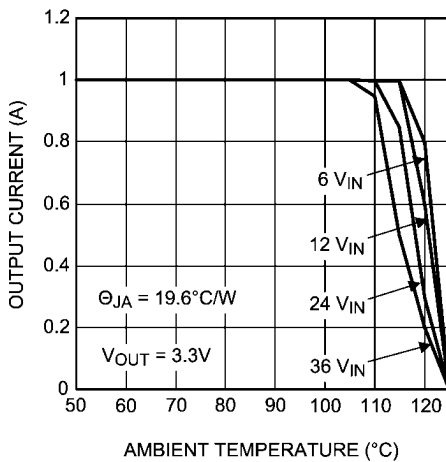

30131526

LMZ12001EXT Thermal Derating

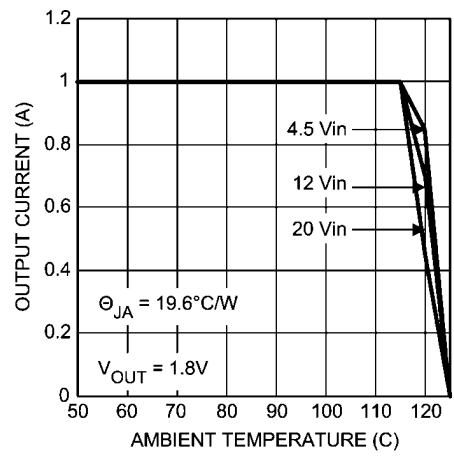

30131527

LMZ14203EXT Current Limit $V_{OUT} = 3.3V$

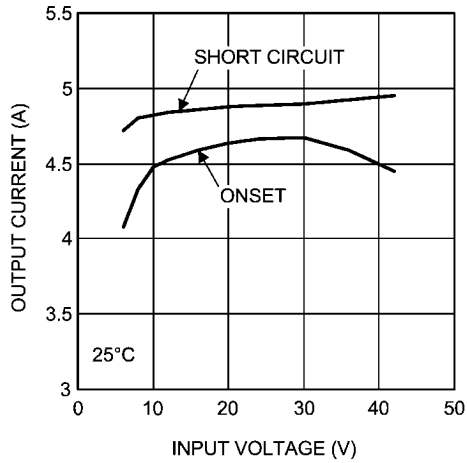

30131528

LMZ12003EXT Current Limit $V_{OUT} = 1.8V$

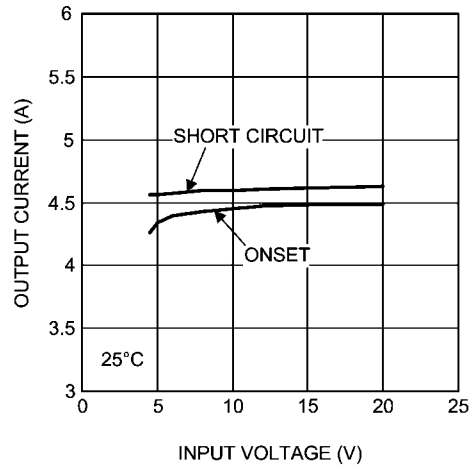

30131529

LMZ14202EXT Current Limit $V_{OUT} = 3.3V$

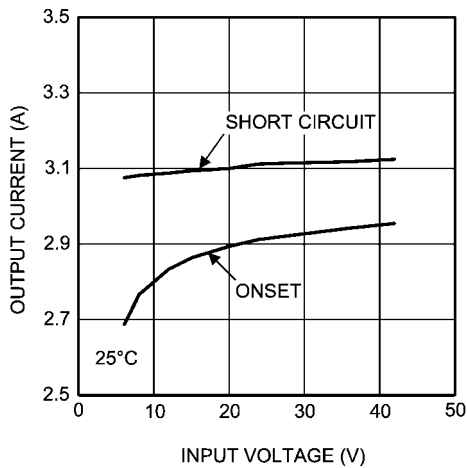

30131530

LMZ12002EXT Current Limit $V_{OUT} = 1.8V$

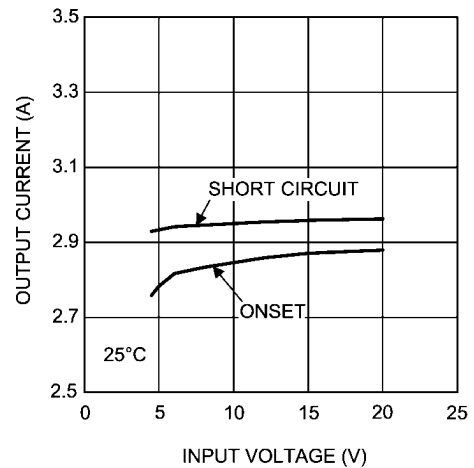

30131531

LMZ14201EXT Current Limit $V_{OUT} = 3.3V$

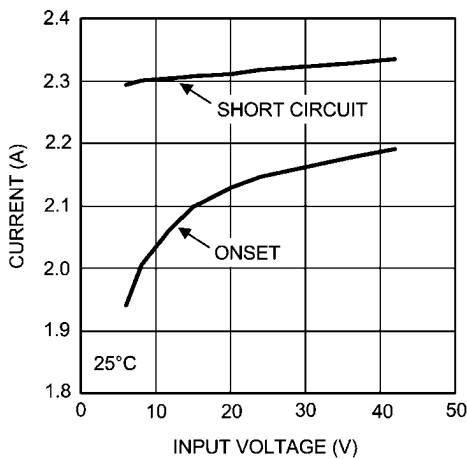

30131532

LMZ12001EXT Current Limit $V_{OUT} = 1.8V$

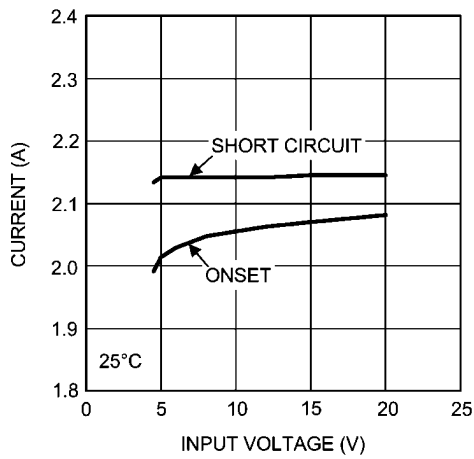

30131533

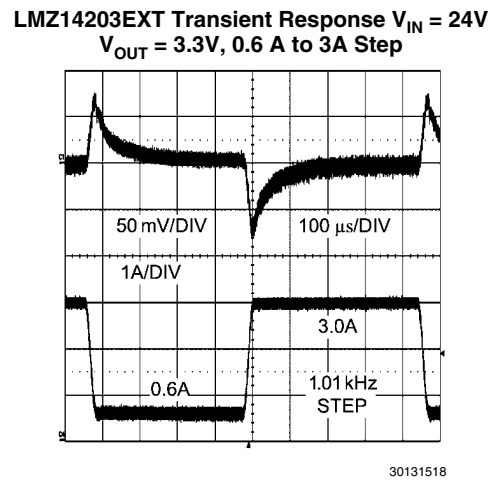
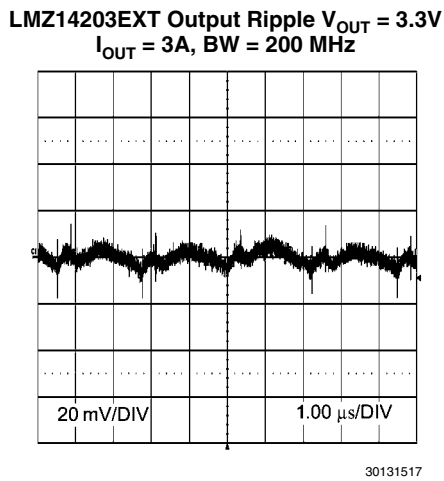
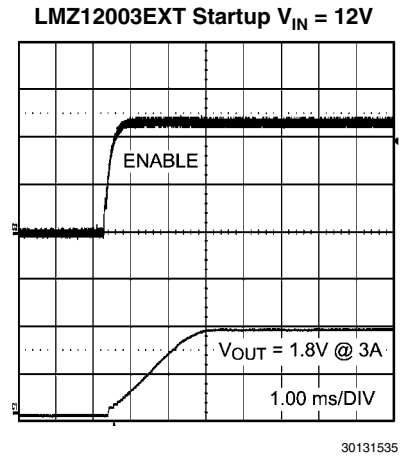
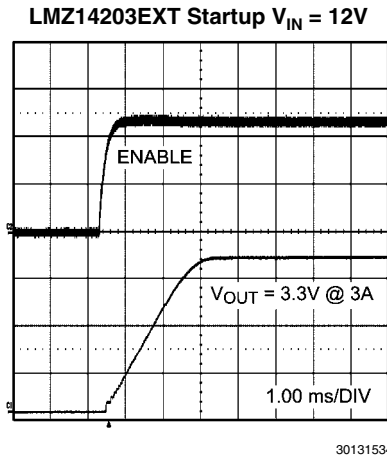

PCB Layout Diagrams

Gerber and CAD files can be download from the LMZ14203EXT product folder.

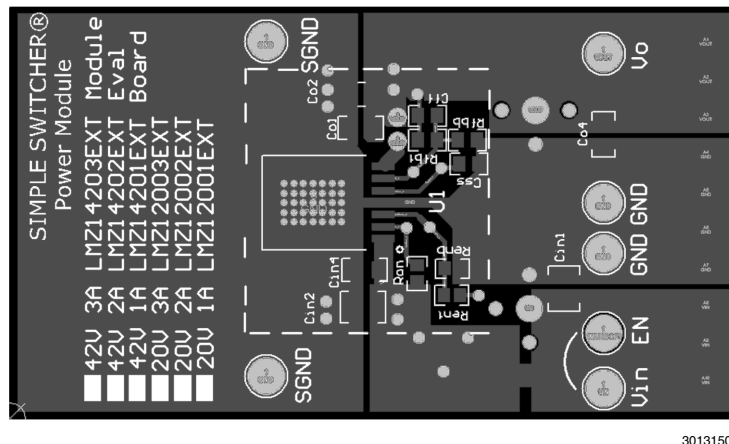
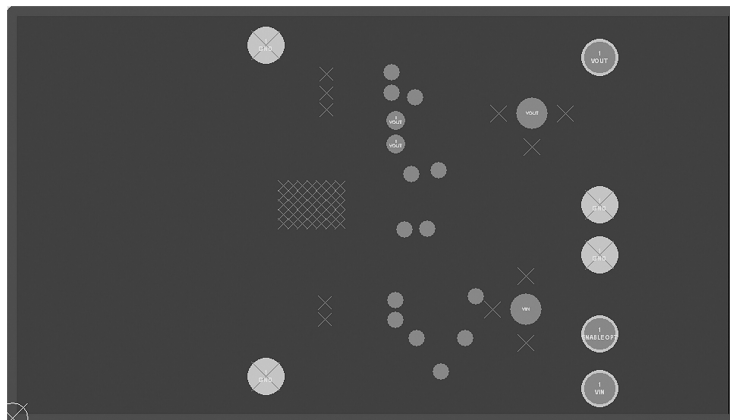
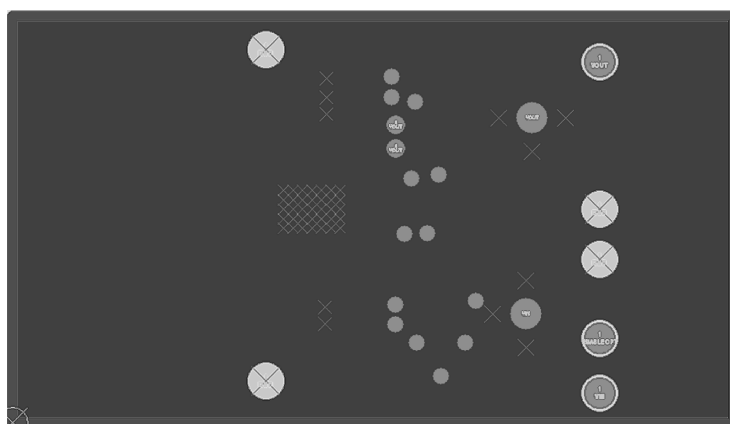

FIGURE 2. Top Layer



30131510

FIGURE 3. Internal Layer I (Ground) Heat Sinking Layer



30131511

FIGURE 4. Internal Layer II (Ground) Heat Sinking Layer

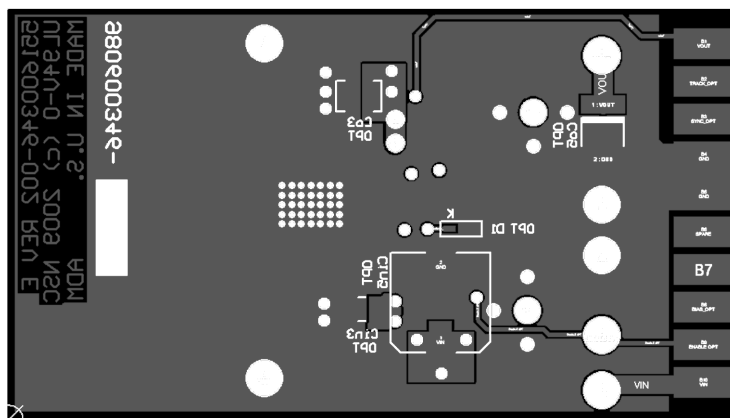

30131512

FIGURE 5. Bottom Layer (Ground and Routing) Heat Sinking Layer

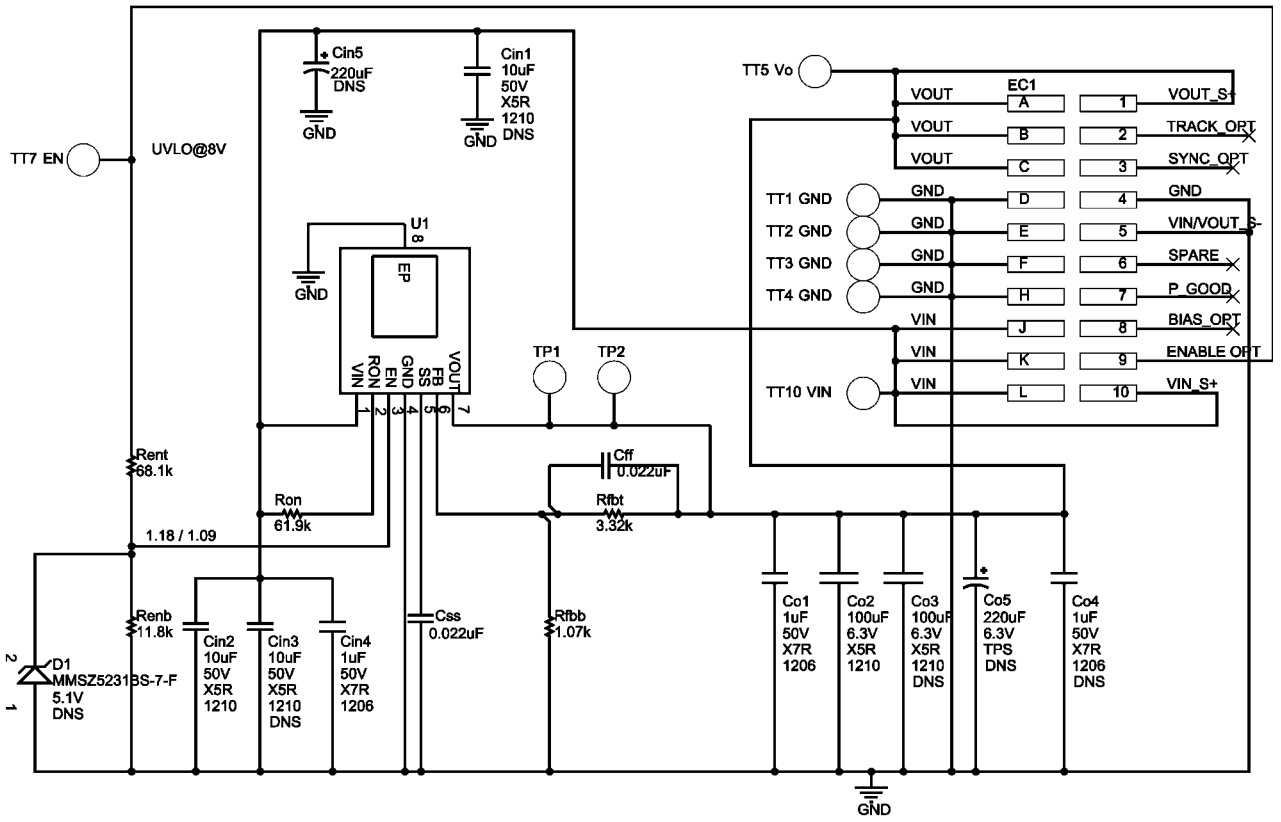

30131513

FIGURE 6. LMZ14203EXT PCB CAD package schematic
 DNS = Component not installed

Notes

AN-2084

Notes

For more National Semiconductor product information and proven design tools, visit the following Web sites at:
www.national.com

Products		Design Support	
Amplifiers	www.national.com/amplifiers	WEBENCH® Tools	www.national.com/webench
Audio	www.national.com/audio	App Notes	www.national.com/appnotes
Clock and Timing	www.national.com/timing	Reference Designs	www.national.com/refdesigns
Data Converters	www.national.com/adc	Samples	www.national.com/samples
Interface	www.national.com/interface	Eval Boards	www.national.com/evalboards
LVDS	www.national.com/lvds	Packaging	www.national.com/packaging
Power Management	www.national.com/power	Green Compliance	www.national.com/quality/green
Switching Regulators	www.national.com/switchers	Distributors	www.national.com/contacts
LDOs	www.national.com/ldo	Quality and Reliability	www.national.com/quality
LED Lighting	www.national.com/led	Feedback/Support	www.national.com/feedback
Voltage References	www.national.com/vref	Design Made Easy	www.national.com/easy
PowerWise® Solutions	www.national.com/powerwise	Applications & Markets	www.national.com/solutions
Serial Digital Interface (SDI)	www.national.com/sdi	Mil/Aero	www.national.com/milaero
Temperature Sensors	www.national.com/tempensors	SolarMagic™	www.national.com/solarmagic
PLL/VCO	www.national.com/wireless	PowerWise® Design University	www.national.com/training

THE CONTENTS OF THIS DOCUMENT ARE PROVIDED IN CONNECTION WITH NATIONAL SEMICONDUCTOR CORPORATION ("NATIONAL") PRODUCTS. NATIONAL MAKES NO REPRESENTATIONS OR WARRANTIES WITH RESPECT TO THE ACCURACY OR COMPLETENESS OF THE CONTENTS OF THIS PUBLICATION AND RESERVES THE RIGHT TO MAKE CHANGES TO SPECIFICATIONS AND PRODUCT DESCRIPTIONS AT ANY TIME WITHOUT NOTICE. NO LICENSE, WHETHER EXPRESS, IMPLIED, ARISING BY ESTOPPEL OR OTHERWISE, TO ANY INTELLECTUAL PROPERTY RIGHTS IS GRANTED BY THIS DOCUMENT.

TESTING AND OTHER QUALITY CONTROLS ARE USED TO THE EXTENT NATIONAL DEEMS NECESSARY TO SUPPORT NATIONAL'S PRODUCT WARRANTY. EXCEPT WHERE MANDATED BY GOVERNMENT REQUIREMENTS, TESTING OF ALL PARAMETERS OF EACH PRODUCT IS NOT NECESSARILY PERFORMED. NATIONAL ASSUMES NO LIABILITY FOR APPLICATIONS ASSISTANCE OR BUYER PRODUCT DESIGN. BUYERS ARE RESPONSIBLE FOR THEIR PRODUCTS AND APPLICATIONS USING NATIONAL COMPONENTS. PRIOR TO USING OR DISTRIBUTING ANY PRODUCTS THAT INCLUDE NATIONAL COMPONENTS, BUYERS SHOULD PROVIDE ADEQUATE DESIGN, TESTING AND OPERATING SAFEGUARDS.

EXCEPT AS PROVIDED IN NATIONAL'S TERMS AND CONDITIONS OF SALE FOR SUCH PRODUCTS, NATIONAL ASSUMES NO LIABILITY WHATSOEVER, AND NATIONAL DISCLAIMS ANY EXPRESS OR IMPLIED WARRANTY RELATING TO THE SALE AND/OR USE OF NATIONAL PRODUCTS INCLUDING LIABILITY OR WARRANTIES RELATING TO FITNESS FOR A PARTICULAR PURPOSE, MERCHANTABILITY, OR INFRINGEMENT OF ANY PATENT, COPYRIGHT OR OTHER INTELLECTUAL PROPERTY RIGHT.

LIFE SUPPORT POLICY

NATIONAL'S PRODUCTS ARE NOT AUTHORIZED FOR USE AS CRITICAL COMPONENTS IN LIFE SUPPORT DEVICES OR SYSTEMS WITHOUT THE EXPRESS PRIOR WRITTEN APPROVAL OF THE CHIEF EXECUTIVE OFFICER AND GENERAL COUNSEL OF NATIONAL SEMICONDUCTOR CORPORATION. As used herein:

Life support devices or systems are devices which (a) are intended for surgical implant into the body, or (b) support or sustain life and whose failure to perform when properly used in accordance with instructions for use provided in the labeling can be reasonably expected to result in a significant injury to the user. A critical component is any component in a life support device or system whose failure to perform can be reasonably expected to cause the failure of the life support device or system or to affect its safety or effectiveness.

National Semiconductor and the National Semiconductor logo are registered trademarks of National Semiconductor Corporation. All other brand or product names may be trademarks or registered trademarks of their respective holders.

Copyright© 2010 National Semiconductor Corporation

For the most current product information visit us at www.national.com



National Semiconductor
Americas Technical
Support Center
 Email: support@nsc.com
 Tel: 1-800-272-9959

National Semiconductor Europe
Technical Support Center
 Email: europe.support@nsc.com

National Semiconductor Asia
Pacific Technical Support Center
 Email: ap.support@nsc.com

National Semiconductor Japan
Technical Support Center
 Email: jpn.feedback@nsc.com