

# LMZ10503

## 3A SIMPLE SWITCHER® Power Module with 5.5V Maximum Input Voltage

Easy to Use 7 Pin Package

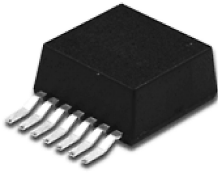

Top View

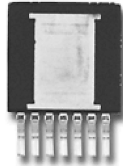

Bottom View

301118a4

**TO-PMOD 7 Pin Package**  
 10.16 x 13.77 x 4.57 mm (0.4 x 0.39 x 0.18 in)  
 $\theta_{JA} = 20^{\circ}\text{C/W}$ ,  $\theta_{JC} = 1.9^{\circ}\text{C/W}$  (Note 3)  
 RoHS Compliant

### Electrical Specifications

- 15W maximum total output power
- Up to 3A output current
- Input voltage range 2.95V to 5.5V
- Output voltage range 0.8V to 5V
- $\pm 1.63\%$  feedback voltage accuracy over temperature
- Efficiency up to 96%

### Key Features

- Integrated shielded inductor
- Flexible startup sequencing using external soft-start, tracking, and precision enable
- Protection against in-rush currents and faults such as input UVLO and output short-circuit
- $-40^{\circ}\text{C}$  to  $+125^{\circ}\text{C}$  junction temperature operating range
- Single exposed pad and standard pinout for easy mounting and manufacturing
- Pin-to-pin compatible with LMZ10504 (4A/20W max) LMZ10505 (5A/25W max)
- Fully enabled for WEBENCH® and Power Designer

### Applications

- Point-of-load conversions from 3.3V and 5V rails
- Space constrained applications
- Extreme temperatures/no air flow environments
- Noise sensitive applications (i.e. transceiver, medical)

### Performance Benefits

- Operates at high ambient temperatures
- High efficiency up to 96% reduces system heat generation
- Low radiated emissions (EMI) complies with EN55022 class B standard (Note 4)
- Low output voltage ripple of 10 mV allows for powering noise-sensitive transceiver and signaling ICs
- Fast transient response for powering FPGAs and ASICs

### System Performance

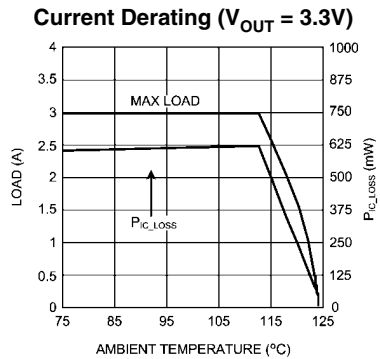

301118a5

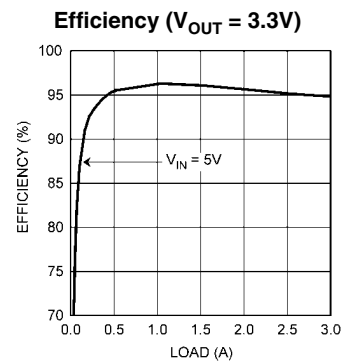

30111871

### Radiated Emissions (EN 55022, Class B)

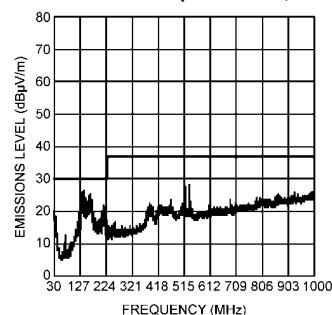

301118a6

**Note 1:** Note 1:  $\theta_{JA}$  measured on a 2.25" x 2.25" (5.8 cm x 5.8 cm) four layer board. Refer to [PCB Layout Diagrams](#) or Evaluation Board Application Note: AN-2022.

**Note 2:** Note 2: EN 55022:2006, +A1:2007, FCC Part 15 Subpart B: 2007. See [Figure 5](#) and layout for information on device under test.

## Typical Application Circuit

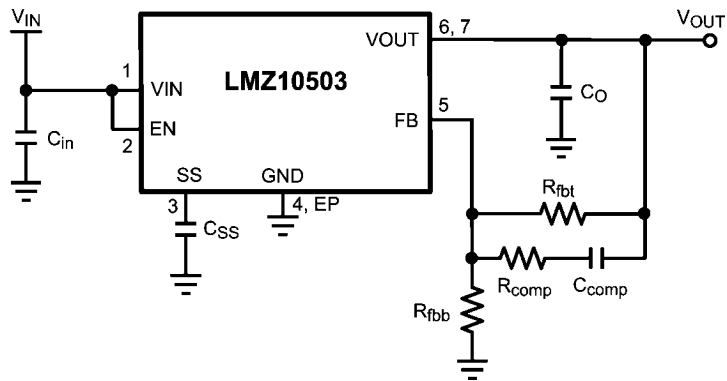

30111801

## Connection Diagram

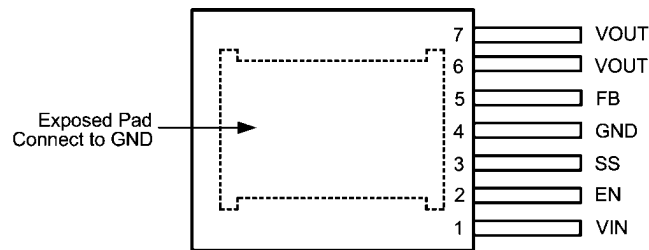

Top View  
7-Lead TO-PMOD

30111872

## Ordering Information

Order Number	Supplied As	Package Type	NSC Package Drawing	Package Marking
LMZ10503TZE-ADJ	45 Units in a Rail	TO-PMOD-7	TZA07A	LMZ10503TZ-ADJ
LMZ10503TZ-ADJ	250 Units in Tape and Reel			
LMZ10503TX-ADJ	500 Units in Tape and Reel			

## Pin Descriptions

Pin Number	Name	Description
1	VIN	Power supply input. A low ESR input capacitance should be located as close as possible to the VIN pin and exposed pad (EP).
2	EN	Active high enable input for the device.
3	SS	Soft-start control pin. An internal 2 $\mu$ A current source charges an external capacitor connected between SS and GND pins to set the output voltage ramp rate during startup. The SS pin can also be used to configure the tracking feature.
4	GND	Power ground and signal ground. Provide a direct connection to the EP. Place the bottom feedback resistor as close as possible to GND and FB pin.
5	FB	Feedback pin. This is the inverting input of the error amplifier used for sensing the output voltage. Keep the copper area of this node small.

Pin Number	Name	Description
6, 7	VOUT	The output terminal of the internal inductor. Connect the output filter capacitor between VOUT pin and EP.
EP	Exposed Pad	Exposed pad is used as a thermal connection to remove heat from the device. Connect this pad to the PC board ground plane in order to reduce thermal resistance value. EP must also provide a direct electrical connection to the input and output capacitors ground terminals. Connect EP to pin 4.

**Absolute Maximum Ratings** (Note 5)

If Military/Aerospace specified devices are required, please contact the National Semiconductor Sales Office/ Distributors for availability and specifications.

V <sub>IN</sub> , V <sub>OUT</sub> , EN, FB, SS to GND	-0.3V to 6.0V
ESD Susceptibility (Note 6)	±2 kV
Power Dissipation	Internally Limited
Junction Temperature	150°C

Storage Temperature Range -65°C to 150°C

For Soldering Specs see:  
www.national.com/ms/MS/MS-SOLDERING.pdf

**Operating Ratings** (Note 5)

V <sub>IN</sub> to GND	2.95V to 5.5V
Junction Temperature (T <sub>J</sub> )	-40°C to 125°C

**Electrical Characteristics** Specifications with standard typeface are for T<sub>J</sub> = 25°C only; limits in bold face type apply over the operating junction temperature range T<sub>J</sub> of -40°C to 125°C. Minimum and maximum limits are guaranteed through test, design, or statistical correlation. Typical values represent the most likely parametric norm at T<sub>J</sub> = 25°C, and are provided for reference purposes only. V<sub>IN</sub> = V<sub>EN</sub> = 3.3V, unless otherwise indicated in the conditions column.

Symbol	Parameter	Conditions	Min (Note 7)	Typ (Note 8)	Max (Note 7)	Units
<b>SYSTEM PARAMETERS</b>						
V <sub>FB</sub>	Total Feedback Voltage Variation Including Line and Load Regulation	V <sub>IN</sub> = 2.95V to 5.5V V <sub>OUT</sub> = 2.5V I <sub>OUT</sub> = 0A to 3A	<b>0.78</b>	0.8	<b>0.82</b>	V
V <sub>FB</sub>	Feedback Voltage Variation	V <sub>IN</sub> = 3.3V, V <sub>OUT</sub> = 2.5V I <sub>OUT</sub> = 0A	<b>0.787</b>	0.8	<b>0.812</b>	V
V <sub>FB</sub>	Feedback Voltage Variation	V <sub>IN</sub> = 3.3V, V <sub>OUT</sub> = 2.5V I <sub>OUT</sub> = 3A	<b>0.785</b>	0.798	<b>0.81</b>	V
V <sub>IN(UVLO)</sub>	Input UVLO Threshold (Measured at VIN pin)	Rising		2.6	<b>2.95</b>	V
		Falling	<b>1.95</b>	2.4		
I <sub>SS</sub>	Soft-Start Current	Charging Current		2		μA
I <sub>Q</sub>	Non-Switching Input Current	V <sub>FB</sub> = 1V		1.7	<b>3</b>	mA
I <sub>SD</sub>	Shut Down Quiescent Current	V <sub>IN</sub> = 5.5V, V <sub>EN</sub> = 0V		260	<b>500</b>	μA
I <sub>OCL</sub>	Output Current Limit (Average Current)	V <sub>OUT</sub> = 2.5V	<b>3.8</b>	5.2	<b>6.7</b>	A
f <sub>FB</sub>	Frequency Fold-back	In current limit		250		kHz
<b>PWM SECTION</b>						
f <sub>sw</sub>	Switching Frequency		<b>750</b>	1000	<b>1160</b>	kHz
D <sub>range</sub>	PWM Duty Cycle Range		<b>0</b>		<b>100</b>	%
<b>ENABLE CONTROL</b>						
V <sub>EN-IH</sub>	EN Pin Rising Threshold			1.23	<b>1.8</b>	V
V <sub>EN-IF</sub>	EN Pin Falling Threshold		<b>0.8</b>	1.06		V
<b>THERMAL CONTROL</b>						
T <sub>SD</sub>	T <sub>J</sub> for Thermal Shutdown			145		°C
T <sub>SD-HYS</sub>	Hysteresis for Thermal Shutdown			10		°C
<b>THERMAL RESISTANCE</b>						
θ <sub>JA</sub>	Junction to Ambient	(Note 3)		20		°C/W
θ <sub>JC</sub>	Junction to Case	No air flow		1.9		°C/W

**Electrical Characteristics** Specifications with standard typeface are for  $T_J = 25^\circ\text{C}$  only; limits in bold face type apply over the operating junction temperature range  $T_J$  of  $-40^\circ\text{C}$  to  $125^\circ\text{C}$ . Minimum and maximum limits are guaranteed through test, design, or statistical correlation. Typical values represent the most likely parametric norm at  $T_J = 25^\circ\text{C}$ , and are provided for reference purposes only.  $V_{IN} = V_{EN} = 3.3\text{V}$ , unless otherwise indicated in the conditions column.

Symbol	Parameter	Conditions	Min (Note 7)	Typ (Note 8)	Max (Note 7)	Units
<b>PERFORMANCE PARAMETERS</b>						
$\Delta V_{OUT}$	Output Voltage Ripple	Refer to <a href="#">Table 3</a> $V_{OUT} = 2.5\text{V}$ Bandwidth Limit = 2 MHz		7		$\text{mV}_{\text{pk-pk}}$
$\Delta V_{OUT}$	Output Voltage Ripple	Refer to <a href="#">Table 5</a> Bandwidth Limit = 20 MHz		5		$\text{mV}_{\text{pk-pk}}$
$\Delta V_{FB} / V_{FB}$	Feedback Voltage Line Regulation	$\Delta V_{IN} = 2.95\text{V}$ to $5.5\text{V}$ $I_{OUT} = 0\text{A}$		0.04		%
$\Delta V_{OUT} / V_{OUT}$	Output Voltage Line Regulation	$\Delta V_{IN} = 2.95\text{V}$ to $5.5\text{V}$ $I_{OUT} = 0\text{A}$ , $V_{OUT} = 2.5\text{V}$		0.04		%
$\Delta V_{FB} / V_{FB}$	Feedback Voltage Load Regulation	$I_{OUT} = 0\text{A}$ to $3\text{A}$		0.25		%
$\Delta V_{OUT} / V_{OUT}$	Output Voltage Load Regulation	$I_{OUT} = 0\text{A}$ to $3\text{A}$ $V_{OUT} = 2.5\text{V}$		0.25		%
<b>Efficiency</b>						
$\eta$	Peak Efficiency (1A) $V_{IN} = 5\text{V}$	$V_{OUT} = 3.3\text{V}$		96.3		%
		$V_{OUT} = 2.5\text{V}$		94.9		
		$V_{OUT} = 1.8\text{V}$		93.3		
		$V_{OUT} = 1.5\text{V}$		92.2		
		$V_{OUT} = 1.2\text{V}$		90.5		
		$V_{OUT} = 0.8\text{V}$		86.9		
$\eta$	Peak Efficiency (1A) $V_{IN} = 3.3\text{V}$	$V_{OUT} = 2.5\text{V}$		95.7		%
		$V_{OUT} = 1.8\text{V}$		94.0		
		$V_{OUT} = 1.5\text{V}$		92.9		
		$V_{OUT} = 1.2\text{V}$		91.3		
		$V_{OUT} = 0.8\text{V}$		87.9		
$\eta$	Full Load Efficiency (3A) $V_{IN} = 5\text{V}$	$V_{OUT} = 3.3\text{V}$		94.8		%
		$V_{OUT} = 2.5\text{V}$		93		
		$V_{OUT} = 1.8\text{V}$		90.8		
		$V_{OUT} = 1.5\text{V}$		89.3		
		$V_{OUT} = 1.2\text{V}$		87.1		
		$V_{OUT} = 0.8\text{V}$		82.3		
$\eta$	Full Load Efficiency (3A) $V_{IN} = 3.3\text{V}$	$V_{OUT} = 2.5\text{V}$		92.4		%
		$V_{OUT} = 1.8\text{V}$		89.8		
		$V_{OUT} = 1.5\text{V}$		88.2		
		$V_{OUT} = 1.2\text{V}$		85.9		
		$V_{OUT} = 0.8\text{V}$		80.8		

**Note 3:**  $\theta_{JA}$  measured on a 2.25" x 2.25" (5.8 cm x 5.8 cm) four layer board, with one ounce copper, thirty six 10mil thermal vias, no air flow, and 1W power dissipation. Refer to [PCB Layout Diagrams](#) or Evaluation Board Application Note: AN-2022.

**Note 4:** EN 55022:2006, +A1:2007, FCC Part 15 Subpart B: 2007. See [Table 9](#) and layout for information on device under test.

**Note 5:** Absolute Maximum Ratings are limits beyond which damage to the device may occur. Operating Ratings are conditions under which operation of the device is intended to be functional. For guaranteed specifications and test conditions, see the Electrical Characteristics.

**Note 6:** The human body model is a 100 pF capacitor discharged through a 1.5 k $\Omega$  resistor into each pin. Test method is per JESD22-A114S.

**Note 7:** Min and Max limits are 100% production tested at an ambient temperature ( $T_A$ ) of  $25^\circ\text{C}$ . Limits over the operating temperature range are guaranteed through correlation using Statistical Quality Control (SQC) methods. Limits are used to calculate National's Average Outgoing Quality Level (AOQL).

**Note 8:** Typical numbers are at  $25^\circ\text{C}$  and represent the most likely parametric norm.

## Typical Performance Characteristics

Unless otherwise specified, the following conditions apply:  $V_{IN} = V_{EN} = 5.0V$ ,  $C_{IN}$  is 47  $\mu F$  10V X5R ceramic capacitor;  $T_{AMBIENT} = 25^{\circ}C$  for efficiency curves and waveforms.

### Load Transient Response

$V_{IN} = 3.3V$ ,  $V_{OUT} = 2.5V$ ,  $I_{OUT} = 0.3A$  to  $2.7A$  to  $0.3A$  step  
20 MHz Bandwidth Limited

Refer to [Table 5](#) for BOM, includes optional components

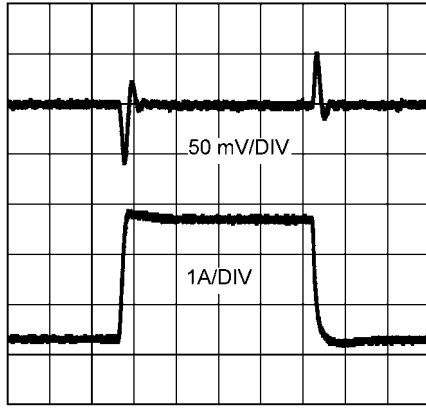

100  $\mu s$ /DIV

30111862

### Load Transient Response

$V_{IN} = 5.0V$ ,  $V_{OUT} = 2.5V$ ,  $I_{OUT} = 0.3A$  to  $2.7A$  to  $0.3A$  step  
20 MHz Bandwidth Limited

Refer to [Table 5](#) for BOM, includes optional components

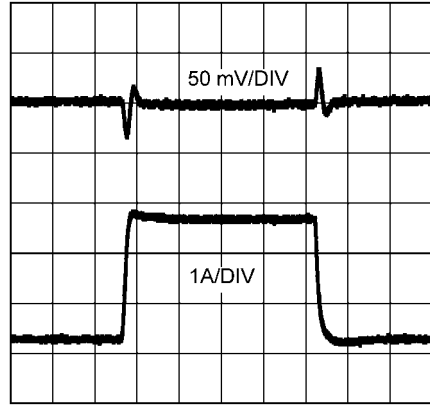

100  $\mu s$ /DIV

30111863

### Output Voltage Ripple

$V_{IN} = 3.3V$ ,  $V_{OUT} = 2.5V$ ,  $I_{OUT} = 3A$ , 20 mV/DIV  
Refer to [Table 5](#) for BOM

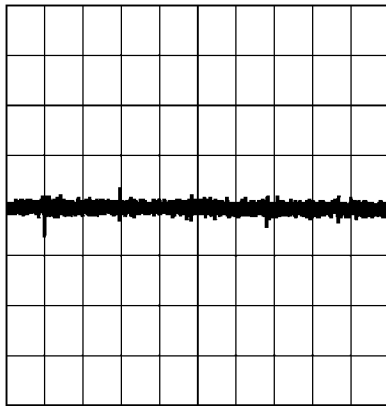

500 ns/DIV

30111864

### Output Voltage Ripple

$V_{IN} = 5.0V$ ,  $V_{OUT} = 2.5V$ ,  $I_{OUT} = 3A$ , 20 mV/DIV  
Refer to [Table 5](#) for BOM

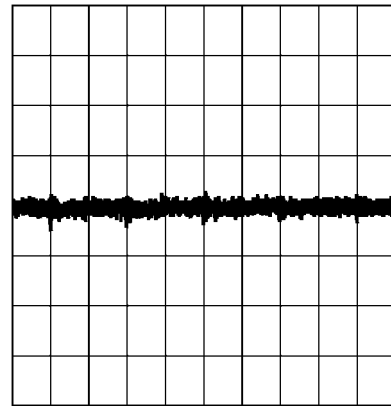

500 ns/DIV

30111865

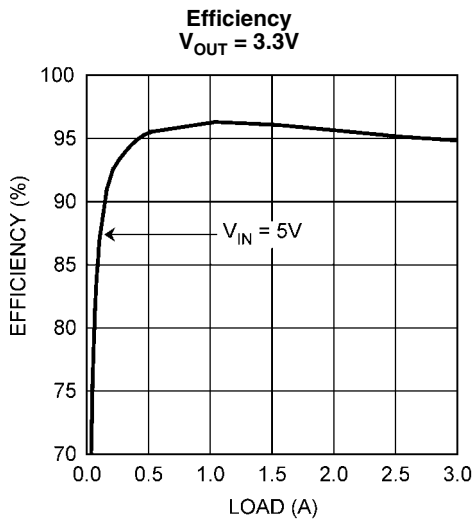

30111871

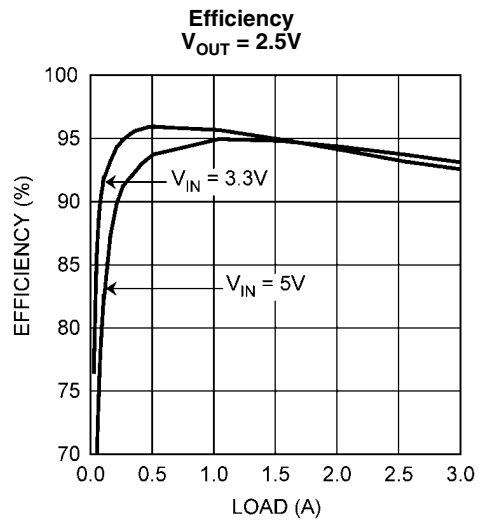

30111870

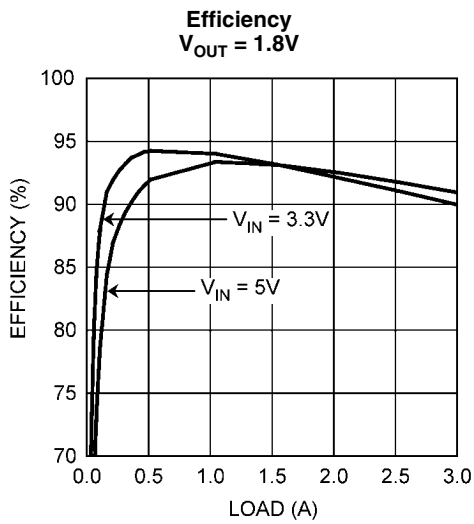

30111869

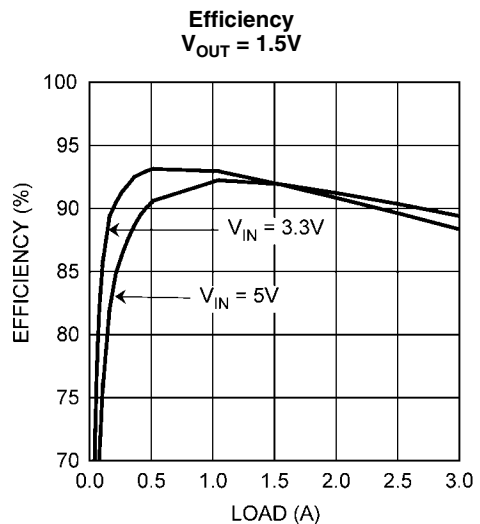

301118a0

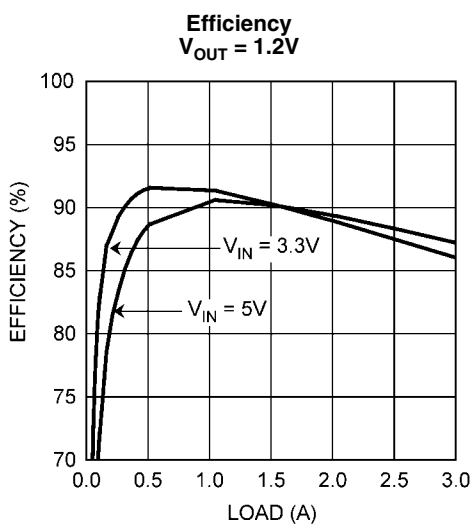

30111868

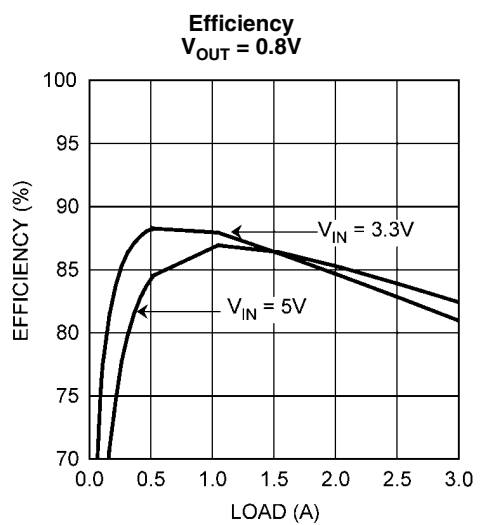

30111867

**Current Derating**  
 $V_{IN} = 5V, \theta_{JA} = 20^{\circ}C / W$

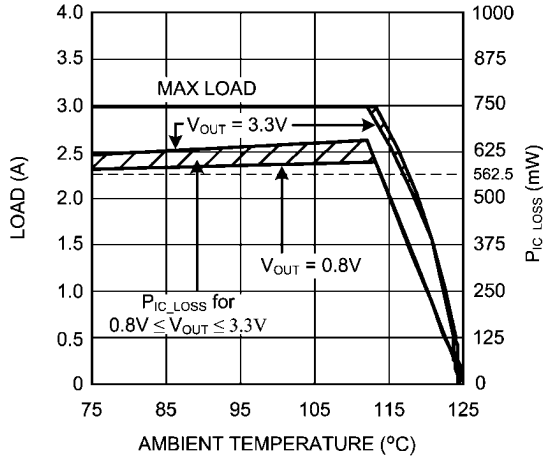

301118b3

**Current Derating**  
 $V_{IN} = 3.3V, \theta_{JA} = 20^{\circ}C / W$

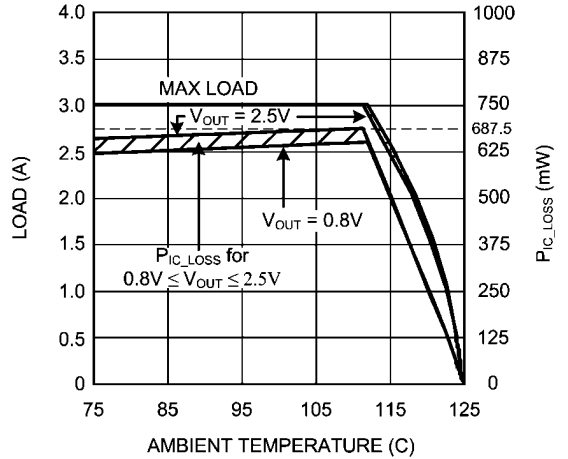

301118b4

**Radiated Emissions (EN55022, Class B)**  
 $V_{IN} = 5V, V_{OUT} = 2.5V, I_{OUT} = 3A$   
 Evaluation board

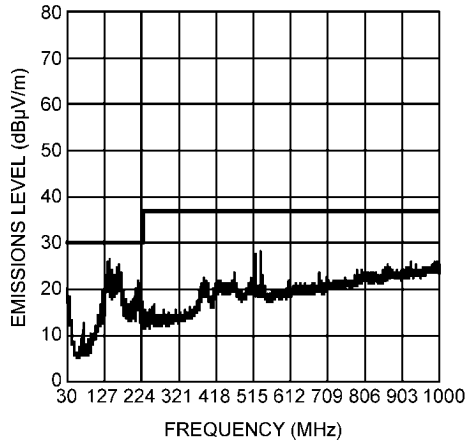

301118a6

**Startup**  
 $V_{OUT} = 2.5V, I_{OUT} = 0A$

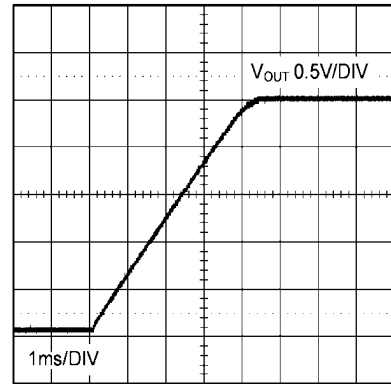

30111856

**Pre-biased Startup**  
 $V_{OUT} = 2.5V, I_{OUT} = 0A$

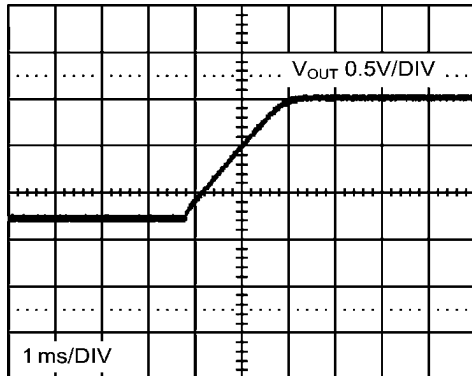

30111855



## Block Diagram

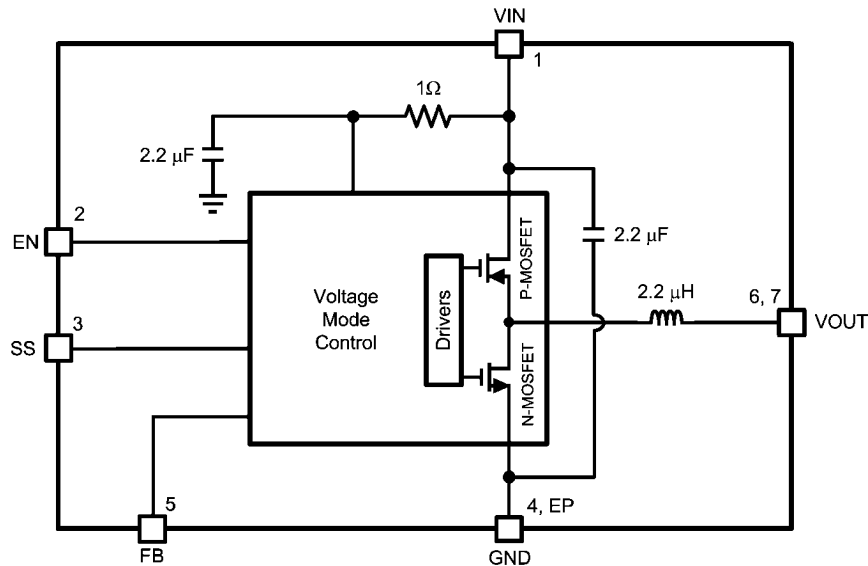

30111836

## General Description

The LMZ10503 SIMPLE SWITCHER® power module is a complete, easy-to-use DC-DC solution capable of driving up to a 3A load with exceptional power conversion efficiency, output voltage accuracy, line and load regulation. The LMZ10503 is available in an innovative package that enhances thermal performance and allows for hand or machine soldering.

The LMZ10503 can accept an input voltage rail between 2.95V and 5.5V and deliver an adjustable and highly accurate output voltage as low as 0.8V. One megahertz fixed frequency PWM switching provides a predictable EMI characteristic. Two external compensation components can be adjusted to set the fastest response time, while allowing the option to use ceramic and/or electrolytic output capacitors. Externally programmable soft-start capacitor facilitates controlled startup. The LMZ10503 is a reliable and robust solution with the following features: lossless cycle-by-cycle peak current limit to protect for over current or short-circuit fault, thermal shutdown, input under-voltage lock-out, and pre-biased startup.

## Design Guideline And Operating Description

### Design Steps

LMZ10503 is fully supported by Webench® and offers the following: component selection, performance, electrical, and thermal simulations as well as the Build-It board, for a reduced design time. On the other hand, all external components can be calculated by following the design procedure below.

1. Determine the input voltage and output voltage. Also, make note of the ripple voltage and voltage transient requirements.
2. Determine the necessary input and output capacitance.
3. Calculate the feedback resistor divider.
4. Select the optimized compensation component values.
5. Estimate the power dissipation and board thermal requirements.

6. Follow the PCB design guideline.

7. Learn about the LMZ10503 features such as enable, input UVLO, soft-start, tracking, pre-biased startup, current limit, and thermal shutdown.

## Design Example

For this example the following application parameters exist.

- $V_{IN} = 5V$
- $V_{OUT} = 2.5V$
- $I_{OUT} = 3A$
- $\Delta V_{OUT} = 20 \text{ mV}_{pk-pk}$
- $\Delta V_{o\_tran} = \pm 20 \text{ mV}_{pk-pk}$

## Input Capacitor Selection

A 22  $\mu F$  or 47  $\mu F$  high quality dielectric (X5R, X7R) ceramic capacitor rated at twice the maximum input voltage is typically sufficient. The input capacitor must be placed as close as possible to the VIN pin and GND exposed pad to substantially eliminate the parasitic effects of any stray inductance or resistance on the PC board and supply lines.

Neglecting capacitor equivalent series resistance (ESR), the resultant input capacitor AC ripple voltage is a triangular waveform. The minimum input capacitance for a given peak-to-peak value ( $\Delta V_{IN}$ ) of  $V_{IN}$  is specified as follows:

$$C_{in} \geq \frac{I_{OUT} \times D \times (1 - D)}{f_{SW} \times \Delta V_{IN}}$$

where the PWM duty cycle, D, is given by:

$$D = \frac{V_{OUT}}{V_{IN}}$$

If  $\Delta V_{IN}$  is 1% of  $V_{IN}$ , this equals to 50 mV and  $f_{SW} = 1 \text{ MHz}$

$$C_{in} \geq \frac{3A \times \left(\frac{2.5V}{5V}\right) \times \left(1 - \frac{2.5V}{5V}\right)}{1 \text{ MHz} \times 50 \text{ mV}} \geq 15 \mu\text{F}$$

A second criteria before finalizing the  $C_{in}$  bypass capacitor is the RMS current capability. The necessary RMS current rating of the input capacitor to a buck regulator can be estimated by

$$I_{Cin(RMS)} = I_{OUT} \times \sqrt{D(1-D)}$$

$$I_{Cin(RMS)} = 3A \times \sqrt{\frac{2.5V}{5V} \left(1 - \frac{2.5V}{5V}\right)} = 1.5A$$

With this high AC current present in the input capacitor, the RMS current rating becomes an important parameter. The maximum input capacitor ripple voltage and RMS current occur at 50% duty cycle. Select an input capacitor rated for at least the maximum calculated  $I_{Cin(RMS)}$ .

Additional bulk capacitance with higher ESR may be required to damp any resonance effects of the input capacitance and parasitic inductance.

## Output Capacitor Selection

In general, 22  $\mu\text{F}$  to 100  $\mu\text{F}$  high quality dielectric (X5R, X7R) ceramic capacitor rated at twice the maximum output voltage is sufficient given the optimal high frequency characteristics and low ESR of ceramic dielectrics. Although, the output capacitor can also be of electrolytic chemistry for increased capacitance density.

Two output capacitance equations are required to determine the minimum output capacitance. One equation determines the output capacitance ( $C_O$ ) based on PWM ripple voltage. The second equation determines  $C_O$  based on the load transient characteristics. Select the largest capacitance value of the two.

The minimum capacitance, given the maximum output voltage ripple ( $\Delta V_{OUT}$ ) requirement, is determined by the following equation:

$$C_O \geq \frac{\Delta i_L}{8 \times f_{SW} \times [\Delta V_{OUT} - (\Delta i_L \times R_{ESR})]}$$

Where the peak to peak inductor current ripple ( $\Delta i_L$ ) is equal to:

$$\Delta i_L = \frac{(V_{IN} - V_{OUT}) \times D}{L \times f_{SW}}$$

$R_{ESR}$  is the total output capacitor ESR, L is the inductance value of the internal power inductor, where  $L = 2.2 \mu\text{H}$ , and  $f_{SW} = 1 \text{ MHz}$ . Therefore, per the design example:

$$\Delta i_L = \frac{(5V - 2.5V) \times \frac{2.5V}{5V}}{2.2 \mu\text{H} \times 1 \text{ MHz}} = 568 \text{ mA}$$

The minimum output capacitance requirement due to the PWM ripple voltage is:

$$C_O \geq \frac{568 \text{ mA}}{8 \times 1 \text{ MHz} \times [20 \text{ mV} - (568 \text{ mA} \times 3 \text{ m}\Omega)]}$$

$$C_O \geq 4 \mu\text{F}$$

Three milliohms is a typical  $R_{ESR}$  value for ceramic capacitors. The following equation provides a good first pass capacitance requirement for a load transient:

$$C_O \geq \frac{I_{step} \times V_{FB} \times L \times V_{IN}}{4 \times V_{OUT} \times (V_{IN} - V_{OUT}) \times \Delta V_{o\_tran}}$$

Where  $I_{step}$  is the peak to peak load step (for this example  $I_{step} = 10\%$  to  $90\%$  of the maximum load),  $V_{FB} = 0.8V$ , and  $\Delta V_{o\_tran}$  is the maximum output voltage deviation, which is  $\pm 20 \text{ mV}$ .

Therefore the capacitance requirement for the given design parameters is:

$$C_O \geq \frac{2.4A \times 0.8V \times 2.2 \mu\text{H} \times 5V}{4 \times 2.5V \times (5V - 2.5V) \times 20 \text{ mV}}$$

$$C_O \geq 42 \mu\text{F}$$

In this particular design the output capacitance is determined by the load transient requirements.

[Table 1](#) lists some examples of commercially available capacitors that can be used with the LMZ10503.

TABLE 1. Recommended Output Filter Capacitors

C <sub>O</sub> (μF)	Voltage (V), R <sub>ESR</sub> (mΩ)	Make	Manufacturer	Part Number	Case Size
22	6.3, < 5	Ceramic, X5R	TDK	C3216X5R0J226M	1206
47	6.3, < 5	Ceramic, X5R	TDK	C3216X5R0J476M	1206
47	6.3, < 5	Ceramic, X5R	TDK	C3225X5R0J476M	1210
47	10.0, < 5	Ceramic, X5R	TDK	C3225X5R1A476M	1210
100	6.3, < 5	Ceramic, X5R	TDK	C3225X5R0J107M	1210
100	6.3, 50	Tantalum	AVX	TPSD157M006#0050	D, 7.5 x 4.3 x 2.9 mm
100	6.3, 25	Organic Polymer	Sanyo	6TPE100MPB2	B2, 3.5 x 2.8 x 1.9 mm
150	6.3, 18	Organic Polymer	Sanyo	6TPE150MIC2	C2, 6.0 x 3.2 x 1.8 mm
330	6.3, 18	Organic Polymer	Sanyo	6TPE330MIL	D3L, 7.3 x 4.3 x 2.8 mm
470	6.3, 23	Niobium Oxide	AVX	NOME37M006#0023	E, 7.3 x 4.3 x 4.1 mm

### Output Voltage Setting

A resistor divider network from V<sub>OUT</sub> to the FB pin determines the desired output voltage as follows:

$$V_{OUT} = 0.8V \times \frac{R_{fbt} + R_{fbb}}{R_{fbb}}$$

R<sub>fbt</sub> is defined based on the voltage loop requirements and R<sub>fbb</sub> is then selected for the desired output voltage. Resistors are normally selected as 0.5% or 1% tolerance. Higher accuracy resistors such as 0.1% are also available.

The feedback voltage (at V<sub>OUT</sub> = 2.5V) is accurate to within -2.5% / +2.5% over temperature and over line and load regulation. Additionally, the LMZ10503 contains error nulling circuitry to substantially eliminate the feedback voltage variation over temperature as well as the long term aging effects of the internal amplifiers. In addition the zero nulling circuit dramatically reduces the 1/f noise of the bandgap amplifier and reference. The manifestation of this circuit action is that the duty cycle will have two slightly different but distinct operating points, each evident every other switching cycle.

### Loop Compensation

The LMZ10503 preserves flexibility by integrating the control components around the internal error amplifier while utilizing three small external compensation components from V<sub>OUT</sub> to FB. An integrated type II (two pole, one zero) voltage-mode compensation network is featured. To ensure stability, an external resistor and small value capacitor can be added across the upper feedback resistor as a pole-zero pair to complete a type III (three pole, two zero) compensation network. The compensation components recommended in [Table 2](#) provide type III compensation at an optimal control loop performance. The typical phase margin is 45° with a bandwidth of 80 kHz. Calculated output capacitance values not listed in [Table 2](#) should be verified before designing into production. A detailed application note is available to provide verification support, AN-2013. In general, calculated output capacitance values below the suggested value will have reduced phase margin and higher control loop bandwidth. Output capacitance values above the suggested values will experience a lower bandwidth and increased phase margin. Higher bandwidth is associated with faster system response to sudden changes such as load transients. Phase margin changes the characteristics of the response. Lower phase margin is associated with underdamped ringing and higher phase margin is associated with overdamped response. Losing all phase margin will cause the system to be unstable; an optimized area of

operation is 30° to 60° of phase margin, with a bandwidth of 100 kHz ±20 kHz.

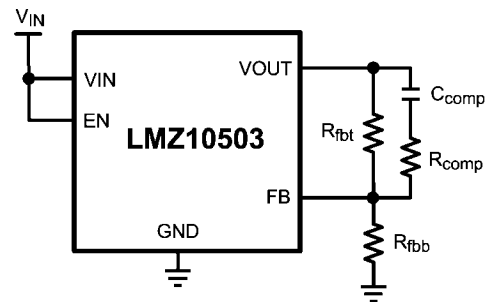

30111848

TABLE 2. LMZ10503 Compensation Component Values

V <sub>IN</sub> (V)	C <sub>O</sub> (μF)	ESR (mΩ)		R <sub>fbt</sub> (kΩ)	C <sub>comp</sub> (pF)	R <sub>comp</sub> (kΩ)
		Min	Max			
5.0	22	2	20	143	39	8.06
	47	2	20	100	100	8.25
	100	1	10	71.5	180	4.32
	150	1	5	56.2	270	2.1
	150	10	25	59	270	10.8
	150	26	50	66.5	270	23.7
	220	15	30	53.6	360	14
	220	31	60	59	360	30.1
3.3	22	2	20	100	56.2	5.62
	47	2	20	66.5	150	5.49
	100	1	10	45.3	270	2.8
	150	1	5	40.2	360	1.5
	150	10	25	40.2	360	7.32
	150	26	50	43.2	360	15.4
	220	15	30	40.2	470	10.5
	220	31	60	40.2	470	20.5

Note: In the special case where the output voltage is 0.8V, it is recommended to remove R<sub>fbb</sub> and keep R<sub>fbt</sub>, R<sub>comp</sub>, and C<sub>comp</sub> for a type III compensation.

## Estimate Power Dissipation And Board Thermal Requirements

Use the current derating curves in the typical performance characteristics section to obtain an estimate of power loss ( $P_{IC\_LOSS}$ ). For the design case of  $V_{IN} = 5V$ ,  $V_{OUT} = 2.5V$ ,  $I_{OUT} = 3A$ ,  $T_{A(MAX)} = 85^{\circ}C$ , and  $T_{J(MAX)} = 125^{\circ}C$ , the device must see a thermal resistance from case to ambient ( $\theta_{CA}$ ) of less than:

$$\theta_{CA} < \frac{T_{J(MAX)} - T_{A(MAX)}}{P_{IC\_LOSS}} - \theta_{JC}$$

$$\theta_{CA} < \frac{125^{\circ}C - 85^{\circ}C}{0.56 W} - 1.9 \frac{^{\circ}C}{W} < 69.5 \frac{^{\circ}C}{W}$$

Given the typical thermal resistance from junction to case ( $\theta_{JC}$ ) to be  $1.9^{\circ}C/W$  (typ.). Continuously operating at a  $T_J$  greater than  $125^{\circ}C$  will have a shorten life span.

To reach  $\theta_{CA} = 69.5^{\circ}C/W$ , the PCB is required to dissipate heat effectively. With no airflow and no external heat, a good estimate of the required board area covered by 1oz. copper on both the top and bottom metal layers is:

$$\text{Board Area}_{cm^2} \geq \frac{500}{\theta_{CA}} \cdot \frac{^{\circ}C \times cm^2}{W}$$

$$\text{Board Area}_{cm^2} \geq \frac{500}{69.5 \frac{^{\circ}C}{W}} \cdot \frac{^{\circ}C \times cm^2}{W}$$

As a result, approximately 7.2 square cm of 1oz. copper on top and bottom layers is required for the PCB design.

The PCB copper heat sink must be connected to the exposed pad (EP). Approximately thirty six, 10mils (254  $\mu m$ ) thermal vias spaced 59mils (1.5 mm) apart must connect the top copper to the bottom copper. For an extended discussion and formulations of thermal rules of thumb, refer to AN-2020. For an example of a high thermal performance PCB layout with  $\theta_{JA}$  of  $20^{\circ}C/W$ , refer to the evaluation board application note AN-2022 and for results of a study of the effects of the PCB designs, refer to AN-2026.

## PC Board Layout Guidelines

PC board layout is an important part of DC-DC converter design. Poor board layout can disrupt the performance of a DC-DC converter and surrounding circuitry by contributing to EMI, ground bounce and resistive voltage drop in the traces. These can send erroneous signals to the DC-DC converter resulting in poor regulation or instability. Good layout can be implemented by following a few simple design rules.

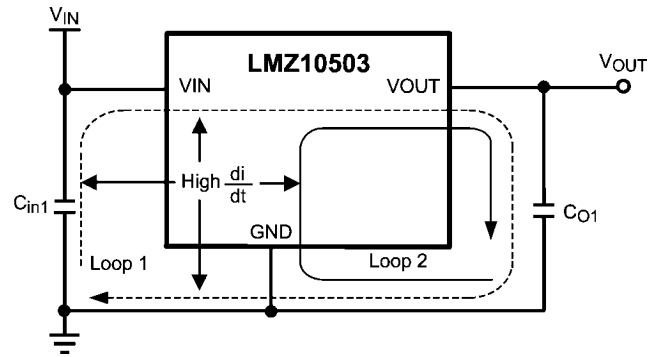

301118b5

FIGURE 1. High Current Loops

### 1. Minimize area of switched current loops.

From an EMI reduction standpoint, it is imperative to minimize the high di/dt current paths. The high current that does not overlap contains high di/dt, see [Figure 1](#). Therefore physically place input capacitor ( $C_{in1}$ ) as close as possible to the LMZ10503 VIN pin and GND exposed pad to avoid observable high frequency noise on the output pin. This will minimize the high di/dt area and reduce radiated EMI. Additionally, grounding for both the input and output capacitor should consist of a localized top side plane that connects to the GND exposed pad (EP).

### 2. Have a single point ground.

The ground connections for the feedback, soft-start, and enable components should be routed only to the GND pin of the device. This prevents any switched or load currents from flowing in the analog ground traces. If not properly placed, poor grounding can result in degraded load regulation or erratic output voltage ripple behavior. Provide the single point ground connection from pin 4 to EP.

### 3. Minimize trace length to the FB pin.

Both feedback resistors,  $R_{fbt}$  and  $R_{fbb}$ , and the compensation components,  $R_{comp}$  and  $C_{comp}$ , should be located close to the FB pin. Since the FB node is high impedance, keep the copper area as small as possible. This is most important as relatively high value resistors are used to set the output voltage.

### 4. Make input and output bus connections as wide as possible.

This reduces any voltage drops on the input or output of the converter and maximizes efficiency. To optimize voltage accuracy at the load, ensure that a separate feedback voltage sense trace is made at the load. Doing so will correct for voltage drops and provide optimum output accuracy.

### 5. Provide adequate device heat-sinking.

Use an array of heat-sinking vias to connect the exposed pad to the ground plane on the bottom PCB layer. If the PCB has multiple copper layers, thermal vias can also be employed to make connection to inner layer heat-spreading ground planes. For best results use a  $6 \times 6$  via array with minimum via diameter of 10mils (254  $\mu m$ ) thermal vias spaced 59mils (1.5 mm). Ensure enough copper area is used for heat-sinking to keep the junction temperature below  $125^{\circ}C$ .

## Additional Features

### Enable

The LMZ10503 features an enable (EN) pin and associated comparator to allow the user to easily sequence the LMZ10503 from an external voltage rail, or to manually set the input UVLO threshold. The turn-on or rising threshold and hysteresis for this comparator are typically 1.23V and 0.15V respectively. The precise reference for the enable comparator allows the user to guarantee that the LMZ10503 will be disabled when the system demands it to be.

### Enable AND UVLO

Using a resistor divider from VIN to EN as shown in the schematic diagram below, the input voltage at which the part begins switching can be increased above the normal input UVLO level according to

$$V_{IN(UVLO)} = 1.23V \times \frac{R_{ent} + R_{enb}}{R_{enb}}$$

For example, suppose that the required input UVLO level is 3.69V. Choosing  $R_{enb} = 10 \text{ k}\Omega$ , then we calculate  $R_{ent} = 20 \text{ k}\Omega$ .

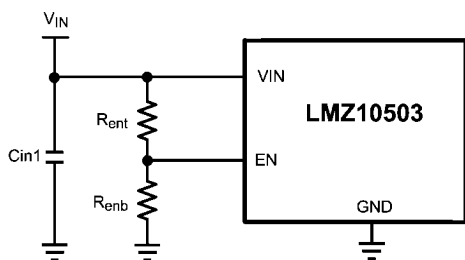

30111844

Alternatively, the EN pin can be driven from another voltage source to cater to system sequencing requirements commonly found in FPGA and other multi-rail applications. The following schematic shows an LMZ10503 that is sequenced to start based on the voltage level of a master system rail ( $V_{OUT1}$ ).

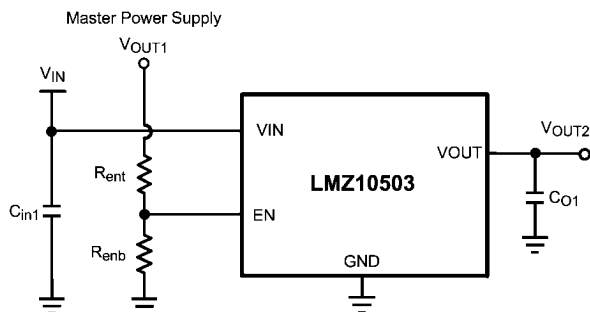

30111845

### Soft-Start

The LMZ10503 begins to operate when both the VIN and EN, voltages exceed the rising UVLO and enable thresholds, respectively. A controlled soft-start eliminates inrush currents during startup and allows the user more control and flexibility when sequencing the LMZ10503 with other power supplies.

In the event of either VIN or EN decreasing below the falling UVLO or enable threshold respectively, the voltage on the soft-start pin is collapsed by discharging the soft-start capacitor by a 14  $\mu\text{A}$  (typ.) current sink to ground.

### Soft-Start Capacitor

Determine the soft-start capacitance with the following relationship

$$C_{SS} = \frac{t_{SS} \times I_{SS}}{V_{FB}}$$

where  $V_{FB}$  is the internal reference voltage (nominally 0.8V),  $I_{SS}$  is the soft-start charging current (nominally 2  $\mu\text{A}$ ) and  $C_{SS}$  is the external soft-start capacitance.

Thus, the required soft-start capacitor per unit output voltage startup time is given by

$$C_{SS} = 2.5 \text{ nF} / \text{ms}$$

For example, a 4 ms soft-start time will yield a 10 nF capacitance. The minimum soft-start capacitance is 680 pF.

### Tracking

The LMZ10503 can track the output of a master power supply during soft-start by connecting a resistor divider to the SS pin. In this way, the output voltage slew rate of the LMZ10503 will be controlled by a master supply for loads that require precise sequencing. When the tracking function is used, a small value soft-start capacitor should be connected to the SS pin to alleviate output voltage overshoot when recovering from a current limit fault.

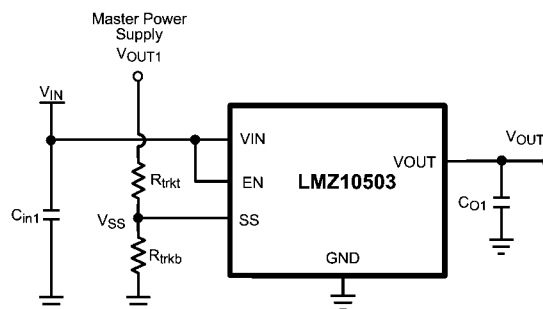

30111857

### Tracking - Equal Soft-Start Time

One way to use the tracking feature is to design the tracking resistor divider so that the master supply output voltage,  $V_{OUT1}$ , and the LMZ10503 output voltage,  $V_{OUT2}$ , both rise together and reach their target values at the same time. This is termed ratiometric startup. For this case, the equation governing the values of tracking divider resistors  $R_{trkb}$  and  $R_{trkt}$  is given by

$$R_{trkb} = \frac{R_{trkt}}{V_{OUT1} - 1.0V}$$

The above equation includes an offset voltage, of 200 mV, to ensure that the final value of the SS pin voltage exceeds the reference voltage of the LMZ10503. This offset will cause the LMZ10503 output voltage to reach regulation slightly before the master supply. A value of 33  $\text{k}\Omega$  1% is recommended for  $R_{trkt}$  as a compromise between high precision and low quies-

cent current through the divider while minimizing the effect of the 2  $\mu\text{A}$  soft-start current source.

For example, if the master supply voltage  $V_{\text{OUT1}}$  is 3.3V and the LMZ10503 output voltage was 1.8V, then the value of  $R_{\text{trkb}}$  needed to give the two supplies identical soft-start times would be 14.3 k $\Omega$ . A timing diagram for this example, the equal soft-start time case, is shown below.

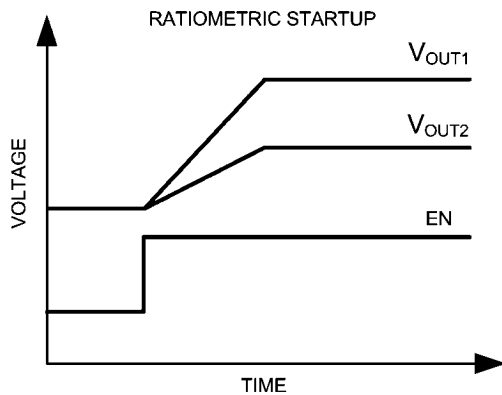

30111859

## Tracking - Equal Slew Rates

Alternatively, the tracking feature can be used to have similar output voltage ramp rates. This is referred to as simultaneous startup. In this case, the tracking resistors can be determined based on the following equation

$$R_{\text{trkb}} = \frac{0.8V}{V_{\text{OUT2}} - 0.8V} \times R_{\text{trkt}}$$

and to ensure proper overdrive of the SS pin

$$V_{\text{OUT2}} < 0.8 \times V_{\text{OUT1}}$$

For the example case of  $V_{\text{OUT1}} = 5\text{V}$  and  $V_{\text{OUT2}} = 2.5\text{V}$ , with  $R_{\text{trkt}}$  set to 33 k $\Omega$  as before,  $R_{\text{trkb}}$  is calculated from the above equation to be 15.5 k $\Omega$ . A timing diagram for the case of equal slew rates is shown below.

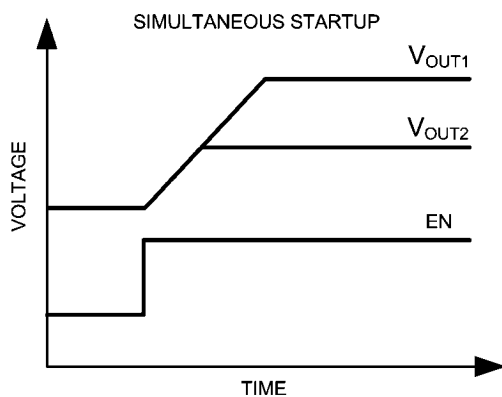

30111861

## Pre-Bias Startup Capability

At startup, the LMZ10503 is in a pre-biased state when the output voltage is greater than zero. This often occurs in many multi-rail applications such as when powering an ASIC, FPGA, or DSP. The output can be pre-biased in these applications through parasitic conduction paths from one supply rail to another. Even though the LMZ10503 is a synchronous converter, it will not pull the output low when a pre-bias condition exists. The LMZ10503 will not sink current during startup until the soft-start voltage exceeds the voltage on the FB pin. Since the device does not sink current it protects the load from damage that might otherwise occur if current is conducted through the parasitic paths of the load.

## Current Limit

When a current greater than the output current limit ( $I_{\text{OCL}}$ ) is sensed, the on-time is immediately terminated and the low side MOSFET is activated. The low side MOSFET stays on for the entire next four switching cycles. During these skipped pulses, the voltage on the soft-start pin is reduced by discharging the soft-start capacitor by a current sink on the soft-start pin of nominally 14  $\mu\text{A}$ . Subsequent over-current events will drain more and more charge from the soft-start capacitor, effectively decreasing the reference voltage as the output droops due to the pulse skipping. Reactivation of the soft-start circuitry ensures that when the over-current situation is removed, the part will resume normal operation smoothly.

## Over-Temperature Protection

When the LMZ10503 senses a junction temperature greater than 145 $^{\circ}\text{C}$  (typ.), both switching MOSFETs are turned off and the part enters a standby state. Upon sensing a junction temperature below 135 $^{\circ}\text{C}$  (typ.), the part will re-initiate the soft-start sequence and begin switching once again.

## LMZ10503 Application Circuit Schematic and BOMs

This section provides several application solutions with an associated bill of materials. The compensation for each solution was optimized to work over the full input range. Many

applications have a fixed input voltage rail. It is possible to modify the compensation to obtain a faster transient response for a given input voltage operating point.

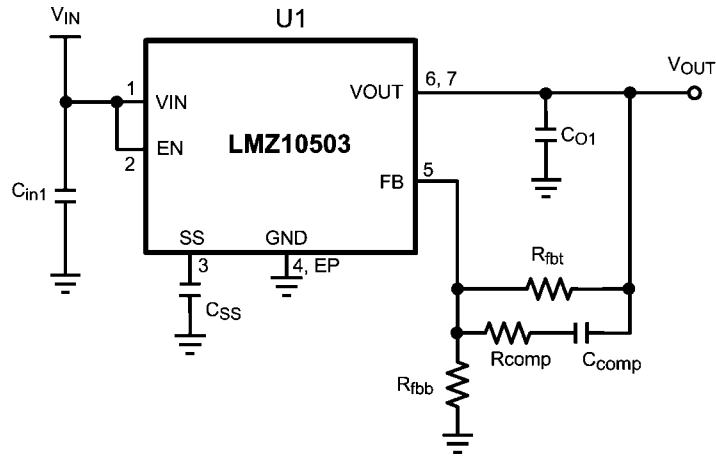

30111854

FIGURE 2.

TABLE 3. Bill of Materials,  $V_{IN} = 3.3V$  to  $5V$ ,  $V_{OUT} = 2.5V$ ,  $I_{OUT(MAX)} = 3A$ , Optimized for Electrolytic Input and Output Capacitance

Designator	Description	Case Size	Manufacturer	Manufacturer P/N	Quantity
U1	SIMPLE SWITCHER ®	TO-PMOD-7	National Semiconductor	LMZ10503TZ-ADJ	1
$C_{in1}$	150 $\mu F$ , 6.3V, 18 m $\Omega$	C2, 6.0 x 3.2 x 1.8 mm	Sanyo	6TPE150MIC2	1
$C_{O1}$	330 $\mu F$ , 6.3V, 18 m $\Omega$	D3L, 7.3 x 4.3 x 2.8 mm	Sanyo	6TPE330MIL	1
$R_{fbt}$	100 k $\Omega$	0603	Vishay Dale	CRCW0603100KFKEA	1
$R_{fbb}$	47.5 k $\Omega$	0603	Vishay Dale	CRCW060347K5FKEA	1
$R_{comp}$	15 k $\Omega$	0603	Vishay Dale	CRCW060315K0FKEA	1
$C_{comp}$	330 pF, $\pm 5\%$ , C0G, 50V	0603	TDK	C1608C0G1H331J	1
$C_{SS}$	10 nF, $\pm 10\%$ , X7R, 16V	0603	Murata	GRM188R71C103KA01	1

TABLE 4. Bill of Materials,  $V_{IN} = 3.3V$ ,  $V_{OUT} = 0.8V$ ,  $I_{OUT(MAX)} = 3A$ , Optimized for Solution Size and Transient Response

Designator	Description	Case Size	Manufacturer	Manufacturer P/N	Quantity
U1	SIMPLE SWITCHER ®	TO-PMOD-7	National Semiconductor	LMZ10503TZ-ADJ	1
$C_{in1}, C_{O1}$	47 $\mu F$ , X5R, 6.3V	1206	TDK	C3216X5R0J476M	2
$R_{fbt}$	110 k $\Omega$	0402	Vishay Dale	CRCW0402100KFKEA	1
$R_{comp}$	1.0 k $\Omega$	0402	Vishay Dale	CRCW04021K00FKED	1
$C_{comp}$	27 pF, $\pm 5\%$ , C0G, 50V	0402	Murata	GRM1555C1H270JZ01	1
$C_{SS}$	10 nF, $\pm 10\%$ , X7R, 16V	0402	Murata	GRM155R71C103KA01	1

In the case where the output voltage is 0.8V, it is recommended to remove  $R_{fbb}$  and keep  $R_{fbt}$ ,  $R_{comp}$ , and  $C_{comp}$  for a type III compensation.

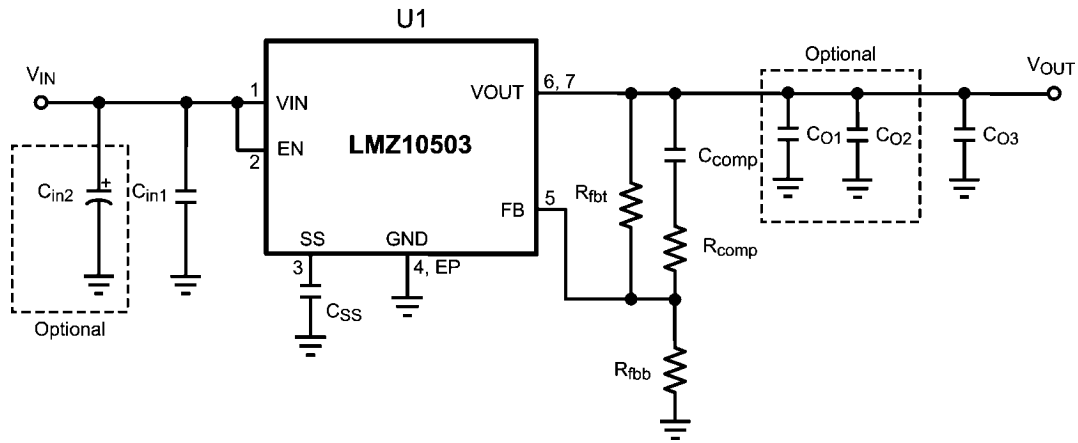

30111881

FIGURE 3.

**TABLE 5. Bill of Materials,  $V_{IN} = 3.3V$  to  $5V$ ,  $V_{OUT} = 2.5V$ ,  $I_{OUT(MAX)} = 3A$ , Optimized for Low Input and Output Ripple Voltage and Fast Transient Response**

Designator	Description	Case Size	Manufacturer	Manufacturer P/N	Quantity
U1	SIMPLE SWITCHER®	TO-PMOD-7	National Semiconductor	LMZ10503TZ-ADJ	1
$C_{in1}$	22 $\mu F$ , X5R, 10V	1210	AVX	1210ZD226MAT	2
$C_{in2}$	220 $\mu F$ , 10V, AL-Elec	E	Panasonic	EEE1AA221AP	1*
$C_{O1}$	4.7 $\mu F$ , X5R, 10V	0805	AVX	0805ZD475MAT	1*
$C_{O2}$	22 $\mu F$ , X5R, 6.3V	1206	AVX	12066D226MAT	1*
$C_{O3}$	100 $\mu F$ , X5R, 6.3V	1812	AVX	18126D107MAT	1
$R_{fbt}$	75 $k\Omega$	0402	Vishay Dale	CRCW040275K0FKED	1
$R_{fbb}$	34.8 $k\Omega$	0402	Vishay Dale	CRCW040234K8FKED	1
$R_{comp}$	1.0 $k\Omega$	0402	Vishay Dale	CRCW04021K00FKED	1
$C_{comp}$	220 pF, $\pm 5\%$ , C0G, 50V	0402	Murata	GRM1555C1H221JA01D	1
$C_{SS}$	10 nF, $\pm 10\%$ , X7R, 16V	0402	Murata	GRM155R71C103KA01	1

\* Optional components, include for low input and output voltage ripple.

**TABLE 6. Output Voltage Setting ( $R_{fbt} = 75 k\Omega$ )**

$V_{OUT}$	$R_{fbb}$
3.3V	23.7 $k\Omega$
2.5 V	34.8 $k\Omega$
1.8 V	59 $k\Omega$
1.5 V	84.5 $k\Omega$
1.2 V	150 $k\Omega$
0.9 V	590 $k\Omega$



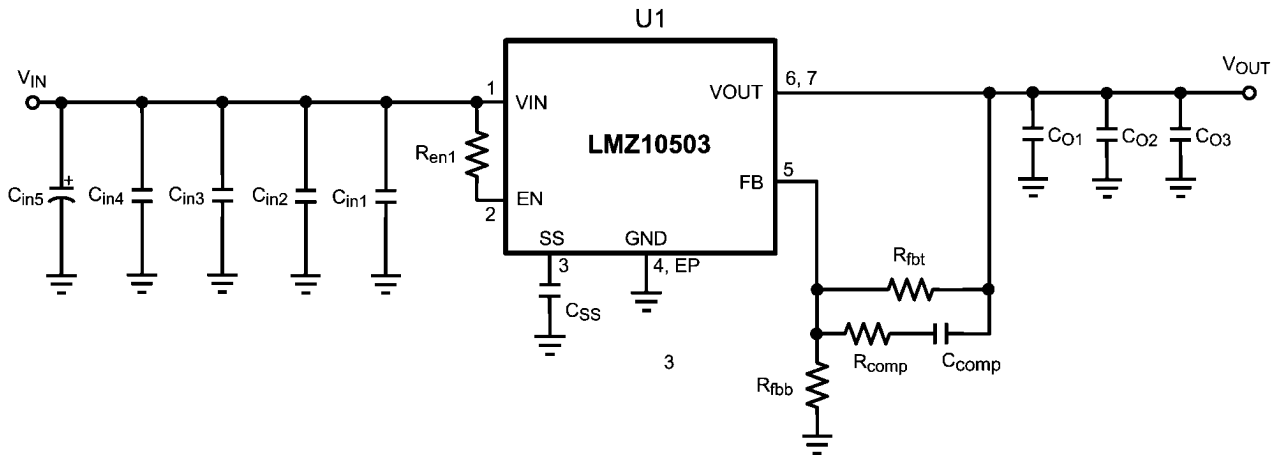

30111880

FIGURE 4.

TABLE 7. Bill of Materials for Evaluation Board,  $V_{IN} = 3.3V$  to  $5V$ ,  $V_{OUT} = 2.5V$ ,  $I_{OUT(MAX)} = 3A$ 

Designator	Description	Case Size	Manufacturer	Manufacturer P/N	Quantity
U1	SIMPLE SWITCHER®	TO-PMOD-7	National Semiconductor	LMZ10503TZ-ADJ	1
$C_{in1}$	1 $\mu F$ , X7R, 16V	0805	TDK	C2012X7R1C105K	1
$C_{in2}$ , $C_{O1}$	4.7 $\mu F$ , X5R, 6.3V	0805	TDK	C2012X5R0J475K	2
$C_{in3}$ , $C_{O2}$	22 $\mu F$ , X5R, 16V	1210	TDK	C3225X5R1C226M	2
$C_{in4}$	47 $\mu F$ , X5R, 6.3V	1210	TDK	C3225X5R0J476M	1
$C_{in5}$	220 $\mu F$ , 10V, AL-Elec	E	Panasonic	EEE1AA221AP	1
$C_{O3}$	100 $\mu F$ , X5R, 6.3V	1812	TDK	C4532X5R0J107M	1
$R_{fbt}$	75 $k\Omega$	0805	Vishay Dale	CRCW080575K0FKEA	1
$R_{fbb}$	34.8 $k\Omega$	0805	Vishay Dale	CRCW080534K8FKEA	1
$R_{comp}$	1.1 $k\Omega$	0805	Vishay Dale	CRCW08051K10FKEA	1
$C_{comp}$	180 pF, $\pm 5\%$ , C0G, 50V	0603	TDK	C1608C0G1H181J	1
$R_{en1}$	100 $k\Omega$	0805	Vishay Dale	CRCW0805100KFKEA	1
$C_{SS}$	10 nF, $\pm 5\%$ , C0G, 50V	0805	TDK	C2012C0G1H103J	1

TABLE 8. Output Voltage Setting ( $R_{fbt} = 75 k\Omega$ )

$V_{OUT}$	$R_{fbb}$
3.3V	23.7 $k\Omega$
2.5 V	34.8 $k\Omega$
1.8 V	59 $k\Omega$
1.5 V	84.5 $k\Omega$
1.2 V	150 $k\Omega$
0.9 V	590 $k\Omega$

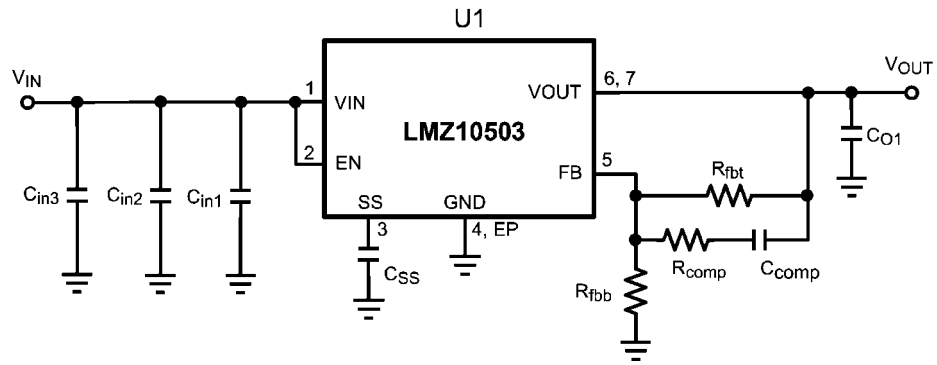

301118b1

FIGURE 5.

TABLE 9. Bill of Materials,  $V_{IN} = 5V$ ,  $V_{OUT} = 2.5V$ ,  $I_{OUT(MAX)} = 3A$ , Complies with EN55022 Class B Radiated Emissions

Designator	Description	Case Size	Manufacturer	Manufacturer P/N	Quantity
U1	SIMPLE SWITCHER®	TO-PMOD-7	National Semiconductor	LMZ10503TZ-ADJ	1
$C_{in1}$	1 $\mu F$ , X7R, 16V	0805	TDK	C2012X7R1C105K	1
$C_{in2}$	4.7 $\mu F$ , X5R, 6.3V	0805	TDK	C2012X5R0J475K	1
$C_{in3}$	47 $\mu F$ , X5R, 6.3V	1210	TDK	C3225X5R0J476M	1
$C_{O1}$	100 $\mu F$ , X5R, 6.3V	1812	TDK	C4532X5R0J107M	1
$R_{fbt}$	75 k $\Omega$	0805	Vishay Dale	CRCW080575K0FKEA	1
$R_{fbb}$	34.8 k $\Omega$	0805	Vishay Dale	CRCW080534K8FKEA	1
$R_{comp}$	1.1 k $\Omega$	0805	Vishay Dale	CRCW08051K10FKEA	1
$C_{comp}$	180 pF, $\pm 5\%$ , C0G, 50V	0603	TDK	C1608C0G1H181J	1
$C_{SS}$	10 nF, $\pm 5\%$ , C0G, 50V	0805	TDK	C2012C0G1H103J	1

TABLE 10. Output Voltage Setting ( $R_{fbt} = 75\text{ k}\Omega$ )

$V_{OUT}$	$R_{fbb}$
3.3 V	23.7 k $\Omega$
2.5 V	34.8 k $\Omega$
1.8 V	59 k $\Omega$
1.5 V	84.5 k $\Omega$
1.2 V	150 k $\Omega$
0.9 V	590 k $\Omega$

## PCB Layout Diagrams

The PCB design is available in the LMZ10503 product folder at [www.national.com](http://www.national.com).

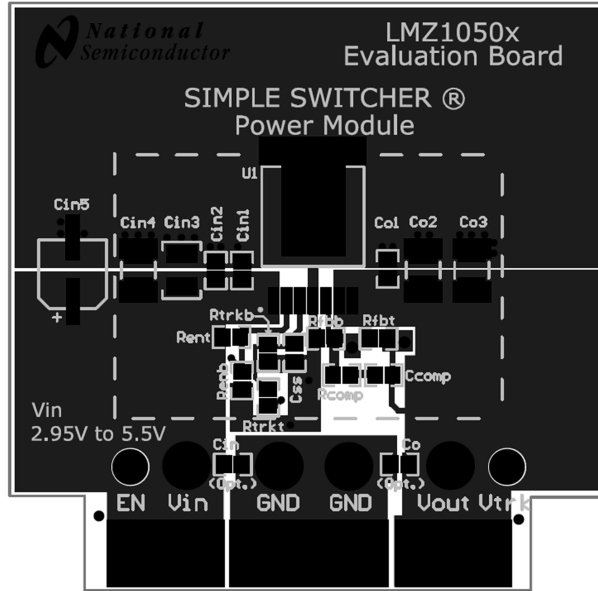

30111876

FIGURE 6. Top Copper

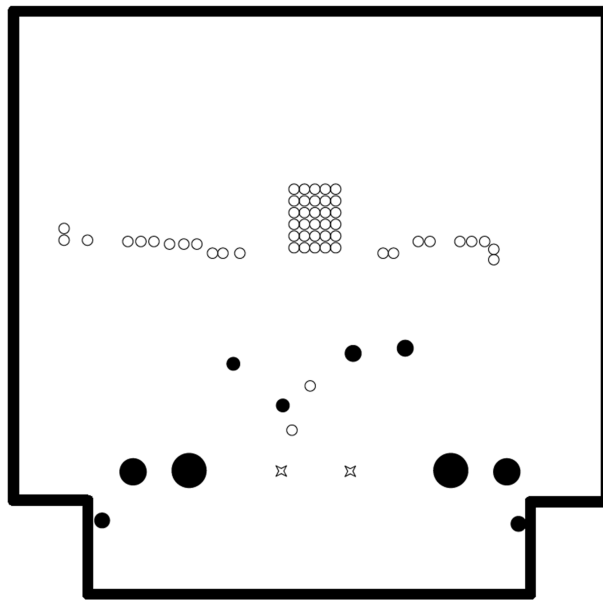

30111877

FIGURE 7. Internal Layer 1 (Ground)

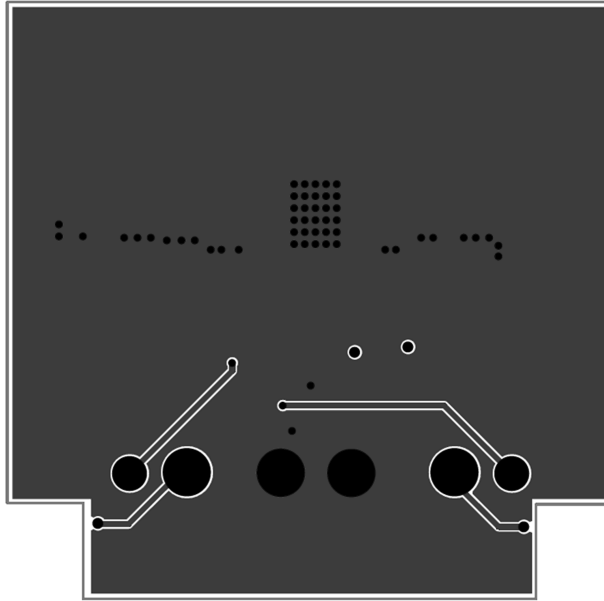

30111878

FIGURE 8. Internal Layer 2 (Ground and Signal Traces)

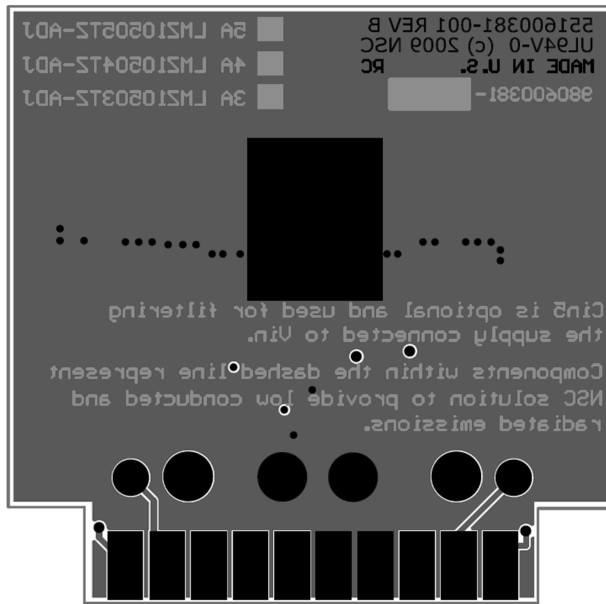

30111879

FIGURE 9. Bottom Copper

**Physical Dimensions** inches (millimeters) unless otherwise noted

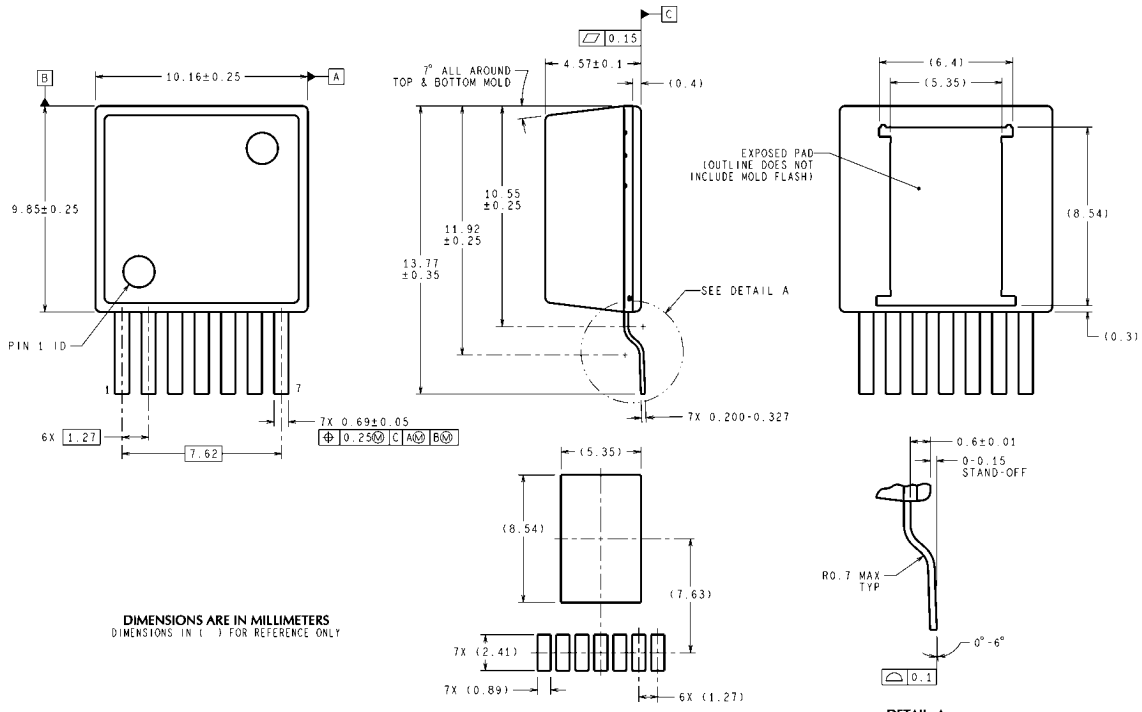

DIMENSIONS ARE IN MILLIMETERS  
DIMENSIONS IN ( ) FOR REFERENCE ONLY

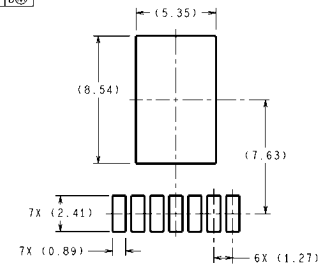

RECOMMENDED LAND PATTERN  
**TO-PMOD-7 Pin Package**  
**NS Package Number TZA07A**

TZA07A (Rev C)

For more National Semiconductor product information and proven design tools, visit the following Web sites at:  
[www.national.com](http://www.national.com)

Products		Design Support	
Amplifiers	<a href="http://www.national.com/amplifiers">www.national.com/amplifiers</a>	WEBENCH® Tools	<a href="http://www.national.com/webench">www.national.com/webench</a>
Audio	<a href="http://www.national.com/audio">www.national.com/audio</a>	App Notes	<a href="http://www.national.com/appnotes">www.national.com/appnotes</a>
Clock and Timing	<a href="http://www.national.com/timing">www.national.com/timing</a>	Reference Designs	<a href="http://www.national.com/refdesigns">www.national.com/refdesigns</a>
Data Converters	<a href="http://www.national.com/adc">www.national.com/adc</a>	Samples	<a href="http://www.national.com/samples">www.national.com/samples</a>
Interface	<a href="http://www.national.com/interface">www.national.com/interface</a>	Eval Boards	<a href="http://www.national.com/evalboards">www.national.com/evalboards</a>
LVDS	<a href="http://www.national.com/lvds">www.national.com/lvds</a>	Packaging	<a href="http://www.national.com/packaging">www.national.com/packaging</a>
Power Management	<a href="http://www.national.com/power">www.national.com/power</a>	Green Compliance	<a href="http://www.national.com/quality/green">www.national.com/quality/green</a>
Switching Regulators	<a href="http://www.national.com/switchers">www.national.com/switchers</a>	Distributors	<a href="http://www.national.com/contacts">www.national.com/contacts</a>
LDOs	<a href="http://www.national.com/ldo">www.national.com/ldo</a>	Quality and Reliability	<a href="http://www.national.com/quality">www.national.com/quality</a>
LED Lighting	<a href="http://www.national.com/led">www.national.com/led</a>	Feedback/Support	<a href="http://www.national.com/feedback">www.national.com/feedback</a>
Voltage References	<a href="http://www.national.com/vref">www.national.com/vref</a>	Design Made Easy	<a href="http://www.national.com/easy">www.national.com/easy</a>
PowerWise® Solutions	<a href="http://www.national.com/powerwise">www.national.com/powerwise</a>	Applications & Markets	<a href="http://www.national.com/solutions">www.national.com/solutions</a>
Serial Digital Interface (SDI)	<a href="http://www.national.com/sdi">www.national.com/sdi</a>	Mil/Aero	<a href="http://www.national.com/milaero">www.national.com/milaero</a>
Temperature Sensors	<a href="http://www.national.com/tempensors">www.national.com/tempensors</a>	SolarMagic™	<a href="http://www.national.com/solarmagic">www.national.com/solarmagic</a>
PLL/VCO	<a href="http://www.national.com/wireless">www.national.com/wireless</a>	PowerWise® Design University	<a href="http://www.national.com/training">www.national.com/training</a>

THE CONTENTS OF THIS DOCUMENT ARE PROVIDED IN CONNECTION WITH NATIONAL SEMICONDUCTOR CORPORATION ("NATIONAL") PRODUCTS. NATIONAL MAKES NO REPRESENTATIONS OR WARRANTIES WITH RESPECT TO THE ACCURACY OR COMPLETENESS OF THE CONTENTS OF THIS PUBLICATION AND RESERVES THE RIGHT TO MAKE CHANGES TO SPECIFICATIONS AND PRODUCT DESCRIPTIONS AT ANY TIME WITHOUT NOTICE. NO LICENSE, WHETHER EXPRESS, IMPLIED, ARISING BY ESTOPPEL OR OTHERWISE, TO ANY INTELLECTUAL PROPERTY RIGHTS IS GRANTED BY THIS DOCUMENT.

TESTING AND OTHER QUALITY CONTROLS ARE USED TO THE EXTENT NATIONAL DEEMS NECESSARY TO SUPPORT NATIONAL'S PRODUCT WARRANTY. EXCEPT WHERE MANDATED BY GOVERNMENT REQUIREMENTS, TESTING OF ALL PARAMETERS OF EACH PRODUCT IS NOT NECESSARILY PERFORMED. NATIONAL ASSUMES NO LIABILITY FOR APPLICATIONS ASSISTANCE OR BUYER PRODUCT DESIGN. BUYERS ARE RESPONSIBLE FOR THEIR PRODUCTS AND APPLICATIONS USING NATIONAL COMPONENTS. PRIOR TO USING OR DISTRIBUTING ANY PRODUCTS THAT INCLUDE NATIONAL COMPONENTS, BUYERS SHOULD PROVIDE ADEQUATE DESIGN, TESTING AND OPERATING SAFEGUARDS.

EXCEPT AS PROVIDED IN NATIONAL'S TERMS AND CONDITIONS OF SALE FOR SUCH PRODUCTS, NATIONAL ASSUMES NO LIABILITY WHATSOEVER, AND NATIONAL DISCLAIMS ANY EXPRESS OR IMPLIED WARRANTY RELATING TO THE SALE AND/OR USE OF NATIONAL PRODUCTS INCLUDING LIABILITY OR WARRANTIES RELATING TO FITNESS FOR A PARTICULAR PURPOSE, MERCHANTABILITY, OR INFRINGEMENT OF ANY PATENT, COPYRIGHT OR OTHER INTELLECTUAL PROPERTY RIGHT.

#### LIFE SUPPORT POLICY

**NATIONAL'S PRODUCTS ARE NOT AUTHORIZED FOR USE AS CRITICAL COMPONENTS IN LIFE SUPPORT DEVICES OR SYSTEMS WITHOUT THE EXPRESS PRIOR WRITTEN APPROVAL OF THE CHIEF EXECUTIVE OFFICER AND GENERAL COUNSEL OF NATIONAL SEMICONDUCTOR CORPORATION.** As used herein:

Life support devices or systems are devices which (a) are intended for surgical implant into the body, or (b) support or sustain life and whose failure to perform when properly used in accordance with instructions for use provided in the labeling can be reasonably expected to result in a significant injury to the user. A critical component is any component in a life support device or system whose failure to perform can be reasonably expected to cause the failure of the life support device or system or to affect its safety or effectiveness.

National Semiconductor and the National Semiconductor logo are registered trademarks of National Semiconductor Corporation. All other brand or product names may be trademarks or registered trademarks of their respective holders.

Copyright© 2010 National Semiconductor Corporation

For the most current product information visit us at [www.national.com](http://www.national.com)



**National Semiconductor  
Americas Technical  
Support Center**  
Email: [support@nsc.com](mailto:support@nsc.com)  
Tel: 1-800-272-9959

**National Semiconductor Europe  
Technical Support Center**  
Email: [europe.support@nsc.com](mailto:europe.support@nsc.com)

**National Semiconductor Asia  
Pacific Technical Support Center**  
Email: [ap.support@nsc.com](mailto:ap.support@nsc.com)

**National Semiconductor Japan  
Technical Support Center**  
Email: [jpn.feedback@nsc.com](mailto:jpn.feedback@nsc.com)