

LMH6609

900MHz Voltage Feedback Op Amp

General Description

The LMH6609 is an ultra wideband, unity gain stable, low power, voltage feedback op amp that offers 900MHz bandwidth at a gain of 1, 1400V/ μ s slew rate and 90mA of linear output current.

The LMH6609 is designed with voltage feedback architecture for maximum flexibility especially for active filters and integrators. The LMH6609 has balanced, symmetrical inputs with well-matched bias currents and minimal offset voltage.

With Differential Gain of .01 and Differential Phase of .026 the LMH6609 is suited for video applications. The 90mA of linear output current makes the LMH6609 suitable for multiple video loads and cable driving applications as well.

The recommended supply voltage range of 6V to 12V and is specified at 6.6 and 10V. A low supply current of 7mA (at 10V supply) makes the LMH6609 useful in a wide variety of platforms, including portable or remote equipment that must run from battery power.

The LMH6609 is available in the industry standard 8-pin SOIC package and in the space-saving 5-pin SOT package. The LMH6609 is specified for operation over the -40°C to +85°C temperature range. The LMH6609 is manufactured in National Semiconductor's state-of-the-art VIP10™ technology for high performance.

Features

- 900MHz -3dB bandwidth ($A_V = 1$)
- Large signal bandwidth and slew rate 100% tested
- 280MHz -3dB bandwidth ($A_V = +2, V_{OUT} = 2V_{PP}$)
- 90mA linear output current
- 1400V/ μ s slew rate
- Unity gain stable
- <1mV input Offset voltage
- 7mA Supply current (no load)
- 6V to 12V supply voltage range
- .01/ .026 differential gain/phase PAL
- 3.1nV/ $\sqrt{\text{Hz}}$ voltage noise
- Improved replacement for CLC440, 420, 426

Applications

- Test equipment
- IF/RF amplifier
- A/D Input driver
- Active filter
- Integrator
- DAC output buffer
- Transimpedance amplifier

Typical Application

$$K = 1 + \frac{R_F}{R_G} \quad Q = \frac{m}{1+m^2} \quad \omega_o = \frac{1}{mRC}$$

Q, K ARE UNITLESS
 ω_o IS IN UNITS OF RADIANS/SEC.
 DIVIDE ω_o BY 2π TO GET IT IN Hz

20079037

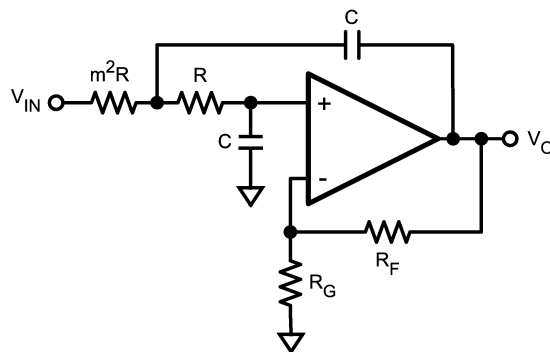

20079038

Sallen Key Low Pass Filter

Absolute Maximum Ratings (Note 1)

Machine Model

200V

If Military/Aerospace specified devices are required, please contact the National Semiconductor Sales Office/Distributors for availability and specifications.

V_S ($V^+ - V^-$)	±6.6V
I_{OUT}	(Note 3)
Common Mode Input Voltage	V^+ to V^-
Maximum Junction Temperature	+150°C
Storage Temperature Range	-65°C to +150°C
Lead Temperature Range	+300°C
ESD Tolerance (Note 4)	
Human Body Model	2000V

Operating Ratings (Note 3)

Thermal Resistance		
Package	(θ_{JC})	(θ_{JA})
8-Pin SOIC	65°C/W	145°C/W
5-Pin SOT23	120°C/W	187°C/W
Operating Temperature	-40°C	+85°C
Nominal Supply Voltage	±3.3V	±6V
(Note 6)		

±5V Electrical Characteristics

Unless specified, $A_V = +2$, $R_F = 250\Omega$; $V_S = \pm 5V$, $R_L = 100\Omega$; unless otherwise specified. **Boldface** limits apply over temperature range. (Note 2)

Symbol	Parameter	Conditions	Min	Typ	Max	Units
Frequency Domain Response						
SSBW	-3dB Bandwidth	$V_{OUT} = 0.5V_{PP}$		260		MHz
LSBW	-3dB Bandwidth	$V_{OUT} = 4.0V_{PP}$	150	170		MHz
SSBWG1	-3dB Bandwidth $A_V = 1$	$V_{OUT} = 0.25V_{PP}$		900		MHz
GFP	.1dB Bandwidth	Gain is Flat to .1dB		130		MHz
DG	Differential Gain	$R_L = 150\Omega$, 4.43MHz		0.01		%
DP	Differential Phase	$R_L = 150\Omega$, 4.43MHz		0.026		deg
Time Domain Response						
TRS	Rise and Fall Time	1V Step		1.6		ns
TRL		4V Step		2.6		ns
t_s	Settling Time to 0.05%	2V Step		15		ns
SR	Slew Rate	4V Step (Note 5)	1200	1400		V/ μ s
Distortion and Noise Response						
HD2	2 nd Harmonic Distortion	$2V_{PP}$, 20MHz		-63		dBc
HD3	3 rd Harmonic Distortion	$2V_{PP}$, 20MHz		-57		dBc
	Equivalent Input Noise					
VN	Voltage Noise	>1MHz		3.1		nV/ $\sqrt{\text{Hz}}$
CN	Current Noise	>1MHz		1.6		pA/ $\sqrt{\text{Hz}}$
Static, DC Performance						
V_{IO}	Input Offset Voltage			±0.8	±2.5 ±3.5	mV
I_{BN}	Input Bias Current			-2	±5 ±8	μ A
I_{BI}	Input Offset Current			.1	±1.5 ±3	μ A
PSRR	Power Supply Rejection Ratio	DC, 1V Step	67 65	73		dB
CMRR	Common Mode Rejection Ratio	DC, 2V Step	67 65	73		dB
I_{CC}	Supply Current	$R_L = \infty$		7.0	7.8 8.5	mA
Miscellaneous Performance						
R_{IN}	Input Resistance			1		M Ω
C_{IN}	Input Capacitance			1.2		pF
R_{OUT}	Output Resistance	Closed Loop		0.3		Ω

±5V Electrical Characteristics (Continued)

Unless specified, $A_V = +2$, $R_F = 250\Omega$; $V_S = \pm 5V$, $R_L = 100\Omega$; unless otherwise specified. **Boldface** limits apply over temperature Range. (Note 2)

Symbol	Parameter	Conditions	Min	Typ	Max	Units
V_O	Output Voltage Range	$R_L = \infty$	± 3.6 ± 3.3	± 3.9		V
V_{OL}		$R_L = 100\Omega$	± 3.2 ± 3.0	± 3.5		V
CMIR	Input Voltage Range	Common Mode, CMRR > 60dB	± 2.8 ± 2.5	± 3.0		V
I_O	Linear Output Current	V_{OUT}	± 60 ± 50	± 90		mA

±3.3V Electrical Characteristics

Unless specified, $A_V = +2$, $R_F = 250\Omega$; $V_S = \pm 3.3V$, $R_L = 100\Omega$; unless otherwise specified. **Boldface** limits apply over temperature Range. (Note 2)

Symbol	Parameter	Conditions	Min	Typ	Max	Units
Frequency Domain Response						
SSBW	-3dB Bandwidth	$V_{OUT} = 0.5V_{PP}$		180		MHz
LSBW	-3dB Bandwidth	$V_{OUT} = 3.0V_{PP}$		110		MHz
SSBWG1	-3dB Bandwidth $A_V = 1$	$V_{OUT} = 0.25V_{PP}$		450		MHz
GFP	.1dB Bandwidth	$V_{OUT} = 1V_{PP}$		40		MHz
DG	Differential Gain	$R_L = 150\Omega$, 4.43MHz		.01		%
DP	Differential Phase	$R_L = 150\Omega$, 4.43MHz		.06		deg
Time Domain Response						
TRL		1V Step		2.2		ns
SR	Slew Rate	2V Step (Note 5)		800		V/ μ s
Distortion and Noise Response						
HD2	2 nd Harmonic Distortion	$2V_{PP}$, 20MHz		-63		dBc
HD3	3 rd Harmonic Distortion	$2V_{PP}$, 20MHz		-43		dBc
	Equivalent Input Noise					
VN	Voltage Noise	>1MHz		3.7		nV/ $\sqrt{\text{Hz}}$
CN	Current Noise	>1MHz		1.1		pA/ $\sqrt{\text{Hz}}$
Static, DC Performance						
V_{IO}	Input Offset Voltage			0.8	± 2.5 ± 3.5	mV
I_{BN}	Input Bias Current			-1	± 3 ± 6	μ A
I_{BI}	Input Offset Current			0	± 1.5 ± 3	μ A
PSRR	Power Supply Rejection Ratio	DC, .5V Step	67	73		dB
CMRR	Common Mode Rejection Ratio	DC, 1V Step	67	75		dB
I_{CC}	Supply Current	$R_L = \infty$		3.6	5 6	mA
Miscellaneous Performance						
R_{OUT}	Input Resistance	Close Loop		.05		Ω
V_O	Output Voltage Range	$R_L = \infty$	± 2.1	± 2.3		V
V_{OL}		$R_L = 100\Omega$	± 1.9	± 2.0		V
CMIR	Input Voltage Range	Common Mode		± 1.3		V
I_O	Linear Output Current	V_{OUT}	± 30	± 45		mA

±3.3V Electrical Characteristics (Continued)

Note 1: Absolute Maximum Ratings indicate limits beyond which damage to the device may occur. Operating Ratings indicate conditions for which the device is intended to be functional, but specific performance is not guaranteed. For guaranteed specifications, see the Electrical Characteristics tables.

Note 2: Electrical Table values apply only for factory testing conditions at the temperature indicated. Factory testing conditions result in very limited self-heating of the device such that $T_J = T_A$. No guarantee of parametric performance is indicated in the electrical tables under conditions of internal self heating where $T_J > T_A$. See Applications Section for information on temperature derating of this device. Min/Max ratings are based on product characterization and simulation. Individual parameters are tested as noted.

Note 3: The maximum output current (I_{OUT}) is determined by device power dissipation limitations. See the Power Dissipation section of the Application Section for more details.

Note 4: Human body model, 1.5kΩ in series with 100pF. Machine model, 0Ω in series with 200pF.

Note 5: rate is Average of Rising and Falling 40-60% slew rates.

Note 6: Nominal Supply voltage range is for supplies with regulation of 10% or better.

Connection Diagrams

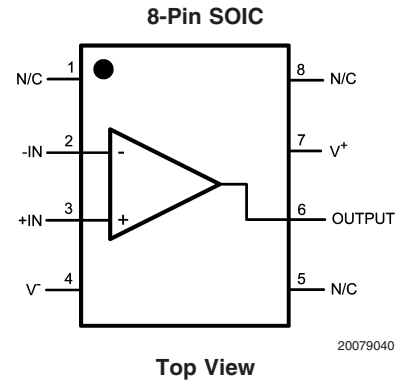
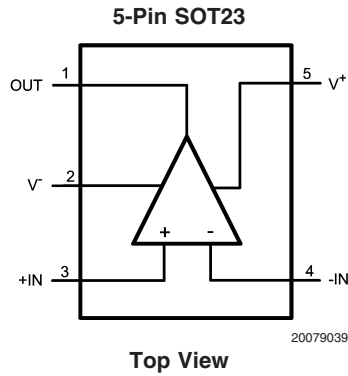

Ordering Information

Package	Part Number	Package Marking	Transport Media	NSC Drawing
8-Pin SOIC	LMH6609MA	LMH6609MA	95 Units/Rails	M08A
	LMH6609MAX		2.5k Units Tape and Reel	
5-SOT23	LMH6609MF	A89A	1k Units Tape and Reel	MF05A
	LMH6609MFX		2.5k Units Tape and Reel	

Typical Performance Characteristics

Small Signal Non-Inverting Frequency Response

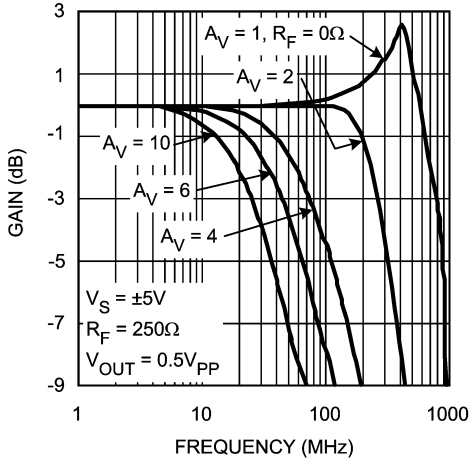

Large Signal Non-Inverting Frequency Response

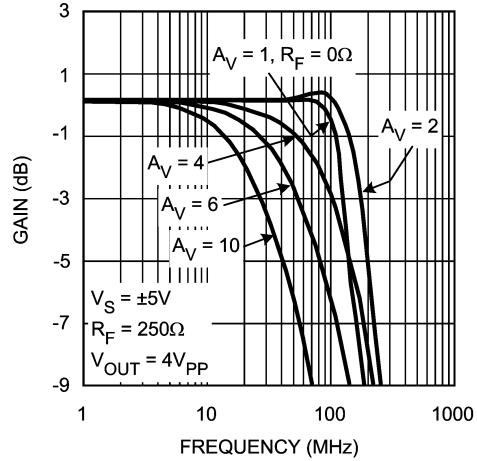

Small Signal Inverting Frequency Response

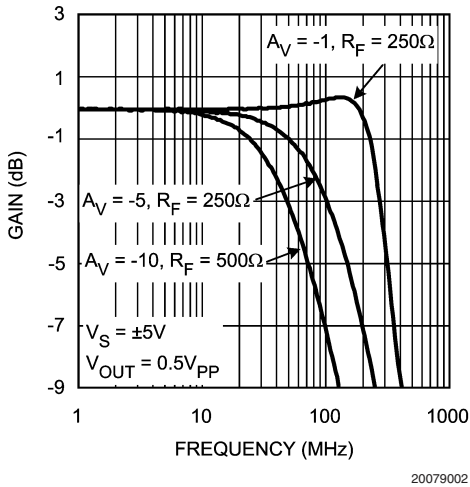

Large Signal Inverting Frequency Response

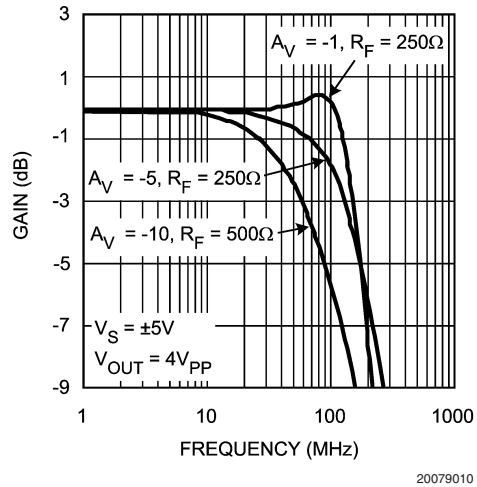

Frequency Response vs. V_{OUT} $A_V = 2$

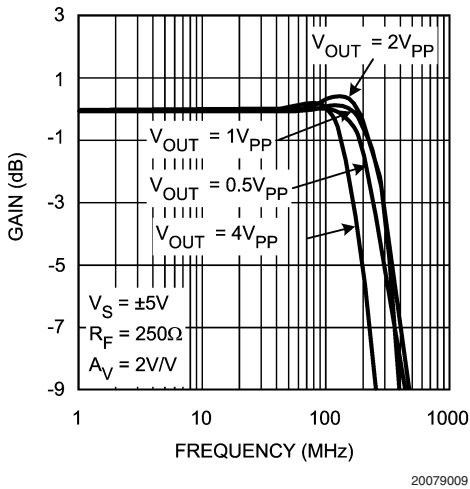

Frequency Response vs. V_{OUT} $A_V = 2$

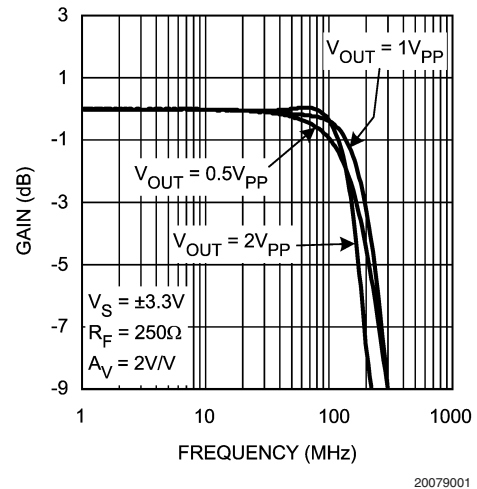

Typical Performance Characteristics (Continued)

Frequency Response vs. V_{OUT} $A_V = 1$

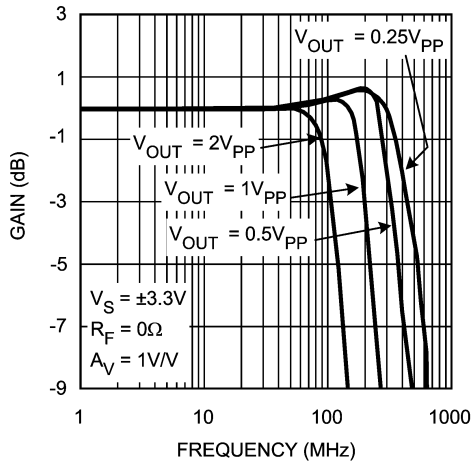

20079007

Frequency Response vs. V_{OUT} $A_V = -1$

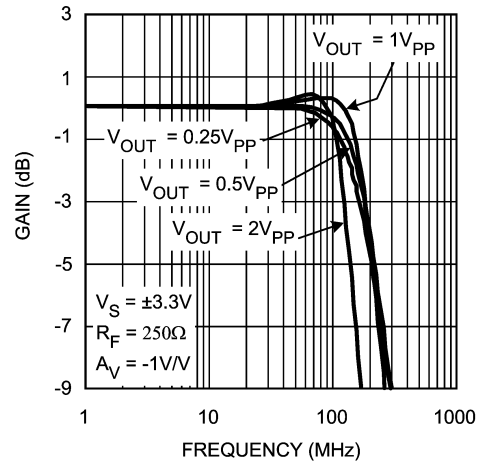

20079008

Frequency Response vs. V_{OUT} $A_V = -1$

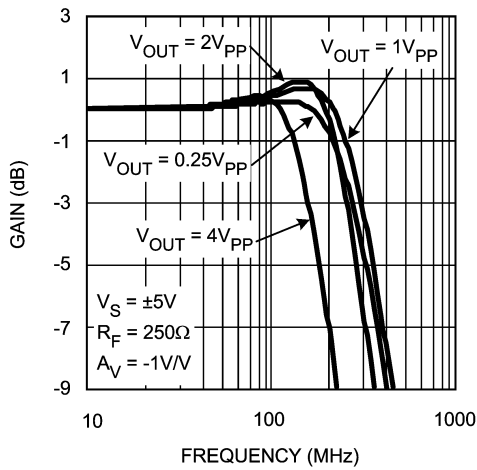

20079006

Frequency Response vs. Cap Load

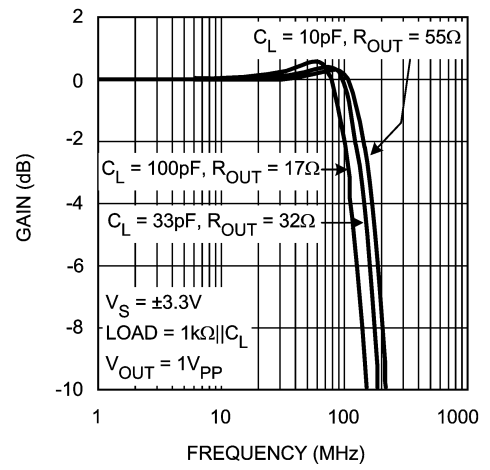

20079042

Frequency Response vs. Cap Load

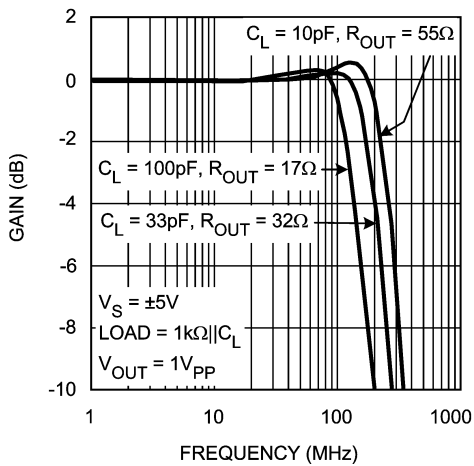

20079043

Suggested R_{OUT} vs. Cap Load

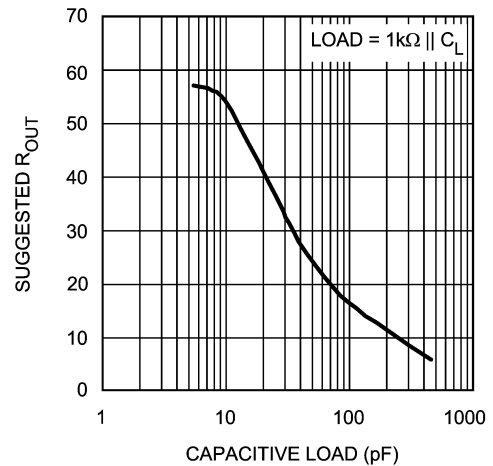

20079041

Typical Performance Characteristics (Continued)

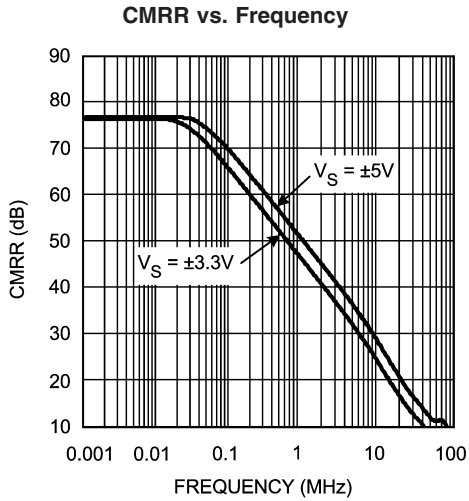

20079011

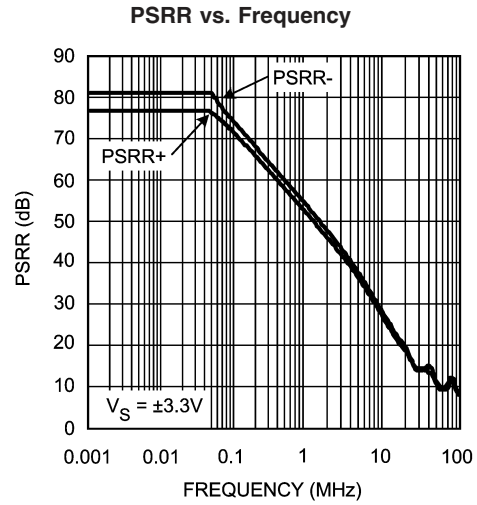

20079012

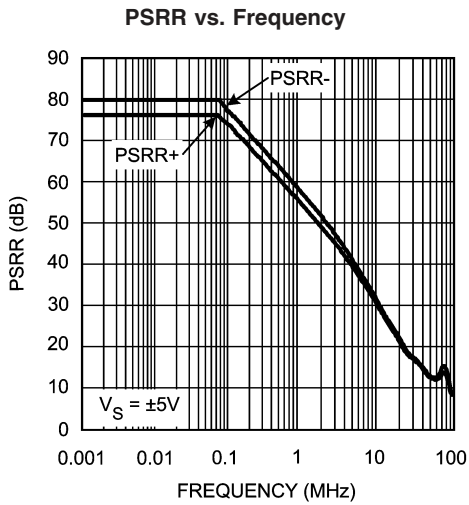

20079013

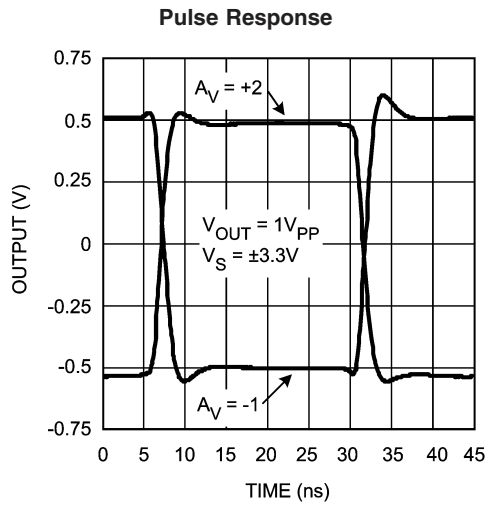

20079016

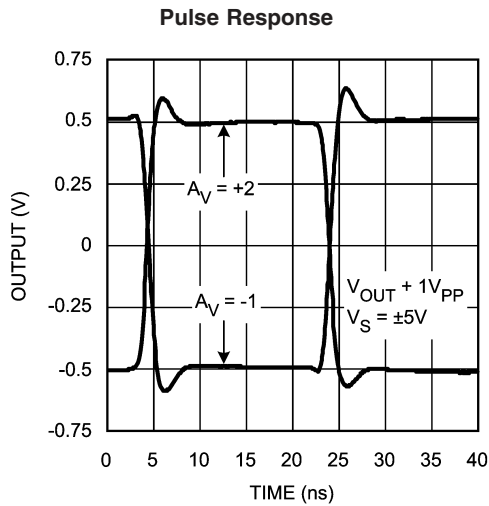

20079014

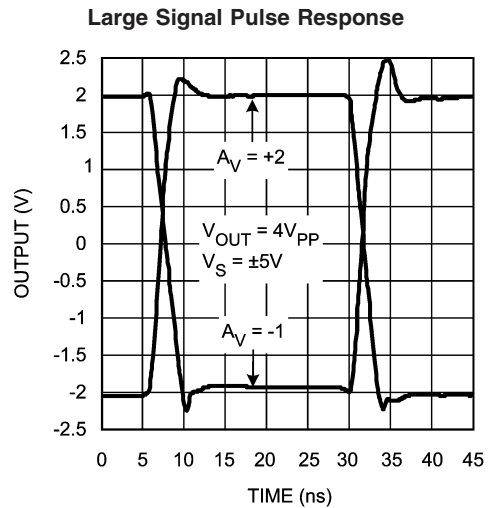

20079015

Typical Performance Characteristics (Continued)

Noise vs. Frequency

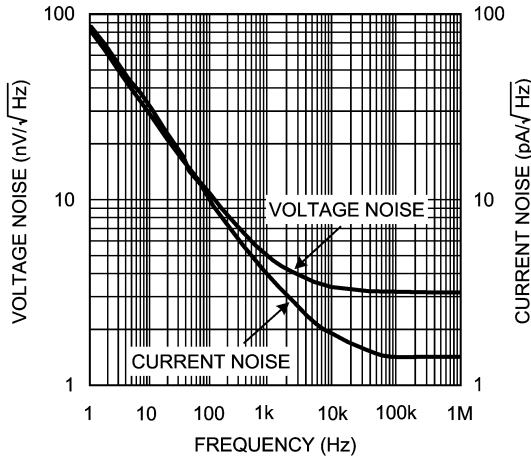

20079025

HD2 vs. V_{OUT}

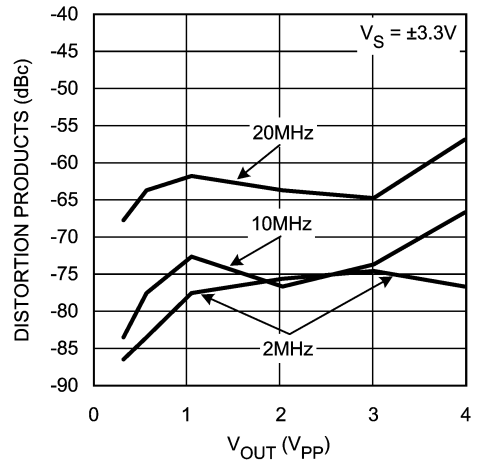

20079018

HD3 vs. V_{OUT}

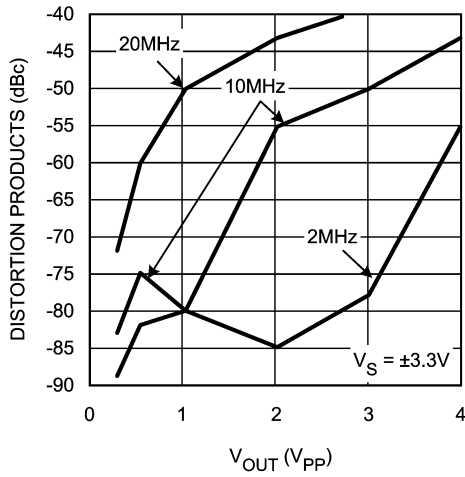

20079017

HD2 vs. V_{OUT}

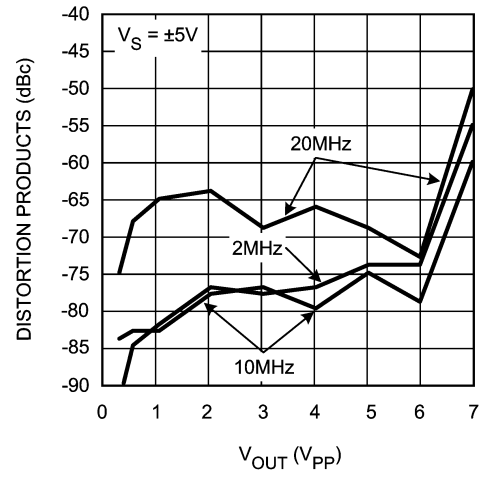

20079020

HD3 vs. V_{OUT}

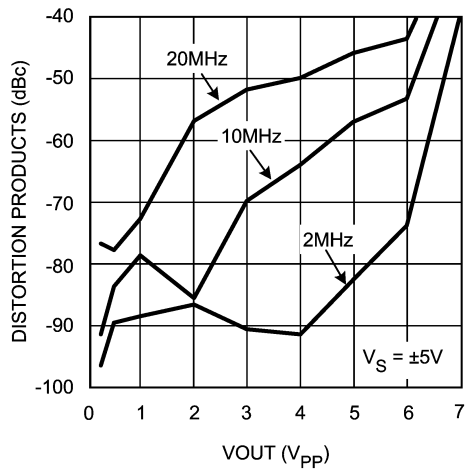

20079019

HD2 & HD3 vs. Frequency

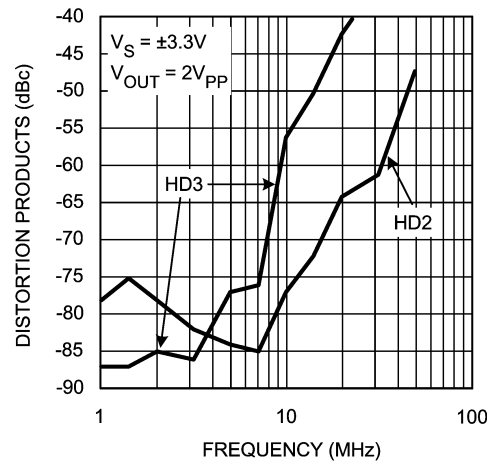

20079021

Typical Performance Characteristics (Continued)

HD2 & HD3 vs. Frequency

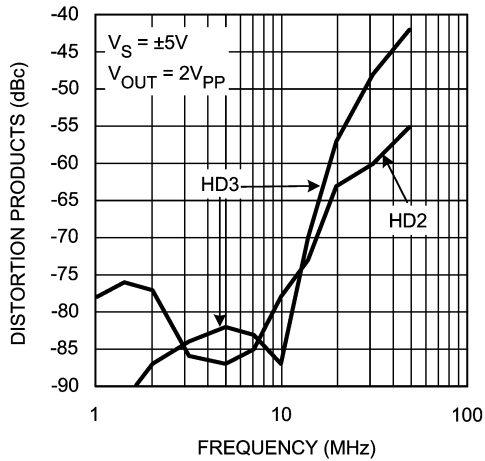

Differential Gain & Phase

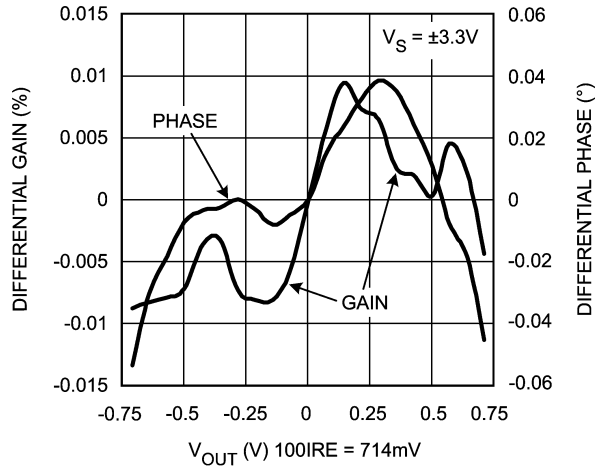

Differential Gain & Phase

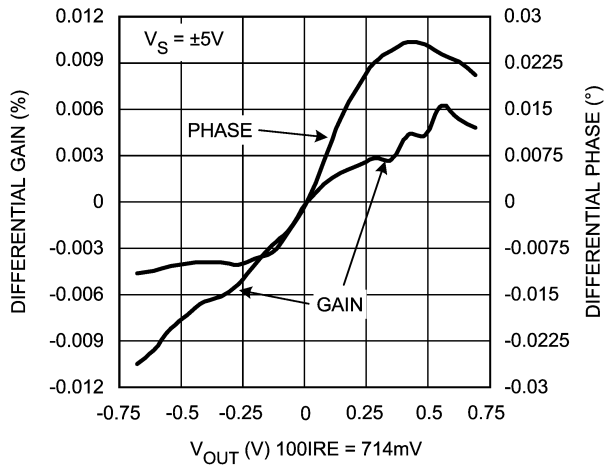

Open Loop Gain & Phase

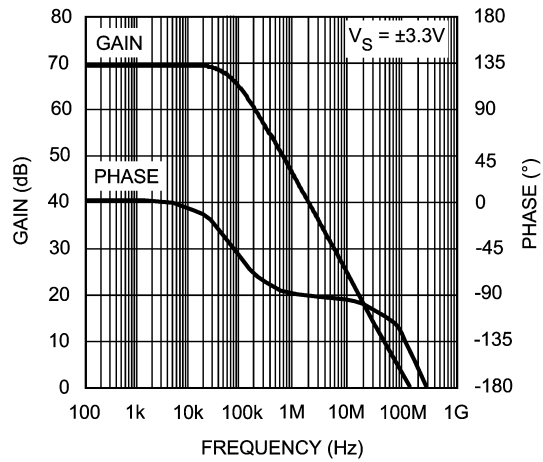

Open Loop Gain & Phase

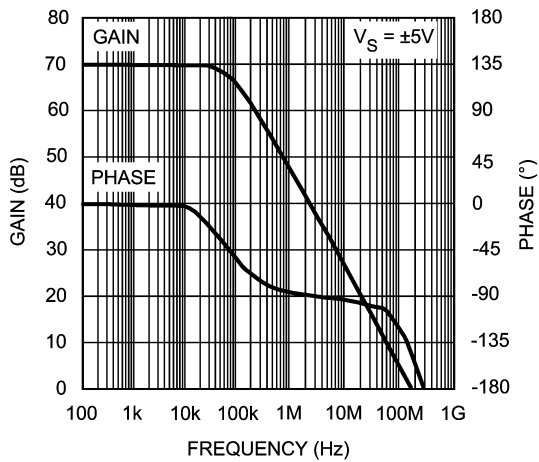

Closed Loop Output Resistance

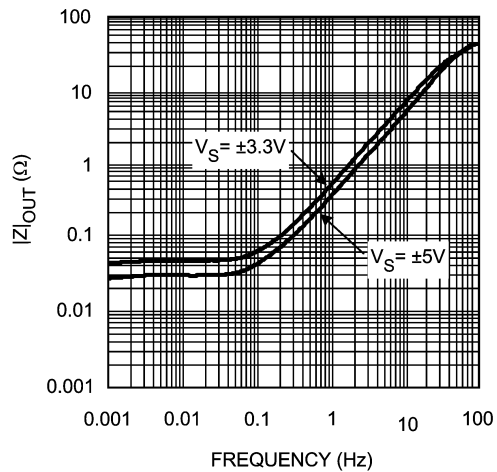

Application Section

GENERAL DESIGN EQUATION

The LMH6609 is a unity gain stable voltage feedback amplifier. The matched input bias currents track well over temperature. This allows the DC offset to be minimized by matching the impedance seen by both inputs.

GAIN

The non-inverting and inverting gain equations for the LMH6609 are as follows:

$$\text{NON-INVERTING GAIN} : 1 + \frac{R_F}{R_G}$$

$$\text{INVERTING GAIN} : - \frac{R_F}{R_G}$$

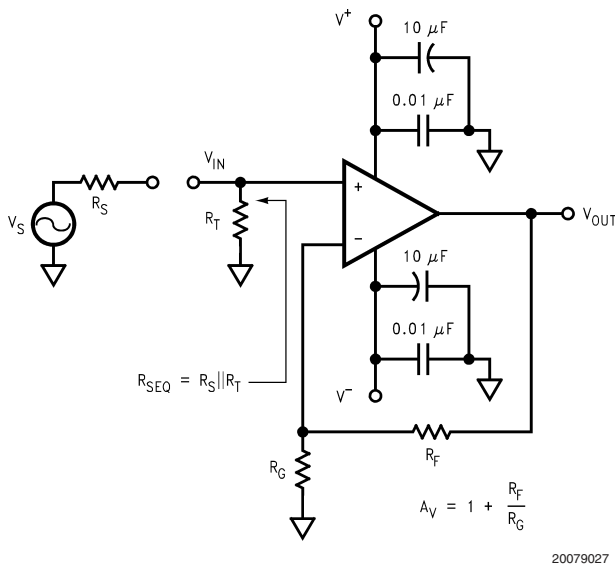

FIGURE 1. Typical Non-Inverting Application

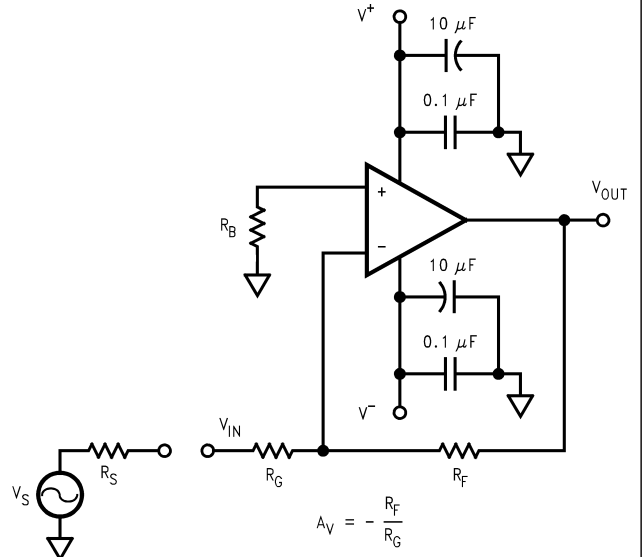

FIGURE 2. Typical Inverting Application

Note: R_B , provides DC bias for non-inverting input.

R_B , R_L and R_T are tied to $V^+/2$ for minimum power consumption and maximum output swing.

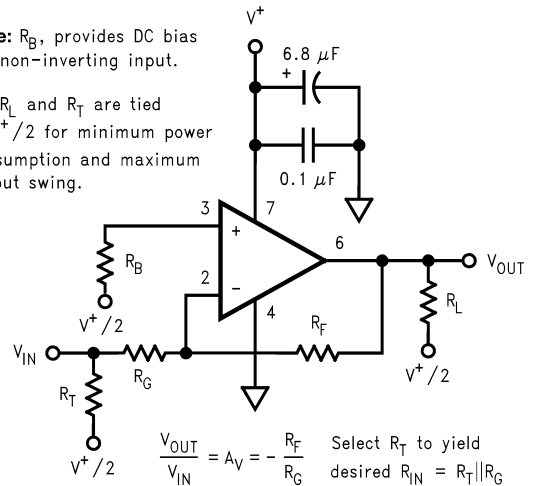

FIGURE 3. Single Supply Inverting

Application Section (Continued)

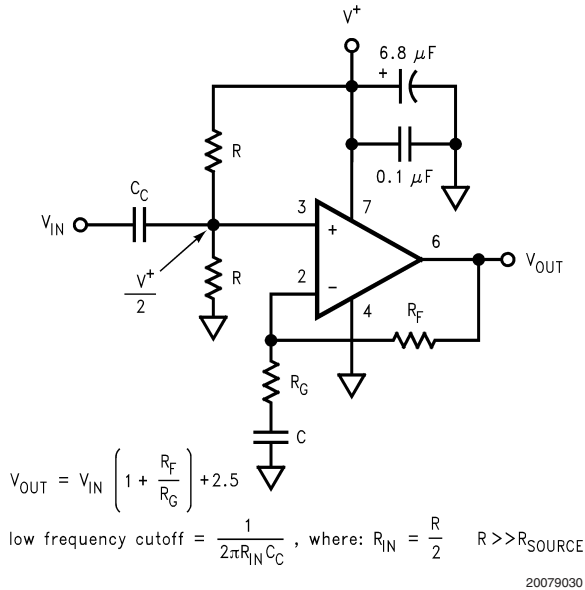

FIGURE 4. AC Coupled Non-Inverting

GAIN BANDWIDTH PRODUCT

The LMH6609 is a voltage feedback amplifier, whose closed-loop bandwidth is approximately equal to the gain-bandwidth product (GBP) divided by the gain (A_V). For gains greater than 5, A_V sets the closed-loop bandwidth of the LMH6609.

$$\text{CLOSED LOOP BANDWIDTH} = \frac{\text{GBP}}{A_V}$$

$$A_V = \frac{(R_F + R_G)}{R_G}$$

$$\text{GBP} = 240\text{MHz}$$

20079031

For Gains less than 5, refer to the frequency response plots to determine maximum bandwidth. For large signal bandwidth the slew rate is a more accurate predictor of bandwidth.

$$f_{MAX} = \frac{S_R}{2\pi V_P}$$

20079032

Where f_{MAX} = bandwidth, S_R = Slew rate and V_P = peak amplitude.

OUTPUT DRIVE AND SETTling TIME PERFORMANCE

The LMH6609 has large output current capability. The 100mA of output current makes the LMH6609 an excellent choice for applications such as:

- Video Line Drivers
- Distribution Amplifiers

When driving a capacitive load or coaxial cable, include a series resistance R_{OUT} to back match or improve settling

time. Refer to the Driving Capacitive Loads section for guidance on selecting an output resistor for driving capacitive loads.

EVALUATION BOARDS

National Semiconductor provides the following evaluation boards as a guide for high frequency layout and as an aid in device testing and characterization. Many of the datasheet plots were measured with these boards.

Device	Package	Board Part #
LMH6609MA	SOIC	CLC730227
LMH6609MF	SOT-23	CLC730216

A free evaluation board is automatically shipped when a sample request is placed with National Semiconductor.

CIRCUIT LAYOUT CONSIDERATION

A proper printed circuit layout is essential for achieving high frequency performance. National provides evaluation boards for the LMH6609 as shown above. These boards were laid out for optimum, high-speed performance. The ground plane was removed near the input and output pins to reduce parasitic capacitance. Also, all trace lengths were minimized to reduce series inductances.

Supply bypassing is required for the amplifiers performance. The bypass capacitors provide a low impedance return current path at the supply pins. They also provide high frequency filtering on the power supply traces. 10μF tantalum and .01μF capacitors are recommended on both supplies (from supply to ground). In addition a .1μF ceramic capacitor can be added from V^+ to V^- to aid in second harmonic suppression.

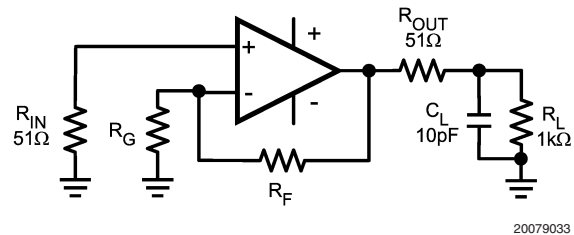

FIGURE 5. Driving Capacitive Loads with R_{OUT} for Improved Stability

DRIVING CAPACITIVE LOADS

Capacitive output loading applications will benefit from the use of a series output resistor R_{OUT} . Figure 5 shows the use of a series output resistor, R_{OUT} as it might be applied when driving an analog to digital converter. The charts "Suggested R_O vs. Cap Load" in the Typical Performance Section give a recommended value for mitigating capacitive loads. The values suggested in the charts are selected for .5dB or less of peaking in the frequency response. This gives a good compromise between settling time and bandwidth. For applications where maximum frequency response is needed and some peaking is tolerable, the value of R_O can be reduced slightly from the recommended values. There will be amplitude lost in the series resistor unless the gain is adjusted to compensate; this effect is most noticeable with heavy resistive loads.

Application Section (Continued)

COMPONENT SELECTION AND FEEDBACK RESISTOR

Surface mount components are highly recommended for the LMH6609. Leaded components will introduce unpredictable parasitic loading that will interfere with proper device operation. Do not use wire wound resistors.

The LMH6609 operates best with a feedback resistor of approximately 250Ω for all gains of +2 and greater and for -1 and less. With lower gains in particular, large value feedback resistors will exaggerate the effects of parasitic capacitances and may lead to ringing on the pulse response and frequency response peaking. Large value resistors also add undesirable thermal noise. Feedback resistors that are much below 100Ω will load the output stage, which will reduce voltage output swing, increase device power dissipation, increase distortion and reduce current available for driving the load.

In the buffer configuration the output should be shorted directly to the inverting input. This feedback does not load the output stage because the inverting input is a high impedance point and there is no gain set resistor to ground.

OPTIMIZING DC ACCURACY

The LMH6609 offers excellent DC accuracy. The well-matched inputs of this amplifier allows even better performance if care is taken to balance the impedances seen by the two inputs. The parallel combination of the gain setting R_G and feedback R_F resistors should be equal to R_{SEQ} , the resistance of the source driving the op amp in parallel with any terminating Resistor (See *Figure 1*). Combining this with the non inverting gain equation gives the following parameters:

$$R_F = A_V R_{SEQ}$$

$$R_G = R_F / (A_V - 1)$$

For Inverting gains the bias current cancellation is accomplished by placing a resistor R_B on the non-inverting input equal in value to the resistance seen by the inverting input (See *Figure 2*). $R_B = R_F \parallel (R_G + R_S)$

The additional noise contribution of R_B can be minimized by the use of a shunt capacitor (not shown).

POWER DISSIPATION

The LMH6609 has the ability to drive large currents into low impedance loads. Some combinations of ambient temperature and device loading could result in device overheating. For most conditions peak power values are not as important as RMS powers. To determine the maximum allowable power dissipation for the LMH6609 use the following formula:

$$P_{MAX} = (150^\circ - T_{AMB}) / \theta_{JA}$$

Where T_{AMB} = Ambient temperature ($^\circ\text{C}$) and θ_{JA} = Thermal resistance, from junction to ambient, for a given package ($^\circ\text{C}/\text{W}$). For the SOIC package θ_{JA} is $148^\circ\text{C}/\text{W}$, for the SOT it is $250^\circ\text{C}/\text{W}$. 150°C is the absolute maximum limit for the internal temperature of the device.

Either forced air cooling or a heat sink can greatly increase the power handling capability for the LMH6609.

VIDEO PERFORMANCE

The LMH6609 has been designed to provide good performance with both PAL and NTSC composite video signals. The LMH6609 is specified for PAL signals. NTSC performance is typically marginally better due to the lower fre-

quency content of the signal. Performance degrades as the loading is increased, therefore best performance will be obtained with back-terminated loads. The back termination reduces reflections from the transmission line and effectively masks transmission line and other parasitic capacitances from the amplifier output stage. This means that the device should be configured for a gain of 2 in order to have a net gain of 1 after the terminating resistor. (See *Figure 6*)

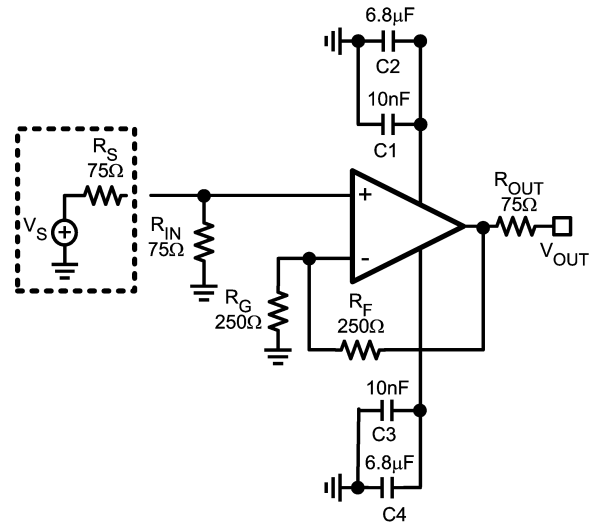

20079034

FIGURE 6. Typical Video Application

ESD PROTECTION

The LMH6609 is protected against electrostatic discharge (ESD) on all pins. The LMH6609 will survive 2000V Human Body model or 200V Machine model events.

Under closed loop operation the ESD diodes have no effect on circuit performance. There are occasions, however, when the ESD diodes may be evident. For instance, if the amplifier is powered down and a large input signal is applied the ESD diodes will conduct.

TRANSIMPEDANCE AMPLIFIER

The low input current noise and unity gain stability of the LMH6609 make it an excellent choice for transimpedance applications. *Figure 7* illustrates a low noise transimpedance amplifier that is commonly implemented with photo diodes. R_F sets the transimpedance gain. The photo diode current multiplied by R_F determines the output voltage.

Application Section (Continued)

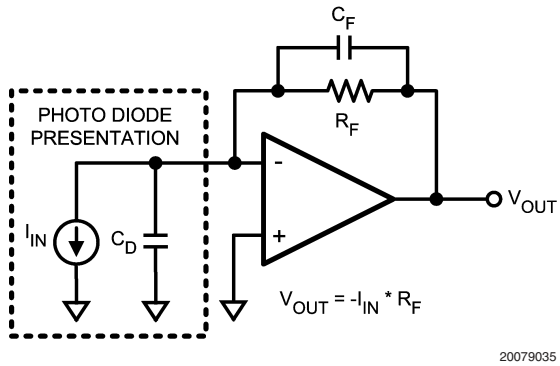

FIGURE 7. Transimpedance Amplifier

The capacitances are defined as:

- C_D = Equivalent Diode Capacitance
- C_F = Feedback Capacitance

The feedback capacitor is used to give optimum flatness and stability. As a starting point the feedback capacitance should be chosen as $\frac{1}{2}$ of the Diode capacitance. Lower feedback capacitors will peak frequency response.

Rectifier

The large bandwidth of the LMH6609 allows for high-speed rectification. A common rectifier topology is shown in *Figure 8*. R_1 and R_2 set the gain of the rectifier.

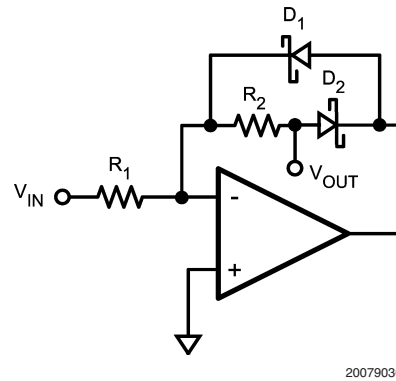
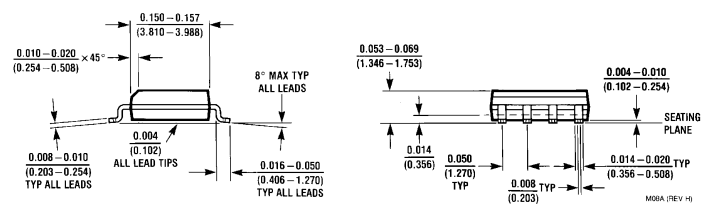
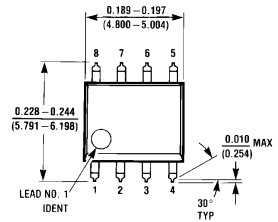
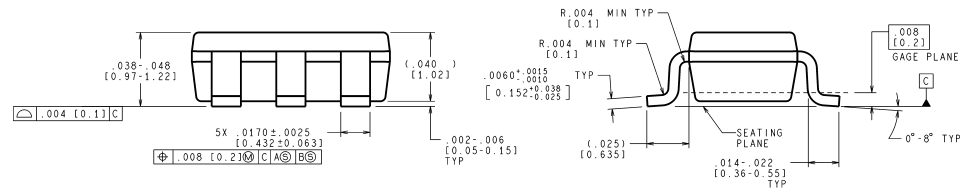
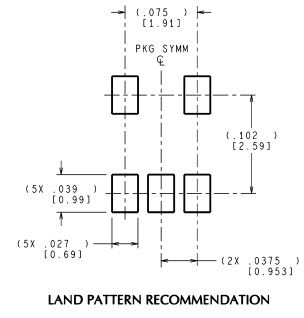
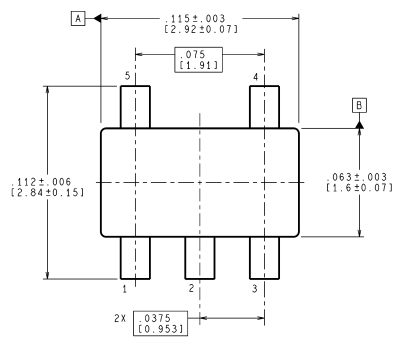

FIGURE 8. Rectifier Topology

Physical Dimensions inches (millimeters)
unless otherwise noted



8-Pin SOIC
NS Product Number M08A



CONTROLLING DIMENSION IS INCH
VALUES IN [] ARE MILLIMETERS

5-Pin SOT23
NS Product Number MF05A

MF05A (Rev B)

Notes

LIFE SUPPORT POLICY

NATIONAL'S PRODUCTS ARE NOT AUTHORIZED FOR USE AS CRITICAL COMPONENTS IN LIFE SUPPORT DEVICES OR SYSTEMS WITHOUT THE EXPRESS WRITTEN APPROVAL OF THE PRESIDENT AND GENERAL COUNSEL OF NATIONAL SEMICONDUCTOR CORPORATION. As used herein:

1. Life support devices or systems are devices or systems which, (a) are intended for surgical implant into the body, or (b) support or sustain life, and whose failure to perform when properly used in accordance with instructions for use provided in the labeling, can be reasonably expected to result in a significant injury to the user.
2. A critical component is any component of a life support device or system whose failure to perform can be reasonably expected to cause the failure of the life support device or system, or to affect its safety or effectiveness.



National Semiconductor
Americas Customer
Support Center
Email: new.feedback@nsc.com
Tel: 1-800-272-9959

www.national.com

National Semiconductor
Europe Customer Support Center
Fax: +49 (0) 180-530 85 86
Email: europe.support@nsc.com
Deutsch Tel: +49 (0) 69 9508 6208
English Tel: +44 (0) 870 24 0 2171
Français Tel: +33 (0) 1 41 91 8790

National Semiconductor
Asia Pacific Customer
Support Center
Email: ap.support@nsc.com

National Semiconductor
Japan Customer Support Center
Fax: 81-3-5639-7507
Email: jpn.feedback@nsc.com
Tel: 81-3-5639-7560