

## LMH0074

# SMPTE 259M / 344M Adaptive Cable Equalizer

## General Description

The LMH0074 SMPTE 259M / 344M Adaptive Cable Equalizer is designed to equalize data transmitted over cable (or any media with similar dispersive loss characteristics). The equalizer operates over a wide range of data rates from 125 Mbps to 540 Mbps and supports SMPTE 259M and SMPTE 344M.

The LMH0074 implements DC restoration to correctly handle pathological data conditions. The equalizer may be driven in either a single ended or differential configuration.

Additional features include separate carrier detect and output mute pins which may be tied together to mute the output when no signal is present. A programmable mute reference is provided to mute the output at a selectable level of signal degradation.

## Features

- SMPTE 259M and SMPTE 344M compliant
- Supports DVB-ASI at 270 Mbps
- Data rates: 125 Mbps to 540 Mbps
- Equalizes up to 400 meters of Belden 1694A at 270 Mbps
- Manual bypass and output mute with a programmable threshold
- Single-ended or differential input
- 50Ω differential outputs
- Single 3.3V supply operation
- Industrial temperature range: -40°C to +85°C
- 208mW typical power consumption with 3.3V supply
- Footprint compatible with the LMH0044 and the GS9074A

## Applications

- SMPTE 259M and SMPTE 344M serial digital interfaces
- Serial digital data equalization and reception
- Data recovery equalization

## Typical Application

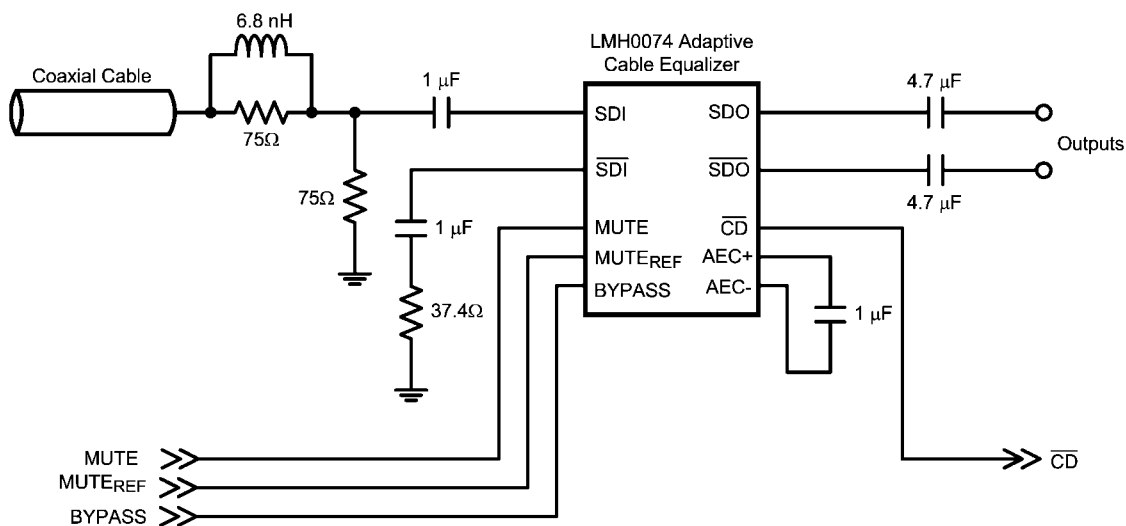

30027501

## Absolute Maximum Ratings *(Note 1)*

Supply Voltage	-0.5V to 3.6V
Input Voltage (all inputs)	-0.3V to $V_{CC}+0.3V$
Storage Temperature Range	-65°C to +150°C
Junction Temperature	+150°C
Lead Temperature (Soldering 4 Sec)	+260°C
Package Thermal Resistance	
$\theta_{JA}$ 16-pin LLP	+43°C/W
$\theta_{JC}$ 16-pin LLP	+9°C/W
ESD Rating (HBM)	8kV
ESD Rating (MM)	250V

## Recommended Operating Conditions

Supply Voltage ( $V_{CC} - V_{EE}$ )	3.3V $\pm$ 5%
Input Coupling Capacitance	1.0 $\mu$ F
AEC Capacitor (Connected between AEC+ and AEC-)	1.0 $\mu$ F
Operating Free Air Temperature ( $T_A$ )	-40°C to +85°C

## DC Electrical Characteristics

Over Supply Voltage and Operating Temperature ranges, unless otherwise specified *(Notes 2, 3)*.

Symbol	Parameter	Conditions	Reference	Min	Typ	Max	Units
$V_{CMIN}$	Input Common Mode Voltage		SDI, $\overline{SDI}$		1.9		V
$V_{SDI}$	Input Voltage Swing	At LMH0074 input, <i>(Notes 4, 6)</i>		720	800	950	mV <sub>P-P</sub>
$V_{CMOUT}$	Output Common Mode Voltage		SDO, $\overline{SDO}$		$V_{CC} - V_{SDO}/2$		V
$V_{SDO}$	Output Voltage Swing	50 $\Omega$ load, differential			750		mV <sub>P-P</sub>
	MUTE <sub>REF</sub> DC Voltage (floating)		MUTE <sub>REF</sub>		1.3		V
	MUTE <sub>REF</sub> Range				0.7		V
	$\overline{CD}$ Output Voltage	Carrier not present	$\overline{CD}$	2.6			V
		Carrier present				0.4	V
	MUTE Input Voltage	Min to mute outputs	MUTE	3.0			V
		Max to force outputs active				0.8	V
$I_{CC}$	Supply Current	<i>(Note 7)</i>			63	77	mA

## AC Electrical Characteristics

Over Supply Voltage and Operating Temperature ranges, unless otherwise specified (*Note 3*).

Symbol	Parameter	Conditions	Reference	Min	Typ	Max	Units
$BR_{MIN}$	Minimum Input Data Rate		SDI, $SD\bar{I}$		125		Mbps
$BR_{MAX}$	Maximum Input Data Rate					540	Mbps
	Jitter for various Cable Lengths (with equalizer pathological)	270 Mbps, Belden 1694A, 400 meters ( <i>Note 4</i> )			0.2		UI
		270 Mbps, Belden 8281, 280 meters ( <i>Note 4</i> )			0.2		UI
$t_r, t_f$	Output Rise Time, Fall Time	20% – 80%, ( <i>Note 4</i> )	SDO, $SD\bar{O}$		100	220	ps
	Mismatch in Rise/Fall Time	( <i>Note 4</i> )			2	15	ps
$t_{OS}$	Output Overshoot	( <i>Note 4</i> )			1	5	%
$R_{OUT}$	Output Resistance	single-ended, ( <i>Note 5</i> )			50		$\Omega$
$RL_{IN}$	Input Return Loss	( <i>Note 8</i> )	SDI, $SD\bar{I}$	15	18-20		dB
$R_{IN}$	Input Resistance	single-ended			1.3		$k\Omega$
$C_{IN}$	Input Capacitance	single-ended, ( <i>Note 5</i> )			1		pF

**Note 1:** "Absolute Maximum Ratings" are those parameter values beyond which the life and operation of the device cannot be guaranteed. The stating herein of these maximums shall not be construed to imply that the device can or should be operated at or beyond these values. The table of "Electrical Characteristics" specifies acceptable device operating conditions.

**Note 2:** Current flow into device pins is defined as positive. Current flow out of device pins is defined as negative. All voltages are stated referenced to  $V_{EE} = 0$  Volts.

**Note 3:** Typical values are stated for  $V_{CC} = +3.3V$  and  $T_A = +25^\circ C$ .

**Note 4:** Specification is guaranteed by characterization.

**Note 5:** Specification is guaranteed by design.

**Note 6:** The maximum input voltage swing assumes a nonstressing, DC-balance signal; specifically, the SMPTE-recommended color bar test signal. Pathological or other stressing signals may not be used. This specification is for 0m cable only.

**Note 7:** Supply current depends on the amount of cable being equalized. The current is highest for short cable and decreases as the cable length is increased. Refer to [Figure 1](#).

**Note 8:** Input return loss is dependent on board design. The LMH0074 meets this specification on the SD074 evaluation board from 5MHz to 1.5GHz.

## Connection Diagram

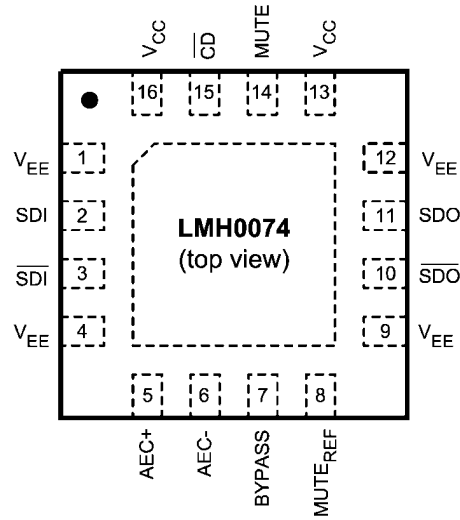

30027503

**16-Pin LLP**  
**Order Number LMH0074SQ**  
**See NS Package Number SQB16A**

## Pin Descriptions

Pin #	Name	Description
1	$V_{EE}$	Negative power supply (ground).
2	SDI	Serial data true input.
3	$\overline{\text{SDI}}$	Serial data complement input.
4	$V_{EE}$	Negative power supply (ground).
5	AEC+	AEC loop filter external capacitor (1 $\mu$ F) positive connection.
6	AEC-	AEC loop filter external capacitor (1 $\mu$ F) negative connection.
7	BYPASS	Bypasses equalization and DC restoration when high. No equalization occurs in this mode.
8	$\text{MUTE}_{\text{REF}}$	Mute reference. Sets the threshold for $\overline{\text{CD}}$ and (with $\overline{\text{CD}}$ tied to MUTE) determines the maximum cable to be equalized before muting. $\text{MUTE}_{\text{REF}}$ may be unconnected for maximum equalization.
9	$V_{EE}$	Negative power supply (ground).
10	$\overline{\text{SDO}}$	Serial data complement output.
11	SDO	Serial data true output.
12	$V_{EE}$	Negative power supply (ground).
13	$V_{CC}$	Positive power supply (+3.3V).
14	MUTE	Output mute. To disable the mute function and enable the output, MUTE must be tied to GND or a low level signal. To force the outputs to a muted state, tie to $V_{CC}$ . $\overline{\text{CD}}$ may be tied to this pin to inhibit the output when no input signal is present. MUTE has no function in BYPASS mode.
15	$\overline{\text{CD}}$	Carrier detect. $\overline{\text{CD}}$ is high when no signal is present. $\overline{\text{CD}}$ has no function in BYPASS mode.
16	$V_{CC}$	Positive power supply (+3.3V).
DAP	$V_{EE}$	Connect exposed DAP to negative power supply.

## Block Diagram

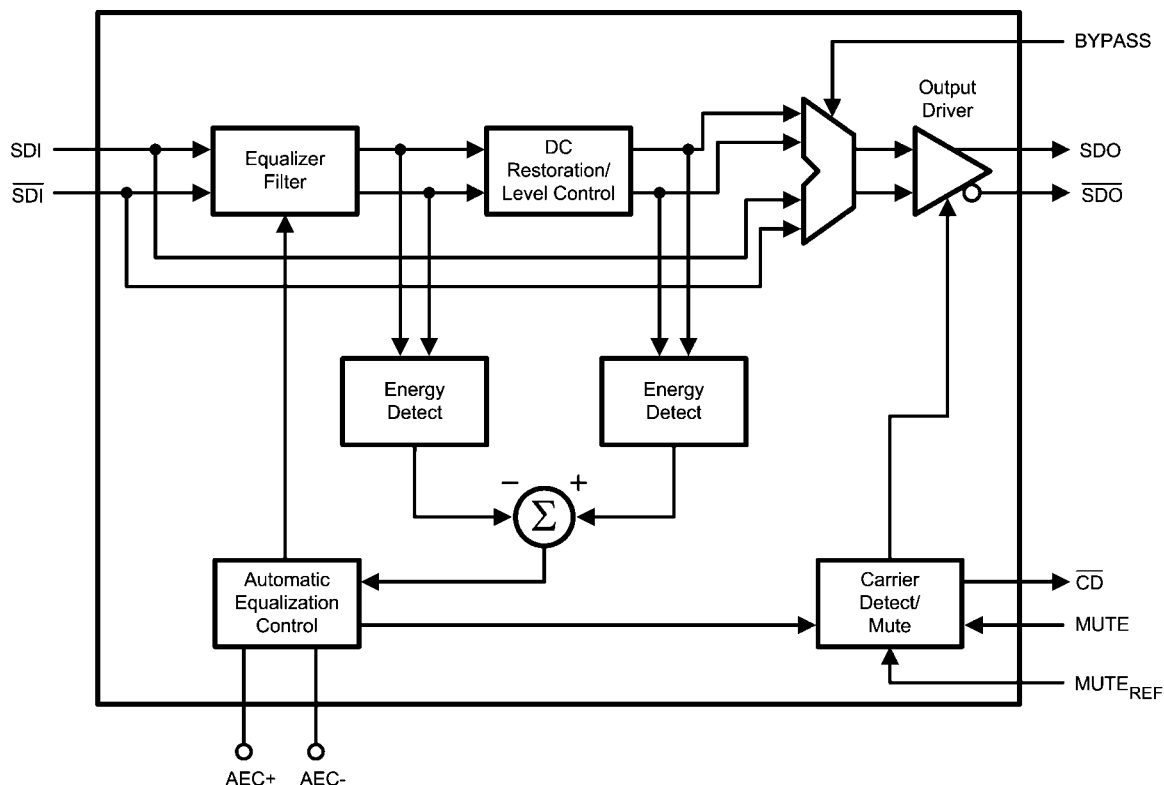

30027502

## Device Operation

### BLOCK DESCRIPTION

The **Equalizer Filter** block is a multi-stage adaptive filter. If Bypass is high, the equalizer filter is disabled.

The **DC Restoration / Level Control** block receives the differential signals from the equalizer filter block. This block incorporates a self-biasing DC restoration circuit to fully DC restore the signals. If Bypass is high, this function is disabled.

The signals before and after the DC Restoration / Level Control block are used to generate the **Automatic Equalization Control (AEC)** signal. This control signal sets the gain and bandwidth of the equalizer filter. The loop response in the AEC block is controlled by an external 1 $\mu$ F capacitor placed across the AEC+ and AEC- pins.

The **Carrier Detect / Mute** block generates the carrier detect signal and controls the mute function of the output. This block utilizes the  $\overline{CD}$  and MUTE signals along with **Mute Reference (MUTE<sub>REF</sub>)**.

The **Output Driver** produces SDO and  $\overline{SDO}$ .

### MUTE REFERENCE (MUTE<sub>REF</sub>)

The mute reference sets the threshold for  $\overline{CD}$  and (with  $\overline{CD}$  tied to MUTE) determines the amount of cable to equalize before automatically muting the outputs. This is set by applying a voltage inversely proportional to the length of cable to equalize. As the applied MUTE<sub>REF</sub> voltage is increased, the amount of cable that can be equalized before carrier detect is

de-asserted and the outputs are muted is decreased. MUTE<sub>REF</sub> may be left unconnected for maximum equalization before muting.

### CARRIER DETECT ( $\overline{CD}$ ) AND MUTE

Carrier detect  $\overline{CD}$  indicates if a valid signal is present at the LMH0074 input. If MUTE<sub>REF</sub> is used, the carrier detect threshold will be altered accordingly.  $\overline{CD}$  provides a high voltage when no signal is present at the LMH0074 input.  $\overline{CD}$  is low when a valid input signal is detected.

MUTE can be used to manually mute or enable SDO and  $\overline{SDO}$ . Applying a high input to MUTE will mute the LMH0074 outputs. Applying a low input will force the outputs to be active.

$\overline{CD}$  and MUTE may be tied together to automatically mute the output when no input signal is present.

### INPUT INTERFACING

The LMH0074 accepts either differential or single-ended input. The input must be AC coupled. Transformer coupling is not supported.

The LMH0074 correctly handles equalizer pathological signals for standard definition digital video, as described in SMPTE RP 178.

### OUTPUT INTERFACING

The SDO and  $\overline{SDO}$  outputs are internally loaded with 50 $\Omega$ . They produce a 750 mV<sub>P-P</sub> differential output, or a 375 mV<sub>P-P</sub> single-ended output.

## Application Information

### PCB LAYOUT RECOMMENDATIONS

Please refer to the following Application Note on National's website: **AN-1372, "LMH0034 PCB Layout Techniques."** The PCB layout techniques in the application note apply to the LMH0074 as well.

### SUPPLY CURRENT VS. CABLE LENGTH

The supply current ( $I_{CC}$ ) depends on the amount of cable being equalized. The current is highest for short cable and decreases as the cable length is increased. *Figure 1* shows supply current vs. Belden 1694A cable length for 270 Mbps data.

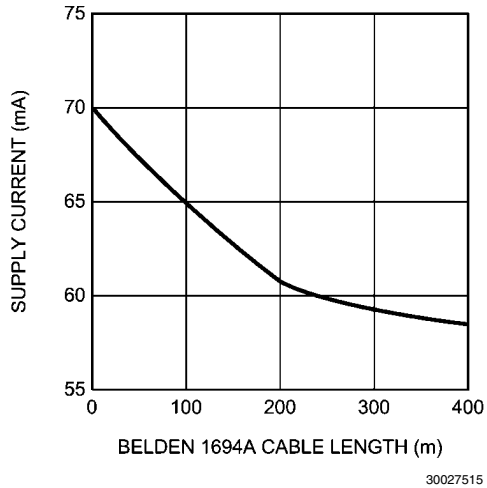

**FIGURE 1. Supply Current vs. Belden 1694A Cable Length, 270 Mbps**

**Physical Dimensions** inches (millimeters) unless otherwise noted

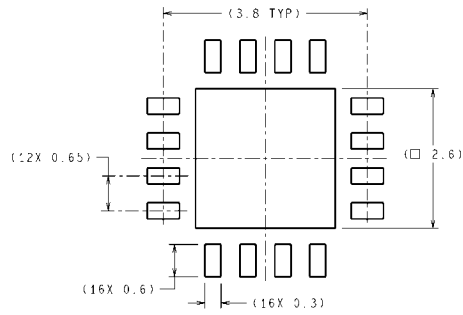

**DIMENSIONS ARE IN MILLIMETERS**  
DIMENSIONS IN ( ) FOR REFERENCE ONLY

**RECOMMENDED LAND PATTERN**

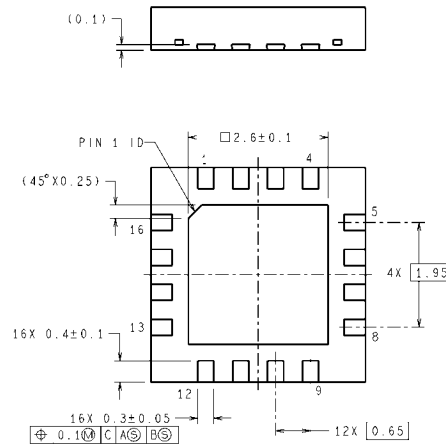
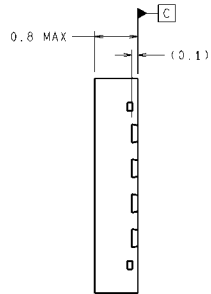
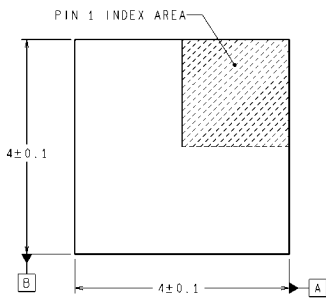

SQB16A (Rev A)

**16-Pin LLP**  
**Order Number LMH0074SQ**  
**NS Package Number SQB16A**

## Notes

For more National Semiconductor product information and proven design tools, visit the following Web sites at:

Products		Design Support	
Amplifiers	<a href="http://www.national.com/amplifiers">www.national.com/amplifiers</a>	WEBENCH® Tools	<a href="http://www.national.com/webench">www.national.com/webench</a>
Audio	<a href="http://www.national.com/audio">www.national.com/audio</a>	App Notes	<a href="http://www.national.com/appnotes">www.national.com/appnotes</a>
Clock and Timing	<a href="http://www.national.com/timing">www.national.com/timing</a>	Reference Designs	<a href="http://www.national.com/refdesigns">www.national.com/refdesigns</a>
Data Converters	<a href="http://www.national.com/adc">www.national.com/adc</a>	Samples	<a href="http://www.national.com/samples">www.national.com/samples</a>
Interface	<a href="http://www.national.com/interface">www.national.com/interface</a>	Eval Boards	<a href="http://www.national.com/evalboards">www.national.com/evalboards</a>
LVDS	<a href="http://www.national.com/lvds">www.national.com/lvds</a>	Packaging	<a href="http://www.national.com/packaging">www.national.com/packaging</a>
Power Management	<a href="http://www.national.com/power">www.national.com/power</a>	Green Compliance	<a href="http://www.national.com/quality/green">www.national.com/quality/green</a>
Switching Regulators	<a href="http://www.national.com/switchers">www.national.com/switchers</a>	Distributors	<a href="http://www.national.com/contacts">www.national.com/contacts</a>
LDOs	<a href="http://www.national.com/ldo">www.national.com/ldo</a>	Quality and Reliability	<a href="http://www.national.com/quality">www.national.com/quality</a>
LED Lighting	<a href="http://www.national.com/led">www.national.com/led</a>	Feedback/Support	<a href="http://www.national.com/feedback">www.national.com/feedback</a>
Voltage Reference	<a href="http://www.national.com/vref">www.national.com/vref</a>	Design Made Easy	<a href="http://www.national.com/easy">www.national.com/easy</a>
PowerWise® Solutions	<a href="http://www.national.com/powerwise">www.national.com/powerwise</a>	Solutions	<a href="http://www.national.com/solutions">www.national.com/solutions</a>
Serial Digital Interface (SDI)	<a href="http://www.national.com/sdi">www.national.com/sdi</a>	Mil/Aero	<a href="http://www.national.com/milaero">www.national.com/milaero</a>
Temperature Sensors	<a href="http://www.national.com/tempensors">www.national.com/tempensors</a>	SolarMagic™	<a href="http://www.national.com/solarmagic">www.national.com/solarmagic</a>
Wireless (PLL/VCO)	<a href="http://www.national.com/wireless">www.national.com/wireless</a>	PowerWise® Design University	<a href="http://www.national.com/training">www.national.com/training</a>

THE CONTENTS OF THIS DOCUMENT ARE PROVIDED IN CONNECTION WITH NATIONAL SEMICONDUCTOR CORPORATION ("NATIONAL") PRODUCTS. NATIONAL MAKES NO REPRESENTATIONS OR WARRANTIES WITH RESPECT TO THE ACCURACY OR COMPLETENESS OF THE CONTENTS OF THIS PUBLICATION AND RESERVES THE RIGHT TO MAKE CHANGES TO SPECIFICATIONS AND PRODUCT DESCRIPTIONS AT ANY TIME WITHOUT NOTICE. NO LICENSE, WHETHER EXPRESS, IMPLIED, ARISING BY ESTOPPEL OR OTHERWISE, TO ANY INTELLECTUAL PROPERTY RIGHTS IS GRANTED BY THIS DOCUMENT.

TESTING AND OTHER QUALITY CONTROLS ARE USED TO THE EXTENT NATIONAL DEEMS NECESSARY TO SUPPORT NATIONAL'S PRODUCT WARRANTY. EXCEPT WHERE MANDATED BY GOVERNMENT REQUIREMENTS, TESTING OF ALL PARAMETERS OF EACH PRODUCT IS NOT NECESSARILY PERFORMED. NATIONAL ASSUMES NO LIABILITY FOR APPLICATIONS ASSISTANCE OR BUYER PRODUCT DESIGN. BUYERS ARE RESPONSIBLE FOR THEIR PRODUCTS AND APPLICATIONS USING NATIONAL COMPONENTS. PRIOR TO USING OR DISTRIBUTING ANY PRODUCTS THAT INCLUDE NATIONAL COMPONENTS, BUYERS SHOULD PROVIDE ADEQUATE DESIGN, TESTING AND OPERATING SAFEGUARDS.

EXCEPT AS PROVIDED IN NATIONAL'S TERMS AND CONDITIONS OF SALE FOR SUCH PRODUCTS, NATIONAL ASSUMES NO LIABILITY WHATSOEVER, AND NATIONAL DISCLAIMS ANY EXPRESS OR IMPLIED WARRANTY RELATING TO THE SALE AND/OR USE OF NATIONAL PRODUCTS INCLUDING LIABILITY OR WARRANTIES RELATING TO FITNESS FOR A PARTICULAR PURPOSE, MERCHANTABILITY, OR INFRINGEMENT OF ANY PATENT, COPYRIGHT OR OTHER INTELLECTUAL PROPERTY RIGHT.

#### LIFE SUPPORT POLICY

**NATIONAL'S PRODUCTS ARE NOT AUTHORIZED FOR USE AS CRITICAL COMPONENTS IN LIFE SUPPORT DEVICES OR SYSTEMS WITHOUT THE EXPRESS PRIOR WRITTEN APPROVAL OF THE CHIEF EXECUTIVE OFFICER AND GENERAL COUNSEL OF NATIONAL SEMICONDUCTOR CORPORATION.** As used herein:

Life support devices or systems are devices which (a) are intended for surgical implant into the body, or (b) support or sustain life and whose failure to perform when properly used in accordance with instructions for use provided in the labeling can be reasonably expected to result in a significant injury to the user. A critical component is any component in a life support device or system whose failure to perform can be reasonably expected to cause the failure of the life support device or system or to affect its safety or effectiveness.

National Semiconductor and the National Semiconductor logo are registered trademarks of National Semiconductor Corporation. All other brand or product names may be trademarks or registered trademarks of their respective holders.

Copyright© 2009 National Semiconductor Corporation

For the most current product information visit us at [www.national.com](http://www.national.com)



**National Semiconductor Americas Technical Support Center**  
 Email: [support@nsc.com](mailto:support@nsc.com)  
 Tel: 1-800-272-9959

**National Semiconductor Europe Technical Support Center**  
 Email: [europe.support@nsc.com](mailto:europe.support@nsc.com)

**National Semiconductor Asia Pacific Technical Support Center**  
 Email: [ap.support@nsc.com](mailto:ap.support@nsc.com)

**National Semiconductor Japan Technical Support Center**  
 Email: [jpn.feedback@nsc.com](mailto:jpn.feedback@nsc.com)