

# LME49600

## High Performance, High Fidelity, High Current Audio Buffer

### General Description

The LME49600 is a high performance, low distortion high fidelity 250mA audio buffer. The LME49600 is designed for a wide range of applications. It can be used inside the feedback loop of op amps.

The LME49600 offers a pin-selectable bandwidth: a low current, 110MHz bandwidth mode that consumes 7.3mA and a wide 180MHz bandwidth mode that consumes 13.2mA. In both modes the LME49600 has a nominal 2000V/ $\mu$ s slew rate. Bandwidth is easily adjusted by either leaving the BW pin unconnected or connecting a resistor between the BW pin and the  $V_{EE}$  pin.

The LME49600 is fully protected through internal current limit and thermal shutdown.

### Key Specifications

■ Low THD+N ( $V_{OUT} = 3V_{RMS}$ , $f = 1kHz$ , Figure 2)	0.00003% (typ)
■ Slew Rate	2000V/ $\mu$ s (typ)
■ High Output Current	250mA (typ)
■ Bandwidth	
BW pin floating	110MHz (typ)
BW connected to $V_{EE}$	180MHz (typ)
■ Supply Voltage Range	$\pm 2.25V \leq V_S \leq \pm 18V$

### Features

- Pin-selectable bandwidth and quiescent current
- Pure fidelity. Pure performance
- Short circuit protection
- Thermal shutdown
- TO-263 surface-mount package

### Applications

- Headphone amplifier output drive stage
- Line drivers
- Low power audio amplifiers
- High-current operational amplifier output stage
- ATE Pin Driver Buffer
- Power supply regulator

### Functional Block Diagram

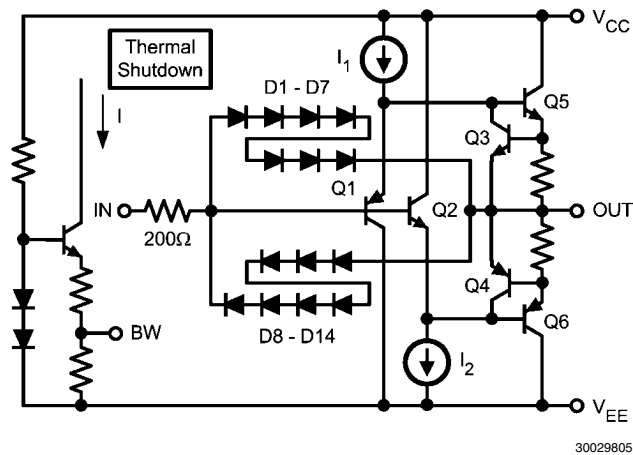
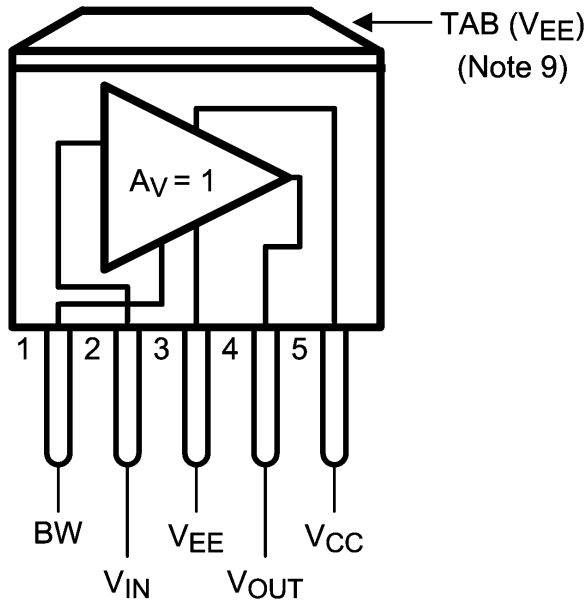

FIGURE 1. Simplified Circuit Diagram (Note:  $I_1$  and  $I_2$  are mirrored from I)

# Connection Diagrams



300298a0

**Top View**  
**Order Number LME49600TS**  
**See NS Package Number TS5B**

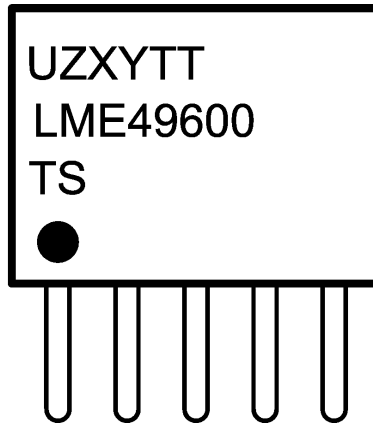

30029832

**Top View**  
**U — Wafer fabrication code**  
**Z — Assembly plant**  
**XY — 2 Digit date code**  
**TT — Lot traceability**

**Absolute Maximum Ratings** (Notes 1, 2)

If Military/Aerospace specified devices are required, please contact the National Semiconductor Sales Office/ Distributors for availability and specifications.

Supply Voltage	±20V
ESD Ratings(Note 4)	2000V
ESD Ratings (Note 5)	200V
Storage Temperature	-40°C to +150°C
Junction Temperature	150°C
Thermal Resistance	
$\theta_{JC}$	4°C/W

$\theta_{JA}$	65°C/W
$\theta_{JA}$ (Note 3)	20°C/W
Soldering Information	
TO-263 Package (10 seconds)	260°C

**Operating Ratings** (Notes 1, 2)

Temperature Range	
$T_{MIN} \leq T_A \leq T_{MAX}$	-40°C ≤ T <sub>A</sub> ≤ 85°C
Supply Voltage	±2.25V to ±18V

**System Electrical Characteristics for LME49600**

The following specifications apply for V<sub>S</sub> = ±15V, f<sub>IN</sub> = 1kHz, unless otherwise specified. Typical and limits apply for T<sub>A</sub> = 25°C.

Symbol	Parameter	Conditions	LME49600		Units (Limits)
			Typical	Limit	
			(Note 6)	(Note 7)	
I <sub>Q</sub>	Total Quiescent Current	I <sub>OUT</sub> = 0			
		BW pin: No connect BW pin: Connected to V <sub>EE</sub> pin	7.3 13.2	10.5 18	mA (max) mA (max)
THD+N	Total Harmonic Distortion + Noise (Note 8)	A <sub>V</sub> = 1, V <sub>OUT</sub> = 3V <sub>RMS</sub> , R <sub>L</sub> = 32Ω, BW = 80kHz, closed loop see Figure 2.			
		f = 1kHz f = 20kHz	0.000035 0.0005		% %
SR	Slew Rate	30 ≤ BW ≤ 180MHz V <sub>OUT</sub> = 20V <sub>P-P</sub> , R <sub>L</sub> = 100Ω	2000		V/μs
BW	Bandwidth	A <sub>V</sub> = -3dB BW pin: No Connect R <sub>L</sub> = 100Ω R <sub>L</sub> = 1kΩ	100 110		MHz MHz
		A <sub>V</sub> = -3dB BW pin: Connected to V <sub>EE</sub> pin R <sub>L</sub> = 100Ω R <sub>L</sub> = 1kΩ	160 180		MHz MHz
	Voltage Noise Density	f = 10kHz BW pin: No Connect	3.0		nV/√Hz
		f = 10kHz BW pin: Connected to V <sub>EE</sub> pin	2.6		nV/√Hz
t <sub>s</sub>	Settling Time	ΔV = 10V, R <sub>L</sub> = 100Ω 1% Accuracy BW pin: No connect BW pin: Connected to V <sub>EE</sub> pin	200 60		ns ns
		A <sub>V</sub>	Voltage Gain	V <sub>OUT</sub> = ±10V R <sub>L</sub> = 67Ω	0.93
R <sub>L</sub> = 100Ω	0.95			0.92	V/V (min)
R <sub>L</sub> = 1kΩ	0.99			0.98	V/V (min)

Symbol	Parameter	Conditions	LME49600		Units (Limits)
			Typical	Limit	
			(Note 6)	(Note 7)	
$V_{OUT}$	Voltage Output	Positive			
		$I_{OUT} = 10\text{mA}$	$V_{CC} - 1.4$	$V_{CC} - 1.6$	V (min)
		$I_{OUT} = 100\text{mA}$	$V_{CC} - 2.0$	$V_{CC} - 2.1$	V (min)
		$I_{OUT} = 150\text{mA}$	$V_{CC} - 2.3$	$V_{CC} - 2.7$	V (min)
		Negative			
		$I_{OUT} = -10\text{mA}$	$V_{EE} + 1.5$	$V_{EE} + 1.6$	V (min)
$I_{OUT} = -100\text{mA}$	$V_{EE} + 3.1$	$V_{EE} + 2.4$	V (min)		
$I_{OUT} = -150\text{mA}$	$V_{EE} + 3.5$	$V_{EE} + 3.2$	V (min)		
$I_{OUT}$	Output Current		$\pm 250$		mA
$I_{OUT-SC}$	Short Circuit Output Current	BW pin: No Connect	$\pm 490$		mA (max)
		BW pin: Connected to $V_{EE}$ pin	$\pm 490$	$\pm 550$	mA (max)
$I_B$	Input Bias Current	$V_{IN} = 0\text{V}$			
		BW pin: No Connect	$\pm 1.0$	$\pm 2.5$	$\mu\text{A}$ (max)
		BW pin: Connected to $V_{EE}$ pin	$\pm 3.0$	$\pm 5.0$	$\mu\text{A}$ (max)
$Z_{IN}$	Input Impedance	$R_L = 100\Omega$			
		BW pin: No Connect	7.5		$\text{M}\Omega$
		BW pin: Connected to $V_{EE}$ pin	5.5		$\text{M}\Omega$
$V_{OS}$	Offset Voltage		$\pm 17$	$\pm 60$	mV (max)
$V_{OS}/^\circ\text{C}$	Offset Voltage vs Temperature	$40^\circ\text{C} \leq T_A \leq +125^\circ\text{C}$	$\pm 100$		$\mu\text{V}/^\circ\text{C}$

**Note 1:** All voltages are measured with respect to ground, unless otherwise specified.

**Note 2:** *Absolute Maximum Ratings* indicate limits beyond which damage to the device may occur. *Operating Ratings* indicate conditions for which the device is functional, but do not guarantee specific performance limits. *Electrical Characteristics* state DC and AC electrical specifications under particular test conditions which guarantee specific performance limits. This assumes that the device is within the Operating Ratings. Specifications are not guaranteed for parameters where no limit is given, however, the typical value is a good indication of device performance.

**Note 3:** The maximum power dissipation must be derated at elevated temperatures and is dictated by  $T_{JMAX}$ ,  $\theta_{JA}$ , and the ambient temperature  $T_A$ . The maximum allowable power dissipation is  $P_{DMAX} = (T_{JMAX} - T_A) / \theta_{JA}$  or the number given in Absolute Maximum Ratings, whichever is lower. For the LME49600, typical application (shown in Figure 2) with  $V_{SUPPLY} = 30\text{V}$ ,  $R_L = 32\Omega$ , the total power dissipation is 1.9W.  $\theta_{JA} = 20^\circ\text{C}/\text{W}$  for the TO-263 package mounted to 16in<sup>2</sup> 1oz copper surface heat sink area.

**Note 4:** Human body model, 100pF discharged through a 1.5k $\Omega$  resistor.

**Note 5:** Machine Model, 220pF – 240pF discharged through all pins.

**Note 6:** Typical specifications are specified at 25°C and represent the parametric norm.

**Note 7:** Tested limits are guaranteed to National's AOQL (Average Outgoing Quality Level).

**Note 8:** This is the distortion of the LME49600 operating in a closed loop configuration with an LME49710. When operating in an operational amplifier's feedback loop, the amplifier's open loop gain dominates, linearizing the system and determining the overall system distortion.

**Note 9:** The TSB package is non-isolated package. The package's metal back and any heat sink to which it is mounted are connected to the same potential as the  $-V_{EE}$  pin.

# Typical Performance Characteristics

Gain vs Frequency vs Quiescent Current

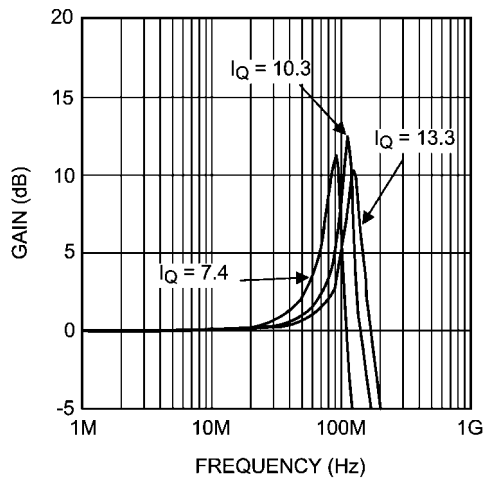

30029899

Phase vs Frequency vs Quiescent Current

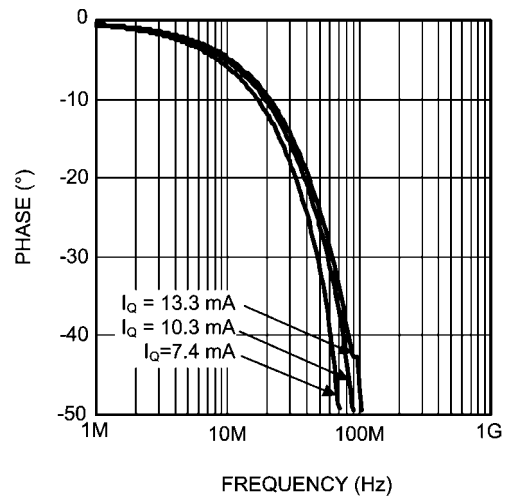

30029881

Gain vs Frequency vs Power Supply Voltage  
Wide BW Mode

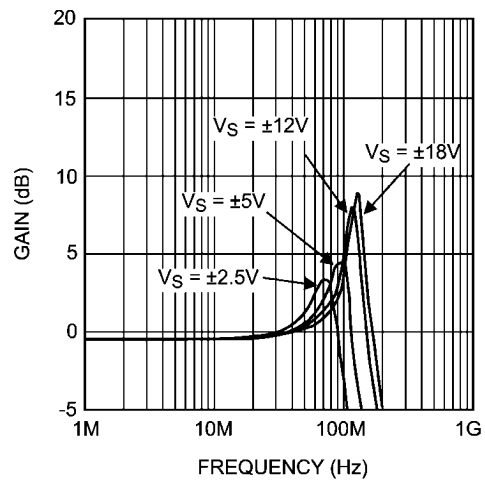

30029898

Phase vs Frequency vs Supply Voltage  
Wide BW Mode

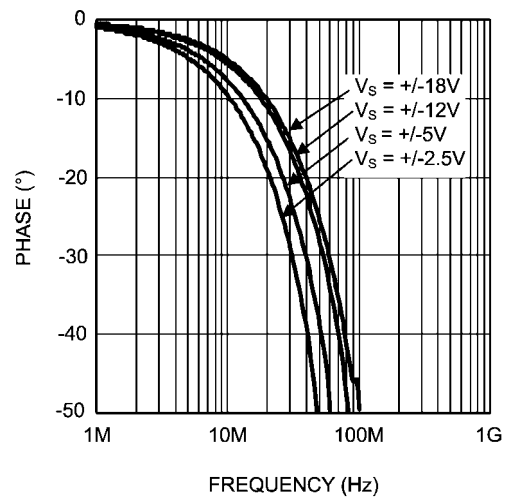

30029880

**Gain vs Frequency vs Power Supply Voltage  
Low  $I_Q$  Mode**

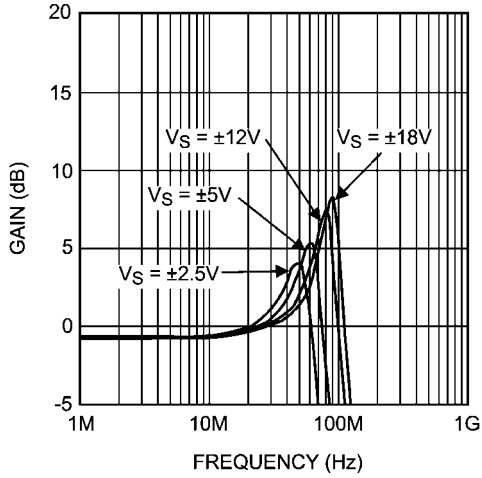

30029897

**Phase vs Frequency vs Supply Voltage  
Low  $I_Q$  Mode**

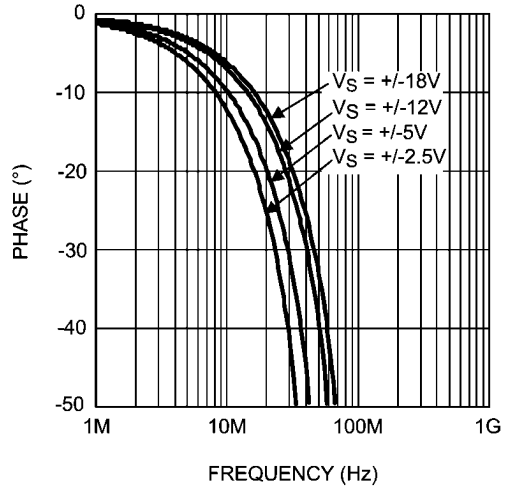

30029879

**Gain vs Frequency vs  $R_{LOAD}$   
Wide BW Mode**

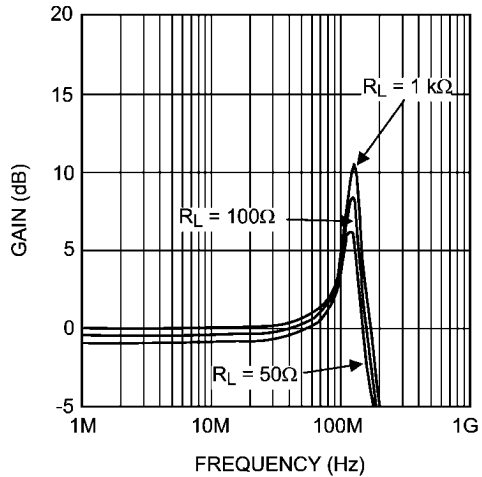

30029896

**Phase vs Frequency vs  $R_{LOAD}$   
Wide BW Mode**

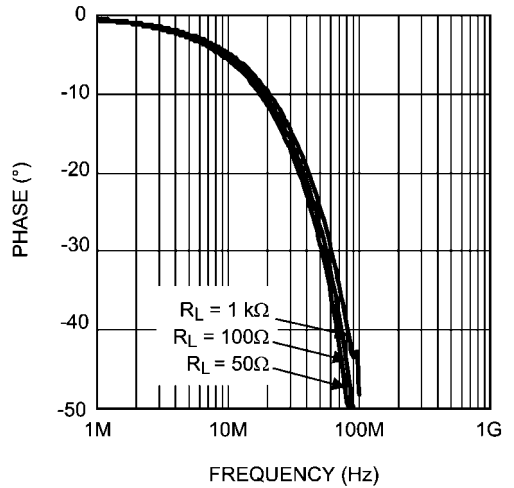

30029878

**Gain vs Frequency vs  $R_{LOAD}$   
Low  $I_Q$  Mode**

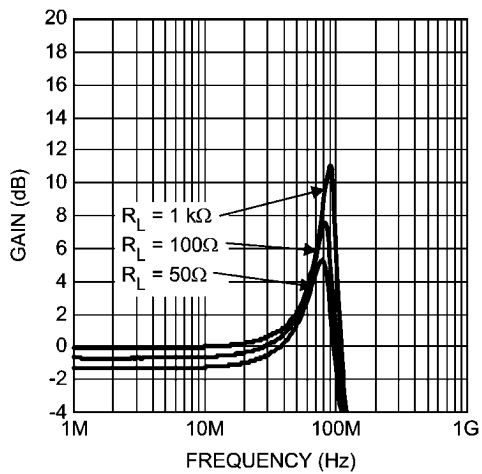

30029895

**Phase vs Frequency vs  $R_{LOAD}$   
Low  $I_Q$  Mode**

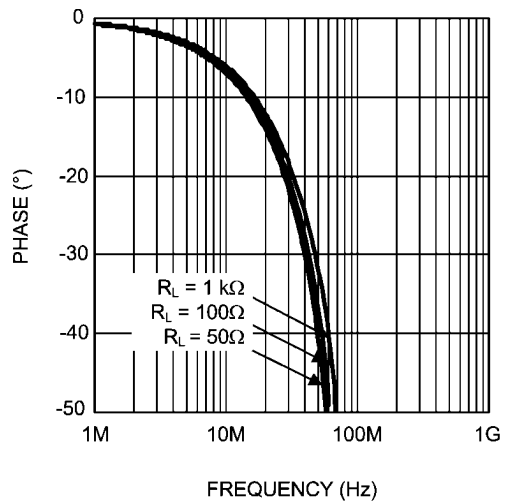

30029877

**Gain vs Frequency vs  $C_{LOAD}$   
Wide BW Mode**

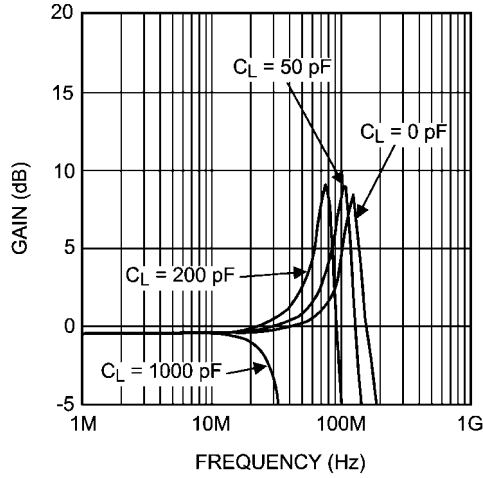

30029894

**Phase vs Frequency vs  $C_{LOAD}$   
Wide BW Mode**

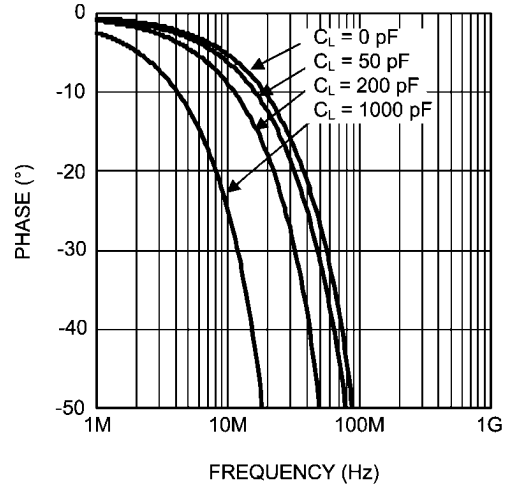

30029875

**Gain vs Frequency vs  $C_{LOAD}$   
Low  $I_Q$  Mode**

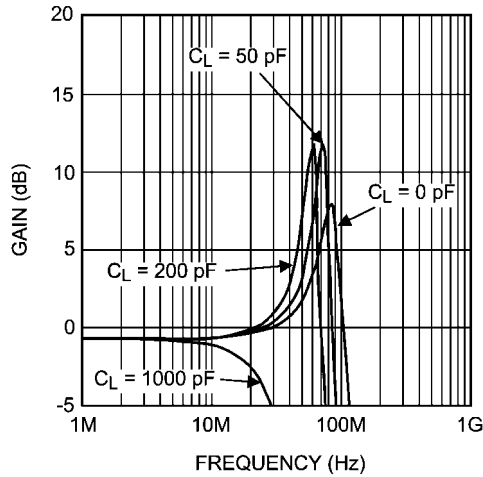

30029893

**Phase vs Frequency vs  $C_{LOAD}$   
Low  $I_Q$  Mode**

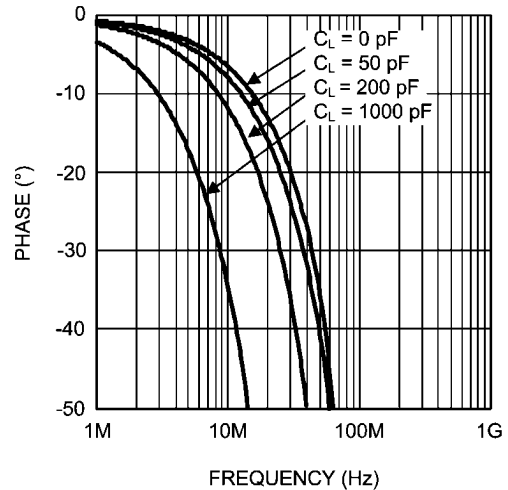

30029876

**+PSRR vs Frequency  
 $V_S = \pm 15V$ , Wide BW Mode**

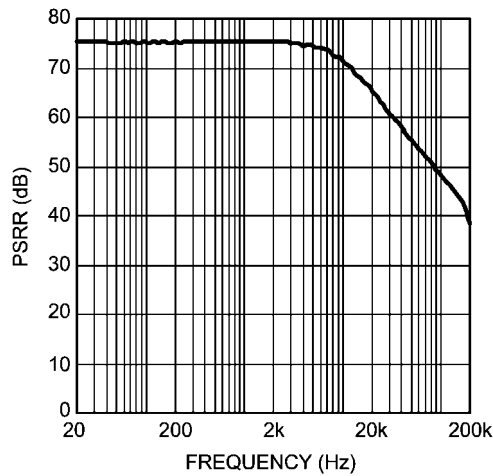

30029891

**+PSRR vs Frequency  
 $V_S = \pm 15V$ , Low  $I_Q$  Mode**

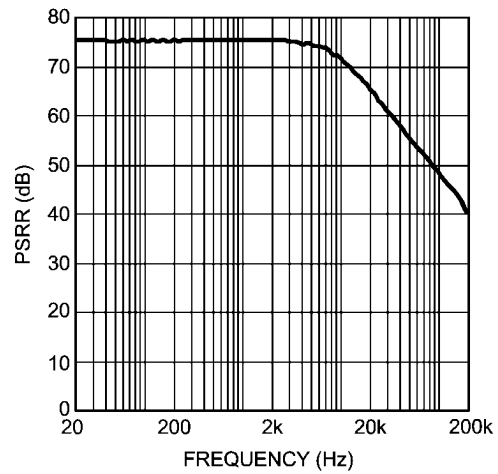

30029889

**+PSRR vs Frequency**  
 $V_S = \pm 15V$ , Wide BW Mode

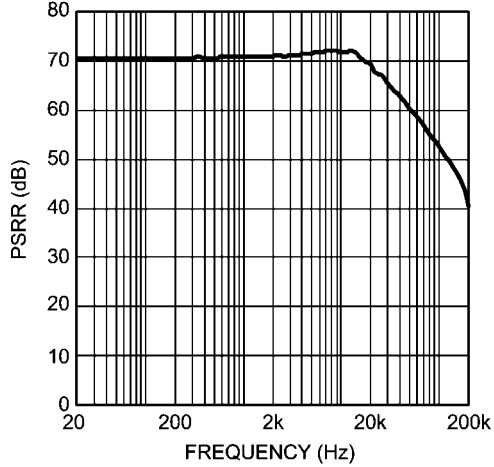

30029892

**+PSRR vs Frequency**  
 $V_S = \pm 15V$ , Low  $I_Q$  Mode

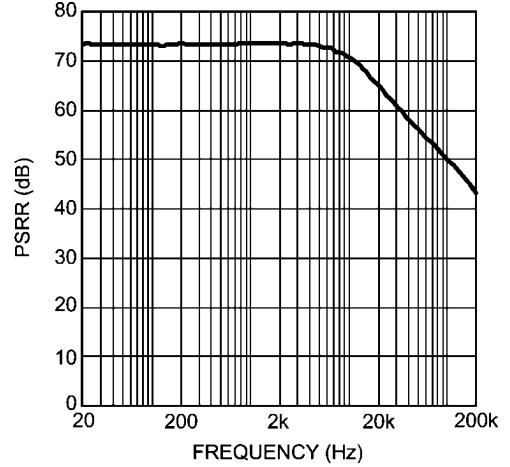

30029890

**Quiescent Current vs Bandwidth Control Resistance**

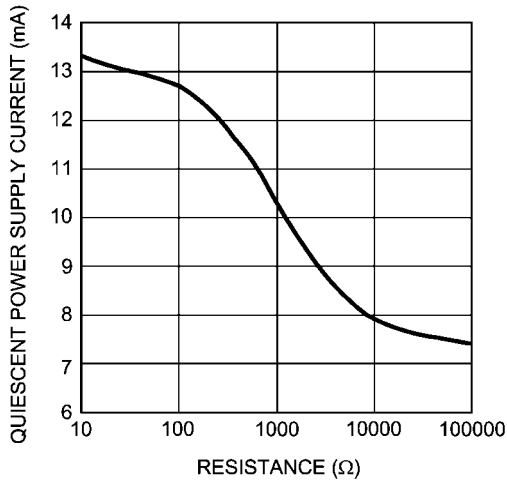

30029888

**THD+N vs Output Voltage**  
 $V_S = \pm 15V$ ,  $R_L = 32\Omega$ ,  $f = 1kHz$   
 Both channels driven

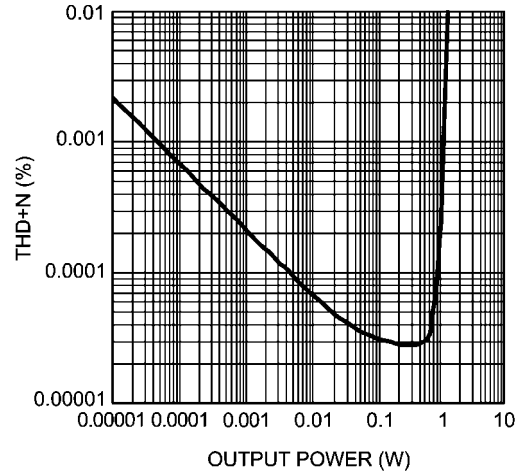

300298j4

**High BW Noise Curve**

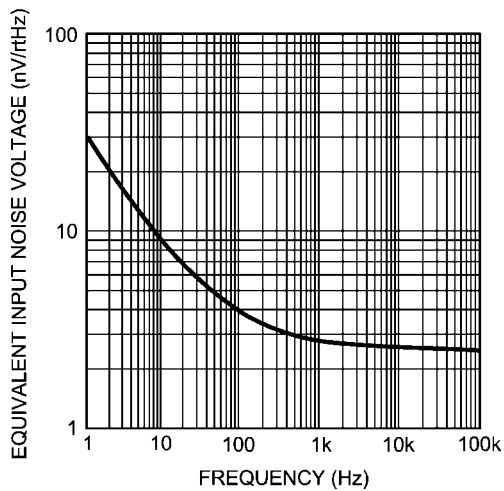

30029845

**Low BW Noise Curve**

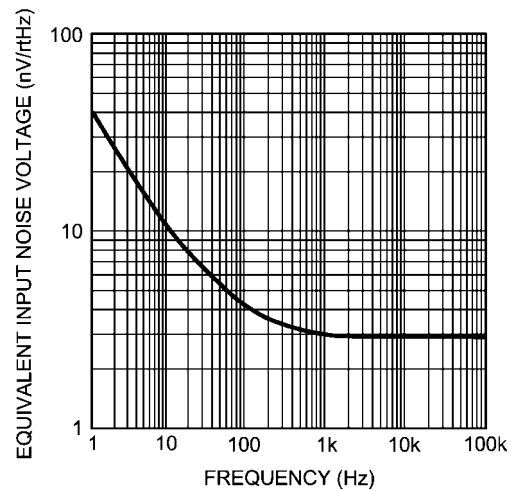

30029846



## Typical Application Diagram

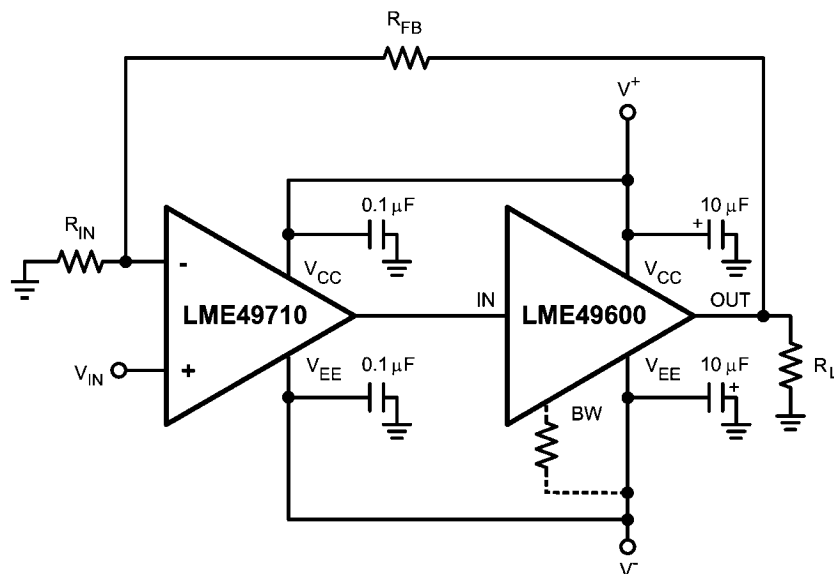

300298J5

FIGURE 2. High Performance, High Fidelity LME49600 Audio Buffer Application

### DISTORTION MEASUREMENTS

The vanishingly low residual distortion produced by LME49710/LME49600 is below the capabilities of all commercially available equipment. This makes distortion measurements just slightly more difficult than simply connecting a distortion meter to the amplifier's inputs and outputs. The solution, however, is quite simple: an additional resistor. Adding this resistor extends the resolution of the distortion measurement equipment.

The LME49710/LME49600's low residual distortion is an input referred internal error. As shown in Figure 3, adding the  $10\Omega$  resistor connected between the amplifier's inverting and non-inverting inputs changes the amplifier's noise gain. The

result is that the error signal (distortion) is amplified by a factor of 101. Although the amplifier's closed-loop gain is unaltered, the feedback available to correct distortion errors is reduced by 101, which means that measurement resolution increases by 101. To ensure minimum effects on distortion measurements, keep the value of  $R_1$  low as shown in Figure 3.

This technique is verified by duplicating the measurements with high closed loop gain and/or making the measurements at high frequencies. Doing so produces distortion components that are within the measurement equipment's capabilities. This datasheet's THD+N and IMD values were generated using the above described circuit connected to an Audio Precision System Two Cascade.

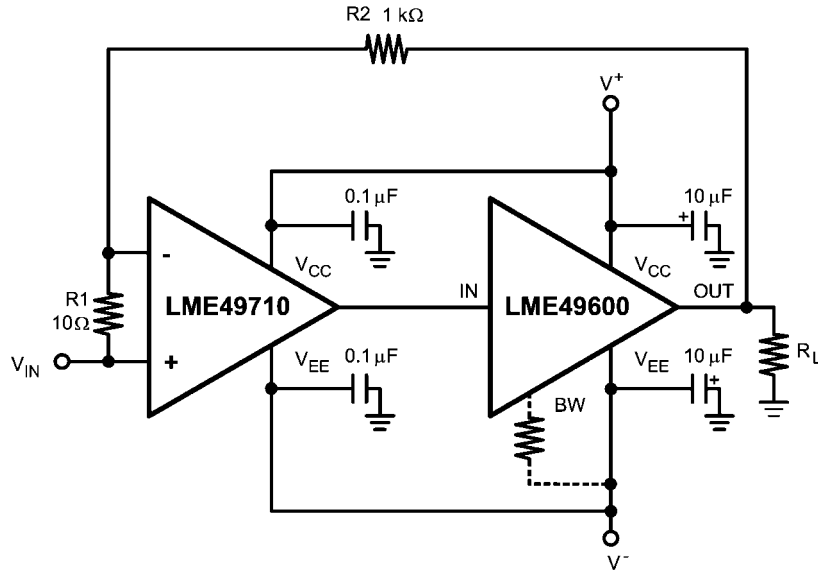

FIGURE 3. THD+N Distortion Test Circuit

## Application Information

### HIGH PERFORMANCE, HIGH FIDELITY HEADPHONE AMPLIFIER

The LME49600 is the ideal solution for high output, high performance high fidelity head phone amplifiers. When placed in the feedback loop of the LME49710, LME49720 or LME49740 High Performance, High Fidelity audio operational amplifier, the LME49600 is able to drive  $32\Omega$  headphones to a dissipation of greater than 500mW at 0.00003% THD+N while operating on  $\pm 15V$  power supply voltages. The circuit schematic for a typical headphone amplifier is shown in Figure 4.

### Operation

The following describes the circuit operation for the headphone amplifier's Left Channel. The Right Channel operates identically.

The audio input signal is applied to the input jack (HP31 or J1/J2) and dc-coupled to the volume control, VR1. The output signal from VR1's wiper is applied to the non-inverting input of U2-A, an LME49720 High Performance, High Fidelity audio operational amplifier. U2-A's AC signal gain is set by resistors R2, R4, and R6. To allow for a DC-coupled signal path and to ensure minimal output DC voltage regardless of the closed-loop gain, the other half of the U2 is configured as a DC servo. By constantly monitoring U2-A's output, the servo creates a voltage that compensates for any DC voltage that may be present at the output. A correction voltage is generated and applied to the feedback node at U2-A, pin 2. The servo ensures that the gain at DC is unity. Based on the values shown in Figure 4, the RC combination formed by R11 and C7 sets the servo's high-pass cutoff at 0.16Hz. This is over two decades below 20Hz, minimizing both amplitude and phase perturbations in the audio frequency band's lowest frequencies.

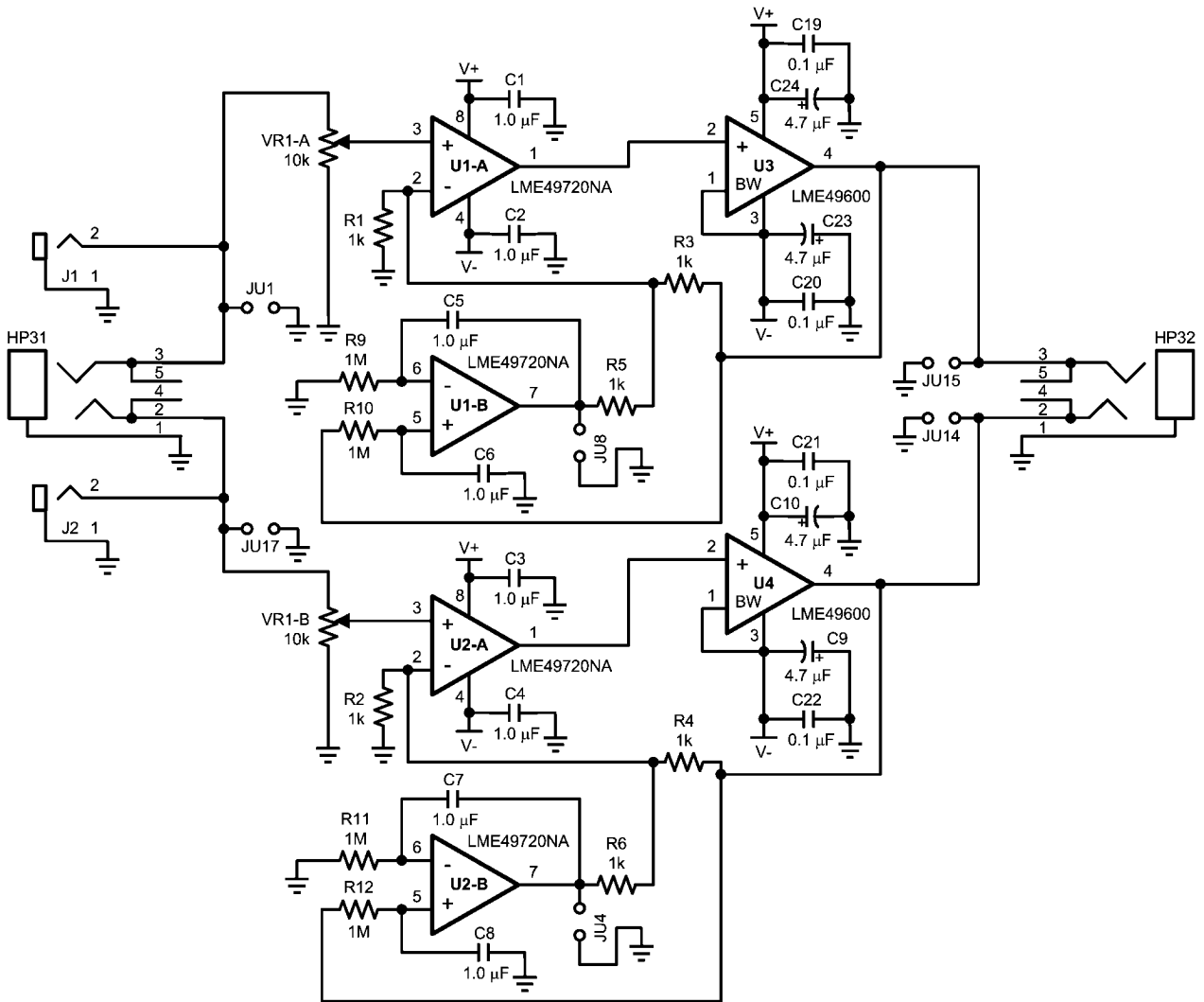

30029858

FIGURE 4. LME49600 delivers high output current for this high performance headphone amplifier

## AUDIO BUFFERS

Audio buffers or unity-gain followers, have large current gain and a voltage gain of one. Audio buffers serve many applications that require high input impedance, low output impedance and high output current. They also offer constant gain over a very wide bandwidth.

Buffers serve several useful functions, either in stand-alone applications or in tandem with operational amplifiers. In stand-alone applications, their high input impedance and low output impedance isolates a high impedance source from a low impedance load.

## SUPPLY BYPASSING

The LME49600 will place great demands on the power supply voltage source when operating in applications that require fast slewing and driving heavy loads. These conditions can create high amplitude transient currents. A power supply's limited bandwidth can reduce the supply's ability to supply the needed current demands during these high slew rate conditions. This inability to supply the current demand is further exacerbated by PCB trace or interconnecting wire inductance. The transient current flowing through the inductance can produce voltage transients.

For example, the LME49600's output voltage can slew at a typical  $\pm 2000\text{V}/\mu\text{s}$ . When driving a  $100\Omega$  load, the  $di/dt$  current demand is  $20\text{A}/\mu\text{s}$ . This current flowing through an inductance of  $50\text{nH}$  (approximately 1.5" of 22 gage wire) will produce a 1V transient. In these and similar situations, place the parallel combination of a solid  $5\mu\text{F}$  to  $10\mu\text{F}$  tantalum capacitor and a ceramic  $0.1\mu\text{F}$  capacitor as close as possible to the device supply pins.

Ceramic capacitors with values in the range of  $10\mu\text{F}$  to  $100\mu\text{F}$ , ceramic capacitor have very lower ESR (typically less than  $10\text{m}\Omega$ ) and low ESL when compared to the same valued tantalum capacitor. The ceramic capacitors, therefore, have superior AC performance for bypassing high frequency noise. In less demanding applications that have lighter loads or lower slew rates, the supply bypassing is not as critical. Capacitor values in the range of  $0.01\mu\text{F}$  to  $0.1\mu\text{F}$  are adequate.

## SIMPLIFIED LME49600 CIRCUIT DIAGRAM

The LME49600's simplified circuit diagram is shown in Figures 1 and 5. The diagram shows the LME49600's complementary emitter follower design, bias circuit and bandwidth adjustment node.

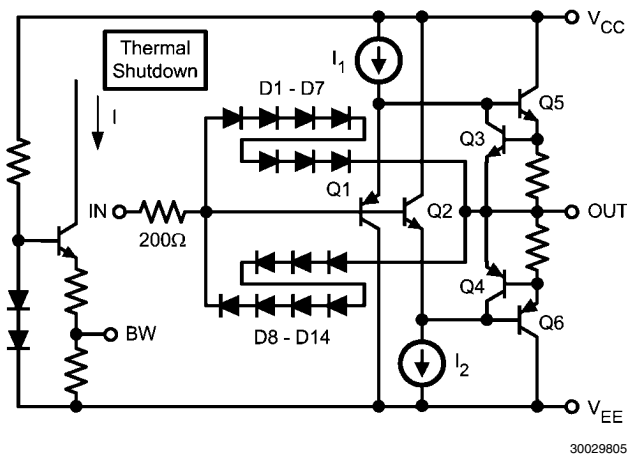

FIGURE 5. Simplified Circuit Diagram

Figure 6 shows the LME49600 connected as an open-loop buffer. The source impedance and optional input resistor,  $R_S$ , can alter the frequency response. As previously stated, the power supplies should be bypassed with capacitors connected close to the LME49600's power supply pins. Capacitor values as low as  $0.01\mu\text{F}$  to  $0.1\mu\text{F}$  will ensure stable operation in lightly loaded applications, but high output current and fast output slewing can demand large current transients from the power supplies. Place a recommended parallel combination of a solid tantalum capacitor in the  $5\mu\text{F}$  to  $10\mu\text{F}$  range and a ceramic  $0.1\mu\text{F}$  capacitor as close as possible to the device supply pins.

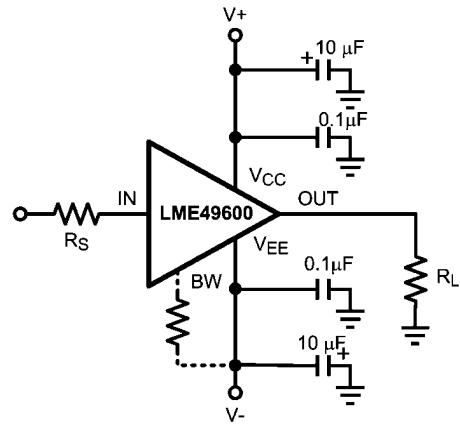

FIGURE 6. Buffer Connections

## OUTPUT CURRENT

The LME49600 can continuously source or sink  $250\text{mA}$ . Internal circuitry limits the short circuit output current to approximately  $\pm 450\text{mA}$ . For many applications that fully utilize the LME49600's current source and sink capabilities, thermal dissipation may be the factor that limits the continuous output current.

The maximum output voltage swing magnitude varies with junction temperature and output current. Using sufficient PCB copper area as a heat sink when the metal tab of the LME49600's surface mount TO-263 package is soldered directly to the circuit board reduces thermal impedance. This in turn reduces junction temperature. The PCB copper area should be in the range of  $3\text{in}^2$  ( $12.9\text{cm}^2$ ) to  $6\text{in}^2$  ( $38.7\text{cm}^2$ ).

## THERMAL PROTECTION

LME49600 power dissipated will cause the buffer's junction temperature to rise. A thermal protection circuit in the LME49600 will disable the output when the junction temperature exceeds  $150^\circ\text{C}$ . When the thermal protection is activated, the output stage is disabled, allowing the device to cool. The output circuitry is enabled when the junction temperature drops below  $150^\circ\text{C}$ .

The TO-263 package has excellent thermal characteristics. To minimize thermal impedance, its exposed die attach paddle should be soldered to a circuit board copper area for good heat dissipation. Figure 7 shows typical thermal resistance from junction to ambient as a function of the copper area. The TO-263's exposed die attach paddle is electrically connected to the  $V_{EE}$  power supply pin.

## LOAD IMPEDANCE

The LME49600 is stable under any capacitive load when driven by a source that has an impedance of 50Ω or less. When driving capacitive loads, any overshoot that is present on the output signal can be reduced by shunting the load capacitance with a resistor.

## OVERVOLTAGE PROTECTION

If the input-to-output differential voltage exceeds the LME49600's Absolute Maximum Rating of 3V, the internal diode clamps shown in Figures 1 and 5 conduct, diverting current around the compound emitter followers of Q1/Q5 (D1 – D7 for positive input), or around Q2/Q6 (D8 – D14 for negative inputs). Without this clamp, the input transistors Q1/Q2 and Q5/Q6 will zener and damage the buffer.

To ensure that the current flow through the diodes is held to a safe level, the internal 200Ω resistor in series with the input limits the current through these clamps. If the additional current that flows during this situation can damage the source that drives the LME49600's input, add an external resistor in series with the input (see Figure 6).

## BANDWIDTH CONTROL PIN

The LME49600's –3dB bandwidth is approximately 110MHz in the low quiescent-current mode (7.3mA typical). Select this mode by leaving the BW pin unconnected.

Connect the BW pin to the  $V_{EE}$  pin to extend the LME49600's bandwidth to a nominal value of 180MHz. In this mode, the quiescent current increases to approximately 13.2mA. Bandwidths between these two limits are easily selected by connecting a series resistor between the BW pin and  $V_{EE}$ .

Regardless of the connection to the LME49600's BW pin, the rated output current and slew rate remain constant. With the power supply voltage held constant, the wide-bandwidth mode's increased quiescent current causes a corresponding increase in quiescent power dissipation. For all values of the BW pin voltage, the quiescent power dissipation is equal to the total supply voltage times the quiescent current ( $I_Q \cdot (V_{CC} + |V_{EE}|)$ ).

## BOOSTING OP AMP OUTPUT CURRENT

When placed in the feedback loop, the LME49600 will increase an operational amplifier's output current. The operational amplifier's open loop gain will correct any LME49600 errors while operating inside the feedback loop.

To ensure that the operational amplifier and buffer system are closed loop stable, the phase shift must be low. For a system gain of one, the LME49600 must contribute less than 20° at the operational amplifier's unity-gain frequency. Various operating conditions may change or increase the total system phase shift. These phase shift changes may affect the operational amplifier's stability.

Unity gain stability is preserved when the LME49600 is placed in the feedback loop of most general-purpose or precision op amps. When the LME49600 is driving high value capacitive loads, the BW pin should be connected to the  $V_{EE}$  pin for wide bandwidth and stable operation. The wide bandwidth mode is also suggested for high speed or fast-settling operational amplifiers. This preserves their stability and the ability to faithfully amplify high frequency, fast-changing signals. Stability is ensured when pulsed signals exhibit no oscillations and ringing is minimized while driving the intended load and operating in the worst-case conditions that perturb the LME49600's phase response.

## HIGH FREQUENCY APPLICATIONS

The LME49600's wide bandwidth and very high slew rate make it ideal for a variety of high-frequency open-loop applications such as an ADC input driver, 75Ω stepped volume attenuator driver, and other low impedance loads. Circuit board layout and bypassing techniques affect high frequency, fast signal dynamic performance when the LME49600 operates open-loop.

A ground plane type circuit board layout is best for very high frequency performance results. Bypass the power supply pins ( $V_{CC}$  and  $V_{EE}$ ) with 0.1μF ceramic chip capacitors in parallel with solid tantalum 10μF capacitors placed as close as possible to the respective pins.

Source resistance can affect high-frequency peaking and step response overshoot and ringing. Depending on the signal source, source impedance and layout, best nominal response may require an additional resistance of 25Ω to 200Ω in series with the input. Response with some loads (especially capacitive) can be improved with an output series resistor in the range of 10Ω to 150Ω.

## THERMAL MANAGEMENT

### Heatsinking

For some applications, the LME49600 may require a heat sink. The use of a heat sink is dependent on the maximum LME49600 power dissipation and a given application's maximum ambient temperature. In the TO-263 package, heat sinking the LME49600 is easily accomplished by soldering the package's tab to a copper plane on the PCB. (Note: The tab on the LME49600's TO-263 package is electrically connected to  $V_{EE}$ .)

Through the mechanisms of convection, heat conducts from the LME49600 in all directions. A large percentage moves to the surrounding air, some is absorbed by the circuit board material and some is absorbed by the copper traces connected to the package's pins. From the PCB material and the copper, it then moves to the air. Natural convection depends on the amount of surface area that contacts the air.

If a heat conductive copper plane has perfect thermal conduction (heat spreading) through the plane's total area, the temperature rise is inversely proportional to the total exposed area. PCB copper planes are, in that sense, an aid to convection. These planes, however, are not thick enough to ensure perfect heat conduction. Therefore, eventually a point of diminishing returns is reached where increasing copper area offers no additional heat conduction to the surrounding air. This is apparent in Figure 7 as the thermal resistance reaches an asymptote above a copper area of 8in<sup>2</sup>). As can be seen, increasing the copper area produces decreasing improvements in thermal resistance. This occurs, roughly, at 4in<sup>2</sup> of 1 oz copper board. Some improvement continues until about 16in<sup>2</sup>. Boards using 2 oz copper boards will have decrease thermal resistance providing a better heat sink compared to 1 oz. copper. Beyond 1oz or 2oz copper plane areas, external heat sinks are required. Ultimately, the 1oz copper area attains a nominal value of 20°C/W junction to ambient thermal resistance ( $\theta_{JA}$ ) under zero air flow.

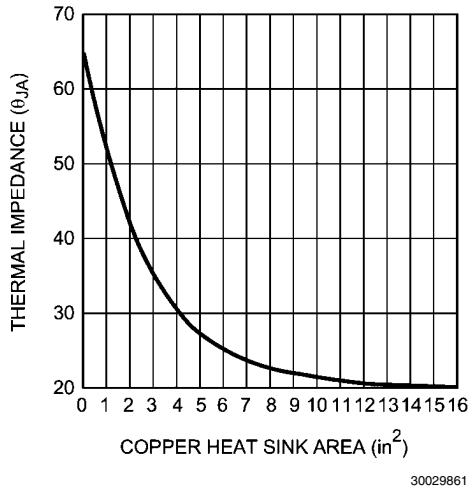

**FIGURE 7. Thermal Resistance for 5 lead TO-263 Package Mounted on 1oz. Copper**

A copper plane may be placed directly beneath the tab. Additionally, a matching plane can be placed on the opposite side. If a plane is placed on the side opposite of the LME49600, connect it to the plane to which the buffer's metal tab is soldered with a matrix of thermal vias per JEDEC Standard JESD51-5.

#### Determining Copper Area

Find the required copper heat sink area using the following guidelines:

1. Determine the value of the circuit's power dissipation,  $P_D$ .
2. Specify a maximum operating ambient temperature,  $T_{A(MAX)}$ . (Note that the die temperature,  $T_J$ , will be higher than  $T_{A(MAX)}$ . Therefore,  $T_A$  must be specified such that  $T_J$  does not exceed the absolute maximum die temperature of 150°C.
3. Specify a maximum allowable junction temperature,  $T_{J(MAX)}$ . This is the LME49600's die temperature when the buffer is drawing maximum current (quiescent and load). It is prudent to design for a maximum continuous junction temperature of 100°C to 130°C. Ensure, however, that the junction temperature never exceeds the 150°C absolute maximum rating for the part.
4. Calculate the value of junction to ambient thermal resistance,  $\theta_{JA}$ .
5.  $\theta_{JA}$  as a function of copper area in square inches is shown in Figure 7. Choose a copper area that will guarantee the specified  $T_{J(MAX)}$  for the calculated  $\theta_{JA}$ . The maximum value of junction to ambient thermal resistance,  $\theta_{JA}$ , is defined as:

$$\theta_{JA} = (T_{J(MAX)} - T_{A(MAX)}) / P_{D(MAX)} \quad (^\circ\text{C}/\text{W}) \quad (1)$$

where:

$T_{J(MAX)}$  = the maximum recommended junction temperature

$T_{A(MAX)}$  = the maximum ambient temperature in the LME49600's environment

$P_{D(MAX)}$  = the maximum recommended power dissipation

Note: The allowable thermal resistance is determined by the maximum allowable temperature increase:

$$T_{RISE} = T_{J(MAX)} - T_{A(MAX)}$$

Thus, if ambient temperature extremes force  $T_{RISE}$  to exceed the design maximum, the part must be de-rated by either decreasing  $P_D$  to a safe level, reducing  $\theta_{JA}$  further or, if available, using a larger copper area.

#### Procedure

1. First determine the maximum power dissipated by the LME49600,  $P_{D(MAX)}$ . For the simple case of the buffer driving a resistive load, and assuming equal supplies,  $P_{D(MAX)}$  is given by:

$$P_{D(MAX)(AC)} = (I_S \times V_S) + (V_S)^2 / (2\pi^2 R_L) \quad (\text{Watts}) \quad (2)$$

$$P_{D(MAX)(DC)} = (I_S \times V_S) + (V_S)^2 / R_L \quad (\text{Watts}) \quad (3)$$

where:

$$V_S = |V_{EE}| + V_{CC} \quad (\text{V})$$

$$I_S = \text{quiescent supply current (A)}$$

Equation (2) is for sinusoidal output voltages and (3) is for DC output voltages

2. Determine the maximum allowable die temperature rise,

$$T_{RISE(MAX)} = T_{J(MAX)} - T_{A(MAX)} \quad (^\circ\text{C})$$

3. Using the calculated value of  $T_{RISE(MAX)}$  and  $P_{D(MAX)}$ , find the required value of junction to ambient thermal resistance combining equation 1 and equation 4 to derive equation 5:

$$\theta_{JA} = T_{RISE(MAX)} / P_{D(MAX)} \quad (4)$$

4. Finally, choose the minimum value of copper area from Figure 7 based on the value for  $\theta_{JA}$ .

#### Example

Assume the following conditions:  $V_S = |V_{EE}| + V_{CC} = 30\text{V}$ ,  $R_L = 32\Omega$ ,  $I_S = 15\text{mA}$ , sinusoidal output voltage,  $T_{J(MAX)} = 125^\circ\text{C}$ ,  $T_{A(MAX)} = 85^\circ\text{C}$ .

Applying Equation (2):

$$\begin{aligned} P_{D(MAX)} &= (I_S \times V_S) + (V_S)^2 / 2\pi^2 R_L \\ &= (15\text{mA})(30\text{V}) + 900\text{V}^2 / 142\Omega \\ &= 1.86\text{W} \end{aligned}$$

Applying Equation (4):

$$\begin{aligned} T_{RISE(MAX)} &= 125^\circ\text{C} - 85^\circ\text{C} \\ &= 40^\circ\text{C} \end{aligned}$$

Applying Equation (5):

$$\begin{aligned} \theta_{JA} &= 40^\circ\text{C} / 1.86\text{W} \\ &= 21.5^\circ\text{C}/\text{W} \end{aligned}$$

Examining the Copper Area vs.  $\theta_{JA}$  plot indicates that a thermal resistance of 50°C/W is possible with a 12in<sup>2</sup> plane of one layer of 1oz copper. Other solutions include using two layers of 1oz copper or the use of 2oz copper. Higher dissipation may require forced air flow. As a safety margin, an extra 15% heat sinking capability is recommended.

When amplifying AC signals, wave shapes and the nature of the load (reactive, non-reactive) also influence dissipation. Peak dissipation can be several times the average with reactive loads. It is particularly important to determine dissipation when driving large load capacitance.

The LME49600's dissipation in DC circuit applications is easily computed using Equation (3). After the value of dissipation is determined, the heat sink copper area calculation is the same as for AC signals.

### SLEW RATE

A buffer's voltage slew rate is its output signal's rate of change with respect to an input signal's step changes. For resistive

loads, slew rate is limited by internal circuit capacitance and operating current (in general, the higher the operating current for a given internal capacitance, the faster the slew rate).

However, when driving capacitive loads, the slew rate may be limited by the available peak output current according to the following expression.

$$dv/dt = I_{PK} / C_L \quad (5)$$

Output voltages with high slew rates will require large output load currents. For example if the part is required to slew at 1000V/ $\mu$ s with a load capacitance of 1nF, the current demanded from the LME49600 is 1A. Therefore, fast slew rate is incompatible with a capacitive load of this value. Also, if  $C_L$  is in parallel with the load, the peak current available to the load decreases as  $C_L$  increases.

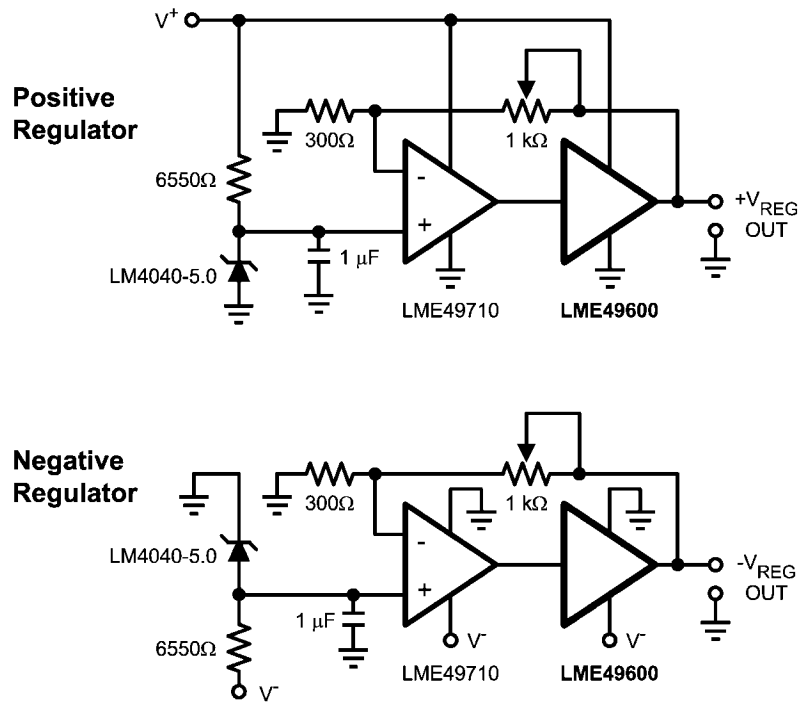

30029844

FIGURE 8. High Speed Positive and Negative Regulator



## Revision History

Rev	Date	Description
1.0	01/15/08	Initial release.
1.01	01/16/08	Edited specification table.
1.02	02/07/08	Edited applications information.
1.03	03/28/08	Text edits.

**Physical Dimensions** inches (millimeters) unless otherwise noted

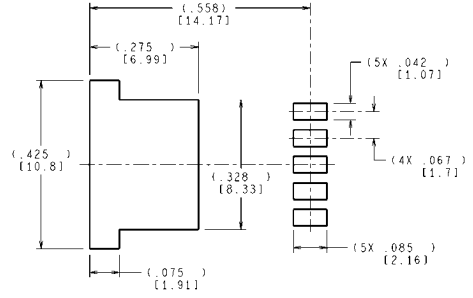
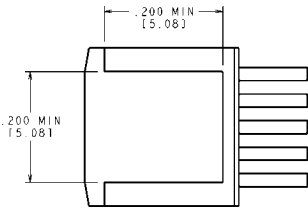
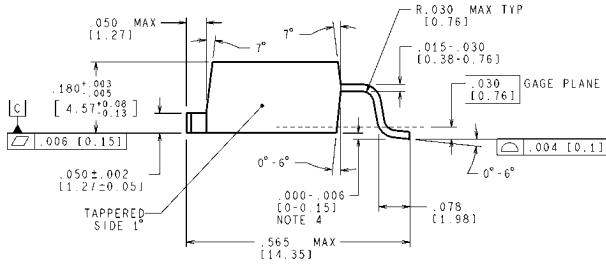
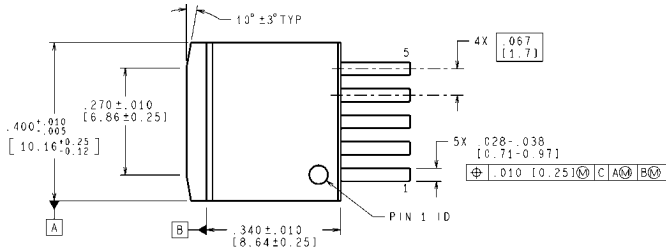

LAND PATTERN RECOMMENDATION

CONTROLLING DIMENSION IS INCH  
 VALUES IN [ ] ARE MILLIMETERS  
 DIMENSIONS IN ( ) FOR REFERENCE ONLY

**Order Number LME49600TS**  
**See NS Package TS5B**

TS5B (Rev D)

# Notes

LME49600

## Notes

For more National Semiconductor product information and proven design tools, visit the following Web sites at:

Products		Design Support	
Amplifiers	<a href="http://www.national.com/amplifiers">www.national.com/amplifiers</a>	WEBENCH	<a href="http://www.national.com/webench">www.national.com/webench</a>
Audio	<a href="http://www.national.com/audio">www.national.com/audio</a>	Analog University	<a href="http://www.national.com/AU">www.national.com/AU</a>
Clock Conditioners	<a href="http://www.national.com/timing">www.national.com/timing</a>	App Notes	<a href="http://www.national.com/appnotes">www.national.com/appnotes</a>
Data Converters	<a href="http://www.national.com/adc">www.national.com/adc</a>	Distributors	<a href="http://www.national.com/contacts">www.national.com/contacts</a>
Displays	<a href="http://www.national.com/displays">www.national.com/displays</a>	Green Compliance	<a href="http://www.national.com/quality/green">www.national.com/quality/green</a>
Ethernet	<a href="http://www.national.com/ethernet">www.national.com/ethernet</a>	Packaging	<a href="http://www.national.com/packaging">www.national.com/packaging</a>
Interface	<a href="http://www.national.com/interface">www.national.com/interface</a>	Quality and Reliability	<a href="http://www.national.com/quality">www.national.com/quality</a>
LVDS	<a href="http://www.national.com/lvds">www.national.com/lvds</a>	Reference Designs	<a href="http://www.national.com/refdesigns">www.national.com/refdesigns</a>
Power Management	<a href="http://www.national.com/power">www.national.com/power</a>	Feedback	<a href="http://www.national.com/feedback">www.national.com/feedback</a>
Switching Regulators	<a href="http://www.national.com/switchers">www.national.com/switchers</a>		
LDOs	<a href="http://www.national.com/ldo">www.national.com/ldo</a>		
LED Lighting	<a href="http://www.national.com/led">www.national.com/led</a>		
PowerWise	<a href="http://www.national.com/powerwise">www.national.com/powerwise</a>		
Serial Digital Interface (SDI)	<a href="http://www.national.com/sdi">www.national.com/sdi</a>		
Temperature Sensors	<a href="http://www.national.com/tempsensors">www.national.com/tempsensors</a>		
Wireless (PLL/VCO)	<a href="http://www.national.com/wireless">www.national.com/wireless</a>		

THE CONTENTS OF THIS DOCUMENT ARE PROVIDED IN CONNECTION WITH NATIONAL SEMICONDUCTOR CORPORATION ("NATIONAL") PRODUCTS. NATIONAL MAKES NO REPRESENTATIONS OR WARRANTIES WITH RESPECT TO THE ACCURACY OR COMPLETENESS OF THE CONTENTS OF THIS PUBLICATION AND RESERVES THE RIGHT TO MAKE CHANGES TO SPECIFICATIONS AND PRODUCT DESCRIPTIONS AT ANY TIME WITHOUT NOTICE. NO LICENSE, WHETHER EXPRESS, IMPLIED, ARISING BY ESTOPPEL OR OTHERWISE, TO ANY INTELLECTUAL PROPERTY RIGHTS IS GRANTED BY THIS DOCUMENT.

TESTING AND OTHER QUALITY CONTROLS ARE USED TO THE EXTENT NATIONAL DEEMS NECESSARY TO SUPPORT NATIONAL'S PRODUCT WARRANTY. EXCEPT WHERE MANDATED BY GOVERNMENT REQUIREMENTS, TESTING OF ALL PARAMETERS OF EACH PRODUCT IS NOT NECESSARILY PERFORMED. NATIONAL ASSUMES NO LIABILITY FOR APPLICATIONS ASSISTANCE OR BUYER PRODUCT DESIGN. BUYERS ARE RESPONSIBLE FOR THEIR PRODUCTS AND APPLICATIONS USING NATIONAL COMPONENTS. PRIOR TO USING OR DISTRIBUTING ANY PRODUCTS THAT INCLUDE NATIONAL COMPONENTS, BUYERS SHOULD PROVIDE ADEQUATE DESIGN, TESTING AND OPERATING SAFEGUARDS.

EXCEPT AS PROVIDED IN NATIONAL'S TERMS AND CONDITIONS OF SALE FOR SUCH PRODUCTS, NATIONAL ASSUMES NO LIABILITY WHATSOEVER, AND NATIONAL DISCLAIMS ANY EXPRESS OR IMPLIED WARRANTY RELATING TO THE SALE AND/OR USE OF NATIONAL PRODUCTS INCLUDING LIABILITY OR WARRANTIES RELATING TO FITNESS FOR A PARTICULAR PURPOSE, MERCHANTABILITY, OR INFRINGEMENT OF ANY PATENT, COPYRIGHT OR OTHER INTELLECTUAL PROPERTY RIGHT.

### LIFE SUPPORT POLICY

**NATIONAL'S PRODUCTS ARE NOT AUTHORIZED FOR USE AS CRITICAL COMPONENTS IN LIFE SUPPORT DEVICES OR SYSTEMS WITHOUT THE EXPRESS PRIOR WRITTEN APPROVAL OF THE CHIEF EXECUTIVE OFFICER AND GENERAL COUNSEL OF NATIONAL SEMICONDUCTOR CORPORATION.** As used herein:

Life support devices or systems are devices which (a) are intended for surgical implant into the body, or (b) support or sustain life and whose failure to perform when properly used in accordance with instructions for use provided in the labeling can be reasonably expected to result in a significant injury to the user. A critical component is any component in a life support device or system whose failure to perform can be reasonably expected to cause the failure of the life support device or system or to affect its safety or effectiveness.

National Semiconductor and the National Semiconductor logo are registered trademarks of National Semiconductor Corporation. All other brand or product names may be trademarks or registered trademarks of their respective holders.

Copyright© 2008 National Semiconductor Corporation

For the most current product information visit us at [www.national.com](http://www.national.com)



**National Semiconductor  
Americas Technical  
Support Center**  
Email:  
[new.feedback@nsc.com](mailto:new.feedback@nsc.com)  
Tel: 1-800-272-9959

**National Semiconductor Europe  
Technical Support Center**  
Email: [europe.support@nsc.com](mailto:europe.support@nsc.com)  
German Tel: +49 (0) 180 5010 771  
English Tel: +44 (0) 870 850 4288

**National Semiconductor Asia  
Pacific Technical Support Center**  
Email: [ap.support@nsc.com](mailto:ap.support@nsc.com)

**National Semiconductor Japan  
Technical Support Center**  
Email: [jpn.feedback@nsc.com](mailto:jpn.feedback@nsc.com)