

# LMC7215/LMC7225

## Micro-Power, Rail-to-Rail CMOS Comparators with Push-Pull/Open-Drain Outputs and TinyPak™ Package

### General Description

The LMC7215/LMC7225 are ultra low power comparators with a maximum of 1  $\mu\text{A}$  power supply current. They are designed to operate over a wide range of supply voltages, from 2V to 8V.

The LMC7215/LMC7225 have a greater than rail-to-rail common mode voltage range. This is a real advantage in single supply applications.

The LMC7215 features a push-pull output stage. This feature allows operation with absolute minimum amount of power consumption when driving any load.

The LMC7225 features an open drain output. By connecting an external resistor, the output of the comparator can be used as a level shifter to any desired voltage to as high as 15V.

The LMC7215/LMC7225 are designed for systems where low power consumption is the critical parameter.

Guaranteed operation over the full supply voltage range of 2.7V to 5V and rail-to-rail performance makes this comparator ideal for battery-powered applications.

### Features

(Typical unless otherwise noted)

- Ultra low power consumption 0.7  $\mu\text{A}$
- Wide range of supply voltages 2V to 8V
- Input common-mode range beyond  $V^+$  and  $V^-$
- Open collector and push-pull output
- High output current drive: (@  $V_S = 5\text{V}$ ) 45 mA
- Propagation delay (@  $V_S = 5\text{V}$ , 10 mV overdrive) 25  $\mu\text{s}$
- Tiny 5-Pin SOT23 package
- Latch-up resistance >300 mA

### Applications

- Laptop computers
- Mobile phones
- Metering systems
- Hand-held electronics
- RC timers
- Alarm and monitoring circuits
- Window comparators, multivibrators

### Connection Diagrams

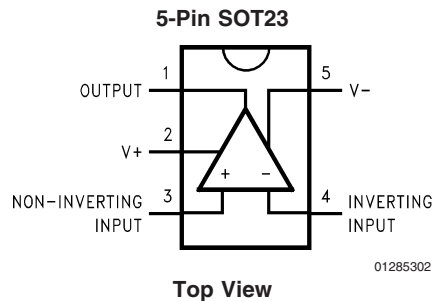
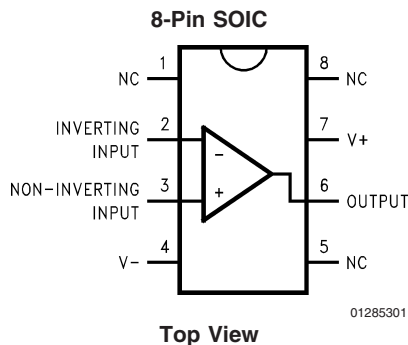

**Absolute Maximum Ratings** (Note 1)

If Military/Aerospace specified devices are required, please contact the National Semiconductor Sales Office/Distributors for availability and specifications.

ESD Tolerance (Note 2)	2 kV
Differential Input Voltage	$V^+ +0.3V, V^- -0.3V$
Voltage at Input/Output Pin	$V^+ +0.3V, V^- -0.3V$
Supply Voltage ( $V^+ - V^-$ )	10V
Current at Input Pin	$\pm 5$ mA
Current at Output Pin (Note 3)	$\pm 30$ mA
Current at Power Supply Pin	40 mA

Lead Temperature (soldering, 10 sec)	260°C
Storage Temperature Range	-65°C to +150°C
Junction Temperature (Note 4)	150°C

**Operating Ratings**(Note 1)

Supply Voltage	$2V \leq V_{CC} \leq 8V$
Temperature Range(Note 4) LMC7215IM, LMC7225IM	-40°C to +85°C
Package Thermal Resistance ( $\theta_{JA}$ )	
8-Pin SOIC	165°C/W
5-Pin SOT23	325°C/W

**2.7V to 5V Electrical Characteristics**

Unless otherwise specified, all limits guaranteed for  $T_J = 25^\circ\text{C}$ ,  $V^+ = 2.7V$  to  $5V$ ,  $V^- = 0V$ ,  $V_{CM} = V_O = V^+/2$ . **Boldface** limits apply at the temperature extremes.

Symbol	Parameter	Conditions	Typ (Note 5)	LMC7215 Limit (Note 6)	LMC7225 Limit (Note 6)	Units
$V_{OS}$	Input Offset Voltage		1	6 <b>8</b>	6 <b>8</b>	mV max
$TCV_{OS}$	Input Offset Voltage Average Drift		2			$\mu\text{V}/^\circ\text{C}$
$I_B$	Input Current		5			fA
$I_{OS}$	Input Offset Current		1			fA
CMRR	Common Mode Rejection Ratio	(Note 7)	80	60	60	dB min
PSRR	Power Supply Rejection Ratio	$V^+ = 2.2V$ to $8V$	90	60	60	dB min
$A_V$	Voltage Gain		140			dB
CMVR	Input Common-Mode Voltage Range	$V^+ = 2.7V$ CMRR > 50 dB	3.0	2.9 <b>2.7</b>	2.9 <b>2.7</b>	V min
		$V^+ = 2.7V$ CMRR > 50 dB	-0.2	0.0 <b>0.2</b>	0.0 <b>0.2</b>	V max
		$V^+ = 5.0V$ CMRR > 50 dB	5.3	5.2 <b>5.0</b>	5.2 <b>5.0</b>	V min
		$V^+ = 5.0V$ CMRR > 50 dB	-0.3	-0.2 <b>0.0</b>	-0.2 <b>0.0</b>	V max
$V_{OH}$	Output Voltage High	$V^+ = 2.2V$ $I_{OH} = 1.5$ mA	2.05	1.8 <b>1.7</b>	NA	V min
		$V^+ = 2.7V$ $I_{OH} = 2.0$ mA	2.05	2.3 <b>2.2</b>	NA	V min
		$V^+ = 5.0V$ $I_{OH} = 4.0$ mA	4.8	4.6 <b>4.5</b>	NA	V min
$V_{OL}$	Output Voltage Low	$V^+ = 2.2V$ $I_{OH} = 1.5$ mA	0.17	0.4 <b>0.5</b>	0.4 <b>0.5</b>	V max
		$V^+ = 2.7V$ $I_{OH} = 2.0$ mA	0.17	0.4 <b>0.5</b>	0.4 <b>0.5</b>	V max
		$V^+ = 5.0V$ $I_{OH} = 4.0$ mA	0.2	0.4 <b>0.5</b>	0.4 <b>0.5</b>	V max
$I_{SC+}$	Output Short Circuit	$V^+ = 2.7V$ , Sourcing	15		NA	mA

## 2.7V to 5V Electrical Characteristics (Continued)

Unless otherwise specified, all limits guaranteed for  $T_J = 25^\circ\text{C}$ ,  $V^+ = 2.7\text{V}$  to  $5\text{V}$ ,  $V^- = 0\text{V}$ ,  $V_{CM} = V_O = V^+/2$ . **Boldface** limits apply at the temperature extremes.

Symbol	Parameter	Conditions	Typ (Note 5)	LMC7215 Limit (Note 6)	LMC7225 Limit (Note 6)	Units
	Current (Note 10)	$V^+ = 5.0\text{V}$ , Sourcing	50		NA	mA
$I_{SC-}$	Output Short Circuit	$V^+ = 2.7\text{V}$ , Sinking	12			mA
	Current (Note 10)	$V^+ = 5.0\text{V}$ , Sinking	30			mA
$I_{Leakage}$	Output Leakage Current	$V^+ = 2.2\text{V}$ $V_{IN^+} = 0.1\text{V}$ , $V_{IN^-} = 0\text{V}$ , $V_{OUT} = 15\text{V}$	0.01	NA	500	nA max
$I_S$	Supply Current	$V^+ = 5.0\text{V}$	0.7	<b>1</b>	<b>1</b>	$\mu\text{A}$
		$V_{IN^+} = 5\text{V}$ , $V_{IN^-} = 0\text{V}$		<b>1.2</b>	<b>1.2</b>	max

## AC Electrical Characteristics

Unless otherwise specified,  $T_J = 25^\circ\text{C}$ ,  $V^+ = 5\text{V}$ ,  $V^- = 0\text{V}$ ,  $V_{CM} = V^+/2$

Symbol	Parameter	Conditions	LMC7215 Typ (Note 5)	LMC7225 Typ (Notes 5, 8)	Units	
$t_{rise}$	Rise Time	Overdrive = 10 mV (Note 8)	1	12.2	$\mu\text{s}$	
$t_{fall}$	Fall Time	Overdrive = 10 mV (Note 8)	0.4	0.35	$\mu\text{s}$	
$t_{PHL}$	Propagation Delay (High to Low)	(Notes 8, 9)	Overdrive = 10 mV	24	24	$\mu\text{s}$
			Overdrive = 100 mV	12	12	
		$V^+ = 2.7\text{V}$ (Notes 8, 9)	Overdrive = 10 mV	17	17	$\mu\text{s}$
			Overdrive = 100 mV	11	11	
$t_{PLH}$	Propagation Delay (Low to High)	(Notes 8, 9)	Overdrive = 10 mV	24	29	$\mu\text{s}$
			Overdrive = 100 mV	12	17	
		$V^+ = 2.7\text{V}$ (Notes 8, 9)	Overdrive = 10 mV	17	22	$\mu\text{s}$
			Overdrive = 100 mV	11	16	

**Note 1:** Absolute Maximum Ratings indicate limits beyond which damage to the device may occur. Operating Ratings indicate conditions for which the device is intended to be functional, but specific performance is not guaranteed. For guaranteed specifications and the test conditions, see the Electrical Characteristics.

**Note 2:** Human Body Model, applicable std. MIL-STD-883, Method 3015.7. Machine Model, applicable std. JESD22-A115-A (ESD MM std. of JEDEC). Field-Induced Charge-Device Model, applicable std. JESD22-C101-C (ESD FICDM std. of JEDEC).

**Note 3:** Applies to both single-supply and split-supply operation. Continuous short circuit operation at elevated ambient temperature can result in exceeding the maximum allowed junction temperature of  $150^\circ\text{C}$ .

**Note 4:** The maximum power dissipation is a function of  $T_{J(MAX)}$ ,  $\theta_{JA}$ , and  $T_A$ . The maximum allowable power dissipation at any ambient temperature is  $P_D = (T_{J(MAX)} - T_A)/\theta_{JA}$ . All numbers apply for packages soldered directly into a PC board.

**Note 5:** Typical values represent the most likely parametric norm as determined at the time of characterization. Actual typical values may vary over time and will also depend on the application and configuration. The typical values are not tested and are not guaranteed on shipped production material.

**Note 6:** All limits are guaranteed by testing or statistical analysis.

**Note 7:** CMRR measured at  $V_{CM} = 0\text{V}$  to  $2.5\text{V}$  and  $2.5\text{V}$  to  $5\text{V}$  when  $V_S = 5\text{V}$ ,  $V_{CM} = 0.2\text{V}$  to  $1.35\text{V}$  and  $1.35\text{V}$  to  $2.7\text{V}$  when  $V_S = 2.7\text{V}$ . This eliminates units that have large  $V_{OS}$  at the  $V_{CM}$  extremes and low or opposite  $V_{OS}$  at  $V_{CM} = V_S/2$ .

**Note 8:** All measurements made at  $10\text{ kHz}$ . A  $100\text{ k}\Omega$  pull-up resistor was used when measuring the LMC7225.  $C_{LOAD} = 50\text{ pF}$  including the test jig and scope probe. The rise times of the LMC7225 are a function of the R-C time constant.

**Note 9:** Input step voltage for the propagation measurements is  $100\text{ mV}$ .

**Note 10:** Do not short the output of the LMC7225 to voltages greater than  $10\text{V}$  or damage may occur.

**Typical Performance Characteristics**  $T_A = 25^\circ\text{C}$  unless otherwise specified

**Supply Current vs. Supply Voltage**

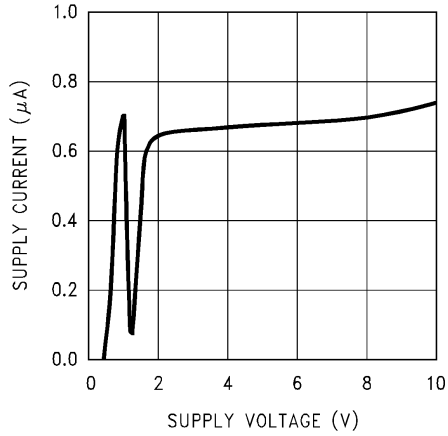

01285303

**Prop Delay vs.  $V_{\text{SUPPLY}}$**

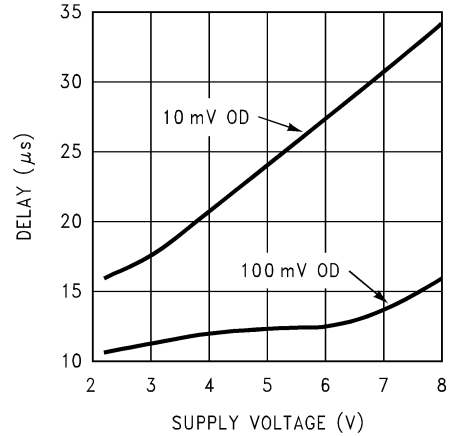

01285312

**Prop Delay vs. Overdrive**

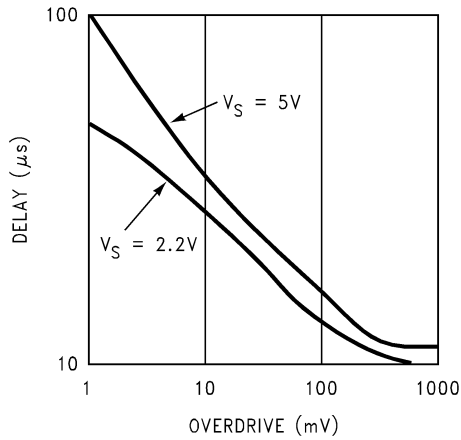

01285313

**Short Circuit Current vs.  $V_{\text{SUPPLY}}$**

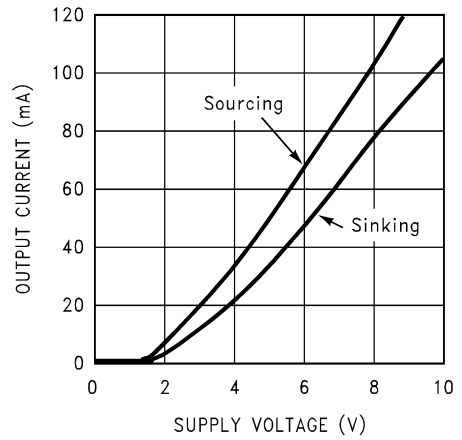

01285314

**Output Voltage vs. Output Current  
LMC7215**

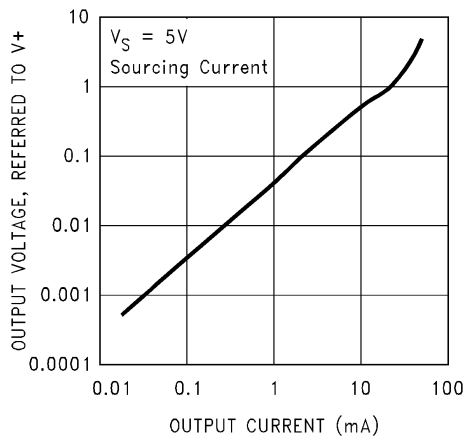

01285315

**Output Voltage vs. Output Current**

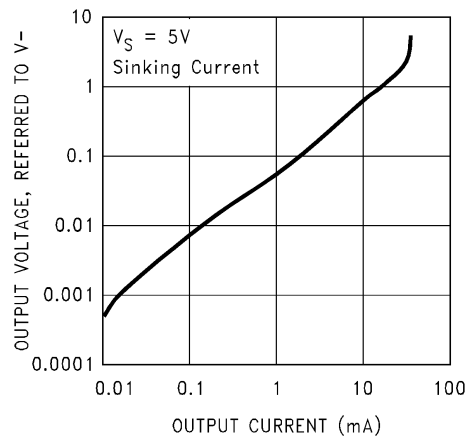

01285316

**Typical Performance Characteristics**  $T_A = 25^\circ\text{C}$  unless otherwise specified (Continued)

**Output Voltage vs. Output Current**  
**LMC7215**

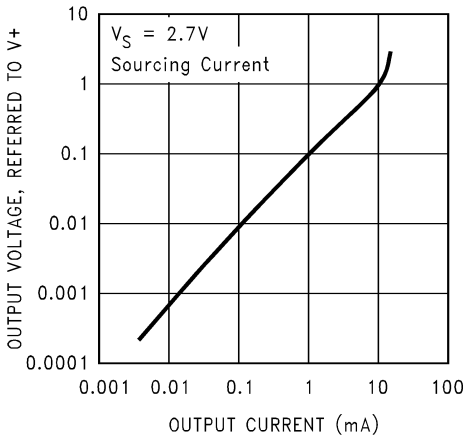

**Output Voltage vs. Output Current**

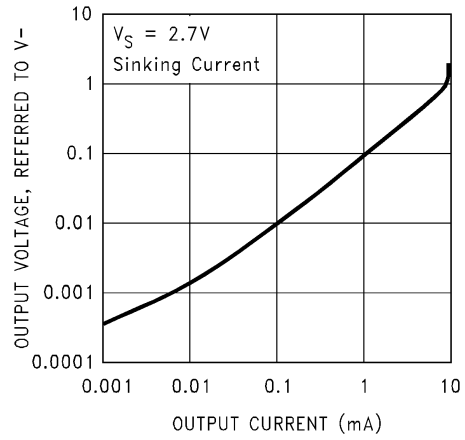

**Output Leakage Current vs. Output Voltage**  
**LMC7225**

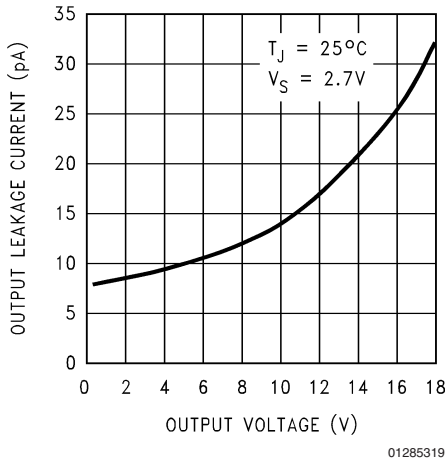

**Output Leakage Current vs. Output Voltage**  
**LMC7225**

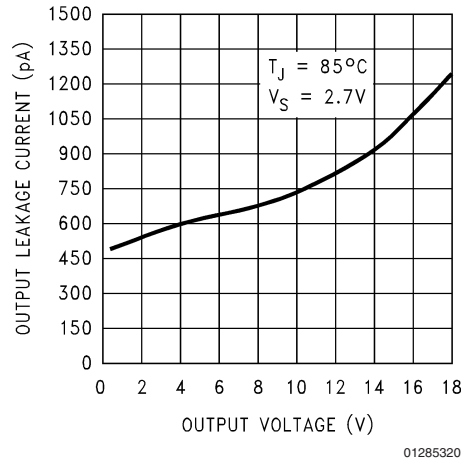

## Application Information

### RESPONSE TIME

Depending upon the amount of overdrive, the delay will typically be between 10  $\mu$ s to 200  $\mu$ s. The curve showing delay vs. overdrive in the "Typical Characteristics" section shows the delay time when the input is preset with 100 mV across the inputs and then is driven the other way by 1 mV to 500 mV.

The transition from high to low or low to high is fast. Typically 1  $\mu$ s rise and 400 ns fall.

With a small signal input, the comparators will provide a square wave output from sine wave inputs at frequencies as high as 25 kHz. *Figure 1* shows a worst case example where a  $\pm 5$  mV sine wave is applied to the input. Note that the output is delayed by almost 180°.

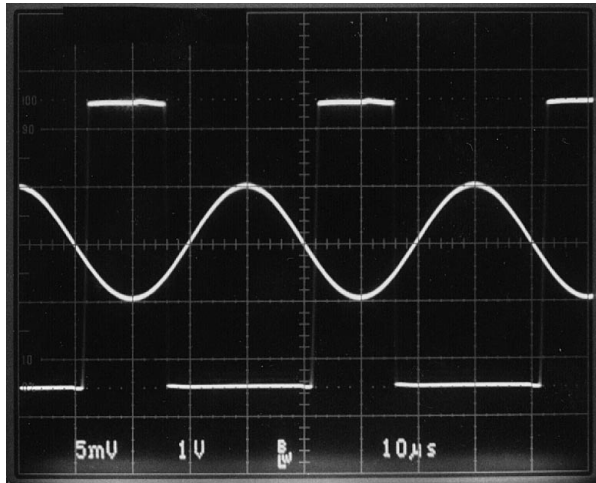

01285304

FIGURE 1.

### NOISE

Most comparators have rather low gain. This allows the output to spend time between high and low when the input signal changes slowly. The result is the output may oscillate between high and low when the differential input is near zero.

The exceptionally high gain of these comparators, 10,000 V/mV, eliminates this problem. Less than 1  $\mu$ V of change on the input will drive the output from one rail to the other rail.

If the input signal is noisy, the output cannot ignore the noise unless some hysteresis is provided by positive feedback.

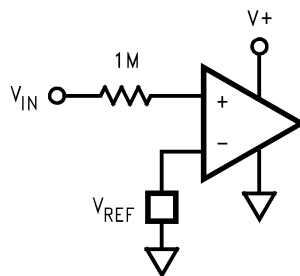

01285305

FIGURE 2.

### INPUT VOLTAGE RANGE

The LMC7215/25 have input voltage ranges that are larger than the supply voltage guarantees that signals from other parts of the system cannot overdrive the inputs. This allows sensing supply current by connecting one input directly to the  $V^+$  line and the other to the other side of a current sense resistor. The same is true if the sense resistor is in the ground return line.

Sensing supply voltage is also easy by connecting one input directly to the supply.

The inputs of these comparators are protected by diodes to both supplies. This protects the inputs from both ESD as well as signals that greatly exceed the supply voltages. As a result, current will flow through these forward biased diodes whenever the input voltage is more than a few hundred millivolts larger than the supplies. Until this occurs, there is essentially no input current. As a result, placing a large resistor in series with any input that may be exposed to large voltages, will limit the input current but have no other noticeable effect.

If the input current is limited to less than 5 mA by a series resistor, (see *Figure 2*), a threshold or zero crossing detector, that works with inputs from as low as a few millivolts to as high as 5,000V, is made with only one resistor and the comparator.

### INPUTS

As mentioned above, these comparators have near zero input current. This allows very high resistance circuits to be used without any concern for matching input resistances. This also allows the use of very small capacitors in R-C type timing circuits. This reduces the cost of the capacitors and amount of board space used.

### CAPACITIVE LOADS

The high output current drive allows large capacitive loads with little effect. Capacitive loads as large as 10,000 pF have no effect upon delay and only slow the transition by about 3  $\mu$ s.

### OUTPUT CURRENT

Even though these comparators use less than 1  $\mu$ A supply current, the outputs are able to drive very large currents.

The LMC7215 can source up to 50 mA when operated on a 5V supply. Both the LMC7215 and LMC7225 can sink over 20 mA. (See the graph of Max  $I_O$  vs.  $V_{SUPPLY}$  in the "Typical Characteristics" section.)

This large current handling ability allows driving heavy loads directly. LEDs, beepers and other loads can be driven easily.

The push-pull output stage of the LMC7215 is a very important feature. This keeps the total system power consumption to the absolute minimum. The only current consumed is the less than 1  $\mu$ A supply current and the current going directly into the load. No power is wasted in a pull-up resistor when the output is low. The LMC7225 is only recommended where a level shifting function from one logic level to another is desired, where the LMC7225 is being used as a drop-in lower power replacement for an older comparator or in circuits where more than one output will be paralleled.

## Application Information (Continued)

### POWER DISSIPATION

The large output current ability makes it possible to exceed the maximum operating junction temperature of 85°C and possibly even the absolute maximum junction temperature of 150°C.

The thermal resistance of the 8-pin SOIC package is 165°C/W. Shorting the output to ground with a 2.7V supply will only result in about 5°C rise above ambient.

The thermal resistance of the much smaller 5-Pin SOT23 package is 325°C/W. With a 2.7V supply, the raise is only 10.5°C but if the supply is 5V and the short circuit current is 50 mA, this will cause a raise of 41°C in the 8-Pin SOIC and 81°C in the 5-Pin SOT23. This should be kept in mind if driving very low resistance loads.

### SHOOT-THROUGH

Shoot-through is a common occurrence on digital circuits and comparators where there is a push-pull output stage. This occurs when a signal is applied at the same time to both the N-channel and P-channel output transistors to turn one off and turn the other on. (See Figure 3.) If one of the output devices responds slightly faster than the other, the fast one can be turned on before the other has turned off. For a very short time, this allows supply current to flow directly through both output transistors. The result is a short spike of current drawn from the supply.

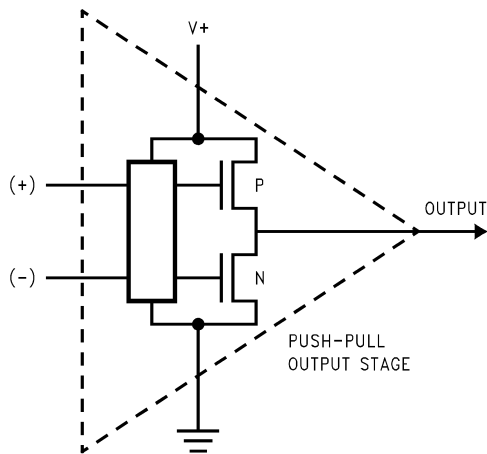

01285306

FIGURE 3.

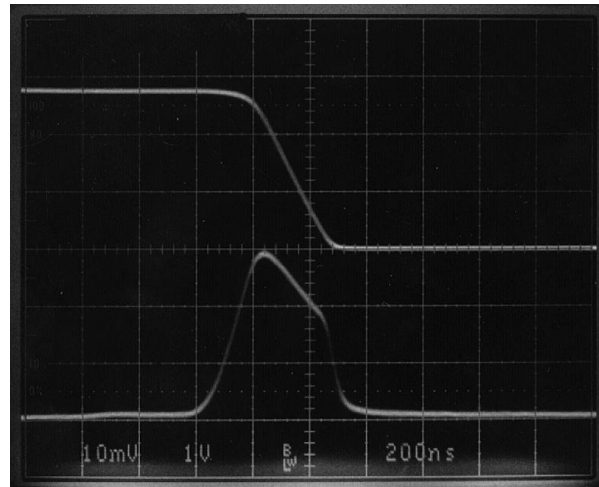

01285307

FIGURE 4.  $R_S = 100\Omega$

The LMC7215 produces a small current spike of 300  $\mu$ A peak for about 400 ns with 2.7V supply and 1.8 mA peak for 400 ns with a 5V supply. This spike only occurs when the output is going from high to low. It does not occur when going from low to high. Figure 4 and Figure 5 show what this current pulse looks like on 2.7V and 5V supplies. The upper trace is the output voltage and the lower trace is the supply current as measured with the circuit in Figure 6.

If the power supply has a very high impedance, a bypass capacitor of 0.01  $\mu$ F should be more than enough to minimize the effects of this small current pulse.

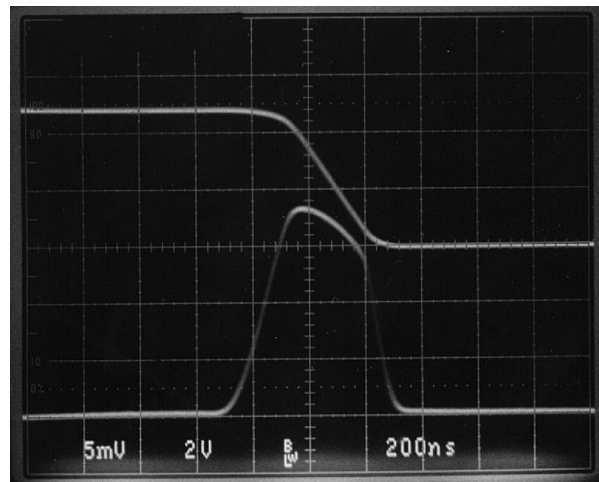

01285308

FIGURE 5.  $R_S = 10\Omega$

## Application Information (Continued)

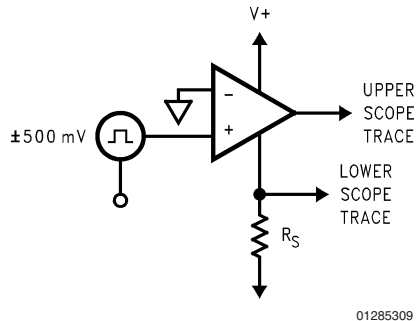

01285309

FIGURE 6.

### LATCH-UP

In the past, most CMOS IC's were susceptible to a damaging phenomena known as latch-up. This occurred when an ESD current spike or other large signal was applied to any of the pins of an IC. The LMC7215 and LMC7225 both are designed to make them highly resistant to this type of damage. They have passed qualification tests with input currents on any lead up to 300 mA at temperatures up to 125°C.

### SPICE MODELS

For a SPICE model of the LMC7215, LMC7225 and many other op amps and comparators, contact the NSC Customer Response Center at 800-272-9959 or on the World Wide Web at <http://www.national.com/models/index.html>.

## Ordering Information

Package	Part Number	Package Marking	Transport Media	NSC Drawing
8-Pin SOIC	LMC7215IM	LMC7215IM	95 Units/Rail	M08A
	LMC7215IMX		2.5k Units Tape and Reel	
5-Pin SOT23	LMC7215IM5	C02B	1k Units Tape and Reel	MF05A
	LMC7215IM5X		3k Units Tape and Reel	
	LMC7225IM5	C03B	1k Units Tape and Reel	
	LMC7225IM5X		3k Units Tape and Reel	

## SOT-23-5 Tape and Reel Specification

### REEL DIMENSIONS

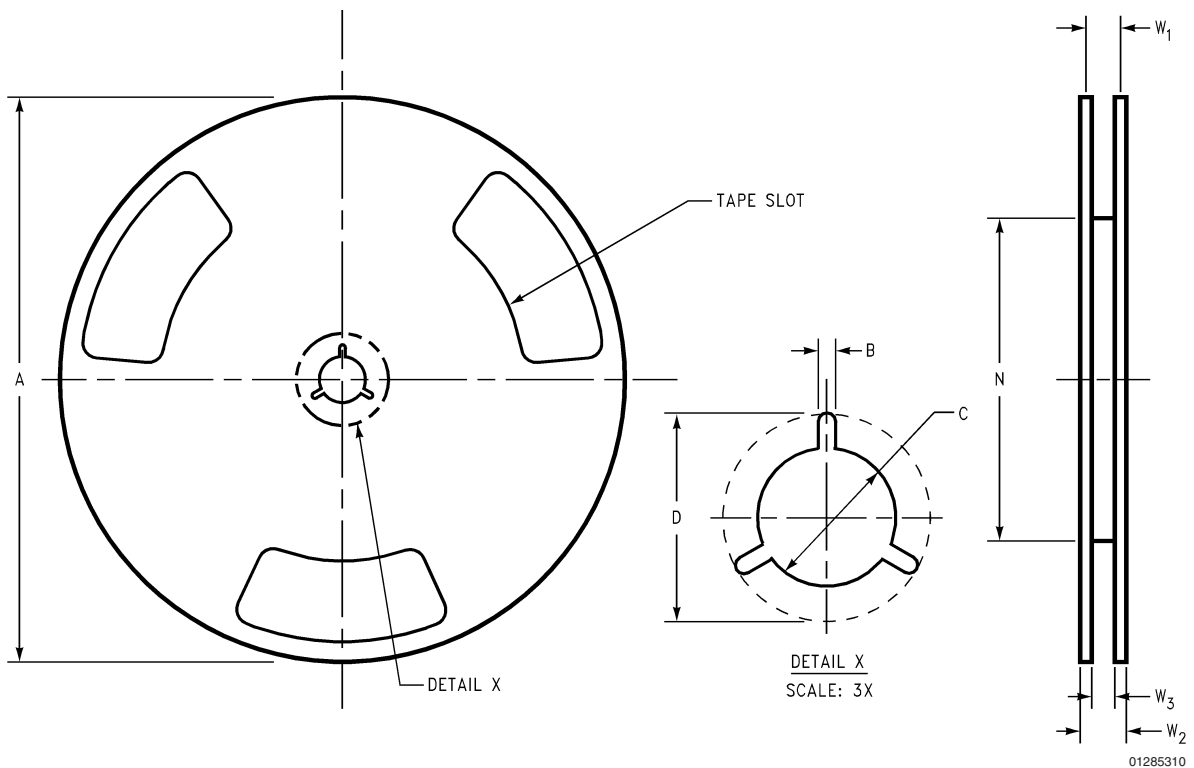

01285310

8 mm	7.00	0.059	0.512	0.795	2.165	0.331 + 0.059/-0.000	0.567	W1 + 0.078/-0.039
	330.00	1.50	13.00	20.20	55.00	8.40 + 1.50/-0.00	14.40	W1 + 2.00/-1.00
Tape Size	A	B	C	D	N	W1	W2	W3



# SOT-23-5 Tape and Reel Specification (Continued)

## TAPE FORMAT

Tape Section	# Cavities	Cavity Status	Cover Tape Status
Leader (Start End)	0 (min)	Empty	Sealed
	75 (min)	Empty	Sealed
Carrier	3000	Filled	Sealed
	1000	Filled	Sealed
Trailer (Hub End)	125 (min)	Empty	Sealed
	0 (min)	Empty	Sealed

## TAPE DIMENSIONS

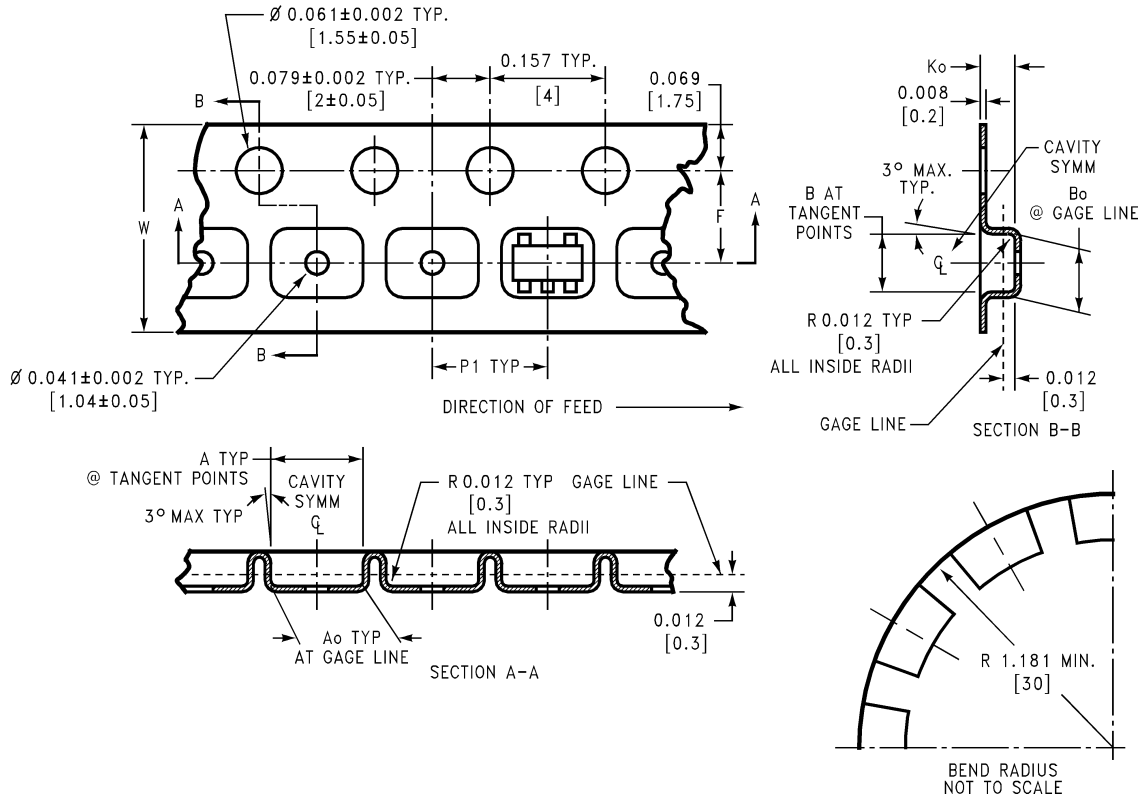

01285311

<b>8 mm</b>	<b>0.130</b>	<b>0.124</b>	<b>0.130</b>	<b>0.126</b>	<b>0.138 ± 0.002</b>	<b>0.055 ± 0.004</b>	<b>0.157</b>	<b>0.315 ± 0.012</b>
	<b>(3.3)</b>	<b>(3.15)</b>	<b>(3.3)</b>	<b>(3.2)</b>	<b>(3.5 ± 0.05)</b>	<b>(1.4 ± 0.11)</b>	<b>(4)</b>	<b>(8 ± 0.3)</b>
Tape Size	DIM A	DIM A <sub>o</sub>	DIM B	DIM B <sub>o</sub>	DIM F	DIM K <sub>o</sub>	DIM P1	DIM W

**Physical Dimensions** inches (millimeters) unless otherwise noted

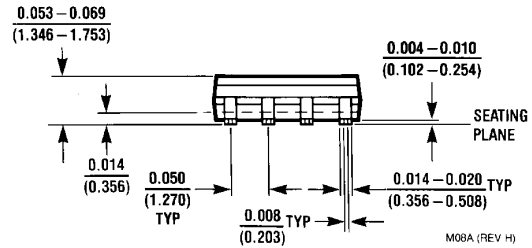
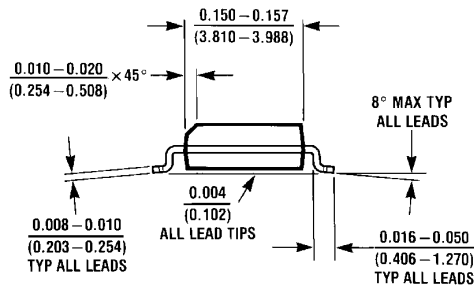
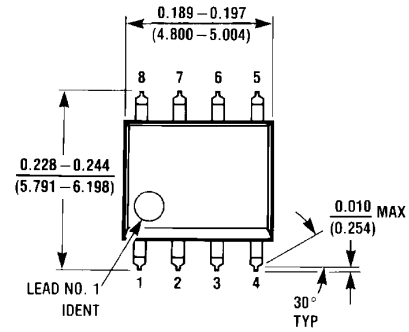

**8-Pin SOIC**  
**NS Package Number M08A**

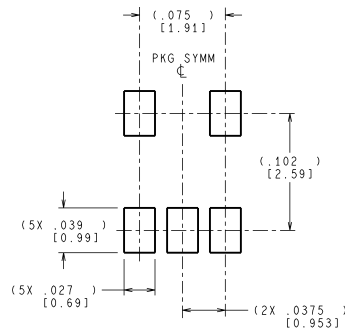
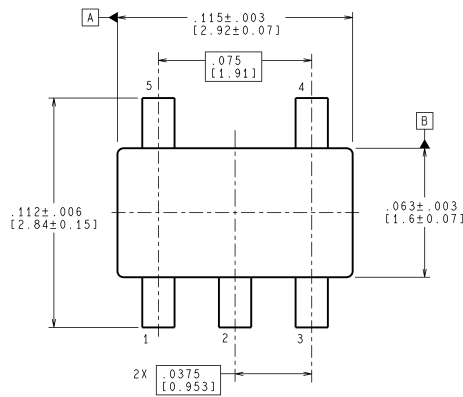

**LAND PATTERN RECOMMENDATION**

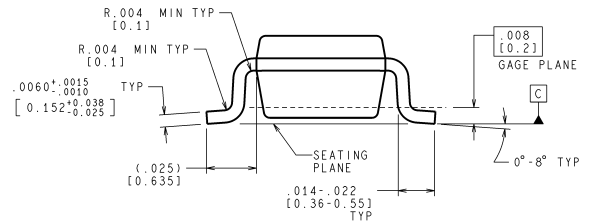
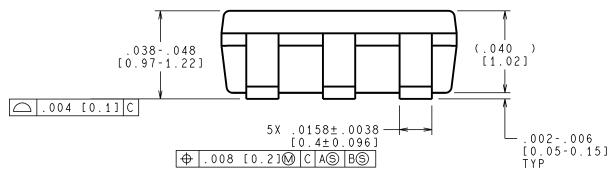

CONTROLLING DIMENSION IS INCH  
VALUES IN [ ] ARE MILLIMETERS  
DIMENSIONS IN ( ) FOR REFERENCE ONLY

MF05A (Rev C)

**5-Pin SOT23**  
**NS Package Number MF05A**

## Notes

National does not assume any responsibility for use of any circuitry described, no circuit patent licenses are implied and National reserves the right at any time without notice to change said circuitry and specifications.

For the most current product information visit us at [www.national.com](http://www.national.com).

### LIFE SUPPORT POLICY

NATIONAL'S PRODUCTS ARE NOT AUTHORIZED FOR USE AS CRITICAL COMPONENTS IN LIFE SUPPORT DEVICES OR SYSTEMS WITHOUT THE EXPRESS WRITTEN APPROVAL OF THE PRESIDENT AND GENERAL COUNSEL OF NATIONAL SEMICONDUCTOR CORPORATION. As used herein:

1. Life support devices or systems are devices or systems which, (a) are intended for surgical implant into the body, or (b) support or sustain life, and whose failure to perform when properly used in accordance with instructions for use provided in the labeling, can be reasonably expected to result in a significant injury to the user.
2. A critical component is any component of a life support device or system whose failure to perform can be reasonably expected to cause the failure of the life support device or system, or to affect its safety or effectiveness.

### BANNED SUBSTANCE COMPLIANCE

National Semiconductor follows the provisions of the Product Stewardship Guide for Customers (CSP-9-111C2) and Banned Substances and Materials of Interest Specification (CSP-9-111S2) for regulatory environmental compliance. Details may be found at: [www.national.com/quality/green](http://www.national.com/quality/green).

Lead free products are RoHS compliant.



**National Semiconductor**  
Americas Customer  
Support Center  
Email: [new.feedback@nsc.com](mailto:new.feedback@nsc.com)  
Tel: 1-800-272-9959

[www.national.com](http://www.national.com)

**National Semiconductor**  
Europe Customer Support Center  
Fax: +49 (0) 180-530 85 86  
Email: [europe.support@nsc.com](mailto:europe.support@nsc.com)  
Deutsch Tel: +49 (0) 69 9508 6208  
English Tel: +44 (0) 870 24 0 2171  
Français Tel: +33 (0) 1 41 91 8790

**National Semiconductor**  
Asia Pacific Customer  
Support Center  
Email: [ap.support@nsc.com](mailto:ap.support@nsc.com)

**National Semiconductor**  
Japan Customer Support Center  
Fax: 81-3-5639-7507  
Email: [jpn.feedback@nsc.com](mailto:jpn.feedback@nsc.com)  
Tel: 81-3-5639-7560