

LM8365

Micropower Undervoltage Sensing Circuits with Programmable Output Delay

General Description

The LM8365 series are micropower undervoltage sensing circuits that are ideal for use in battery powered microprocessor based systems, where extended battery life is a key requirement.

A range of threshold voltages from 2.0V to 4.5V are available with an active low, open drain or CMOS, output. These devices feature a very low quiescent current of 0.65µA typical. The LM8365 series features a highly accurate voltage reference, a comparator with precise thresholds and built-in hysteresis to prevent erratic reset operation, a time delayed output which can be programmed by the system designer, and guaranteed Reset operation down to 1.0V with extremely low standby current.

These devices are available in the space saving 5-Pin SOT23 surface mount package. For additional undervoltage thresholds and output options, please contact National Semiconductor.

Features

- Extremely Low Quiescent Current: 0.65µA, at $V_{IN} = 2.87V$
- High Accuracy Threshold Voltage ($\pm 2.5\%$)
- Complementary or Open Drain Output
- Programmable output delay by external Capacitor (100ms typ with 0.1µF)
- Input Voltage Range: 1V to 6V
- Surface Mount Package (5-Pin SOT23)
- Pin for pin compatible with MC33465

Applications

- Low Battery Detection
- Microprocessor Reset Controller
- Power Fail Indicator
- Battery Backup Detection

Functional Diagrams

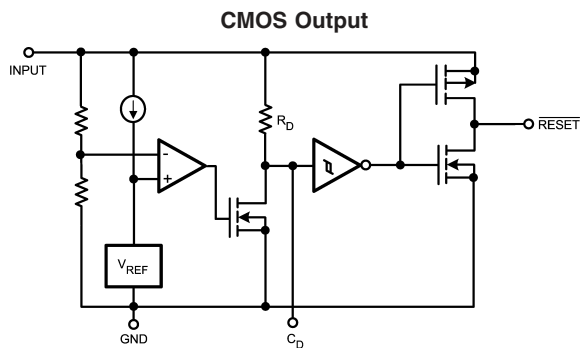

20066013

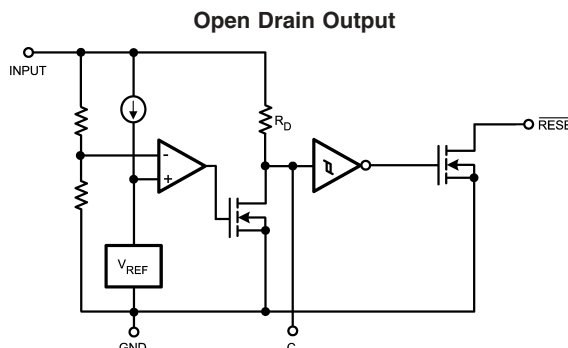

20066014

Connection Diagram

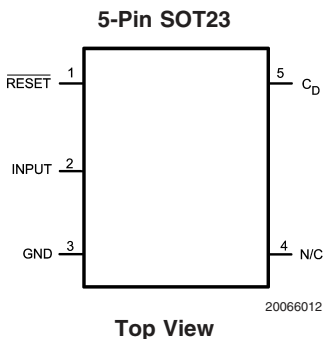

20066012

Pin Description

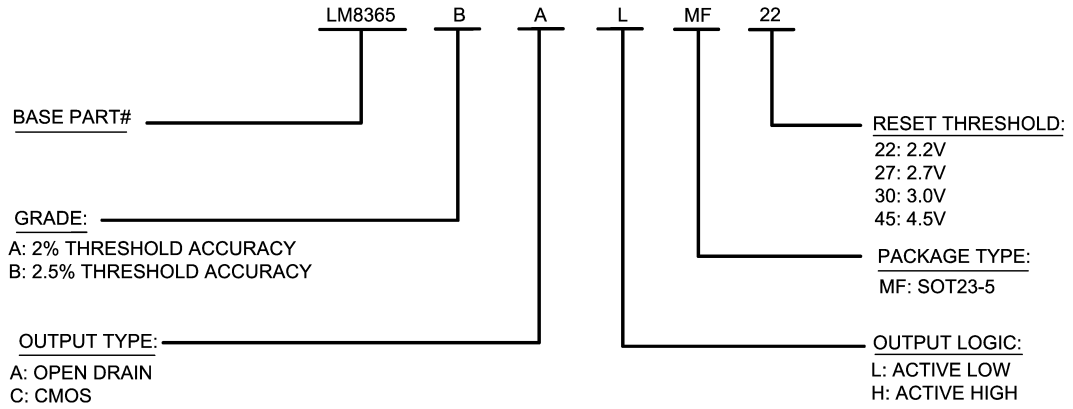

20066015

Ordering Information

Package	Part Number	Package Marking	Threshold	Output Type	Transport Media	NSC Drawing
5-Pin SOT23	LM8365BALMF22	F08A	2.2V	Open Drain, Active Low	1k Units Tape and Reel	MF05A
	LM8365BALMFX22				3k Units Tape and Reel	
	LM8365BALMF27	F07A	2.7V	Open Drain, Active Low	1k Units Tape and Reel	
	LM8365BALMFX27				3k Units Tape and Reel	
	LM8365BCLMF30	F02A	3.0V	CMOS, Active Low	1k Units Tape and Reel	
	LM8365BCLMFX30				3k Units Tape and Reel	
	LM8365BALMF45	F06A	4.5V	Open Drain, Active Low	1k Units Tape and Reel	
	LM8365BALMFX45				3k Units Tape and Reel	

Absolute Maximum Ratings (Note 1)

If Military/Aerospace specified devices are required, please contact the National Semiconductor Sales Office/Distributors for availability and specifications.

Supply Voltage	-0.3V to 6.5V
$\overline{\text{RESET}}$ Output Voltage	-0.3V to 6.5V
$\overline{\text{RESET}}$ Output Current	70mA
Storage Temperature Range	-65°C to 150°C
Mounting Temperature	
Lead Temp. (Soldering 10 sec)	260°C

Junction Temperature

125°C

Operating Ratings (Note 1)

Temperature Range	-40°C to 85°C
Thermal Resistance to Ambient (θ_{JA})	265°C/W
ESD Tolerance	
Human Body Model	2000V
Machine Model	200V

Electrical Characteristics

Unless otherwise specified, all limits guaranteed for $T_A = 25^\circ\text{C}$.

Symbol	Parameter	Conditions	Min (Note 3)	Typ (Note 2)	Max (Note 3)	Units
$V_{\text{DET-}}$	Detector Threshold Voltage	High to Low State Output (V_{IN} Decreasing)				V
		22 Suffix	2.145	2.2	2.255	
		27 Suffix	2.633	2.7	2.767	
		30 Suffix	2.925	3.0	3.075	
V_{HYS}	Detector Threshold Hysteresis	V_{IN} Increasing				V
		22 Suffix	0.066	0.110	0.154	
		27 Suffix	0.081	0.135	0.189	
		30 Suffix	0.090	0.150	0.210	
$\Delta V_{\text{det}}/\Delta T$	Detector Threshold Voltage Temperature Coefficient			± 100		PPM/°C
V_{OH} V_{OL}	$\overline{\text{RESET}}$ Output Voltage	(CMOS Output: $I_{\text{SOURCE}} = 1\text{mA}$) (Open Drain or CMOS Output: $I_{\text{SINK}} = 1\text{mA}$)	$V_{\text{IN}} - 2.1$	$V_{\text{IN}} - 1.0$ 0.25	V_{IN} 0.5	V
I_{OL}	$\overline{\text{RESET}}$ Output Sink Current	$V_{\text{IN}} = 1.5\text{V}$, $V_{\text{OL}} = 0.5\text{V}$	1.0	2.5		mA
I_{OH}	$\overline{\text{RESET}}$ Output Source Current	$V_{\text{IN}} = 4.5\text{V}$, $V_{\text{OL}} = 2.4\text{V}$	1.0	7.0		mA
I_{CD}	Delay Pin Output Sink Current	$V_{\text{IN}} = 1.5\text{V}$, $V_{\text{CD}} = 0.5\text{V}$	0.2	1.8		mA
R_{D}	Delay Resistance		0.5	1.0	2.0	M Ω
V_{IN}	Operating Input Voltage Range		1.0		6.0	V
I_{IN}	Quiescent Input Current	22 Suffix				μA
		$V_{\text{IN}} = 2.10\text{V}$		0.57	0.8	
		$V_{\text{IN}} = 4.20\text{V}$		0.71	1.3	
		27 Suffix				
		$V_{\text{IN}} = 2.60\text{V}$		0.62	0.9	
		$V_{\text{IN}} = 4.70\text{V}$		0.75	1.3	
		30 Suffix				
		$V_{\text{IN}} = 2.87\text{V}$		0.65	0.9	
		$V_{\text{IN}} = 5.00\text{V}$		0.77	1.3	
		45 Suffix				
$V_{\text{IN}} = 4.34\text{V}$		0.70	1.0			
$V_{\text{IN}} = 6.00\text{V}$		0.85	1.4			

Note 1: Absolute Maximum Ratings indicate limits beyond which damage to the device may occur. Operating Ratings indicate conditions for which the device is intended to be functional, but specific performance is not guaranteed. For guaranteed specifications and the test conditions, see the Electrical Characteristics.

Note 2: Typical values represent the most likely parametric norm.

Note 3: All limits are guaranteed by testing or statistical analysis.

Typical Performance Characteristics

Input Current vs. Input Voltage
LM8365BALMF45

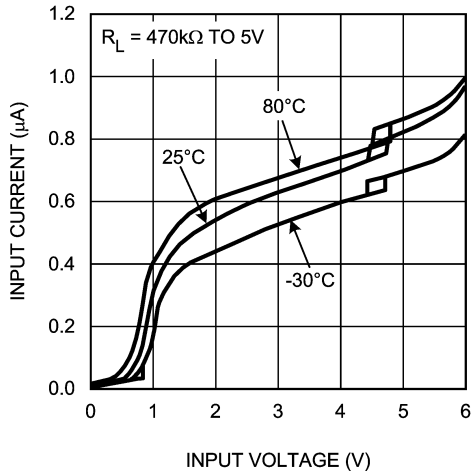

20066001

Reset Output Voltage vs. Input Voltage
LM8365BALMF45

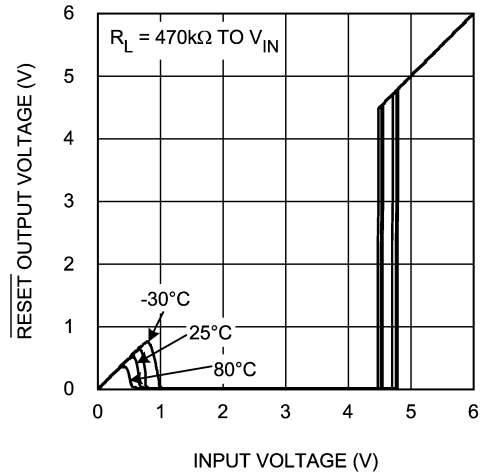

20066002

Reset Output Sink Current vs. Input Voltage
LM8365BALMF27

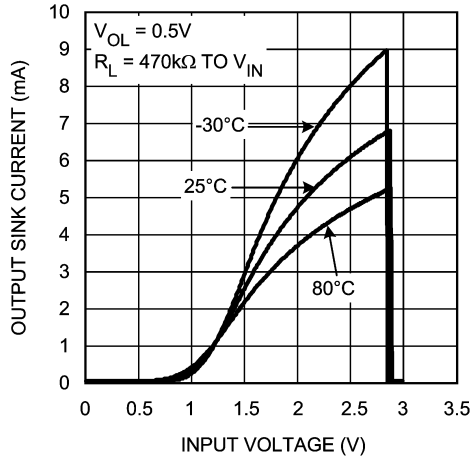

20066003

Reset Output Source Current vs. Input Voltage
LM8365BCLMF30

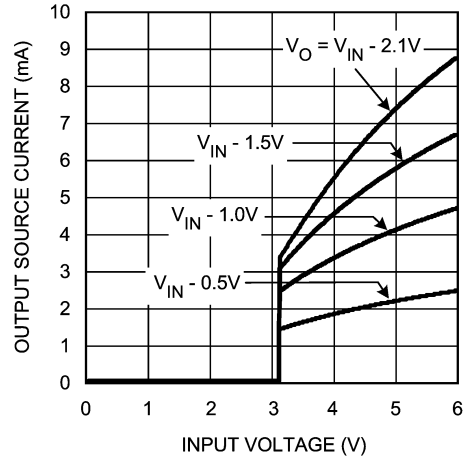

20066004

Reset Output Sink Current vs. Reset Output Voltage
LM8365BALMF45

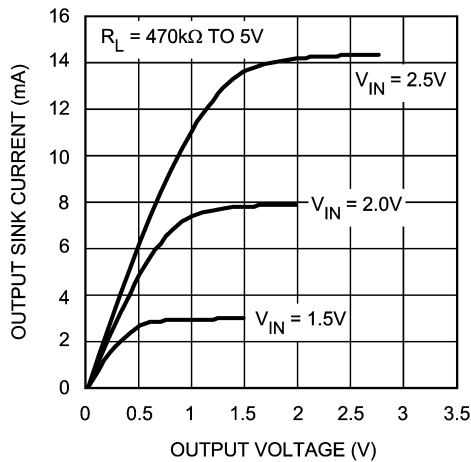

20066005

CD Sink Current vs. Input Voltage
LM8365BALMF27

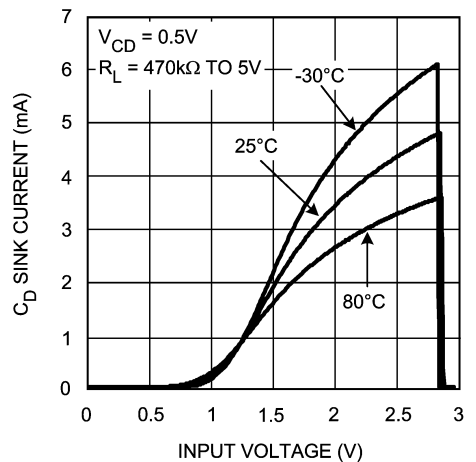

20066006

Typical Performance Characteristics (Continued)

C_D Sink Current vs. C_D Voltage

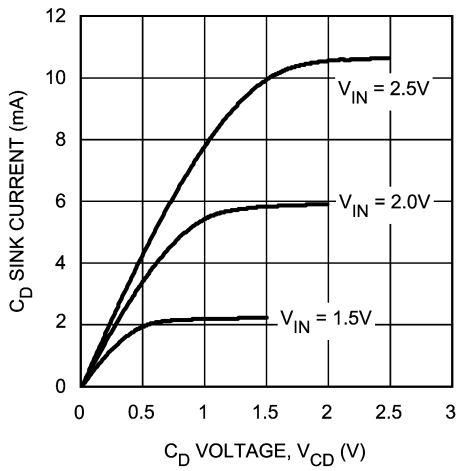

20066007

**C_D Delay Pin Threshold Voltage vs. Temperature
LM8365BALMF27**

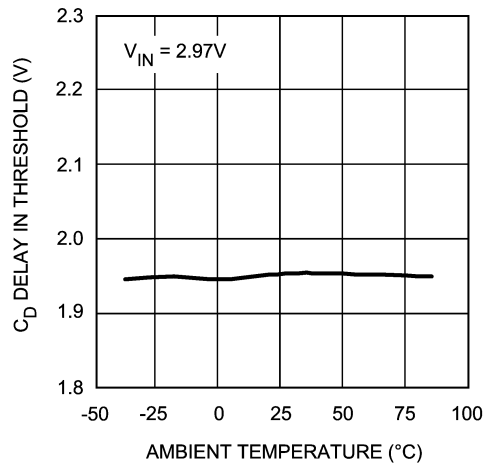

20066008

**Detector Threshold Voltage vs. Temperature
LM8365BALMF45**

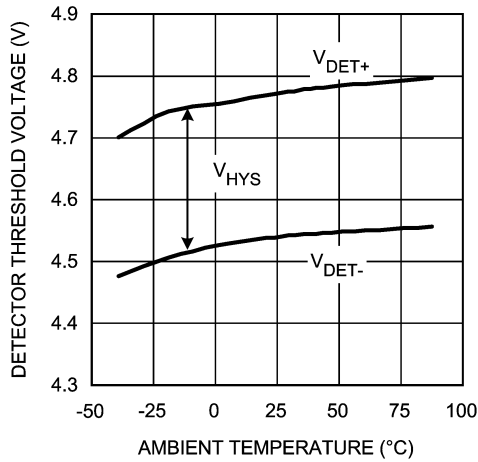

20066009

Delay Resistance vs. Temperature

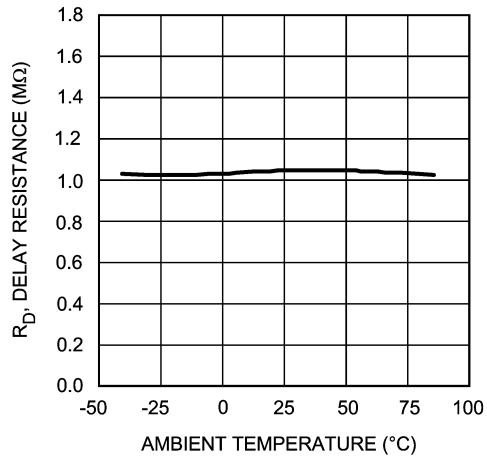

20066010

Output Time Delay vs. Capacitance

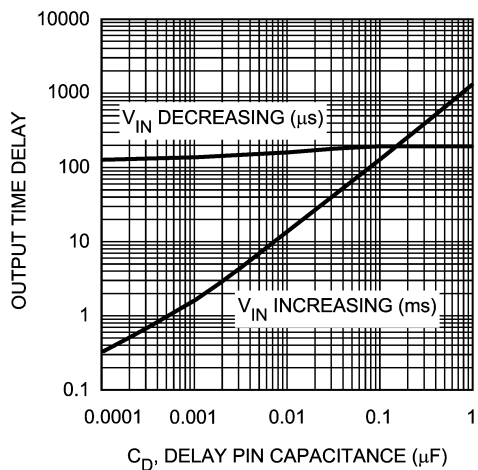

20066011

Application Notes

The propagation delay time for the LM8365 is measured using a 470k Ω pull-up resistor connected to from the RESET output pin to 5V in addition to a 10pF capacitive load connected from the same pin to GND. *Figure 1* shows the timing

diagram for the measurement for the propagation delay. V_{DET+} is equal to the sum of the detector threshold, V_{DET-} , and the built in hysteresis, V_{HYS} . t_{D1} is the propagation time from High-to-Low and t_{D2} is the propagation from Low-to-High.

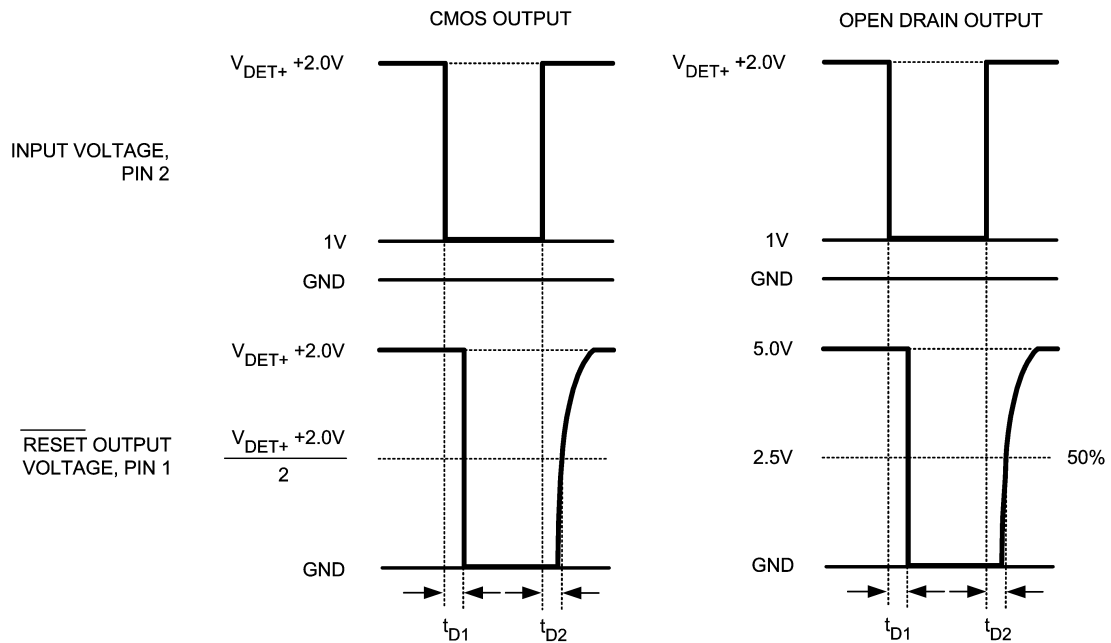

20066016

FIGURE 1. Propagation Delay Timing Diagrams

The LM8365 ultra-low current voltage detector was designed to monitor voltages and to provide an indication when the monitored voltage, V_{IN} , dropped below a precisely trimmed threshold voltage. The voltage detector of the LM8365 drives a time delay generator that may be programmed for fixed lengths of time depending on the application needs. This characteristic is displayed in the typical operating timing diagram in *Figure 2*. V_{IN} is the voltage that is being monitored and as it decreases passed the precisely trimmed threshold V_{DET-} the Active Low RESET output drops to a Logic Low state and the C_D pin drops to 0V. During this state the external capacitor connected to the C_D pin is immediately discharged by an internal N-Channel MOSFET. When V_{IN} increases above the threshold V_{DET+} ($V_{DET-} + V_{HYS}$) the capacitor connected to the C_D pin starts to charge up to V_{IN}

through an internal pull-up resistor R_D . Once the capacitor has charged up past the internal Delay Pin Threshold, which is typically 0.675 V_{IN} , the RESET output will revert back to its original state. The LM8365 has built-in hysteresis to help prevent erratic reset operation when the input voltage crosses the threshold.

The LM8365 has a wide variety of applications that can take advantage of its precision and low current consumption to monitor Input voltages even though it was designed as a reset controller in portable microprocessor based systems. It is a very cost effective and space saving device that will protect your more expensive investments of microprocessors and other devices that need a guaranteed supply voltage and time delay for proper operation.

Application Notes (Continued)

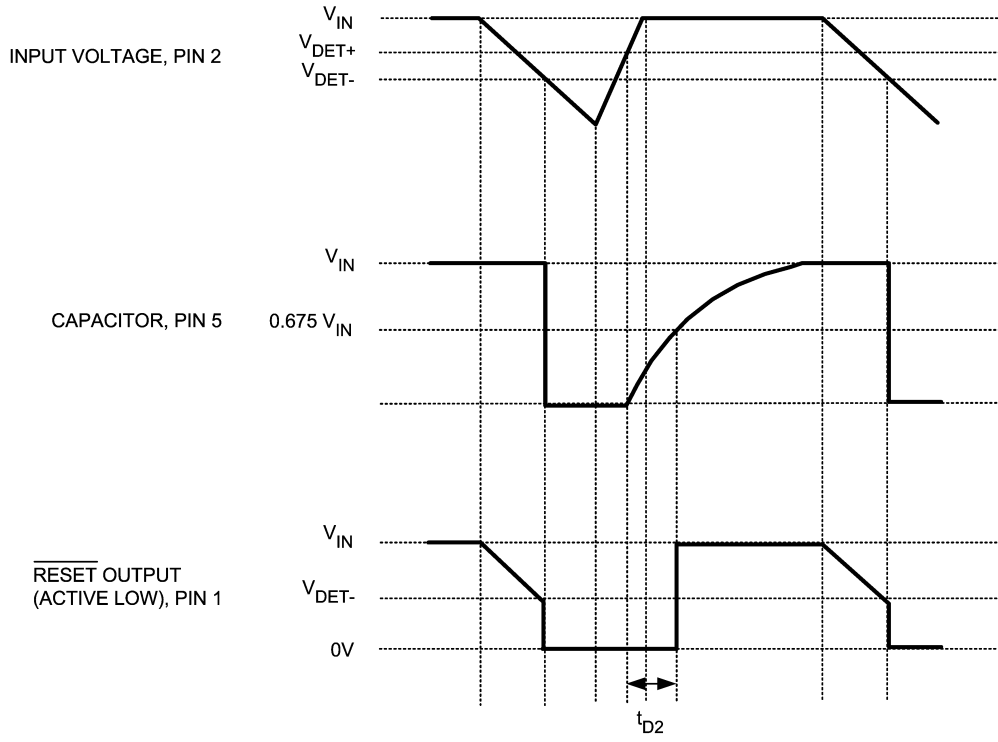

20066017

FIGURE 2. Timing Waveforms

Typical Applications

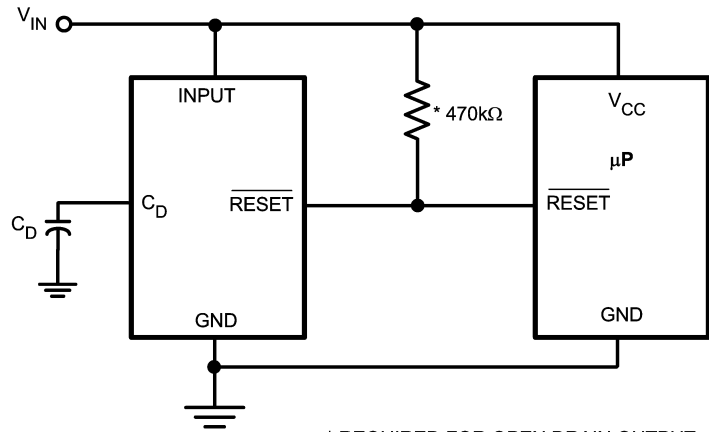

* REQUIRED FOR OPEN DRAIN OUTPUT

20066018

Microprocessor $\overline{\text{RESET}}$ Circuit

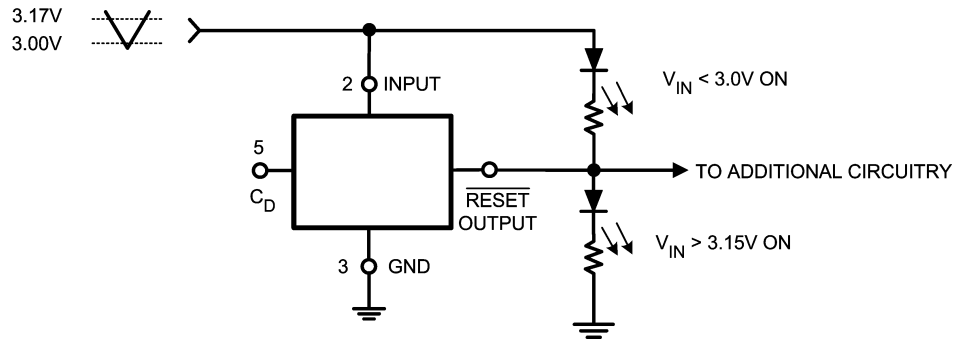

20066019

Battery Charge Indicator Using LM8365BCLMF30

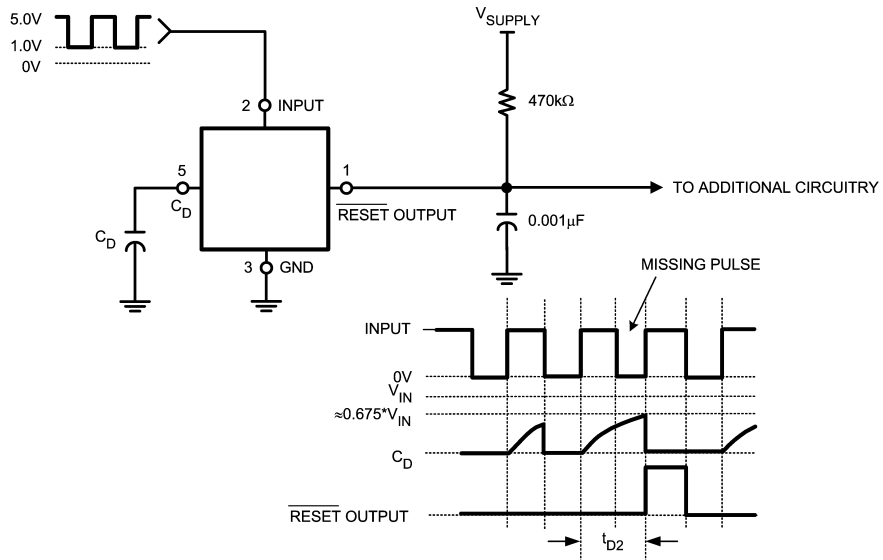

20066020

Missing Pulse Detector or Frequency Detector Using LM8365BALMF45

Physical Dimensions inches (millimeters)

unless otherwise noted

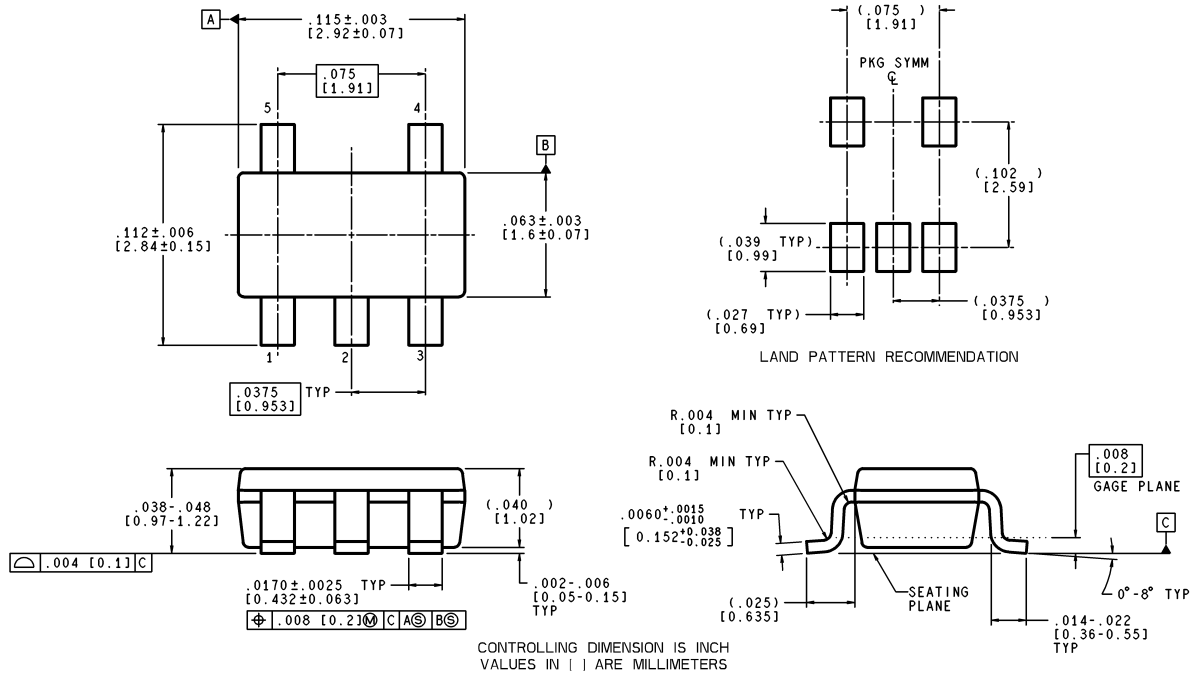

MF05A (Rev A)

**5-Pin SOT23-5
NSC Package Number MF05A**

LIFE SUPPORT POLICY

NATIONAL'S PRODUCTS ARE NOT AUTHORIZED FOR USE AS CRITICAL COMPONENTS IN LIFE SUPPORT DEVICES OR SYSTEMS WITHOUT THE EXPRESS WRITTEN APPROVAL OF THE PRESIDENT AND GENERAL COUNSEL OF NATIONAL SEMICONDUCTOR CORPORATION. As used herein:

1. Life support devices or systems are devices or systems which, (a) are intended for surgical implant into the body, or (b) support or sustain life, and whose failure to perform when properly used in accordance with instructions for use provided in the labeling, can be reasonably expected to result in a significant injury to the user.
2. A critical component is any component of a life support device or system whose failure to perform can be reasonably expected to cause the failure of the life support device or system, or to affect its safety or effectiveness.



National Semiconductor
Americas Customer
Support Center
Email: new.feedback@nsc.com
Tel: 1-800-272-9959

National Semiconductor
Europe Customer Support Center
Fax: +49 (0) 180-530 85 86
Email: europe.support@nsc.com
Deutsch Tel: +49 (0) 69 9508 6208
English Tel: +44 (0) 870 24 0 2171
Français Tel: +33 (0) 1 41 91 8790

National Semiconductor
Asia Pacific Customer
Support Center
Fax: +65-6250 4466
Email: ap.support@nsc.com
Tel: +65-6254 4466

National Semiconductor
Japan Customer Support Center
Fax: 81-3-5639-7507
Email: jpn.feedback@nsc.com
Tel: 81-3-5639-7560

www.national.com