

LM71

SPI/MICROWIRE 13-Bit Plus Sign Temperature Sensor

General Description

The LM71 is a low-power, high-resolution digital temperature sensor with an SPI and MICROWIRE compatible interface, available in the 5-pin SOT23 or the 6-pin LLP (no pull back) package. The host can query the LM71 at any time to read temperature. Its low operating current is useful in systems where low power consumption is critical.

The LM71 has 13-bit plus sign temperature resolution (0.03125°C per LSB) while operating over a temperature range of -40°C to +150°C.

The LM71's 2.65V to 5.5V supply voltage range, fast conversion rate, low supply current, and simple SPI interface make it ideal for a wide range of applications.

Applications

- System Thermal Management
- Personal Computers
- Portable Electronic Devices
- Disk Drives
- Office Electronics

- Electronic Test Equipment
- Vending Machines

Features

- SOT23-5 or No-Pull-Back LLP-6 Packages
- Operates over a full -40°C to +150°C range
- SPI and MICROWIRE Bus interface

Key Specifications

■ Supply Voltage		2.65V to 5.5V
■ Supply Current	operating	300 μ A (typ) 550 μ A (max)
■ Temperature Accuracy	-10°C to +65°C	$\pm 1.5^\circ$ C (max)
	-40°C to 150°C	+3/- 2°C (max)
■ Temperature Resolution		31.25 m°C

Simplified Block Diagram

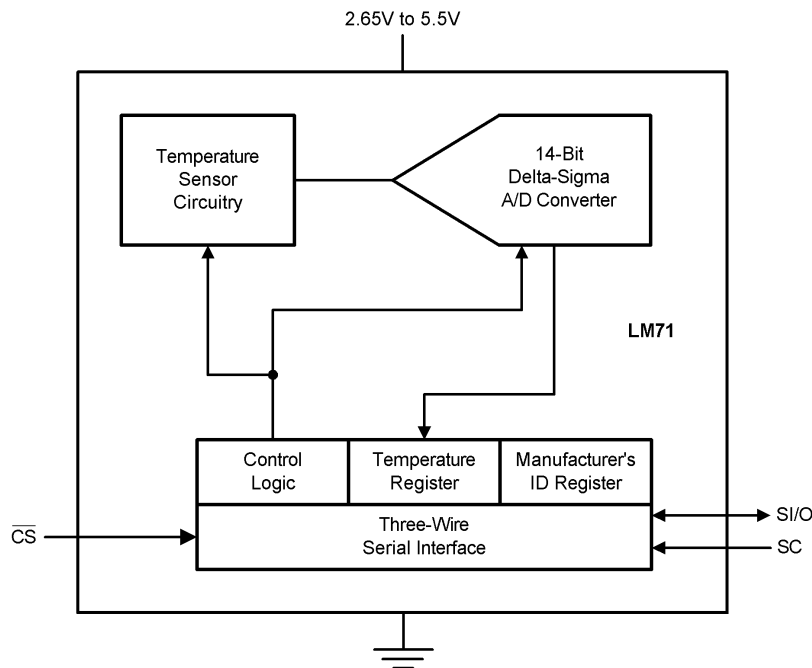

20031701

Connection Diagrams

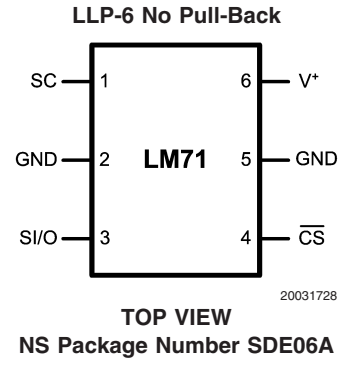
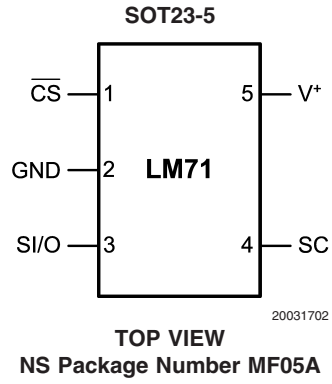

Ordering Information

Order Number	Package Marking	NS Package Number	Supply Voltage	Transport Media
LM71CIMF	T16C	MF05A	2.65V to 5.5V	3000 Units in Tape and Reel
LM71CISD	LM71C	SDE06A	2.65V to 5.5V	4500 Units in Tape and Reel

Pin Descriptions

Label	Pin Number		Function	Typical Connection
	SOT23-5	LLP-6		
$\overline{\text{CS}}$	1	4	Chip Select input	From controller
GND	2	2, 5	Power Supply Ground	Connect all GND Pins to ground
SI/O	3	3	Slave Input/Output - Serial bus bi-directional data line. Shmitt trigger input.	From and to controller
SC	4	1	Slave Clock - Serial bus clock Shmitt trigger input line	From controller
V ⁺	5	6	Positive Supply Voltage Input	DC voltage from 2.65V to 5.5V. Bypass with a 0.1 μF ceramic capacitor.

Typical Application

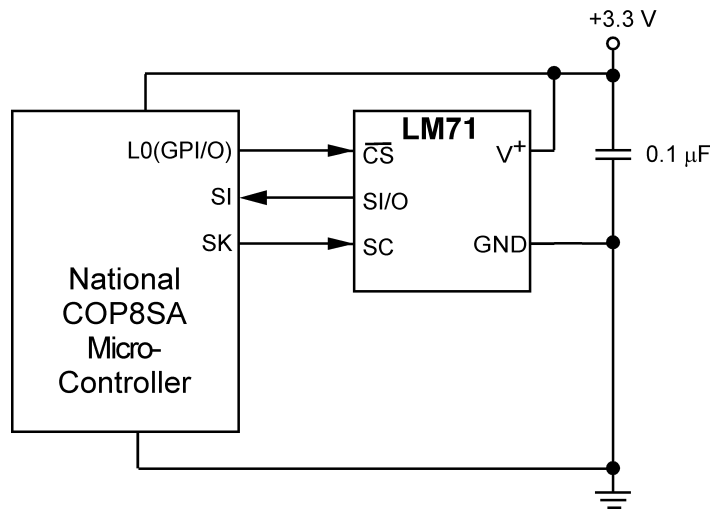

20031703

FIGURE 1. COP Microcontroller Interface

Absolute Maximum Ratings (Note 1)

Supply Voltage	-0.3V to 6.0V
Voltage at any Pin	-0.3V to V ⁺ + 0.3V
Input Current at any Pin (Note 2)	5 mA
Storage Temperature	-65°C to +150°C
Soldering Information, Lead Temperature	
SOT23-5 Package (Note 3)	
Vapor Phase (60 seconds)	215°C
Infrared (15 seconds)	220°C
LLP-6 Package (Note 3)	
Infrared (5 seconds)	215°C

ESD Susceptibility (Note 4)

Human Body Model	2000V
Machine Model	200V

Operating Ratings

Specified Temperature Range (Note 5)	T _{MIN} to T _{MAX}
LM71CIMF, LM71CISD	-40°C to +150°C
Supply Voltage Range (+V _S)	
LM71CIMF, LM71CISD	+2.65V to +5.5V

Temperature-to-Digital Converter Characteristics Unless otherwise noted, these specifications apply for V⁺ = 2.65V to 3.6V (Note 6). **Boldface limits apply for T_A = T_J = T_{MIN} to T_{MAX}**; all other limits T_A = T_J = +25°C, unless otherwise noted.

Parameter	Conditions	Typical (Note 7)	LM71CIMF LM71CISD Limits (Note 8)	Units (Limit)
Temperature Error (Note 6)	T _A = -10°C to +65°C		±1.5	°C (max)
	T _A = -40°C to +85°C		±2.0	°C (max)
	T _A = -40°C to +150°C		+3/-2	°C (max)
Resolution		14 0.03125		Bits °C
Temperature Conversion Time	(Note 9)	200	270	ms (max)
Quiescent Current	Serial Bus Inactive	300	550	µA (max)

Logic Electrical Characteristics

DIGITAL DC CHARACTERISTICS Unless otherwise noted, these specifications apply for V⁺ = 2.65V to 3.6V (Note 6). **Boldface limits apply for T_A = T_J = T_{MIN} to T_{MAX}**; all other limits T_A = T_J = +25°C, unless otherwise noted.

Symbol	Parameter	Conditions	Typical (Note 7)	Limits (Note 8)	Units (Limit)
V _{IN(1)}	Logical "1" Input Voltage			V⁺ x 0.7 V⁺ + 0.3	V (min) V (max)
V _{IN(0)}	Logical "0" Input Voltage			-0.3 V⁺ x 0.3	V (min) V (max)
	Input Hysteresis Voltage	V ⁺ = 3.0V to 3.6V	0.4	0.33	V (min)
I _{IN(1)}	Logical "1" Input Current	V _{IN} = V ⁺	0.005	3.0	µA (max)
I _{IN(0)}	Logical "0" Input Current	V _{IN} = 0V	-0.005	-3.0	µA (min)
C _{IN}	All Digital Inputs		20		pF
V _{OH}	High Level Output Voltage	I _{OH} = -400 µA		2.4	V (min)
V _{OL}	Low Level Output Voltage	I _{OL} = +2 mA		0.4	V (max)
I _{O_TRI-STATE}	TRI-STATE [®] Output Leakage Current	V _O = GND V _O = V ⁺		-1 +1	µA (min) µA (max)

Logic Electrical Characteristics (Continued)

SERIAL BUS DIGITAL SWITCHING CHARACTERISTICS Unless otherwise noted, these specifications apply for $V^+ = 2.65V$ to $3.6V$ (Note 6); C_L (load capacitance) on output lines = 100 pF unless otherwise specified. **Boldface limits apply for $T_A = T_J = T_{MIN}$ to T_{MAX}** ; all other limits $T_A = T_J = +25^\circ C$, unless otherwise noted.

Symbol	Parameter	Conditions	Typical (Note 7)	Limits (Note 8)	Units (Limit)
t_1	SC (Clock) Period			0.16 DC	μs (min) (max)
t_2	\overline{CS} Low to SC (Clock) High Set-Up Time			100	ns (min)
t_3	\overline{CS} Low to Data Out (SO) Delay			70	ns (max)
t_4	SC (Clock) Low to Data Out (SO) Delay			70	ns (max)
t_5	\overline{CS} High to Data Out (SO) TRI-STATE			200	ns (max)
t_6	SC (Clock) High to Data In (SI) Hold Time			50	ns (min)
t_7	Data In (SI) Set-Up Time to SC (Clock) High			30	ns (min)

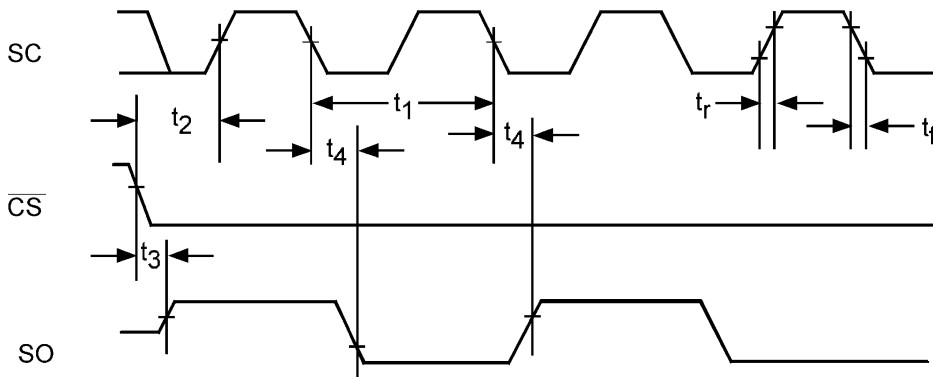

20031704

FIGURE 2. Data Output Timing Diagram

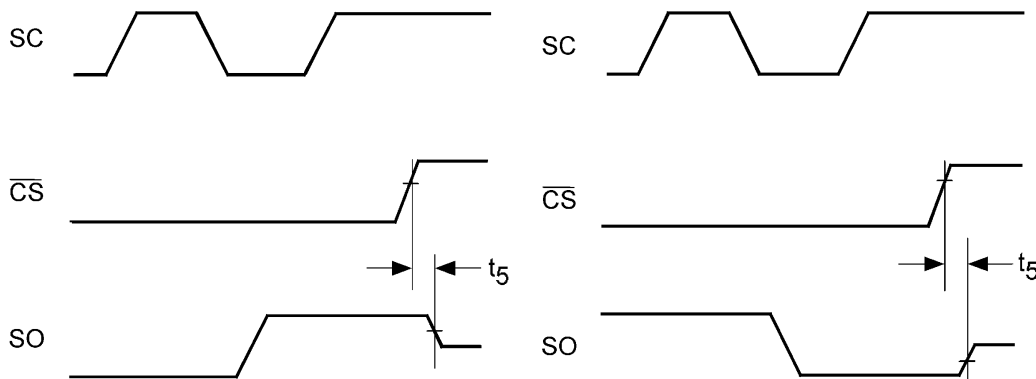

20031705

FIGURE 3. TRI-STATE Data Output Timing Diagram

Logic Electrical Characteristics (Continued)

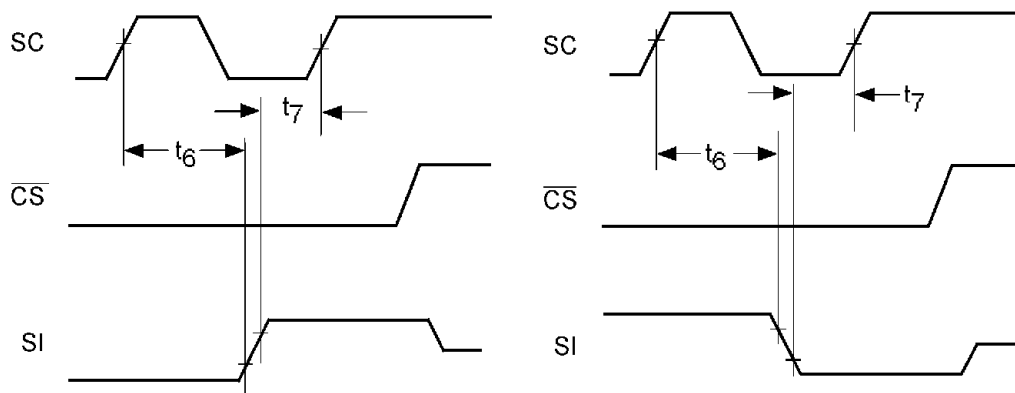

20031706

FIGURE 4. Data Input Timing Diagram

Note 1: Absolute Maximum Ratings indicate limits beyond which damage to the device may occur. DC and AC electrical specifications do not apply when operating the device beyond its rated operating conditions.

Note 2: When the input voltage (V_I) at any pin exceeds the power supplies ($V_I < \text{GND}$ or $V_I > +V_S$) the current at that pin should be limited to 5 mA.

Note 3: See AN-450 "Surface Mounting Methods and Their Effect on Product Reliability" or the section titled "Surface Mount" found in a current National Semiconductor Linear Data Book for other methods of soldering surface mount devices.

Note 4: Human body model, 100 pF discharged through a 1.5 k Ω resistor. Machine model, 200 pF discharged directly into each pin.

Note 5: The life expectancy of the LM71 will be reduced when operating at elevated temperatures. LM71 θ_{JA} (thermal resistance, junction-to-ambient) when attached to a printed circuit board with 2 oz. foil is summarized in the table below:

Device Number	NS Package Number	Thermal Resistance (θ_{JA})
LM71CIMF	MF05A	250°C/W
LM71CISD	SDE06A	57.6°C/W

Note 6: The LM71 will operate properly over the V^+ supply voltage range of 2.65V to 5.5V.

Note 7: Typicals are at $T_A = 25^\circ\text{C}$ and represent most likely parametric norm.

Note 8: Limits are guaranteed to National's AOQL (Average Outgoing Quality Level).

Note 9: This specification is provided only to indicate how often temperature data is updated. The LM71 can be read at any time without regard to conversion state (and will yield last conversion result). A conversion in progress will not be interrupted. The output shift register will be updated at the completion of the read and a new conversion restarted.

Note 10: For best accuracy, minimize output loading. Higher sink currents can affect sensor accuracy with internal heating. This can cause an error of 0.64°C at full rated sink current and saturation voltage based on junction-to-ambient thermal resistance.

Electrical Characteristics

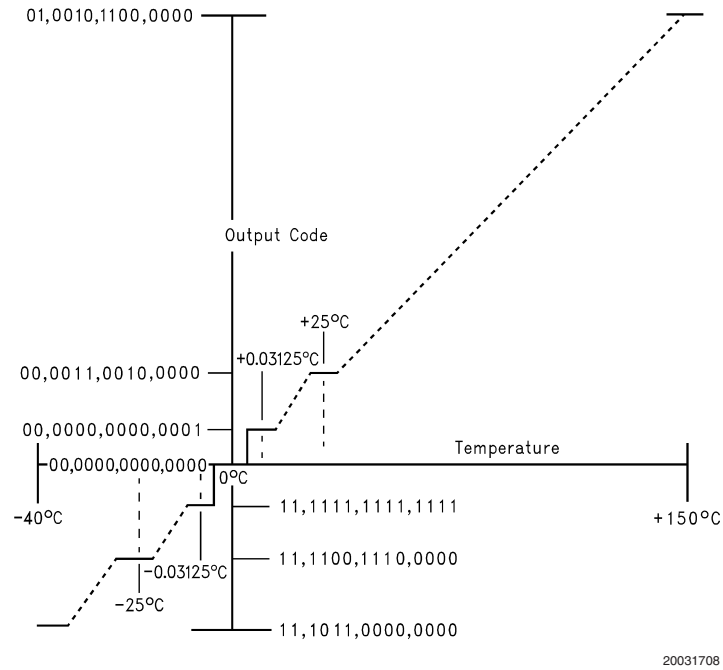

FIGURE 5. Temperature-to-Digital Transfer Function (Non-linear scale for clarity)

TRI-STATE Test Circuit

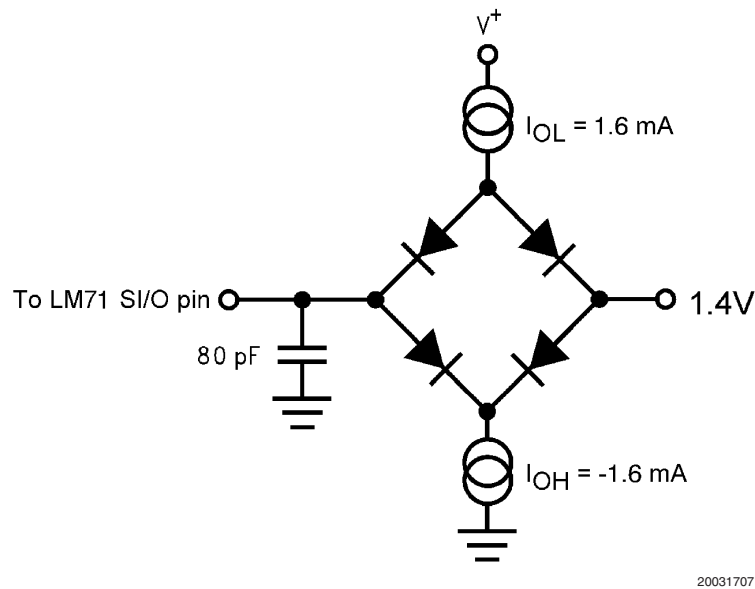
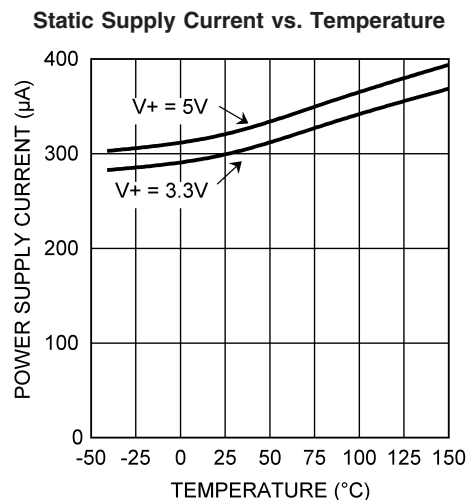
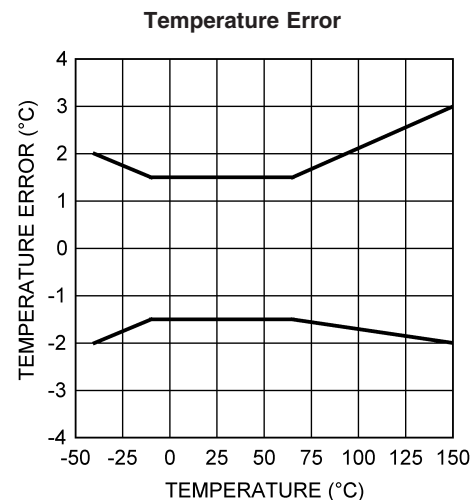

FIGURE 6.

Typical Performance Characteristics



20031796



20031797

1.0 Functional Description

The LM71 temperature sensor incorporates a temperature sensor and 13-bit plus sign $\Delta\Sigma$ ADC (Delta-Sigma Analog-to-Digital Converter). Compatibility of the LM71's three wire serial interface with SPI and MICROWIRE allows simple communications with common microcontrollers and processors. Shutdown mode can be used to optimize current drain for different applications. A Manufacturer's/Device ID register identifies the LM71 as National Semiconductor product.

1.1 POWER UP AND POWER DOWN

The LM71 always powers up in a known state. The power up default condition is continuous conversion mode. Immediately after power up the LM71 will output an erroneous code until the first temperature conversion has completed.

When the supply voltage is less than about 1.6V (typical), the LM71 is considered powered down. As the supply voltage rises above the nominal 1.6V power up threshold, the internal registers are reset to the power up default state described above.

1.2 SERIAL BUS INTERFACE

The LM71 operates as a slave and is compatible with SPI or MICROWIRE bus specifications. Data is clocked out on the falling edge of the serial clock (SC), while data is clocked in on the rising edge of SC. A complete transmit/receive communication will consist of 32 serial clocks. The first 16 clocks comprise the transmit phase of communication, while the second 16 clocks are the receive phase.

When \overline{CS} is high SI/O will be in TRI-STATE. Communication should be initiated by taking chip select (\overline{CS}) low. This should not be done when SC is changing from a low to high state. Once \overline{CS} is low the serial I/O pin (SI/O) will transmit the first bit of data. The master can then read this bit with the rising edge of SC. The remainder of the data will be clocked out by the falling edge of SC. \overline{CS} can be taken high at any

time during the transmit phase. If \overline{CS} is brought low in the middle of a conversion the LM71 will complete the conversion and the output shift register will be updated after \overline{CS} is brought back high.

The receive phase of a communication starts after 16 SC periods. \overline{CS} can remain low for 32 SC cycles. The LM71 will read the data available on the SI/O line on the rising edge of the serial clock. Input data is to an 8-bit shift register. The part will detect the last eight bits shifted into the register. The receive phase can last up to 16 SC periods. All ones must be shifted in order to place the part into shutdown. All zeros must be shifted in order to place the LM71 into continuous conversion mode. Only the following codes should be transmitted to the LM71:

- 00 hex for continuous conversion
- FF hex for shutdown

Another code may place the part into a test mode. Test modes are used by National Semiconductor to thoroughly test the function of the LM71 during production testing. Only eight bits have been defined above since only the last eight transmitted are detected by the LM71, before \overline{CS} is taken HIGH.

The following communication can be used to determine the Manufacturer's/Device ID and then immediately place the part into continuous conversion mode. With \overline{CS} continuously low:

- Read 16 bits of temperature data
- Write 16 bits of data commanding shutdown
- Read 16 bits of Manufacturer's/Device ID data
- Write 8 to 16 bits of data commanding Conversion Mode
- Take \overline{CS} HIGH.

Note that 300 ms will have to pass for a conversion to complete before the LM71 actually transmits temperature data.

1.0 Functional Description (Continued)

1.3 TEMPERATURE DATA FORMAT

Temperature data is represented by a 14-bit, two's complement word with an LSB (Least Significant Bit) equal to 0.03125°C:

Temperature	Digital Output	
	Binary	Hex
+150°C	0100 1011 0000 0011	4B03
+125°C	0011 1110 1000 0011	3E83
+25°C	0000 1100 1000 0011	0C83
+0.03125°C	0000 0000 0000 0111	0007
0°C	0000 0000 0000 0011	0003
-0.03125°C	1111 1111 1111 1111	FFFF
-25°C	1111 0011 1000 0011	F383
-40°C	1110 1100 0000 0011	EC03

The first data byte is the most significant byte with most significant bit first, permitting only as much data as neces-

1.5.1 Configuration Register

(Selects shutdown or continuous conversion modes):

(Write Only):

D15	D14	D13	D12	D11	D10	D9	D8	D7	D6	D5	D4	D3	D2	D1	D0
X	X	X	X	X	X	X	X	Shutdown							

D0–D15 set to XX FF hex enables shutdown mode.

D0–D15 set to 00 00 hex sets Continuous conversion mode.

Note: setting D0-D15 to any other values may place the LM70 into a manufacturer's test mode, upon which the LM71 will stop responding as described. These test modes are to be used for National Semiconductor production testing only. See Section 1.2 Serial Bus Interface for a complete discussion.

1.5.2 Temperature Register

(Read Only):

D15	D14	D13	D12	D11	D10	D9	D8	D7	D6	D5	D4	D3	D2	D1	D0
MSB	Bit 12	Bit 11	Bit 10	Bit 9	Bit 8	Bit 7	Bit 6	Bit 5	Bit 4	Bit 3	Bit 2	Bit1	LSB	1	1

D0–D1: Logic 1 will be output on SI/0.

D2–D15: Temperature Data. One LSB = 0.03125°C. Two's complement format.

1.5.3 Manufacturer/Device ID Register

(Read Only):

D15	D14	D13	D12	D11	D10	D9	D8	D7	D6	D5	D4	D3	D2	D1	D0
1	0	0	0	0	0	0	0	0	0	0	0	1	1	1	1

D0–D1: Logic 1 will be output on SI/0.

D2–D15: Manufacturer's/Device ID Data. This register is accessed whenever the LM71 is in shutdown mode.

sary to be read to determine temperature condition. For instance, if the first four bits of the temperature data indicate an overtemperature condition, the host processor could immediately take action to remedy the excessive temperatures.

1.4 SHUTDOWN MODE/MANUFACTURER'S ID

Shutdown mode is enabled by writing XX FF to the LM71 as shown in *Figure 7c*. The serial bus is still active when the LM71 is in shutdown. When in shutdown mode the LM71 always will output 1000 0000 0000 1111. This is the manufacturer's/Device ID information. The first 5-bits of the field (1000 0XXX) are reserved for manufacturer's ID.

1.5 INTERNAL REGISTER STRUCTURE

The LM71 has three registers, the temperature register, the configuration register and the manufacturer's/device identification register. The temperature and manufacturer's/device identification registers are read only. The configuration register is write only.

2.0 Serial Bus Timing Diagrams

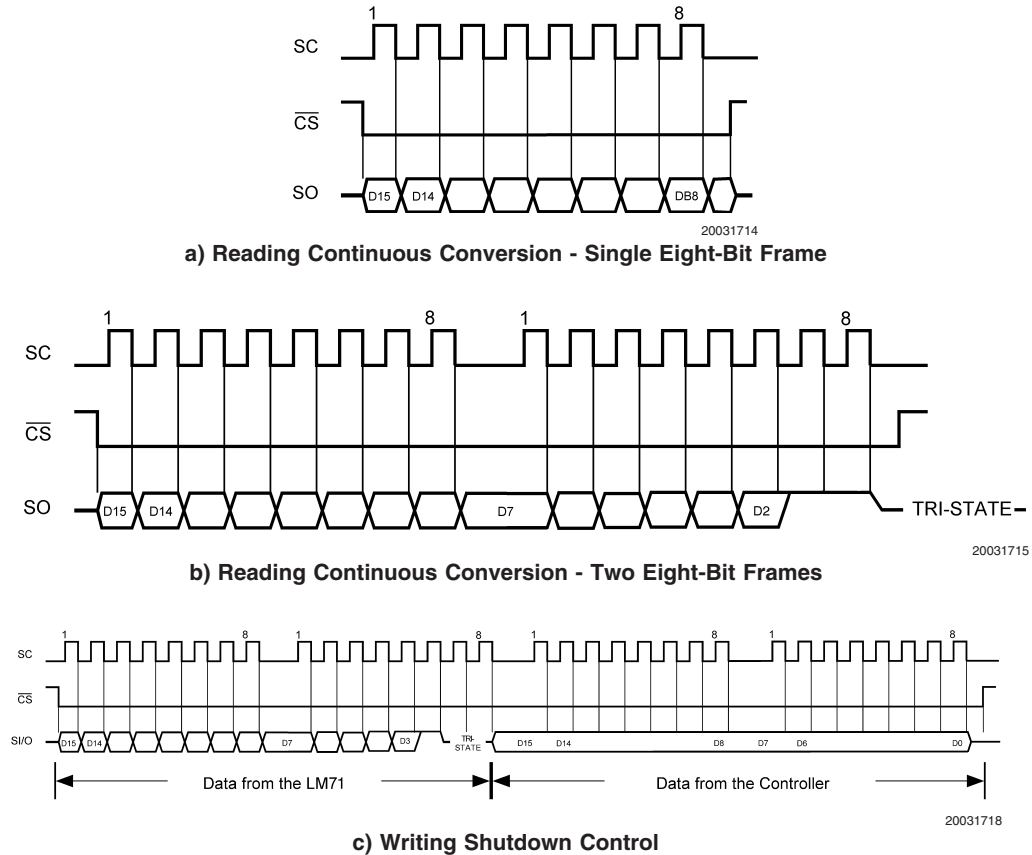

FIGURE 7. Timing Diagrams

3.0 Application Hints

To get the expected results when measuring temperature with an integrated circuit temperature sensor like the LM71, it is important to understand that the sensor measures its own die temperature. For the LM71, the best thermal path between the die and the outside world is through the LM71's pins. In the SOT23 package, all the pins on the LM71 will have an equal effect on the die temperature. Because the pins represent a good thermal path to the LM71 die, the LM71 will provide an accurate measurement of the temperature of the printed circuit board on which it is mounted. There is a less efficient thermal path between the plastic package and the LM71 die. If the ambient air temperature is signifi-

cantly different from the printed circuit board temperature, it will have a small effect on the measured temperature.

In probe-type applications, the LM71 can be mounted inside a sealed-end metal tube, and can then be dipped into a bath or screwed into a threaded hole in a tank. As with any IC, the LM71 and accompanying wiring and circuits must be kept insulated and dry, to avoid leakage and corrosion. This is especially true if the circuit may operate at cold temperatures where condensation can occur. Printed-circuit coatings and varnishes such as Humiseal and epoxy paints or dips are often used to insure that moisture cannot corrode the LM71 or its connections.

4.0 Typical Applications

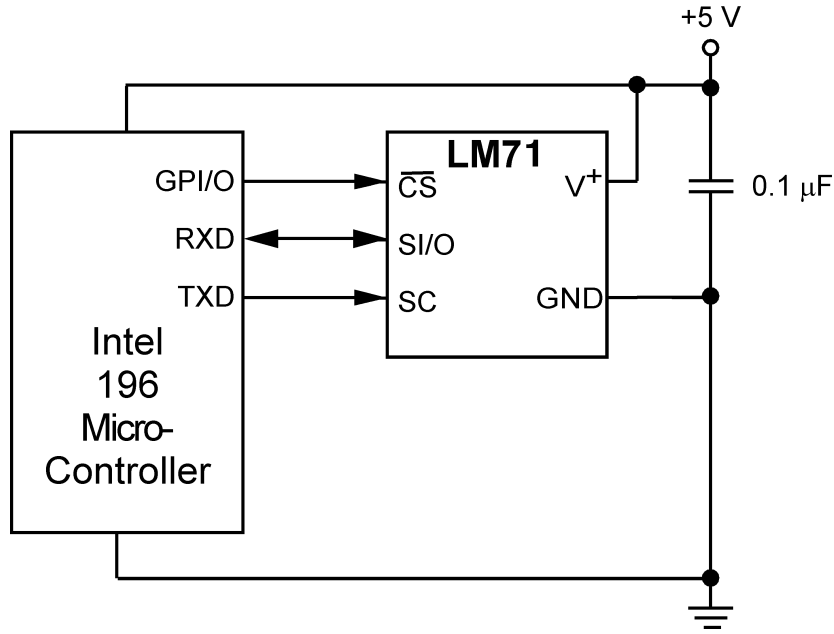

20031720

FIGURE 8. Temperature monitor using Intel 196 processor

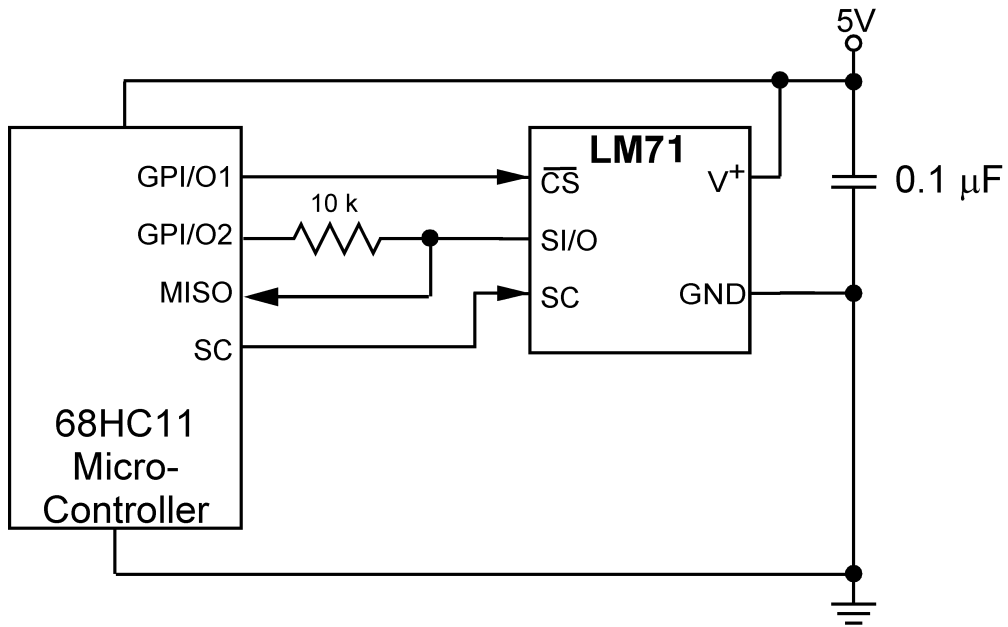

20031719

FIGURE 9. LM71 digital input control using micro-controller's general purpose I/O.

Physical Dimensions inches (millimeters) unless otherwise noted

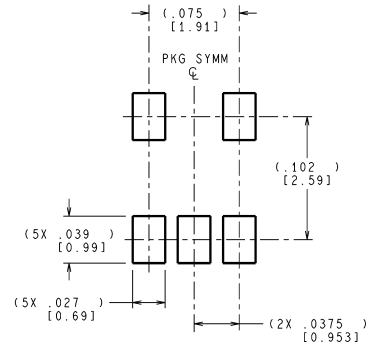
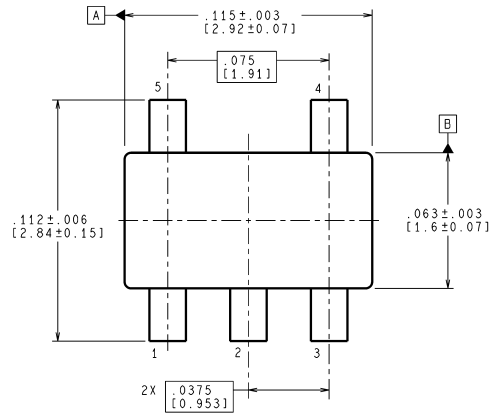

LAND PATTERN RECOMMENDATION

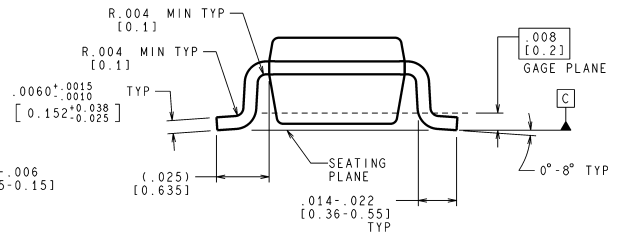
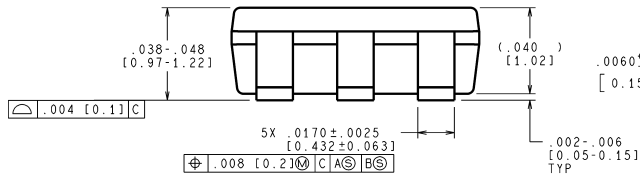

CONTROLLING DIMENSION IS INCH
 VALUES IN [] ARE MILLIMETERS

MF05A (Rev B)

Order Number LM71
Top View
CIMF
NS Package Number MF05A

Physical Dimensions inches (millimeters) unless otherwise noted (Continued)

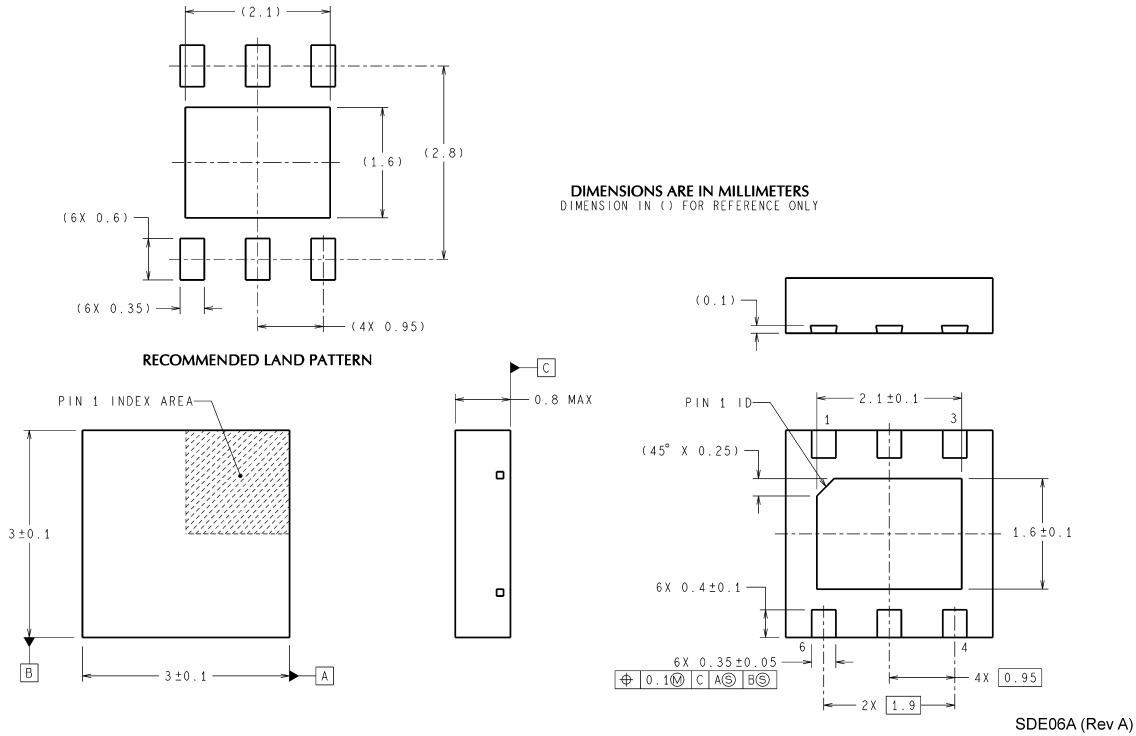

**Order Number LM71Bottom View
CISD
NS Package Number SDE06A**

National does not assume any responsibility for use of any circuitry described, no circuit patent licenses are implied and National reserves the right at any time without notice to change said circuitry and specifications.

For the most current product information visit us at www.national.com.

LIFE SUPPORT POLICY

NATIONAL'S PRODUCTS ARE NOT AUTHORIZED FOR USE AS CRITICAL COMPONENTS IN LIFE SUPPORT DEVICES OR SYSTEMS WITHOUT THE EXPRESS WRITTEN APPROVAL OF THE PRESIDENT AND GENERAL COUNSEL OF NATIONAL SEMICONDUCTOR CORPORATION. As used herein:

1. Life support devices or systems are devices or systems which, (a) are intended for surgical implant into the body, or (b) support or sustain life, and whose failure to perform when properly used in accordance with instructions for use provided in the labeling, can be reasonably expected to result in a significant injury to the user.
2. A critical component is any component of a life support device or system whose failure to perform can be reasonably expected to cause the failure of the life support device or system, or to affect its safety or effectiveness.

BANNED SUBSTANCE COMPLIANCE

National Semiconductor certifies that the products and packing materials meet the provisions of the Customer Products Stewardship Specification (CSP-9-111C2) and the Banned Substances and Materials of Interest Specification (CSP-9-111S2) and contain no "Banned Substances" as defined in CSP-9-111S2.



National Semiconductor
Americas Customer
Support Center
Email: new.feedback@nsc.com
Tel: 1-800-272-9959

National Semiconductor
Europe Customer Support Center
Fax: +49 (0) 180-530 85 86
Email: europe.support@nsc.com
Deutsch Tel: +49 (0) 69 9508 6208
English Tel: +44 (0) 870 24 0 2171
Français Tel: +33 (0) 1 41 91 8790

National Semiconductor
Asia Pacific Customer
Support Center
Email: ap.support@nsc.com

National Semiconductor
Japan Customer Support Center
Fax: 81-3-5639-7507
Email: jpn.feedback@nsc.com
Tel: 81-3-5639-7560