

# LM56

## Dual Output Low Power Thermostat

### General Description

The LM56 is a precision low power thermostat. Two stable temperature trip points ( $V_{T1}$  and  $V_{T2}$ ) are generated by dividing down the LM56 1.250V bandgap voltage reference using 3 external resistors. The LM56 has two digital outputs. OUT1 goes LOW when the temperature exceeds  $T1$  and goes HIGH when the temperature goes below  $(T1 - T_{HYST})$ . Similarly, OUT2 goes LOW when the temperature exceeds  $T2$  and goes HIGH when the temperature goes below  $(T2 - T_{HYST})$ .  $T_{HYST}$  is an internally set 5°C typical hysteresis.

The LM56 is available in an 8-lead Mini-SO8 surface mount package and an 8-lead small outline package.

### Applications

- Microprocessor Thermal Management
- Appliances
- Portable Battery Powered 3.0V or 5V Systems
- Fan Control
- Industrial Process Control
- HVAC Systems
- Remote Temperature Sensing
- Electronic System Protection

### Features

- Digital outputs support TTL logic levels
- Internal temperature sensor
- 2 internal comparators with hysteresis
- Internal voltage reference
- Available in 8-pin SO and Mini-SO8 plastic packages

### Key Specifications

- Power Supply Voltage 2.7V–10V
- Power Supply Current 230  $\mu$ A (max)
- $V_{REF}$  1.250V  $\pm$ 1% (max)
- Hysteresis Temperature 5°C
- Internal Temperature Sensor Output Voltage:  
(+6.20 mV/°C x T) + 395 mV
- Temperature Trip Point Accuracy:

	LM56BIM	LM56CIM
+25°C	$\pm 2^\circ\text{C}$ (max)	$\pm 3^\circ\text{C}$ (max)
+25°C to +85°C	$\pm 2^\circ\text{C}$ (max)	$\pm 3^\circ\text{C}$ (max)
-40°C to +125°C	$\pm 3^\circ\text{C}$ (max)	$\pm 4^\circ\text{C}$ (max)

### Simplified Block Diagram and Connection Diagram

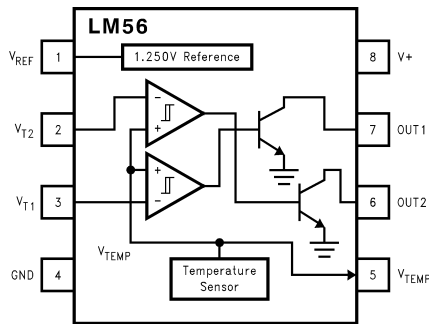

01289301

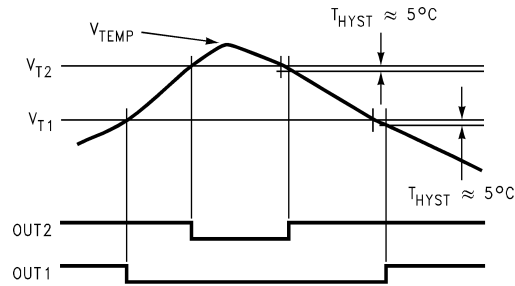

01289302

Order Number	LM56BIM	LM56BIMX	LM56CIM	LM56CIMX	LM56BIMM	LM56BIMMX	LM56CIMM	LM56CIMMX
NS Package	M08A	M08A	M08A	M08A	MUA08A	MUA08A	MUA08A	MUA08A
Number	SOP-8	SOP-8	SOP-8	SOP-8	MSOP-8	MSOP-8	MSOP-8	MSOP-8
Transport Media	Rail	2500 Units Tape & Reel	Rail	2500 Units Tape & Reel	1000 Units Tape & Reel	3500 Units Tape & Reel	1000 Units Tape & Reel	3500 Units Tape & Reel
Package Marking	LM56BIM	LM56BIM	LM56CIM	LM56CIM	T02B	T02B	T02C	T02C



**Absolute Maximum Ratings** (Note 1)

Input Voltage	12V
Input Current at any pin (Note 2)	5 mA
Package Input Current (Note 2)	20 mA
Package Dissipation at $T_A = 25^\circ\text{C}$ (Note 4)	900 mW
ESD Susceptibility (Note 5)	
Human Body Model - Pin 3 Only:	800V
All other pins	1000V
Machine Model	125V
Storage Temperature	$-65^\circ\text{C}$ to $+150^\circ\text{C}$

**Operating Ratings** (Note 1)

Operating Temperature Range	$T_{\text{MIN}} \leq T_A \leq T_{\text{MAX}}$
LM56BIM, LM56CIM	$-40^\circ\text{C} \leq T_A \leq +125^\circ\text{C}$
Positive Supply Voltage ( $V^+$ )	+2.7V to +10V
Maximum $V_{\text{OUT1}}$ and $V_{\text{OUT2}}$	+10V

Soldering process must comply with National Semiconductor's Reflow Temperature Profile specifications. Refer to [www.national.com/packaging](http://www.national.com/packaging). (Note 3)

**LM56 Electrical Characteristics**

The following specifications apply for  $V^+ = 2.7 V_{\text{DC}}$ , and  $V_{\text{REF}}$  load current = 50  $\mu\text{A}$  unless otherwise specified. **Boldface limits apply for  $T_A = T_J = T_{\text{MIN}}$  to  $T_{\text{MAX}}$** ; all other limits  $T_A = T_J = 25^\circ\text{C}$  unless otherwise specified.

Symbol	Parameter	Conditions	Typical (Note 6)	LM56BIM Limits (Note 7)	LM56CIM Limits (Note 7)	Units (Limits)
<b>Temperature Sensor</b>						
	Trip Point Accuracy (Includes $V_{\text{REF}}$ , Comparator Offset, and Temperature Sensitivity errors)	$+25^\circ\text{C} \leq T_A \leq +85^\circ\text{C}$		$\pm 2$	$\pm 3$	$^\circ\text{C}$ (max)
		$-40^\circ\text{C} \leq T_A \leq +125^\circ\text{C}$		$\pm 2$	$\pm 3$	$^\circ\text{C}$ (max)
				<b><math>\pm 3</math></b>	<b><math>\pm 4</math></b>	$^\circ\text{C}$ (max)
	Trip Point Hysteresis	$T_A = -40^\circ\text{C}$	4	3 6	3 6	$^\circ\text{C}$ (min) $^\circ\text{C}$ (max)
		$T_A = +25^\circ\text{C}$	5	3.5 6.5	3.5 6.5	$^\circ\text{C}$ (min) $^\circ\text{C}$ (max)
		$T_A = +85^\circ\text{C}$	6	4.5 7.5	4.5 7.5	$^\circ\text{C}$ (min) $^\circ\text{C}$ (max)
		$T_A = +125^\circ\text{C}$	6	4 8	4 8	$^\circ\text{C}$ (min) $^\circ\text{C}$ (max)
	Internal Temperature Sensitivity		+6.20			mV/ $^\circ\text{C}$
	Temperature Sensitivity Error			$\pm 2$	$\pm 3$	$^\circ\text{C}$ (max)
					<b><math>\pm 3</math></b>	<b><math>\pm 4</math></b>
	Output Impedance	$-1 \mu\text{A} \leq I_L \leq +40 \mu\text{A}$		<b>1500</b>	<b>1500</b>	$\Omega$ (max)
	Line Regulation	$+3.0\text{V} \leq V^+ \leq +10\text{V}$ , $+25^\circ\text{C} \leq T_A \leq +85^\circ\text{C}$		$\pm 0.36$	$\pm 0.36$	mV/V (max)
		$+3.0\text{V} \leq V^+ \leq +10\text{V}$ , $-40^\circ\text{C} \leq T_A < 25^\circ\text{C}$		$\pm 0.61$	$\pm 0.61$	mV/V (max)
		$+2.7\text{V} \leq V^+ \leq +3.3\text{V}$			<b><math>\pm 2.3</math></b>	<b><math>\pm 2.3</math></b>
<b><math>V_{\text{T1}}</math> and <math>V_{\text{T2}}</math> Analog Inputs</b>						
$I_{\text{BIAS}}$	Analog Input Bias Current		150	<b>300</b>	<b>300</b>	nA (max)
$V_{\text{IN}}$	Analog Input Voltage Range		$V^+ - 1$ GND			V V
$V_{\text{OS}}$	Comparator Offset		2	<b>8</b>	<b>8</b>	mV (max)
<b><math>V_{\text{REF}}</math> Output</b>						
$V_{\text{REF}}$	$V_{\text{REF}}$ Nominal		1.250V			V
	$V_{\text{REF}}$ Error			$\pm 1$	$\pm 1$	% (max)
					<b><math>\pm 12.5</math></b>	<b><math>\pm 12.5</math></b>
$\Delta V_{\text{REF}}/\Delta V^+$	Line Regulation	$+3.0\text{V} \leq V^+ \leq +10\text{V}$	0.13	<b>0.25</b>	<b>0.25</b>	mV/V (max)
		$+2.7\text{V} \leq V^+ \leq +3.3\text{V}$	0.15	<b>1.1</b>	<b>1.1</b>	mV (max)
$\Delta V_{\text{REF}}/\Delta I_L$	Load Regulation Sourcing	$+30 \mu\text{A} \leq I_L \leq +50 \mu\text{A}$		<b>0.15</b>	<b>0.15</b>	mV/ $\mu\text{A}$ (max)

Symbol	Parameter	Conditions	Typical (Note 6)	Limits (Note 7)	Units (Limits)
<b>V<sup>+</sup> Power Supply</b>					
I <sub>S</sub>	Supply Current	V <sup>+</sup> = +10V		<b>230</b>	μA (max)
		V <sup>+</sup> = +2.7V		<b>230</b>	μA (max)
<b>Digital Outputs</b>					
I <sub>OUT("1")</sub>	Logical "1" Output Leakage Current	V <sup>+</sup> = +5.0V		<b>1</b>	μA (max)
V <sub>OUT("0")</sub>	Logical "0" Output Voltage	I <sub>OUT</sub> = +50 μA		<b>0.4</b>	V (max)

**Note 1:** Absolute Maximum Ratings indicate limits beyond which damage to the device may occur. Operating Ratings indicate conditions for which the device is functional, but do not guarantee specific performance limits. For guaranteed specifications and test conditions, see the Electrical Characteristics. The guaranteed specifications apply only for the test conditions listed. Some performance characteristics may degrade when the device is not operated under the listed test conditions.

**Note 2:** When the input voltage (V<sub>I</sub>) at any pin exceeds the power supply (V<sub>I</sub> < GND or V<sub>I</sub> > V<sup>+</sup>), the current at that pin should be limited to 5 mA. The 20 mA maximum package input current rating limits the number of pins that can safely exceed the power supplies with an input current of 5 mA to four.

**Note 3:** Reflow temperature profiles are different for lead-free and non-lead-free packages.

**Note 4:** The maximum power dissipation must be derated at elevated temperatures and is dictated by T<sub>Jmax</sub> (maximum junction temperature), θ<sub>JA</sub> (junction to ambient thermal resistance) and T<sub>A</sub> (ambient temperature). The maximum allowable power dissipation at any temperature is P<sub>D</sub> = (T<sub>Jmax</sub> - T<sub>A</sub>) / θ<sub>JA</sub> or the number given in the Absolute Maximum Ratings, whichever is lower. For this device, T<sub>Jmax</sub> = 125°C. For this device the typical thermal resistance (θ<sub>JA</sub>) of the different package types when board mounted follow:

Package Type	θ <sub>JA</sub>
M08A	110°C/W
MUA08A	250°C/W

**Note 5:** The human body model is a 100 pF capacitor discharge through a 1.5 kΩ resistor into each pin. The machine model is a 200 pF capacitor discharged directly into each pin.

**Note 6:** Typicals are at T<sub>J</sub> = T<sub>A</sub> = 25°C and represent most likely parametric norm.

**Note 7:** Limits are guaranteed to National's AOQL (Average Outgoing Quality Level).

# Typical Performance Characteristics

**Quiescent Current vs Temperature**

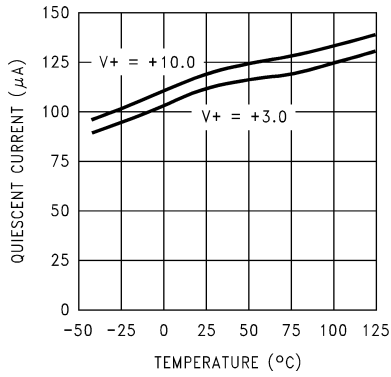

01289304

**V<sub>REF</sub> Output Voltage vs Load Current**

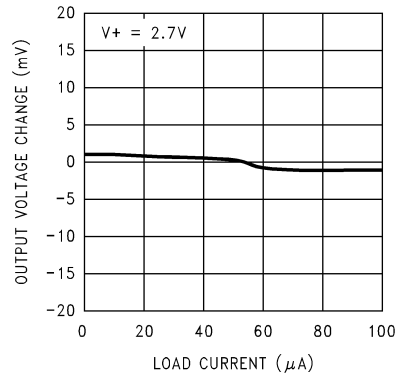

01289305

**OUT1 and OUT2 Voltage Levels vs Load Current**

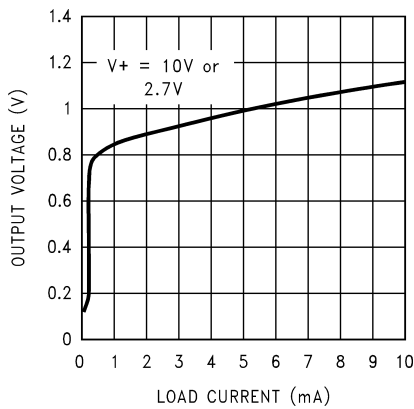

01289332

**Trip Point Hysteresis vs Temperature**

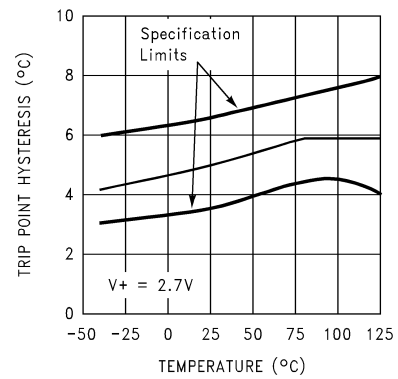

01289307

**Temperature Sensor Output Voltage vs Temperature**

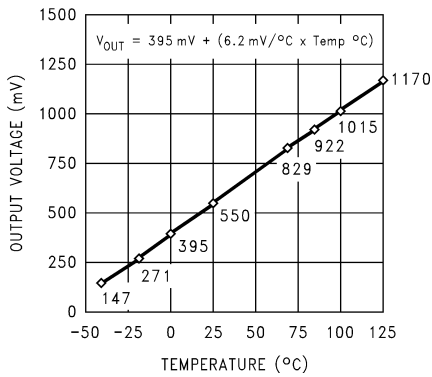

01289308

**Temperature Sensor Output Accuracy vs Temperature**

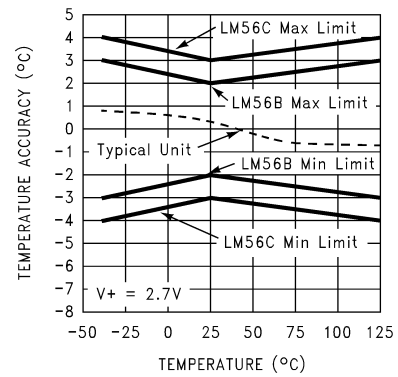

01289309

# Typical Performance Characteristics (Continued)

**Trip Point Accuracy vs Temperature**

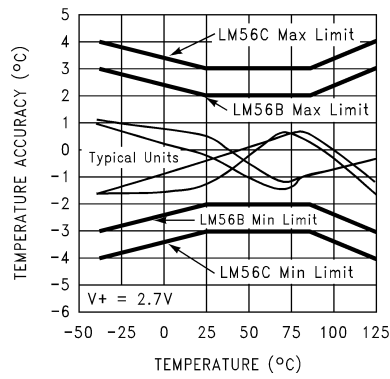

**Comparator Bias Current vs Temperature**

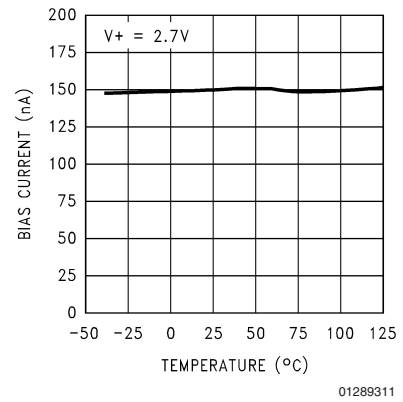

**OUT1 and OUT2 Leakage Current vs Temperature**

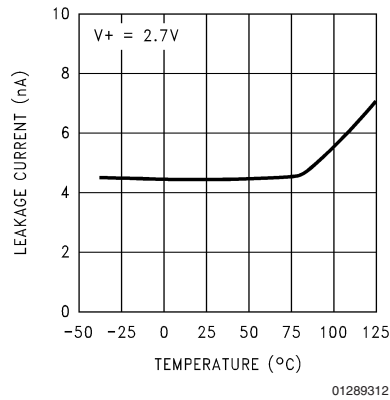

**V<sub>TEMP</sub> Output Line Regulation vs Temperature**

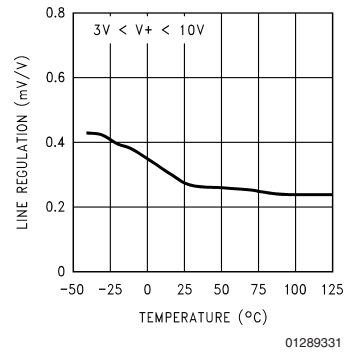

**V<sub>REF</sub> Start-Up Response**

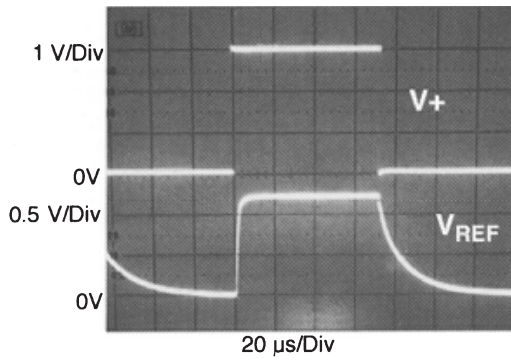

**V<sub>TEMP</sub> Start-Up Response**

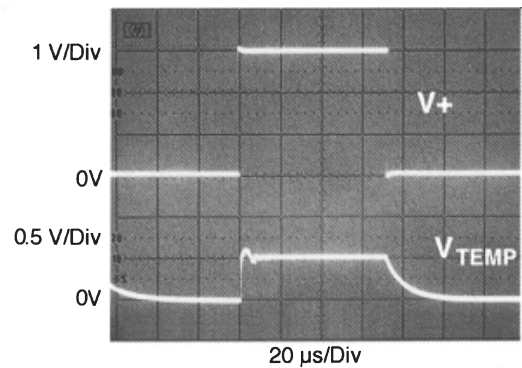

## Functional Description

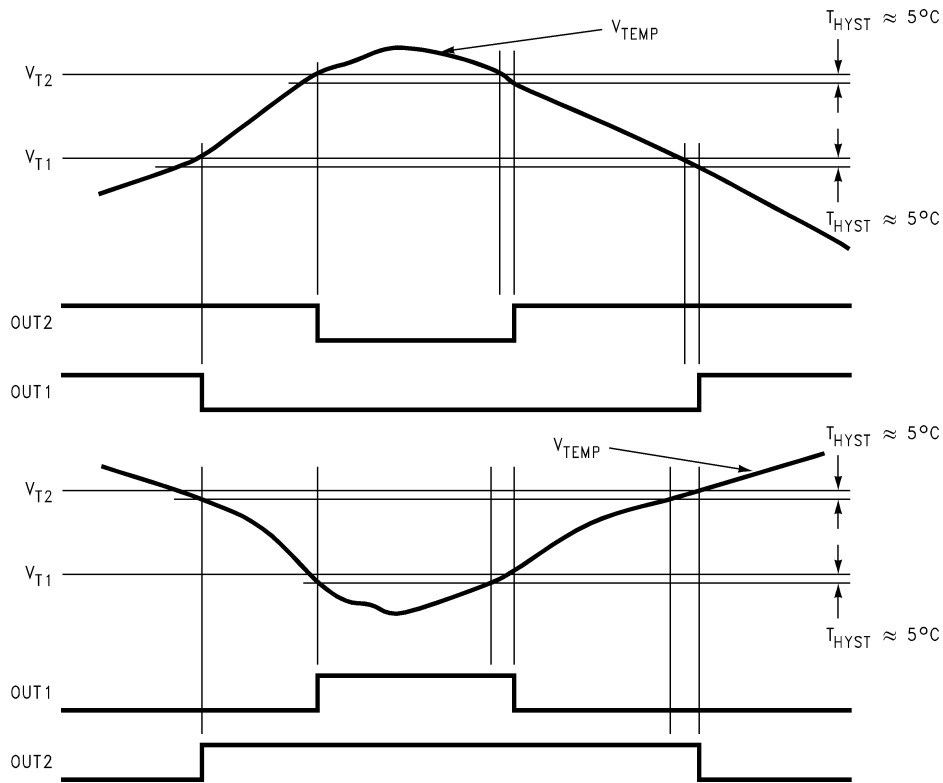

01289315

## Pin Descriptions

- V<sup>+</sup>** This is the positive supply voltage pin. This pin should be bypassed with a 0.1  $\mu\text{F}$  capacitor to ground.
- GND** This is the ground pin.
- V<sub>REF</sub>** This is the 1.250V bandgap voltage reference output pin. In order to maintain trip point accuracy this pin should source a 50  $\mu\text{A}$  load.
- V<sub>TEMP</sub>** This is the temperature sensor output pin.
- OUT1** This is an open collector digital output. OUT1 is active LOW. It goes LOW when the temperature is greater than  $T_1$  and goes HIGH when the temperature drops below  $T_1 - 5^\circ\text{C}$ . This output is not intended to directly drive a fan motor.
- OUT2** This is an open collector digital output. OUT2 is active LOW. It goes LOW when the temperature is greater than the  $T_2$  set point and goes HIGH when the temperature is less than  $T_2 - 5^\circ\text{C}$ . This output is not intended to directly drive a fan motor.
- V<sub>T1</sub>** This is the input pin for the temperature trip point voltage for OUT1.
- V<sub>T2</sub>** This is the input pin for the low temperature trip point voltage for OUT2.

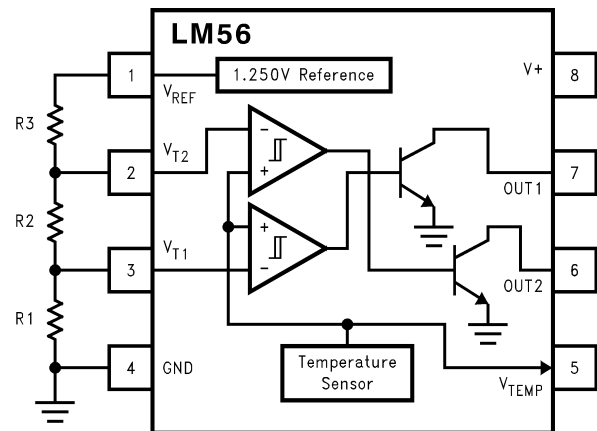

01289316

$$V_{T1} = 1.250\text{V} \times (R1)/(R1 + R2 + R3)$$

$$V_{T2} = 1.250\text{V} \times (R1 + R2)/(R1 + R2 + R3)$$

where:

$$(R1 + R2 + R3) = 27 \text{ k}\Omega \text{ and}$$

$$V_{T1} \text{ or } T2 = [6.20 \text{ mV}/^\circ\text{C} \times T] + 395 \text{ mV} \text{ therefore:}$$

$$R1 = V_{T1}/(1.25\text{V}) \times 27 \text{ k}\Omega$$

$$R2 = (V_{T2}/(1.25\text{V}) \times 27 \text{ k}\Omega) - R1$$

$$R3 = 27 \text{ k}\Omega - R1 - R2$$

## Application Hints

### 1.0 LM56 TRIP POINT ACCURACY SPECIFICATION

For simplicity the following is an analysis of the trip point accuracy using the single output configuration show in *Figure 2* with a set point of 82°C.

Trip Point Error Voltage =  $V_{TPE}$ ,

Comparator Offset Error for  $V_{T1E}$

Temperature Sensor Error =  $V_{TSE}$

Reference Output Error =  $V_{RE}$

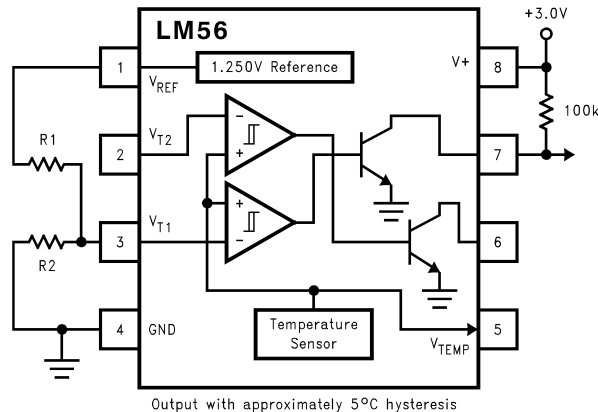

01289317

**FIGURE 2. Single Output Configuration**

$$1. V_{TPE} = \pm V_{T1E} - V_{TSE} + V_{RE}$$

Where:

$$2. V_{T1E} = \pm 8 \text{ mV (max)}$$

$$3. V_{TSE} = (6.20 \text{ mV/}^\circ\text{C}) \times (\pm 3^\circ\text{C}) = \pm 18.6 \text{ mV}$$

$$4. V_{RE} = 1.250\text{V} \times (\pm 0.01) R2/(R1 + R2)$$

Using Equations from page 1 of the datasheet.

$$V_{T1} = 1.25\text{V} \times R2/(R1 + R2) = (6.20 \text{ mV/}^\circ\text{C})(82^\circ\text{C}) + 395 \text{ mV}$$

$$\text{Solving for } R2/(R1 + R2) = 0.7227$$

then,

$$5. V_{RE} = 1.250\text{V} \times (\pm 0.01) R2/(R1 + R2) = (0.0125) \times (0.7227) = \pm 9.03 \text{ mV}$$

The individual errors do not add algebraically because, the odds of all the errors being at their extremes are rare. This is proven by the fact the specification for the trip point accuracy stated in the Electrical Characteristic for the temperature range of  $-40^\circ\text{C}$  to  $+125^\circ\text{C}$ , for example, is specified at  $\pm 3^\circ\text{C}$  for the LM56BIM. Note this trip point error specification does

not include any error introduced by the tolerance of the actual resistors used, nor any error introduced by power supply variation.

If the resistors have a  $\pm 0.5\%$  tolerance, an additional error of  $\pm 0.4^\circ\text{C}$  will be introduced. This error will increase to  $\pm 0.8^\circ\text{C}$  when both external resistors have a  $\pm 1\%$  tolerance.

### 2.0 BIAS CURRENT EFFECT ON TRIP POINT ACCURACY

Bias current for the comparator inputs is 300 nA (max) each, over the specified temperature range and will not introduce considerable error if the sum of the resistor values are kept to about 27 k $\Omega$  as shown in the typical application of *Figure 1*. This bias current of one comparator input will not flow if the temperature is well below the trip point level. As the temperature approaches trip point level the bias current will start to flow into the resistor network. When the temperature sensor output is equal to the trip point level the bias current will be 150 nA (max). Once the temperature is well above the trip point level the bias current will be 300 nA (max). Therefore, the first trip point will be affected by 150 nA of bias current. The leakage current is very small when the comparator input transistor of the different pair is off (see *Figure 3*).

The effect of the bias current on the first trip point can be defined by the following equations:

$$K1 = \frac{R1}{R1 + R2 + R3}$$

$$V_{T1} = K1 \times V_{REF} + K1 \times (R2 + R3) \times \frac{I_B}{2}$$

where  $I_B = 300 \text{ nA}$  (the maximum specified error).

The effect of the bias current on the second trip point can be defined by the following equations:

$$K2 = \frac{R1 + R2}{R1 + R2 + R3}$$

$$V_{T2} = K2 \times V_{REF} + \left( K1 + \frac{K2}{2} \right) \times R3 \times I_B$$

where  $I_B = 300 \text{ nA}$  (the maximum specified error).

The closer the two trip points are to each other the more significant the error is. Worst case would be when  $V_{T1} = V_{T2} = V_{REF}/2$ .



## Application Hints (Continued)

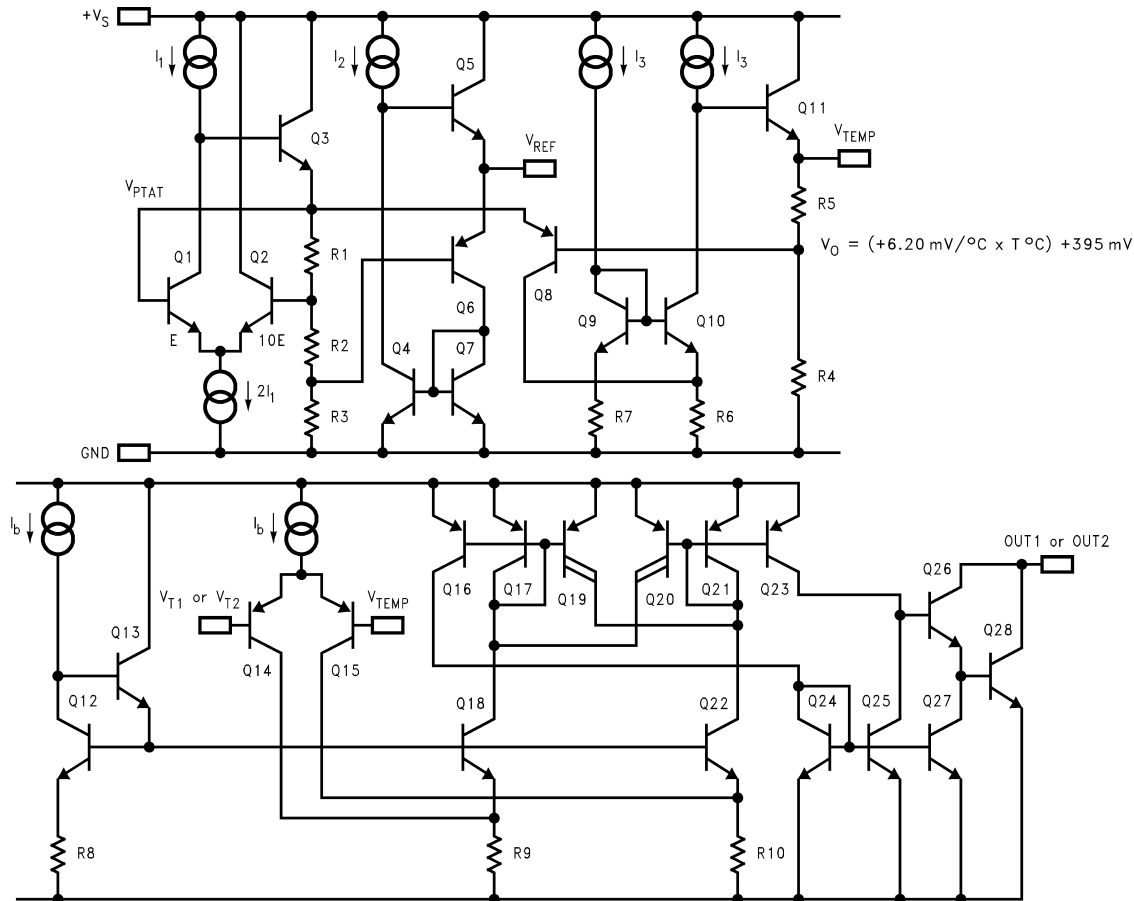

01289318

FIGURE 3. Simplified Schematic

### 3.0 MOUNTING CONSIDERATIONS

The majority of the temperature that the LM56 is measuring is the temperature of its leads. Therefore, when the LM56 is placed on a printed circuit board, it is not sensing the temperature of the ambient air. It is actually sensing the temperature difference of the air and the lands and printed circuit board that the leads are attached to. The most accurate temperature sensing is obtained when the ambient temperature is equivalent to the LM56's lead temperature.

As with any IC, the LM56 and accompanying wiring and circuits must be kept insulated and dry, to avoid leakage and corrosion. This is especially true if the circuit operates at cold temperatures where condensation can occur. Printed-circuit coatings are often used to ensure that moisture cannot corrode the LM56 or its connections.

## Application Hints (Continued)

### 4.0 $V_{REF}$ AND $V_{TEMP}$ CAPACITIVE LOADING

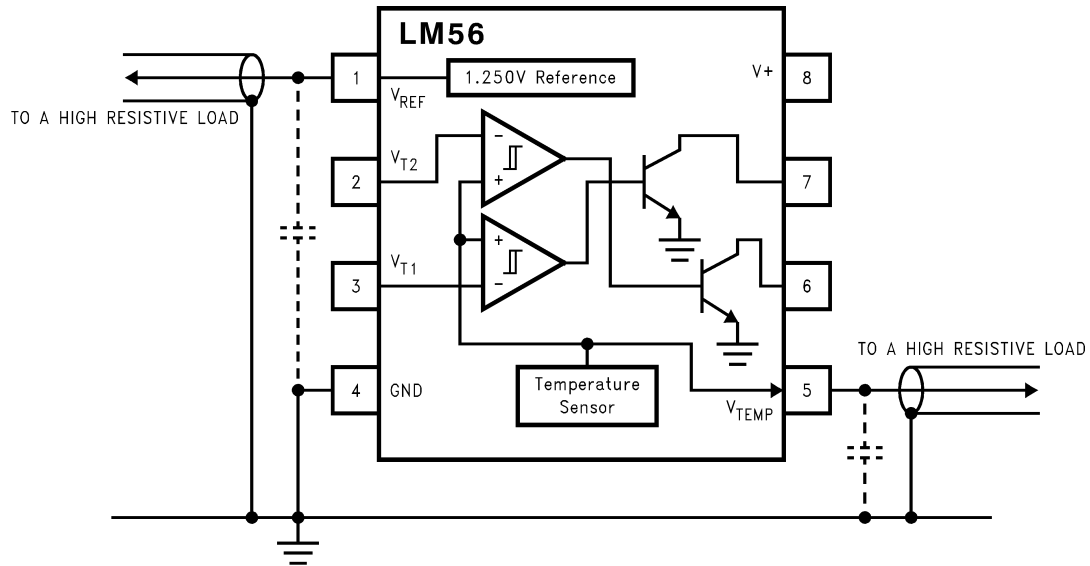

01289319

FIGURE 4. Loading of  $V_{REF}$  and  $V_{TEMP}$

The LM56  $V_{REF}$  and  $V_{TEMP}$  outputs handle capacitive loading well. Without any special precautions, these outputs can drive any capacitive load as shown in *Figure 4*.

### 5.0 NOISY ENVIRONMENTS

Over the specified temperature range the LM56  $V_{TEMP}$  output has a maximum output impedance of  $1500\Omega$ . In an extremely noisy environment it may be necessary to add some filtering to minimize noise pickup. It is recommended that  $0.1\ \mu\text{F}$  be added from  $V^+$  to GND to bypass the power supply voltage, as shown in *Figure 4*. In a noisy environment it may be necessary to add a capacitor from the  $V_{TEMP}$  output to ground. A  $1\ \mu\text{F}$  output capacitor with the  $1500\Omega$  output impedance will form a 106 Hz lowpass filter. Since the thermal time constant of the  $V_{TEMP}$  output is much slower than the 9.4 ms time constant formed by the RC, the overall response time of the  $V_{TEMP}$  output will not be significantly affected. For much larger capacitors this additional time lag will increase the overall response time of the LM56.

### 6.0 APPLICATIONS CIRCUITS

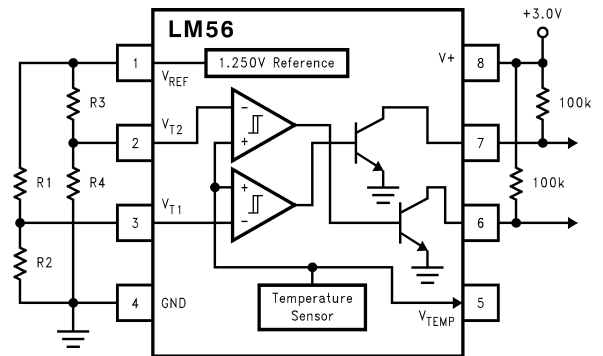

01289320

FIGURE 5. Reducing Errors Caused by Bias Current

The circuit shown in *Figure 5* will reduce the effective bias current error for  $V_{T2}$  as discussed in Section 3.0 to be equivalent to the error term of  $V_{T1}$ . For this circuit the effect of the bias current on the first trip point can be defined by the following equations:

$$K1 = \frac{R2}{R1 + R2}$$

$$V_{T1} = K1 \times V_{REF} + K1 \times (R1) \times \frac{I_B}{2}$$

where  $I_B = 300\ \text{nA}$  (the maximum specified error).

Similarly, bias current affect on  $V_{T2}$  can be defined by:

### Application Hints (Continued)

$$K2 = \frac{R4}{R3 + R4}$$

$$V_{T1} = K2 \times V_{REF} + K1 \times (R3) \times \frac{I_B}{2}$$

where  $I_B = 300 \text{ nA}$  (the maximum specified error).

The current shown in *Figure 6* is a simple overtemperature detector for power devices. In this example, an audio power amplifier IC is bolted to a heat sink and an LM56 Celsius temperature sensor is mounted on a PC board that is bolted to the heat sink near the power amplifier. To ensure that the

sensing element is at the same temperature as the heat sink, the sensor's leads are mounted to pads that have feed throughs to the back side of the PC board. Since the LM56 is sensing the temperature of the actual PC board the back side of the PC board also has large ground plane to help conduct the heat to the device. The comparator's output goes low if the heat sink temperature rises above a threshold set by R1, R2, and the voltage reference. This fault detection output from the comparator now can be used to turn on a cooling fan. The circuit as shown in design to turn the fan on when heat sink temperature exceeds about 80°C, and to turn the fan off when the heat sink temperature falls below approximately 75°C.

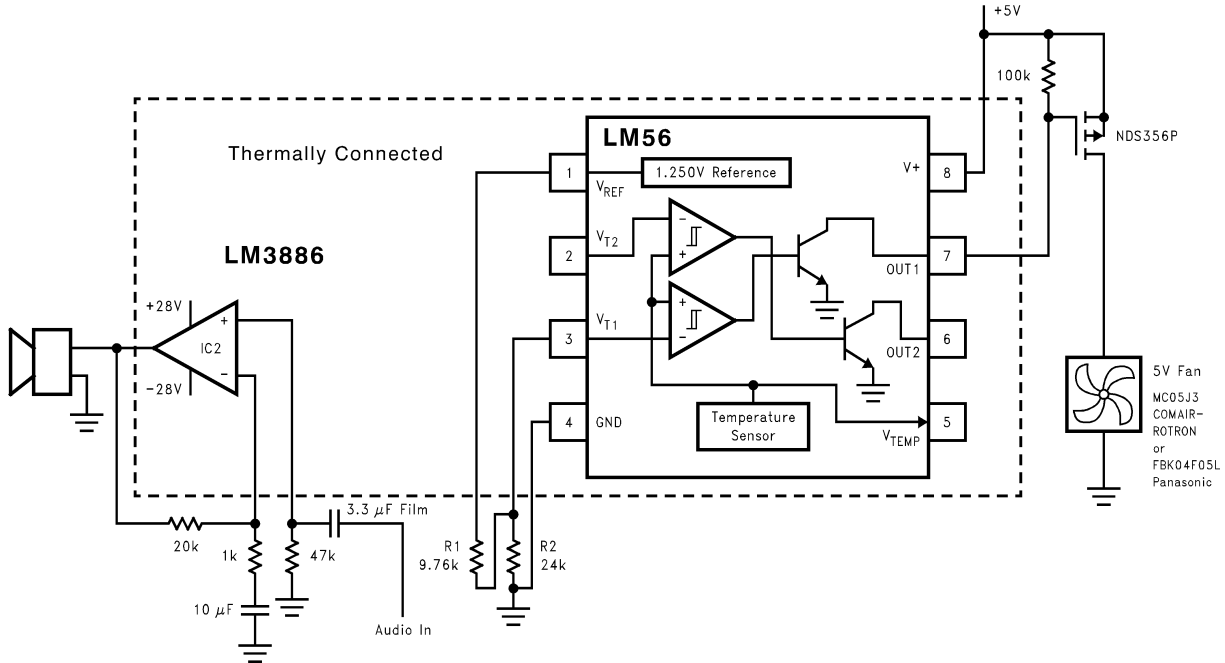

01289321

FIGURE 6. Audio Power Amplifier Overtemperature Detector

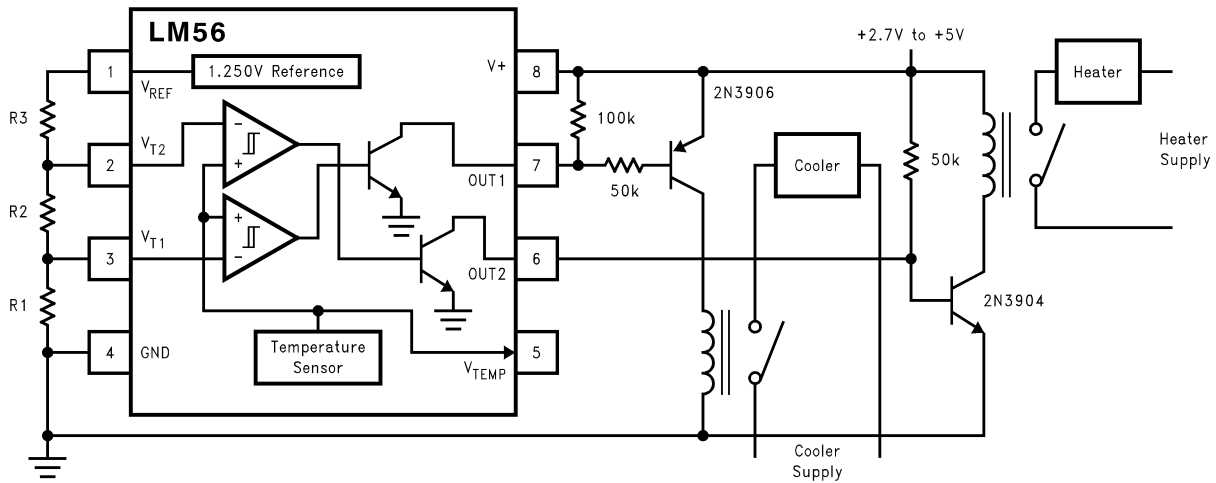

01289322

FIGURE 7. Simple Thermostat

**Physical Dimensions** inches (millimeters) unless otherwise noted

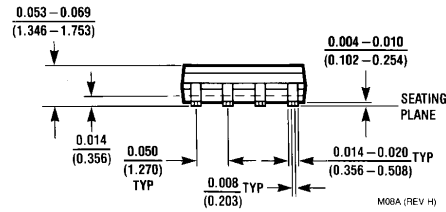
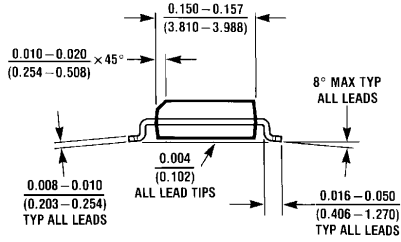
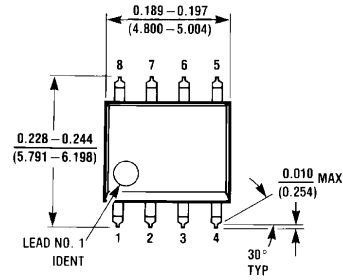

**8-Lead (0.150" Wide) Molded Small Outline Package, JEDEC  
Order Number LM56BIM, LM56BIMX, LM56CIM or LM56CIMX  
NS Package Number M08A**

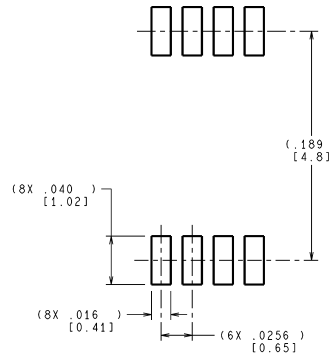
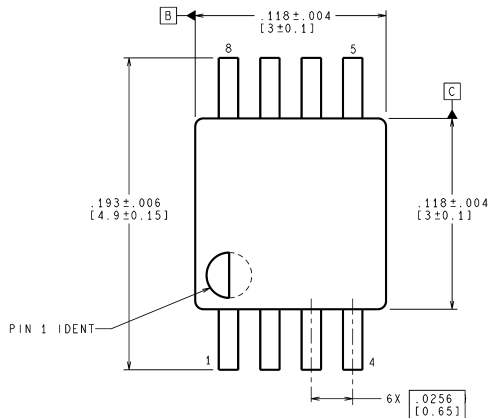

**LAND PATTERN RECOMMENDATION**

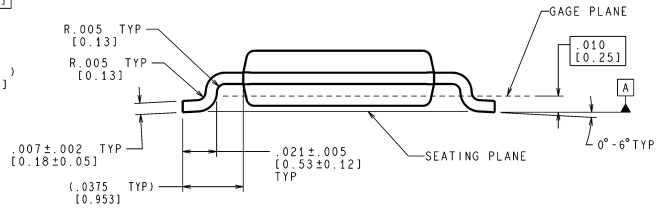
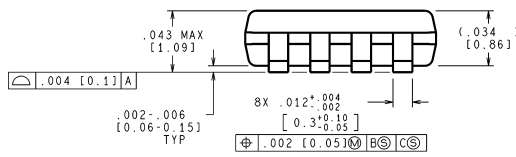

CONTROLLING DIMENSION IS INCH  
VALUES IN [ ] ARE MILLIMETERS

MUA08A (Rev E)

**8-Lead Molded Mini Small Outline Package (MSOP)  
(JEDEC REGISTRATION NUMBER M0-187)  
Order Number LM56BIMM, LM56BIMMX, LM56CIMM, or LM56CIMMX  
NS Package Number MUA08A**

## Notes

National does not assume any responsibility for use of any circuitry described, no circuit patent licenses are implied and National reserves the right at any time without notice to change said circuitry and specifications.

For the most current product information visit us at [www.national.com](http://www.national.com).

### LIFE SUPPORT POLICY

NATIONAL'S PRODUCTS ARE NOT AUTHORIZED FOR USE AS CRITICAL COMPONENTS IN LIFE SUPPORT DEVICES OR SYSTEMS WITHOUT THE EXPRESS WRITTEN APPROVAL OF THE PRESIDENT AND GENERAL COUNSEL OF NATIONAL SEMICONDUCTOR CORPORATION. As used herein:

- |  |   |
|--|---|
| <p>1. Life support devices or systems are devices or systems which, (a) are intended for surgical implant into the body, or (b) support or sustain life, and whose failure to perform when properly used in accordance with instructions for use provided in the labeling, can be reasonably expected to result in a significant injury to the user.</p> | <p>2. A critical component is any component of a life support device or system whose failure to perform can be reasonably expected to cause the failure of the life support device or system, or to affect its safety or effectiveness.</p> |
|--|---|

### BANNED SUBSTANCE COMPLIANCE

National Semiconductor manufactures products and uses packing materials that meet the provisions of the Customer Products Stewardship Specification (CSP-9-111C2) and the Banned Substances and Materials of Interest Specification (CSP-9-111S2) and contain no "Banned Substances" as defined in CSP-9-111S2.

Leadfree products are RoHS compliant.



**National Semiconductor**  
Americas Customer  
Support Center  
Email: [new.feedback@nsc.com](mailto:new.feedback@nsc.com)  
Tel: 1-800-272-9959

**National Semiconductor**  
Europe Customer Support Center  
Fax: +49 (0) 180-530 85 86  
Email: [europe.support@nsc.com](mailto:europe.support@nsc.com)  
Deutsch Tel: +49 (0) 69 9508 6208  
English Tel: +44 (0) 870 24 0 2171  
Français Tel: +33 (0) 1 41 91 8790

**National Semiconductor**  
Asia Pacific Customer  
Support Center  
Email: [ap.support@nsc.com](mailto:ap.support@nsc.com)

**National Semiconductor**  
Japan Customer Support Center  
Fax: 81-3-5639-7507  
Email: [jpn.feedback@nsc.com](mailto:jpn.feedback@nsc.com)  
Tel: 81-3-5639-7560