

FEATURES

- *Guaranteed* 0.5 ppm/°C temperature coefficient
- *Guaranteed* 1.0 Ω max. dynamic impedance
- *Guaranteed* 20 μ V RMS max. noise
- *Guaranteed* initial tolerance of 2%
- Wide operating current range

APPLICATIONS

- Precision voltage reference for multimeters
- Calibration equipment voltage standards
- Laboratory measurement equipment
- Industrial monitor/control instruments
- High accuracy data converters

DESCRIPTION

The LM199/399 precision reference features excellent temperature stability over a wide range of voltage, temperature, and operating current conditions. A stabilizing heater is incorporated with the active zener on a monolithic substrate which nearly eliminates changes in voltage with temperature. The subsurface zener operates over a current range of 0.5mA to 10mA, and offers minimal noise and excellent long term stability.

Ideal applications for the LM199/399 include digital voltmeters, precision calibration equipment, current sources and a variety of other precision low cost references. A 10 volt buffered reference application is shown below.

3

10 Volt Buffered Reference

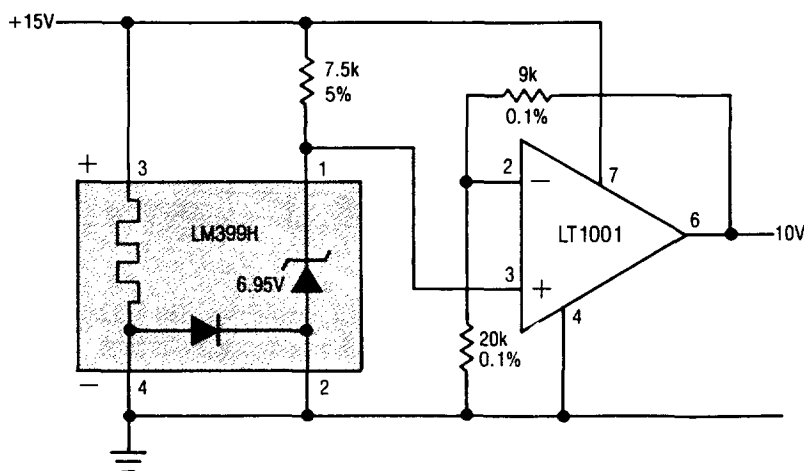

Reverse Voltage Change

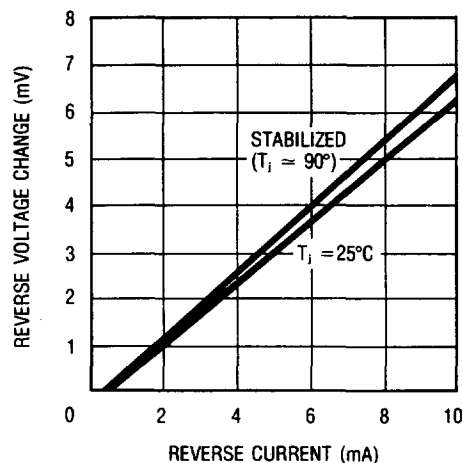

LM199/LM399 LM199A/LM399A

ABSOLUTE MAXIMUM RATINGS

Temperature Stabilizer	40V
Reverse Breakdown Current	20mA
Forward Current	1mA
Reference to Substrate Voltage $V_{(RS)}$, (Note 1).	-0.1V
Operating Temperature Range	
LM199/199A	-55°C to 125°C
LM399/399A	0°C to 70°C
Storage Temperature Range	
LM199/199A	-65°C to 150°C
LM399/399A	-65°C to 150°C
Lead Temperature (Soldering, 10 sec.)	300°C

PACKAGE/ORDER INFORMATION

TOP VIEW

H PKG.
TO-46 METAL CAN INSIDE THERMAL SHIELD

ORDER PART NO.

LM199H, LM199AH
LM399H, LM399AH
LM199AH-20, LM399AH-50

FUNCTIONAL BLOCK DIAGRAM

ELECTRICAL CHARACTERISTICS (See Note 2)

SYMBOL	PARAMETER	CONDITIONS	LM199/199A			LM399/399A			UNITS
			MIN	TYP	MAX	MIN	TYP	MAX	
V_Z	Reverse Breakdown Voltage	$0.5\text{mA} \leq I_R \leq 10\text{mA}$	● 6.8	6.95	7.1	6.75	6.95	7.3	V
ΔV_Z	Reverse Breakdown Voltage Change with Current	$0.5\text{mA} \leq I_R \leq 10\text{mA}$	●	6	9		6	12	mV
r_Z	Reverse Dynamic Impedance	$I_R = 1\text{mA}$ (Note 5) ($10 \leq f \leq 100\text{Hz}$)	●	0.5	1		0.5	1.5	Ω
$\frac{\Delta V_Z}{\Delta \text{Temp}}$	Temperature Coefficient LM199/LM399	-55°C ≤ T_A ≤ 85°C +85°C ≤ T_A ≤ 125°C 0°C ≤ T_A ≤ 70°C		0.3	1		0.3	2	ppm/°C ppm/°C ppm/°C
	LM199A/LM399A	-55°C ≤ T_A ≤ 85°C +85°C ≤ T_A ≤ 125°C 0°C ≤ T_A ≤ 70°C		0.2	0.5			1	ppm/°C ppm/°C ppm/°C
e_n	RMS Noise	$10\text{Hz} \leq f \leq 10\text{kHz}$	●	7	20		7	50	μV
$\frac{\Delta V_Z}{\Delta \text{Time}}$	Long Term Stability	Stabilized, 22°C ≤ T_A ≤ 28°C 1000 Hours, $I_R = 1\text{mA} \pm 0.1\%$		8	Note 3		8	Note 3	ppm/ $\sqrt{\text{kHz}}$
I_H	Temperature Stabilizer Supply Current	$T_A = +25^\circ\text{C}$, Still Air, $V_H = +30\text{V}$ $T_A = -55^\circ\text{C}$ (Note 4)		8.5	14		8.5	15	mA
V_H	Temperature Stabilizer Supply Voltage		●	9	40		9	40	V
	Warm-up Time to $\pm 0.05\% V_Z$	$V_H = 30\text{V}$, $T_A = 25^\circ\text{C}$		3			3		Seconds
	Initial Turn-on Current	$9\text{V} \leq V_H \leq 40\text{V}$, $T_A = 25^\circ\text{C}$, (See Note 4)		140	200		140	200	mA

The ● denotes the specifications which apply over full operating temperature range.

Note 1: The substrate is electrically connected to the negative terminal of the temperature stabilizer. The voltage that can be applied to either terminal of the reference is 40V more positive or 0.1V more negative than the substrate.

Note 2: These specifications apply for 30V applied to the temperature stabilizer and $-55^\circ\text{C} \leq T_A \leq 125^\circ\text{C}$ for the LM199; and $0^\circ\text{C} \leq T_A \leq 70^\circ\text{C}$ for the LM399.

Note 3: Devices with maximum guaranteed long term stability of 20 ppm/ $\sqrt{\text{kHz}}$ are available. Drift decreases with time.

Note 4: This initial current can be reduced by adding an appropriate resistor and capacitor to the heater circuit. See the performance characteristic graphs to determine values.

Note 5: Guaranteed by "Reverse Breakdown Change with Current."

TYPICAL PERFORMANCE CHARACTERISTICS

Reverse Characteristics

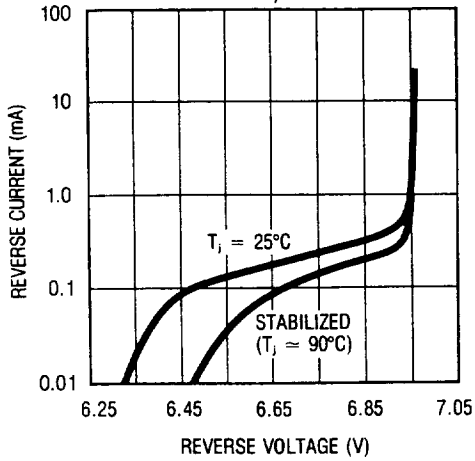

Dynamic Impedance

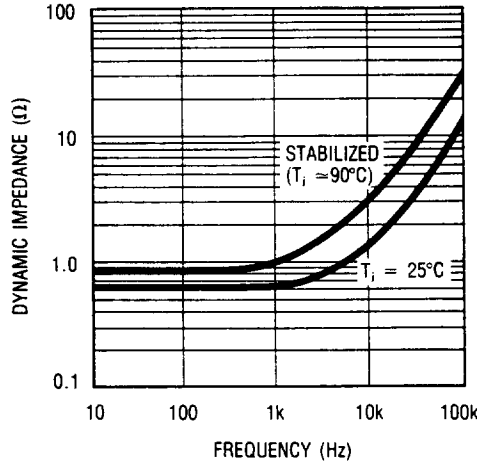

Stabilization Time

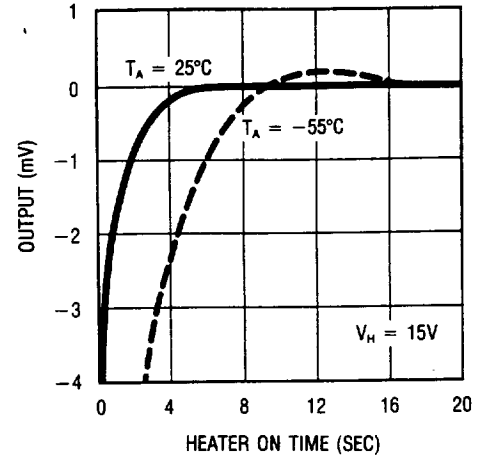

Initial Heater Current

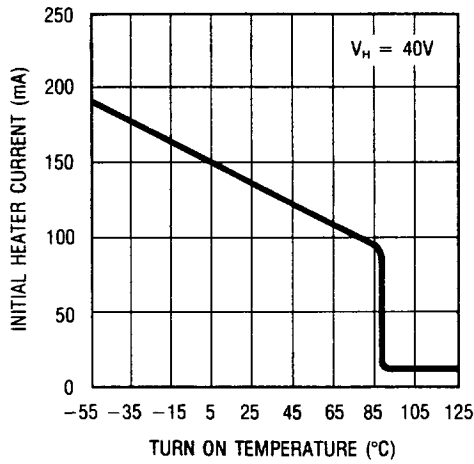

Heater Current

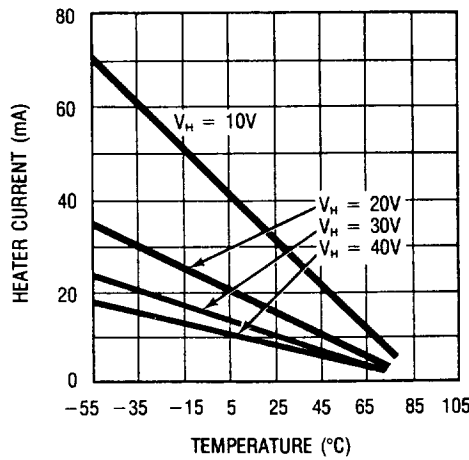

Heater Current

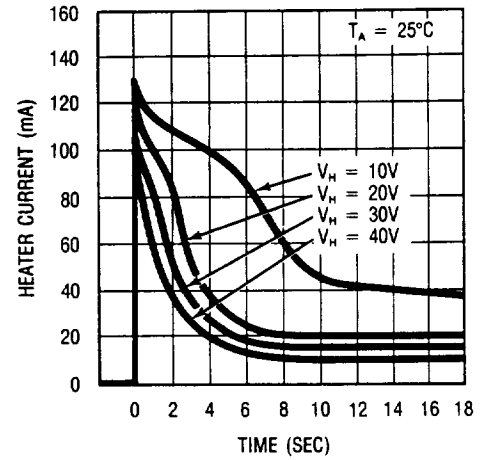

3

Zener Noise Voltage

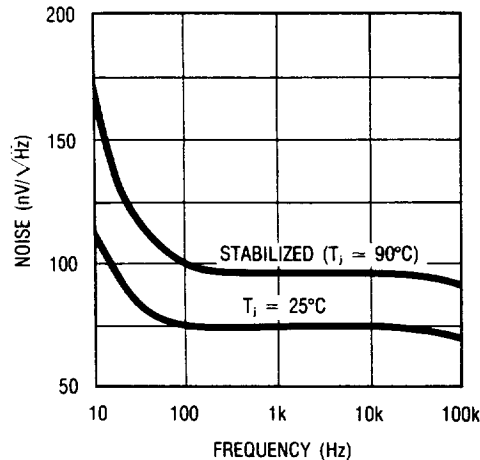

Response Time

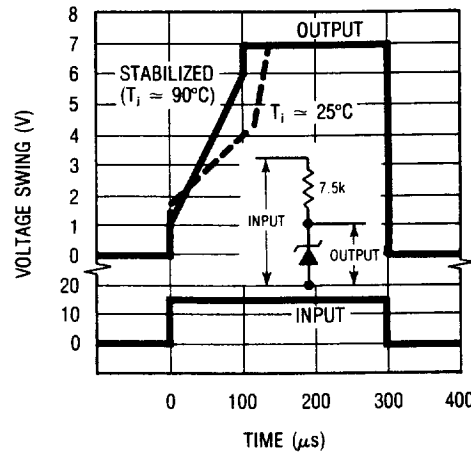

Limiting Surge Current

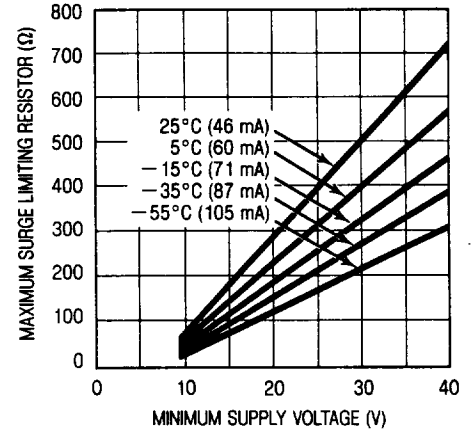

*Heater must be bypassed with a 2 μF or larger tantalum capacitor if resistors are used.

TYPICAL PERFORMANCE CHARACTERISTICS

Long Term Reference Performance
44 Units Tested

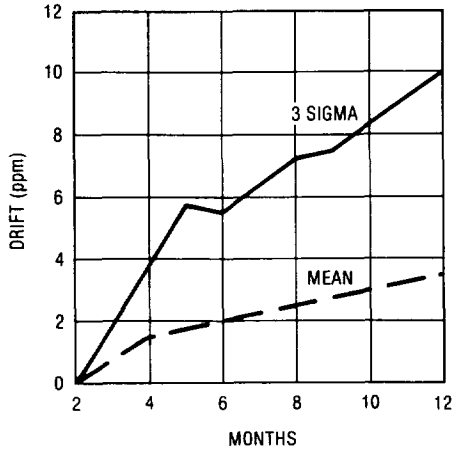

Low Frequency Noise Voltage

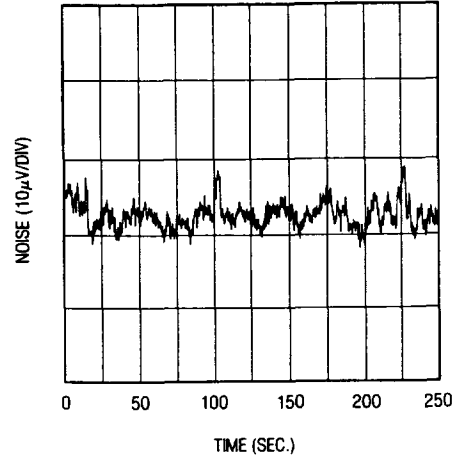

TYPICAL APPLICATIONS

Single Supply Operation

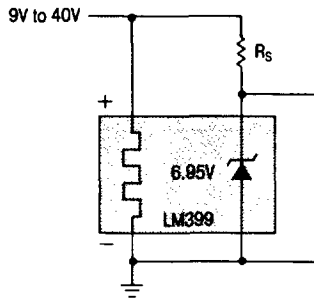

Split Supply Operation

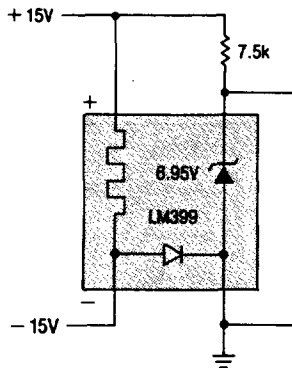

Negative Heater Supply with Positive Reference

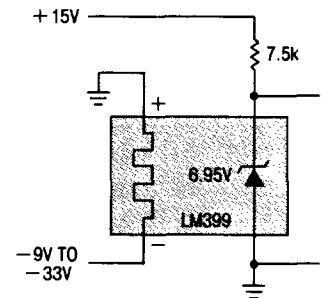

Standard Cell Replacement

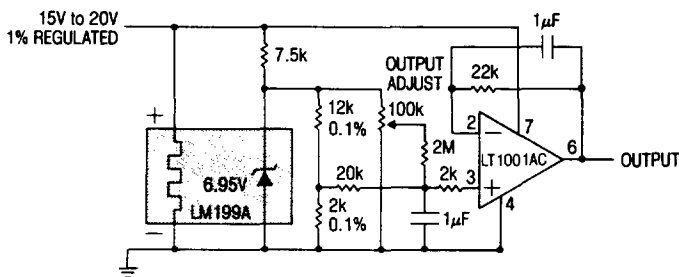

Portable Calibrator

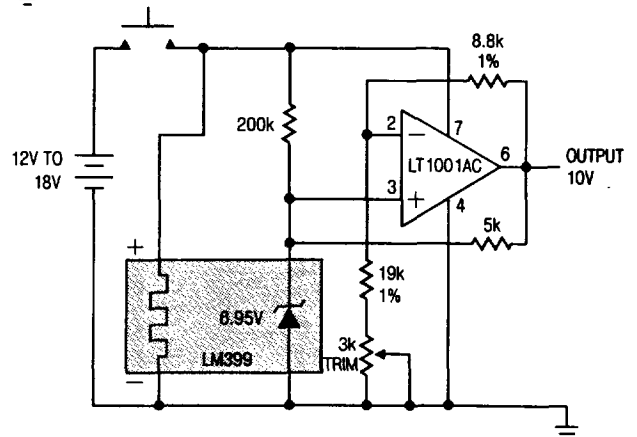

SCHEMATIC DIAGRAMS

Temperature Stabilizer

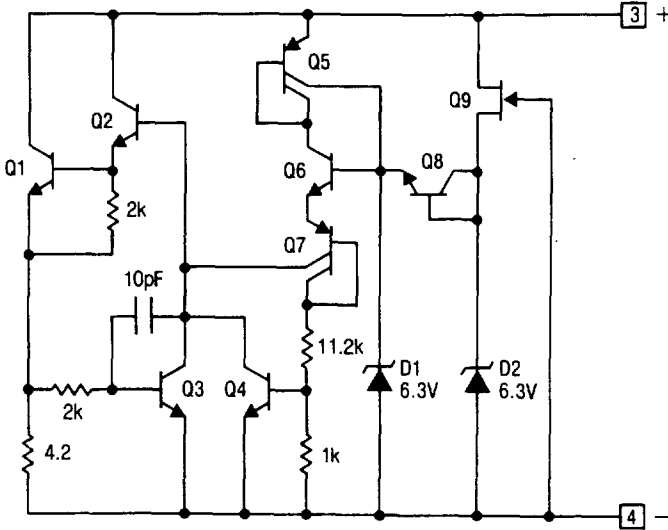

Reference

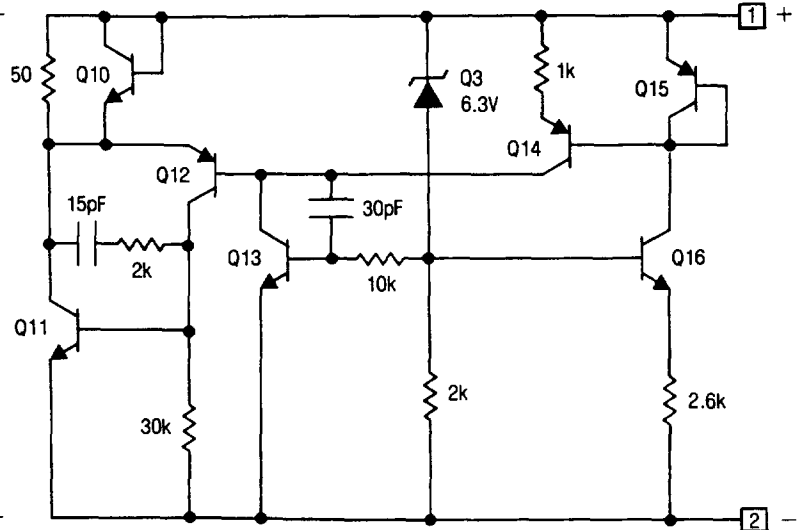

3

PACKAGE DESCRIPTION

H Package, 4 Lead
TO-46 Metal Can

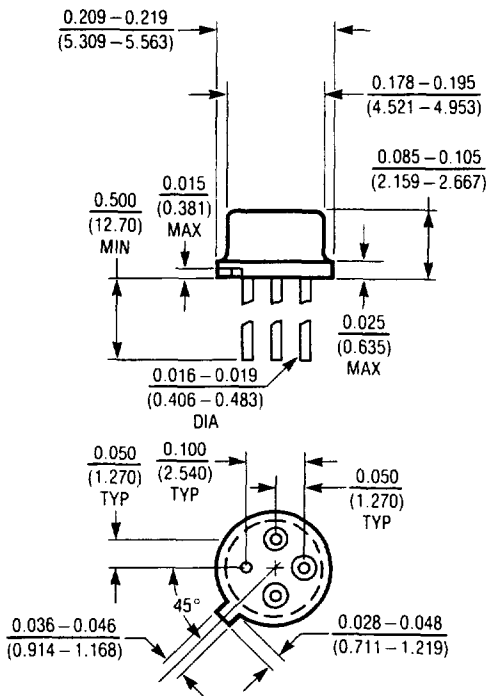

Thermal Shield*
For TO-46, H Package

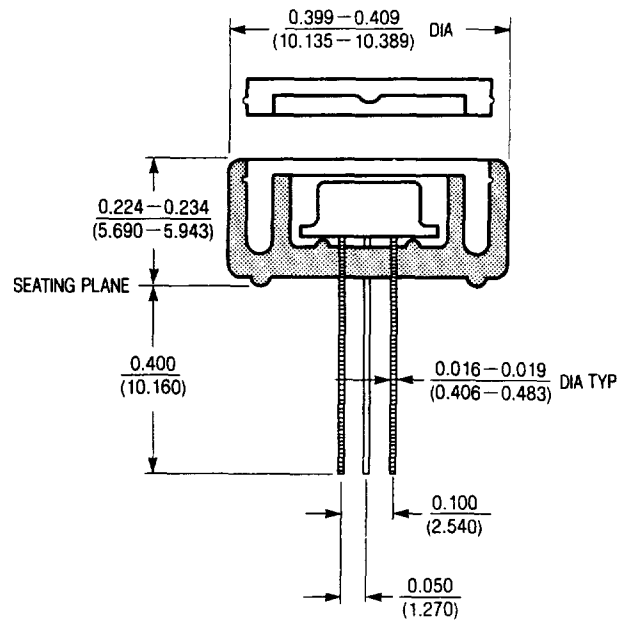

*Thermal Shield Material is Valox™
Valox is a registered trademark of General Electric