

# LM3429

## N-Channel Controller for Constant Current LED Drivers

### General Description

The LM3429 is a versatile high voltage N-channel MosFET controller for LED drivers. It can be easily configured in buck, boost, buck-boost and SEPIC topologies. This flexibility, along with an input voltage rating of 75V, makes the LM3429 ideal for illuminating LEDs in a very diverse, large family of applications.

Adjustable high-side current sense voltage allows for tight regulation of the LED current with the highest efficiency possible. The LM3429 uses Predictive Off-time (PRO) control, which is a combination of peak current-mode control and a predictive off-timer. This method of control eases the design of loop compensation while providing inherent input voltage feed-forward compensation.

The LM3429 includes a high-voltage startup regulator that operates over a wide input range of 4.5V to 75V. The internal PWM controller is designed for adjustable switching frequencies of up to 2.0 MHz, thus enabling compact solutions. Additional features include analog dimming, PWM dimming, over-voltage protection, under-voltage lock-out, cycle-by-cycle current limit, and thermal shutdown.

The LM3429 comes in a low profile, thermally efficient TSSOP EP 14-lead package.

### Features

- $V_{IN}$  range from 4.5V to 75V
- Adjustable current sense voltage
- High-side current sensing
- $2\Omega$ , 1A Peak MosFET gate driver
- Input under-voltage protection
- Over-voltage protection
- PWM dimming
- Analog dimming
- Cycle-by-cycle current limit
- Programmable switching frequency
- Thermal Shutdown
- TSSOP EP 14-lead package

### Applications

- LED Drivers
- Constant-Current Buck-Boost (or Flyback) Regulator
- Constant-Current Boost Regulator
- Constant-Current Buck Regulator
- Constant-Current SEPIC Regulator
- Thermo-Electric Cooler (Peltier) Driver

### Typical Application Circuit

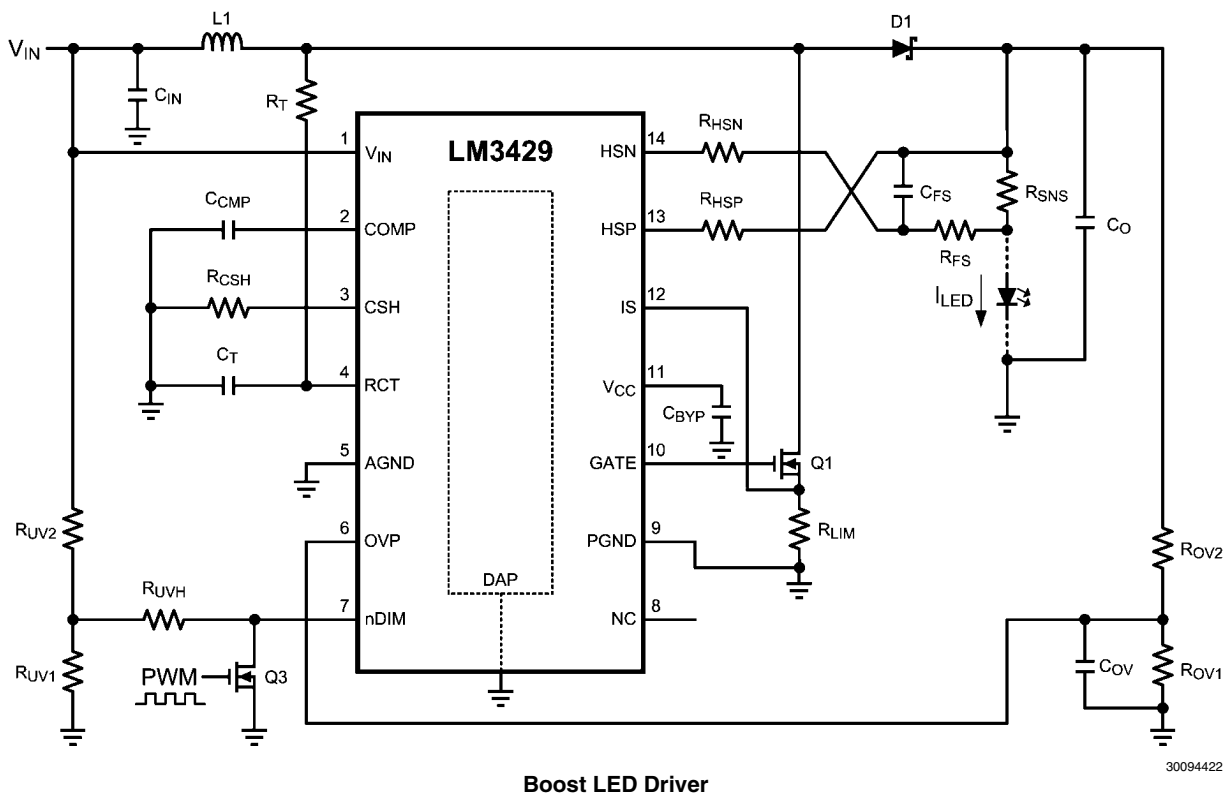

## Connection Diagram

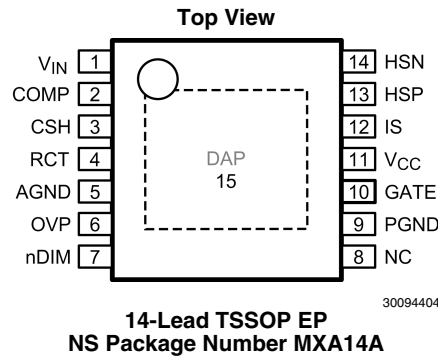

## Ordering Information

Order Number	Spec.	Package Type	NSC Package Drawing	Supplied As
LM3429MH	NOPB	TSSOP-14 EP	MXA14A	94 Units, Rail
LM3429MHX	NOPB	TSSOP-14 EP	MXA14A	2500 Units, Tape and Reel

## Pin Descriptions

Pin	Name	Description	Application Information
1	V <sub>IN</sub>	Input Voltage	Bypass with 100 nF capacitor to AGND as close to the device as possible in the circuit board layout.
2	COMP	Compensation	Connect a capacitor to AGND.
3	CSH	Current Sense High	Connect a resistor to AGND to set the signal current. For analog dimming, connect a controlled current source or a potentiometer to AGND as detailed in the <i>Analog Dimming</i> section.
4	RCT	Resistor Capacitor Timing	Connect a resistor from the switch node and a capacitor to AGND to set the switching frequency.
5	AGND	Analog Ground	Connect to PGND through the DAP copper circuit board pad to provide proper ground return for CSH, COMP, and RCT.
6	OVP	Over-Voltage Protection	Connect to a resistor divider from V <sub>O</sub> to program output over-voltage lockout (OVLO). Turn-off threshold is 1.24V and hysteresis for turn-on is provided by 20 μA current source.
7	nDIM	Not DIM input	Connect a PWM signal for dimming as detailed in the <i>PWM Dimming</i> section and/or a resistor divider from V <sub>IN</sub> to program input under-voltage lockout (UVLO). Turn-on threshold is 1.24V and hysteresis for turn-off is provided by 20 μA current source.
8	NC	No Connection	Leave open.
9	PGND	Power Ground	Connect to AGND through the DAP copper circuit board pad to provide proper ground return for GATE.
10	GATE	Gate Drive Output	Connect to the gate of the external NFET.
11	V <sub>CC</sub>	Internal Regulator Output	Bypass with a 2.2 μF–3.3 μF, ceramic capacitor to PGND.
12	IS	Main Switch Current Sense	Connect to the drain of the main N-channel MosFET switch for R <sub>DS-ON</sub> sensing or to a sense resistor installed in the source of the same device.
13	HSP	High-Side LED Current Sense Positive	Connect through a series resistor to the positive side of the LED current sense resistor.
14	HSN	High-Side LED Current Sense Negative	Connect through a series resistor to the negative side of the LED current sense resistor.
DAP (15)	DAP	Thermal pad on bottom of IC	Star ground, connecting AGND and PGND. For thermal considerations please refer to (Note 4) of the Electrical Characteristics table.

## Absolute Maximum Ratings (Notes 1, 2)

If Military/Aerospace specified devices are required, please contact the National Semiconductor Sales Office/ Distributors for availability and specifications.

$V_{IN}$ , nDIM	-0.3V to 76.0V -1 mA continuous
OVP, HSP, HSN	-0.3V to 76.0V -100 $\mu$ A continuous
RCT	-0.3V to 3.0V -1 mA to +5 mA continuous
IS	-0.3V to 76.0V -2V for 100 ns -1 mA continuous
$V_{CC}$ COMP, CSH	-0.3V to 8.0V -0.3V to 6.0V -200 $\mu$ A to +200 $\mu$ A Continuous
GATE	-0.3V to $V_{CC}$ -2.5V for 100 ns $V_{CC}+2.5V$ for 100 ns -1 mA to +1 mA continuous

PGND	-0.3V to 0.3V -2.5V to 2.5V for 100 ns
Junction Temperature	150°C
Storage Temperature Range	-65°C to +150°C
Maximum Lead Temperature (Reflow and Solder) (Note 5)	260°C
Continuous Power Dissipation (Note 4)	Internally Limited
ESD Susceptibility (Note 6)	
Human Body Model	2 kV

## Operating Conditions (Notes 1, 2)

Operating Junction Temperature Range	-40°C to +125°C
Input Voltage $V_{IN}$	4.5V to 75V

## Electrical Characteristics (Note 2)

Specifications in standard type face are for  $T_J = 25^\circ\text{C}$  and those with **boldface type** apply over the full **Operating Temperature Range** ( $T_J = -40^\circ\text{C}$  to  $+125^\circ\text{C}$ ). Minimum and Maximum limits are guaranteed through test, design, or statistical correlation. Typical values represent the most likely parametric norm at  $T_J = +25^\circ\text{C}$ , and are provided for reference purposes only. Unless otherwise stated the following condition applies:  $V_{IN} = +14V$ .

Symbol	Parameter	Conditions	Min (Note 7)	Typ (Note 8)	Max (Note 7)	Units
<b>STARTUP REGULATOR (<math>V_{CC}</math>)</b>						
$V_{CC-REG}$	$V_{CC}$ Regulation	$I_{CC} = 0$ mA	<b>6.30</b>	6.90	<b>7.35</b>	V
$I_{CC-LIM}$	$V_{CC}$ Current Limit	$V_{CC} = 0V$	<b>20</b>	27		mA
$I_Q$	Quiescent Current	Static		1.6	<b>3.0</b>	
$V_{CC-UVLO}$	$V_{CC}$ UVLO Threshold	$V_{CC}$ Increasing		4.17	<b>4.50</b>	V
		$V_{CC}$ Decreasing	<b>3.70</b>	4.08		
$V_{CC-HYS}$	$V_{CC}$ UVLO Hysteresis			0.1		
<b>OVER-VOLTAGE PROTECTION (OVP)</b>						
$V_{TH-OVP}$	OVP OVLO Threshold	OVP Increasing	<b>1.180</b>	1.240	<b>1.280</b>	V
$I_{HYS-OVP}$	OVP Hysteresis Source Current	OVP Active (high)	<b>10</b>	20	<b>30</b>	$\mu$ A
<b>ERROR AMPLIFIER</b>						
$V_{CSH}$	CSH Reference Voltage	With Respect to AGND	<b>1.210</b>	1.235	<b>1.260</b>	V
	Error Amplifier Input Bias Current		-0.6	0	0.6	$\mu$ A
	COMP Sink / Source Current		<b>10</b>	26	<b>40</b>	
	Transconductance			100		$\mu$ A/V
	Linear Input Range	(Note 9)		$\pm 125$		mV
	Transconductance Bandwidth	-6dB Unloaded Response (Note 9)	0.5	1.0		MHz
<b>OFF TIMER (RCT)</b>						
$t_{OFF-MIN}$	Minimum Off-time	RCT = 1V through 1 k $\Omega$		35	<b>75</b>	ns
$R_{RCT}$	RCT Reset Pull-down Resistance			36	<b>120</b>	$\Omega$
$V_{RCT}$	$V_{IN}/25$ Reference Voltage	$V_{IN} = 14V$	<b>540</b>	565	<b>585</b>	mV

Symbol	Parameter	Conditions	Min (Note 7)	Typ (Note 8)	Max (Note 7)	Units
<b>PWM COMPARATOR</b>						
	COMP to PWM Offset		<b>700</b>	800	<b>900</b>	mV
<b>CURRENT LIMIT (IS)</b>						
$V_{LIM}$	Current Limit Threshold		<b>215</b>	245	<b>275</b>	mV
	$V_{LIM}$ Delay to Output			35	<b>75</b>	ns
$t_{ON-MIN}$	Leading Edge Blanking Time		<b>75</b>	250	<b>450</b>	
<b>HIGH SIDE TRANSCONDUCTANCE AMPLIFIER</b>						
	Input Bias Current			10		$\mu$ A
	Transconductance		<b>20</b>	119		mA/V
	Input Offset Current		<b>-1.5</b>	0	<b>1.5</b>	$\mu$ A
	Input Offset Voltage		<b>-7</b>	0	<b>7</b>	mV
	Transconductance Bandwidth	$I_{CSH} = 100 \mu\text{A}$ (Note 9)	250	500		kHz
<b>GATE DRIVER (GATE)</b>						
$R_{SRC(GATE)}$	GATE Sourcing Resistance	GATE = High		2.0	<b>6.0</b>	$\Omega$
$R_{SNK(GATE)}$	GATE Sinking Resistance	GATE = Low		1.3	<b>4.5</b>	
<b>UNDER-VOLTAGE LOCKOUT and DIM INPUT (nDIM)</b>						
$V_{TH-nDIM}$	nDIM / UVLO Threshold		<b>1.180</b>	1.240	<b>1.280</b>	V
$I_{HYS-nDIM}$	nDIM Hysteresis Current		<b>10</b>	20	<b>30</b>	$\mu$ A
<b>THERMAL SHUTDOWN</b>						
$T_{SD}$	Thermal Shutdown Threshold	(Notes 3, 9)		165		$^{\circ}$ C
$T_{HYS}$	Thermal Shutdown Hysteresis	(Notes 3, 9)		25		
<b>THERMAL RESISTANCE</b>						
$\theta_{JA}$	Junction to Ambient (Note 4)	14L TSSOP EP		40		$^{\circ}$ C/W
$\theta_{JC}$	Junction to Exposed Pad (DAP)	14L TSSOP EP		5.5		$^{\circ}$ C/W

**Note 1:** Absolute Maximum Ratings indicate limits beyond which damage to the device may occur, including inoperability and degradation of device reliability and/or performance. Functional operation of the device and/or non-degradation at the Absolute Maximum Ratings or other conditions beyond those indicated in the Operating Ratings is not implied. The recommended Operating Ratings indicate conditions at which the device is functional and the device should not be operated beyond such conditions.

**Note 2:** All voltages are with respect to the potential at the AGND pin, unless otherwise specified.

**Note 3:** Internal thermal shutdown circuitry protects the device from permanent damage. Thermal shutdown engages at  $T_J=165^{\circ}\text{C}$  (typical) and disengages at  $T_J=140^{\circ}\text{C}$  (typical).

**Note 4:** Junction-to-ambient thermal resistance is highly board-layout dependent. The numbers listed in the table are given for a reference layout wherein the 14L TSSOP EP package has its DAP pad populated with 9 vias. In applications where high maximum power dissipation exists, namely driving a large MosFET at high switching frequency from a high input voltage, special care must be paid to thermal dissipation issues during board design. In high-power dissipation applications, the maximum ambient temperature may have to be derated. Maximum ambient temperature ( $T_{A-MAX}$ ) is dependent on the maximum operating junction temperature ( $T_{J-MAX-OP} = 125^{\circ}\text{C}$ ), the maximum power dissipation of the device in the application ( $P_{D-MAX}$ ), and the junction-to ambient thermal resistance of the package in the application ( $\theta_{JA}$ ), as given by the following equation:  $T_{A-MAX} = T_{J-MAX-OP} - (\theta_{JA} \times P_{D-MAX})$ . In most applications there is little need for the full power dissipation capability of this advanced package. Under these circumstances, no vias would be required and the thermal resistances would be  $104^{\circ}\text{C/W}$  for the 14L TSSOP EP. It is possible to conservatively interpolate between the full via count thermal resistance and the no via count thermal resistance with a straight line to get a thermal resistance for any number of vias in between these two limits.

**Note 5:** Refer to National's packaging website for more detailed information and mounting techniques. <http://www.national.com/analog/packaging/>

**Note 6:** Human Body Model, applicable std. JESD22-A114-C.

**Note 7:** All limits guaranteed at room temperature (standard typeface) and at temperature extremes (bold typeface). All room temperature limits are 100% production tested. All limits at temperature extremes are guaranteed via correlation using standard Statistical Quality Control (SQC) methods. All limits are used to calculate Average Outgoing Quality Level (AOQL).

**Note 8:** Typical numbers are at  $25^{\circ}\text{C}$  and represent the most likely norm.

**Note 9:** These electrical parameters are guaranteed by design, and are not verified by test.

**Note 10:** The measurements were made using the standard buck-boost evaluation board from AN-1985.

**Note 11:** The measurements were made using the standard boost evaluation board from AN-1986.

# Typical Performance Characteristics

$T_A = +25^\circ\text{C}$  and  $V_{IN} = 14\text{V}$  unless otherwise specified

**Boost Efficiency vs. Input Voltage**  
 $V_O = 32\text{V}$  (9 LEDs) (Note 11)

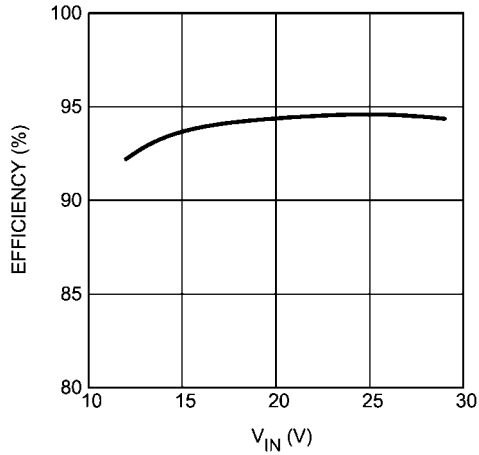

300944b6

**Buck-Boost Efficiency vs. Input Voltage**  
 $V_O = 20\text{V}$  (6 LEDs) (Note 10)

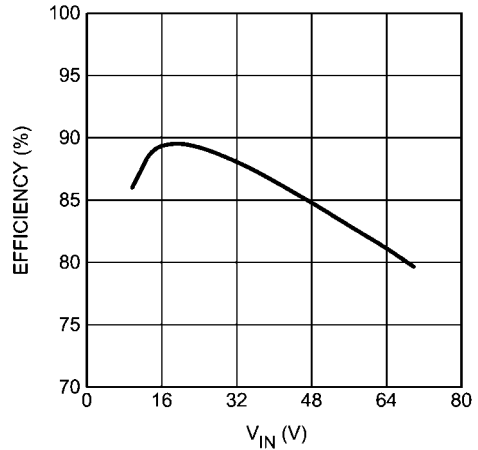

300944b5

**Boost LED Current vs. Input Voltage**  
 $V_O = 32\text{V}$  (9 LEDs) (Note 11)

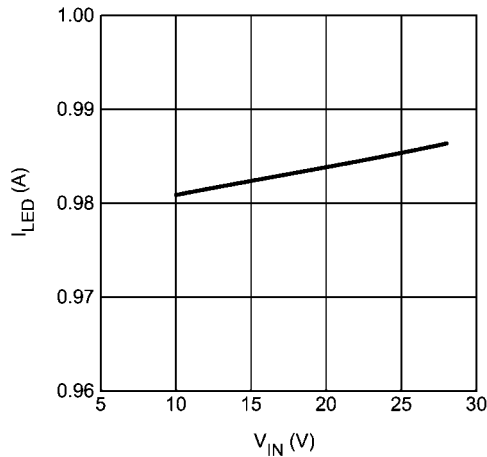

300944b8

**Buck-boost LED Current vs. Input Voltage**  
 $V_O = 20\text{V}$  (6 LEDs) (Note 10)

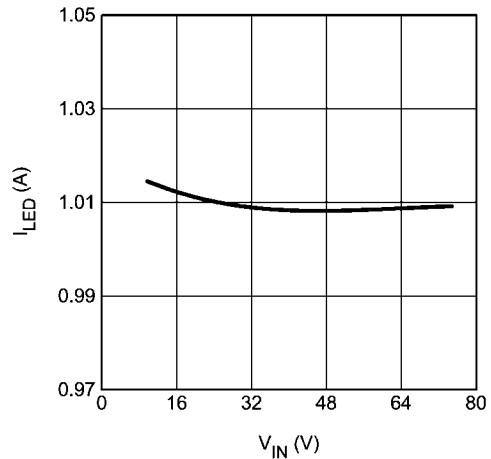

300944b7

**Analog Dimming**  
 $V_O = 20\text{V}$  (6 LEDs) (Note 10)

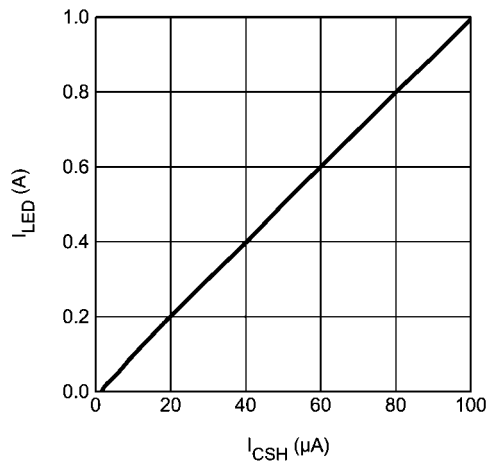

300944b9

**PWM Dimming**  
 $V_O = 20\text{V}$  (6 LEDs) (Note 10)

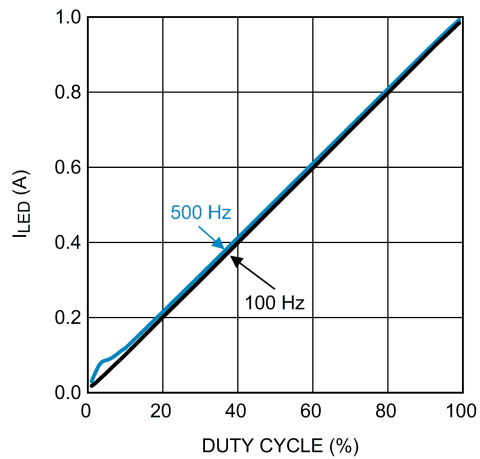

300944c0

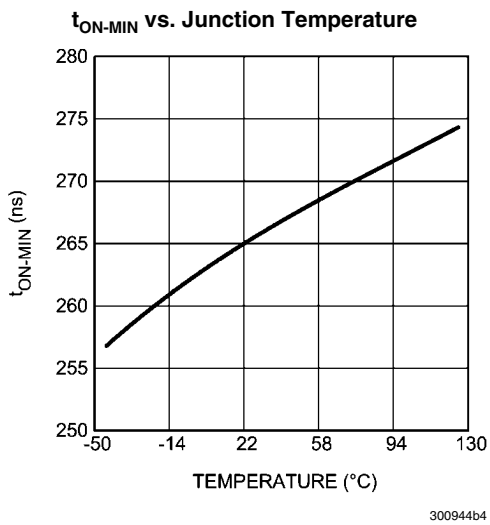
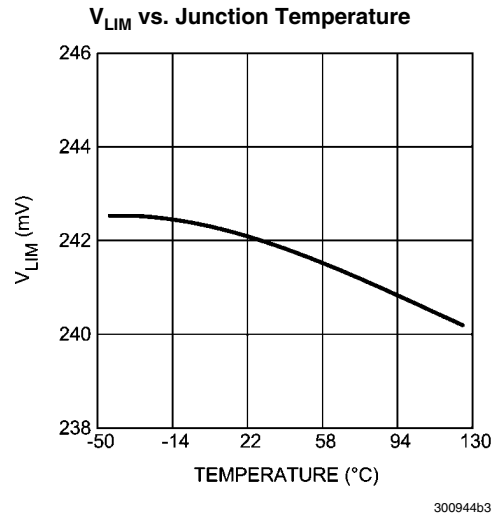
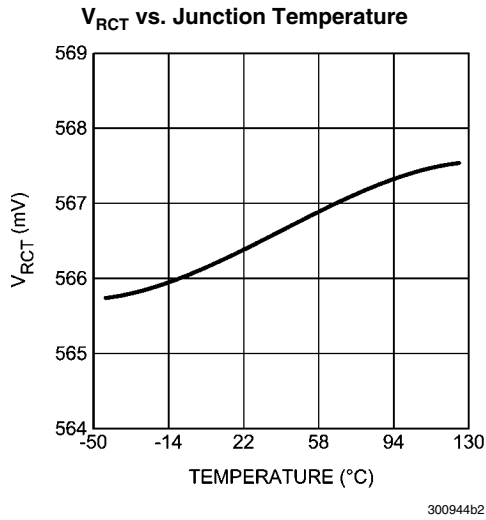
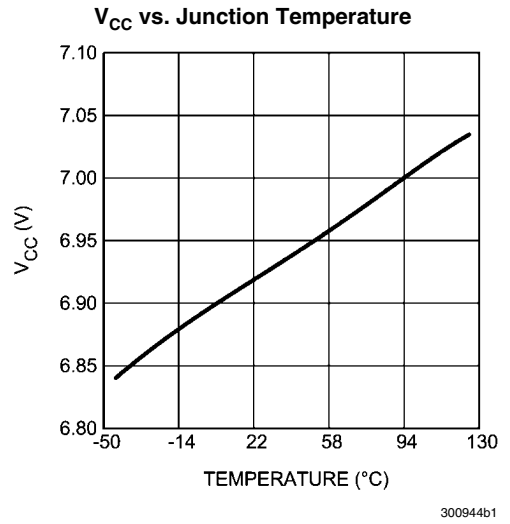
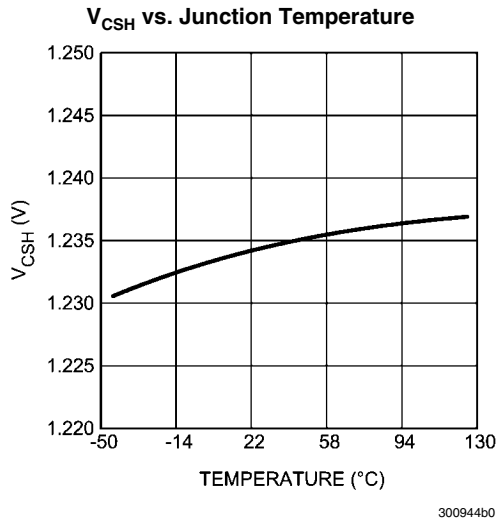

## Block Diagram

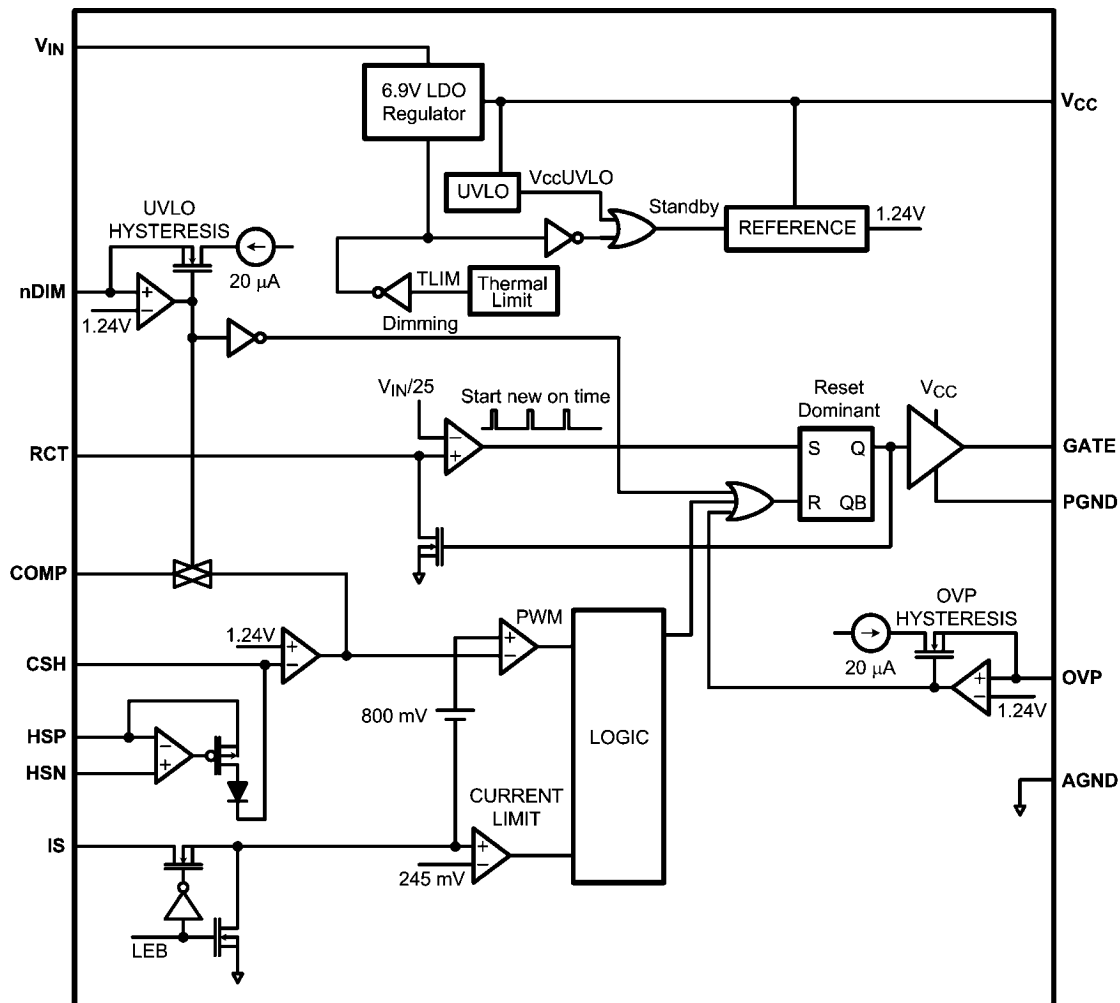

30094403

## Theory of Operation

The LM3429 is an N-channel MosFET (NFET) controller for buck, boost and buck-boost current regulators which are ideal for driving LED loads. The controller has wide input voltage range allowing for regulation of a variety of LED loads. The high-side differential current sense, with low adjustable threshold voltage, provides an excellent method for regulating output current while maintaining high system efficiency. The LM3429 uses a Predictive Off-time (PRO) control architecture that allows the regulator to be operated using minimal external control loop compensation, while providing an inherent cycle-by-cycle current limit. The adjustable current sense threshold provides the capability to amplitude (analog) dim the LED current and the output enable/disable function allows for PWM dimming using no external components. When designing, the maximum attainable LED current is not internally limited because the LM3429 is a controller. Instead it is a function of the system operating point, component choices, and switching frequency allowing the LM3429 to easily provide constant currents up to 5A. This simple controller contains all the features necessary to implement a high efficiency versatile LED driver.

## CURRENT REGULATORS

Current regulators can be designed to accomplish three basic functions: buck, boost, and buck-boost. All three topologies in their most basic form contain a main switching MosFET, a recirculating diode, an inductor and capacitors. The LM3429 is designed to drive a ground referenced NFET which is perfect for a standard boost regulator. Buck and buck-boost regulators, on the other hand, usually have a high-side switch. When driving an LED load, a ground referenced load is often not necessary, therefore a ground referenced switch can be used to drive a floating load instead. The LM3429 can then be used to drive all three basic topologies as shown in the *Basic Topology Schematics* section.

Looking at the buck-boost design, the basic operation of a current regulator can be analyzed. During the time that the NFET (Q1) is turned on ( $t_{ON}$ ), the input voltage source stores energy in the inductor (L1) while the output capacitor ( $C_O$ ) provides energy to the LED load. When Q1 is turned off ( $t_{OFF}$ ), the re-circulating diode (D1) becomes forward biased and L1 provides energy to both  $C_O$  and the LED load. *Figure 1* shows the inductor current ( $i_L(t)$ ) waveform for a regulator operating in CCM.

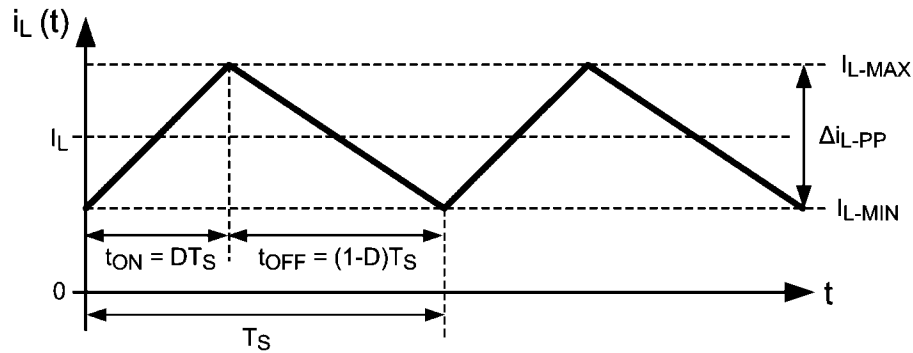

30094498

FIGURE 1. Ideal CCM Regulator Inductor Current  $i_L(t)$

The average output LED current ( $I_{LED}$ ) is proportional to the average inductor current ( $I_L$ ), therefore if  $I_L$  is tightly controlled,  $I_{LED}$  will be well regulated. As the system changes input voltage or output voltage, the ideal duty cycle ( $D$ ) is varied to regulate  $I_L$  and ultimately  $I_{LED}$ . For any current regulator,  $D$  is a function of the conversion ratio:

#### Buck

$$D = \frac{V_O}{V_{IN}}$$

#### Boost

$$D = \frac{V_O - V_{IN}}{V_O}$$

#### Buck-boost

$$D = \frac{V_O}{V_O + V_{IN}}$$

### PREDICTIVE OFF-TIME (PRO) CONTROL

PRO control is used by the LM3429 to control  $I_{LED}$ . It is a combination of average peak current control and a one-shot off-timer that varies with input voltage. The LM3429 uses peak current control to regulate the average LED current through an array of HBLEDs. This method of control uses a series resistor in the LED path to sense LED current and can use either a series resistor in the MosFET path or the MosFET  $R_{DS-ON}$  for both cycle-by-cycle current limit and input voltage feed forward.  $D$  is indirectly controlled by changes in both  $t_{OFF}$  and  $t_{ON}$ , which vary depending on the operating point.

Even though the off-time control is quasi-hysteretic, the input voltage proportionality in the off-timer creates an essentially constant switching frequency over the entire operating range for boost and buck-boost topologies. The buck topology can be designed to give constant ripple over either input voltage or output voltage, however switching frequency is only constant at a specific operating point.

This type of control minimizes the control loop compensation necessary in many switching regulators, simplifying the design process. The averaging mechanism in the peak detection control loop provides extremely accurate LED current regulation over the entire operating range.

PRO control was designed to mitigate “current mode instability” (also called “sub-harmonic oscillation”) found in standard peak current mode control when operating near or above 50% duty cycles. When using standard peak current mode control with a fixed switching frequency, this condition is present, regardless of the topology. However, using a constant off-time approach, current mode instability cannot occur, enabling easier design and control.

Predictive off-time advantages:

- There is no current mode instability at any duty cycle.
- Higher duty cycles / voltage transformation ratios are possible, especially in the boost regulator.

The only disadvantage is that synchronization to an external reference frequency is generally not available.

### SWITCHING FREQUENCY

An external resistor ( $R_T$ ) connected between the RCT pin and the switch node (where D1, Q1, and L1 connect), in combination with a capacitor ( $C_T$ ) between the RCT and AGND pins, sets the off-time ( $t_{OFF}$ ) as shown in *Figure 2*. For boost and buck-boost topologies, the  $V_{IN}$  proportionality ensures a virtually constant switching frequency ( $f_{SW}$ ).

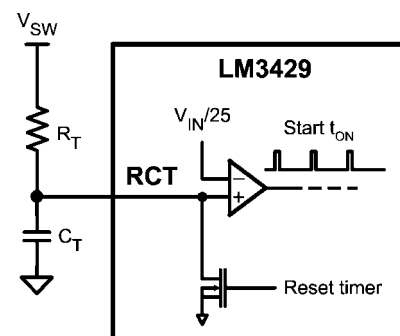

30094499

FIGURE 2. Off-timer Circuitry for Boost and Buck-boost Regulators

For a buck topology,  $R_T$  and  $C_T$  are also used to set  $t_{OFF}$ , however the  $V_{IN}$  proportionality will not ensure a constant switching frequency. Instead, constant ripple operation can be achieved. Changing the connection of  $R_T$  in *Figure 2* from  $V_{SW}$  to  $V_{IN}$  will provide a constant ripple over varying  $V_{IN}$ .



Adding a PNP transistor as shown in *Figure 3* will provide constant ripple over varying  $V_O$ .

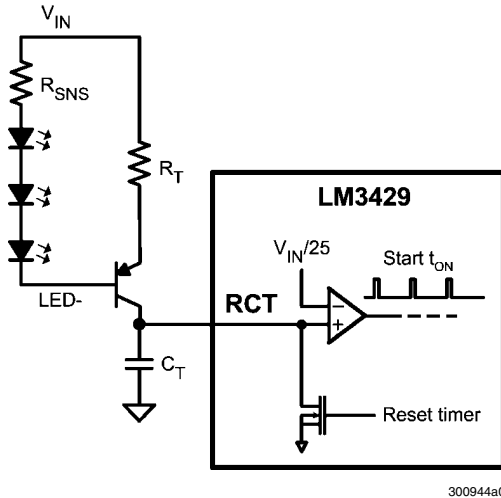

FIGURE 3. Off-timer Circuitry for Buck Regulators

The switching frequency is defined:

**Buck (Constant Ripple vs.  $V_{IN}$ )**

$$f_{SW} = \frac{25 \times (V_{IN} - V_O)}{R_T \times C_T \times V_{IN}}$$

**Buck (Constant Ripple vs.  $V_O$ )**

$$f_{SW} = \frac{25 \times (V_{IN} \times V_O - V_O^2)}{R_T \times C_T \times V_{IN}^2}$$

**Boost and Buck-boost**

$$f_{SW} = \frac{25}{R_T \times C_T}$$

For all topologies, the  $C_T$  capacitor is recommended to be 1 nF and should be located very close to the LM3429.

**AVERAGE LED CURRENT**

The LM3429 uses an external current sense resistor ( $R_{SNS}$ ) placed in series with the LED load to convert the LED current ( $I_{LED}$ ) into a voltage ( $V_{SNS}$ ) as shown in *Figure 4*. The HSP and HSN pins are the inputs to the high-side sense amplifier which are forced to be equal potential ( $V_{HSP}=V_{HSN}$ ) through negative feedback. Because of this, the  $V_{SNS}$  voltage is forced across  $R_{HSP}$  to generate the signal current ( $I_{CSH}$ ) which flows out of the CSH pin and through the  $R_{CSH}$  resistor. The error amplifier will regulate the CSH pin to 1.24V, therefore  $I_{CSH}$  can be calculated:

$$I_{CSH} = \frac{V_{SNS}}{R_{HSP}}$$

This means  $V_{SNS}$  will be regulated as follows:

$$V_{SNS} = 1.24V \times \frac{R_{HSP}}{R_{CSH}}$$

$I_{LED}$  can then be calculated:

$$I_{LED} = \frac{V_{SNS}}{R_{SNS}} = \frac{1.24V}{R_{SNS}} \times \frac{R_{HSP}}{R_{CSH}}$$

The selection of the three resistors ( $R_{SNS}$ ,  $R_{CSH}$ , and  $R_{HSP}$ ) is not arbitrary. For matching and noise performance, the suggested signal current  $I_{CSH}$  is approximately 100  $\mu A$ . This current does not flow in the LEDs and will not affect either the off state LED current or the regulated LED current.  $I_{CSH}$  can be above or below this value, but the high-side amplifier offset characteristics may be affected slightly. In addition, to minimize the effect of the high-side amplifier voltage offset on LED current accuracy, the minimum  $V_{SNS}$  is suggested to be 50 mV. Finally, a resistor ( $R_{HSN} = R_{HSP}$ ) should be placed in series with the HSN pin to cancel out the effects of the input bias current ( $\sim 10 \mu A$ ) of both inputs of the high-side sense amplifier. Note that the CSH pin can also be used as a low-side current sense input regulated to the 1.24V. The high-side sense amplifier is disabled if HSP and HSN are tied to GND.

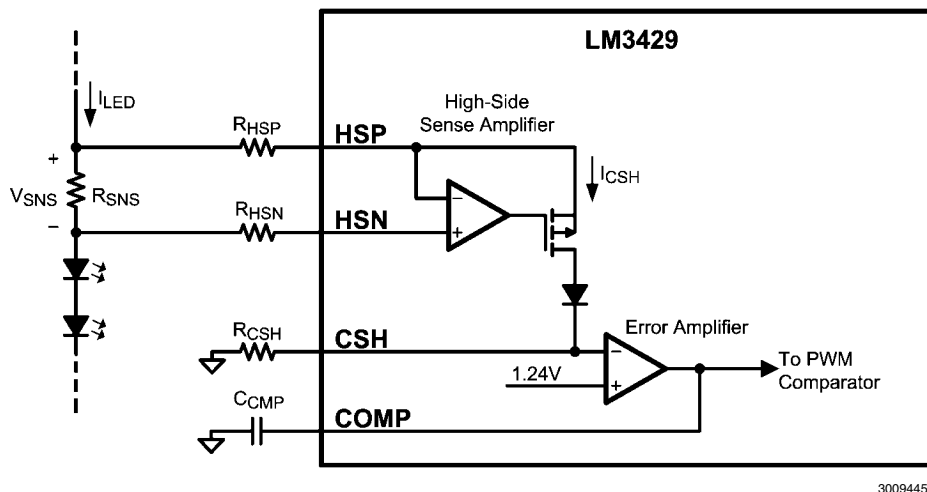

FIGURE 4. LED Current Sense Circuitry

**ANALOG DIMMING**

The CSH pin can be used to analog dim the LED current by adjusting the current sense voltage ( $V_{SNS}$ ). There are several different methods to adjust  $V_{SNS}$  using the CSH pin:

1. External variable resistance : Adjust a potentiometer placed in series with  $R_{CSH}$  to vary  $V_{SNS}$ .
2. External variable current source: Source current ( $0 \mu A$  to  $I_{CSH}$ ) into the CSH pin to adjust  $V_{SNS}$ .

In general, analog dimming applications require a lower switching frequency to minimize the effect of the leading edge blanking circuit. As the LED current is reduced, the output voltage and the duty cycle decreases. Eventually, the minimum on-time is reached. The lower the switching frequency, the wider the linear dimming range. Figure 5 shows how both methods are physically implemented.

Method 1 uses an external potentiometer in the CSH path which is a simple addition to the existing circuitry. However, the LEDs cannot dim completely because there is always some resistance causing signal current to flow. This method is also susceptible to noise coupling at the CSH pin since the potentiometer increases the size of the signal current loop.

Method 2 provides a complete dimming range and better noise performance, though it is more complex. It consists of a PNP current mirror and a bias network consisting of an NPN, 2 resistors and a potentiometer ( $R_{ADJ}$ ), where  $R_{ADJ}$  controls the amount of current sourced into the CSH pin. A higher resistance value will source more current into the CSH pin causing less regulated signal current through  $R_{HSP}$ , effectively dimming the LEDs.  $V_{REF}$  should be a precise external voltage reference, while Q7 and Q8 should be a dual pair PNP for best matching and performance. The additional current ( $I_{ADD}$ ) sourced into the CSH pin can be calculated:

$$I_{ADD} = \frac{\left( \frac{R_{ADJ} \times V_{REF}}{R_{ADJ} + R_{MAX}} \right) - V_{BE-Q6}}{R_{BIAS}}$$

The corresponding  $I_{LED}$  for a specific  $I_{ADD}$  is:

$$I_{LED} = (I_{CSH} - I_{ADD}) \times \left( \frac{R_{HSP}}{R_{SNS}} \right)$$

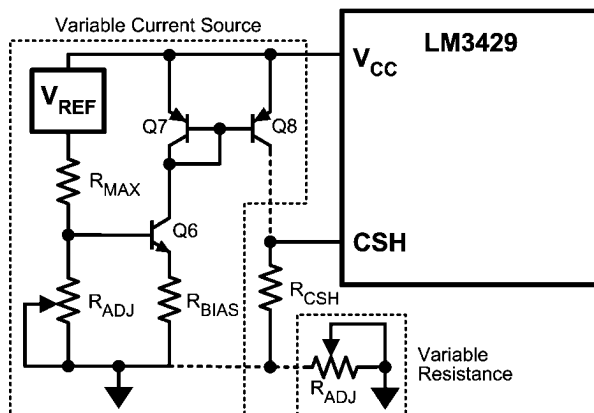

**FIGURE 5. Analog Dimming Circuitry**

**CURRENT SENSE/CURRENT LIMIT**

The LM3429 achieves peak current mode control using a comparator that monitors the MosFET transistor current, comparing it with the COMP pin voltage as shown in Figure 6. Further, it incorporates a cycle-by-cycle over-current protection function. Current limit is accomplished by a redundant internal current sense comparator. If the voltage at the current sense comparator input (IS) exceeds 245 mV (typical), the on cycle is immediately terminated. The IS input pin has an internal N-channel MosFET which pulls it down at the conclusion of every cycle. The discharge device remains on an additional 250 ns (typical) after the beginning of a new cycle to blank the leading edge spike on the current sense signal. The leading edge blanking (LEB) determines the minimum achievable on-time ( $t_{ON-MIN}$ ).

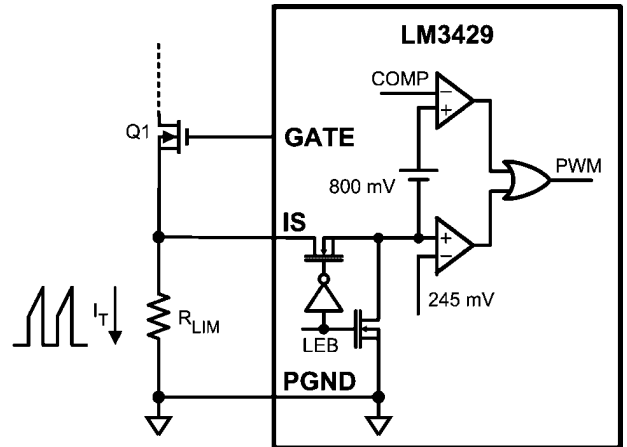

**FIGURE 6. Current Sense / Current Limit Circuitry**

There are two possible methods to sense the transistor current. The  $R_{DS-ON}$  of the main power MosFET can be used as the current sense resistance because the IS pin was designed to withstand the high voltages present on the drain when the MosFET is in the off state. Alternatively, a sense resistor located in the source of the MosFET may be used for current sensing, however a low inductance (ESL) type is suggested. The cycle-by-cycle current limit ( $I_{LIM}$ ) can be calculated using either method as the limiting resistance ( $R_{LIM}$ ):

$$I_{LIM} = \frac{245 \text{ mV}}{R_{LIM}}$$

In general, the external series resistor allows for more design flexibility, however it is important to ensure all of the noise sensitive low power ground connections are connected together local to the controller and a single connection is made to the high current PGND (sense resistor ground point).

300944a2

300944a1

**CONTROL LOOP COMPENSATION**

The LM3429 control loop is modeled like any current mode controller. Using a first order approximation, the uncompensated loop can be modeled as a single pole created by the output capacitor and, in the boost and buck-boost topologies, a right half plane zero created by the inductor, where both have a dependence on the LED string dynamic resistance. There is also a high frequency pole in the model, however it is above the switching frequency and plays no part in the compensation design process therefore it will be neglected. Since ceramic capacitance is recommended for use with LED drivers due to long lifetimes and high ripple current rating, the ESR of the output capacitor can also be neglected in the loop analysis. Finally, there is a DC gain of the uncompensated loop which is dependent on internal controller gains and the external sensing network.

A buck-boost regulator will be used as an example case. See the *Design Guide* section for compensation of all topologies. The uncompensated loop gain for a buck-boost regulator is given by the following equation:

$$T_U = T_{U0} \times \left( \frac{1 - \frac{s}{\omega_{Z1}}}{1 + \frac{s}{\omega_{P1}}} \right)$$

Where the uncompensated DC loop gain of the system is described as:

$$T_{U0} = \frac{D' \times 500V \times R_{CSH} \times R_{SNS}}{(1+D) \times R_{HSP} \times R_{LIM}} = \frac{D' \times 620V}{(1+D) \times I_{LED} \times R_{LIM}}$$

And the output pole ( $\omega_{P1}$ ) is approximated:

$$\omega_{P1} = \frac{1+D}{r_D \times C_O}$$

And the right half plane zero ( $\omega_{Z1}$ ) is:

$$\omega_{Z1} = \frac{r_D \times D^2}{D \times L1}$$

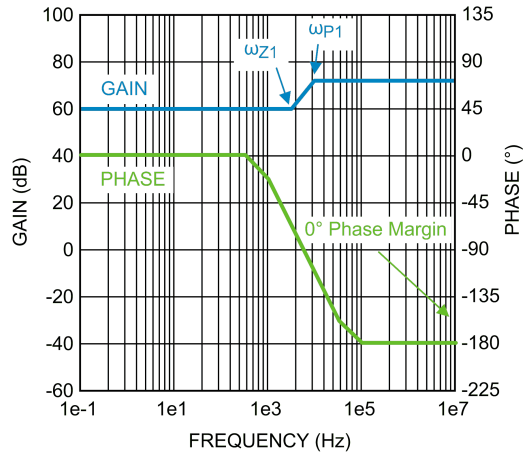

**FIGURE 7. Uncompensated Loop Gain Frequency Response**

Figure 7 shows the uncompensated loop gain in a worst-case scenario when the RHP zero is below the output pole. This occurs at high duty cycles when the regulator is trying to boost the output voltage significantly. The RHP zero adds 20dB/decade of gain while losing 45°/decade of phase which places the crossover frequency (when the gain is zero dB) extremely high because the gain only starts falling again due to the high frequency pole (not modeled or shown in figure). The phase will be below -180° at the crossover frequency which means there is no phase margin (180° + phase at crossover frequency) causing system instability. Even if the output pole is below the RHP zero, the phase will still reach -180° before the crossover frequency in most cases yielding instability.

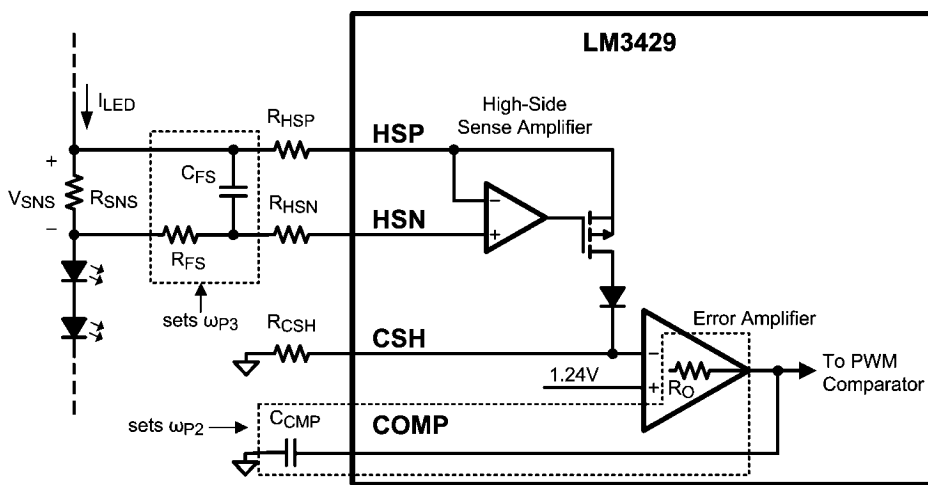

**FIGURE 8. Compensation Circuitry**

To mitigate this problem, a compensator should be designed to give adequate phase margin (above 45°) at the crossover frequency. A simple compensator using a single capacitor at the COMP pin ( $C_{COMP}$ ) will add a dominant pole to the system, which will ensure adequate phase margin if placed low enough. At high duty cycles (as shown in *Figure 7*), the RHP zero places extreme limits on the achievable bandwidth with this type of compensation. However, because an LED driver is essentially free of output transients (except catastrophic failures open or short), the dominant pole approach, even with reduced bandwidth, is usually the best approach. The dominant compensation pole ( $\omega_{P2}$ ) is determined by  $C_{COMP}$  and the output resistance ( $R_O$ ) of the error amplifier (typically 5 M $\Omega$ ):

$$\omega_{P2} = \frac{1}{5e^6 \Omega \times C_{COMP}}$$

It may also be necessary to add one final pole at least one decade above the crossover frequency to attenuate switching noise and, in some cases, provide better gain margin. This pole can be placed across  $R_{SNS}$  to filter the ESL of the sense resistor at the same time. *Figure 8* shows how the compensation is physically implemented in the system.

The high frequency pole ( $\omega_{P3}$ ) can be calculated:

$$\omega_{P3} = \frac{1}{R_{FS} \times C_{FS}}$$

The total system transfer function becomes:

$$T = T_{U0} \times \frac{\left(1 - \frac{s}{\omega_{Z1}}\right)}{\left(1 + \frac{s}{\omega_{P1}}\right) \times \left(1 + \frac{s}{\omega_{P2}}\right) \times \left(1 + \frac{s}{\omega_{P3}}\right)}$$

The resulting compensated loop gain frequency response shown in *Figure 9* indicates that the system has adequate phase margin (above 45°) if the dominant compensation pole is placed low enough, ensuring stability:

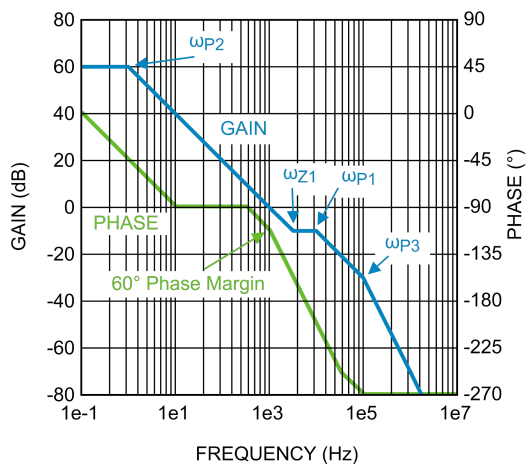

FIGURE 9. Compensated Loop Gain Frequency Response

OUTPUT OVER-VOLTAGE LOCKOUT (OVLO)

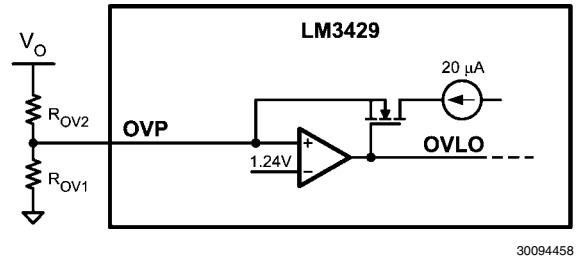

FIGURE 10. Over-Voltage Protection Circuitry

The LM3429 can be configured to detect an output (or input) over-voltage condition via the OVP pin. The pin features a precision 1.24V threshold with 20  $\mu$ A (typical) of hysteresis current as shown in *Figure 10*. When the OVLO threshold is exceeded, the GATE pin is immediately pulled low and a 20  $\mu$ A current source provides hysteresis to the lower threshold of the OVLO hysteretic band.

If the LEDs are referenced to a potential other than ground (floating), as in the buck-boost and buck configuration, the output voltage ( $V_O$ ) should be sensed and translated to ground by using a single PNP as shown in *Figure 11*.

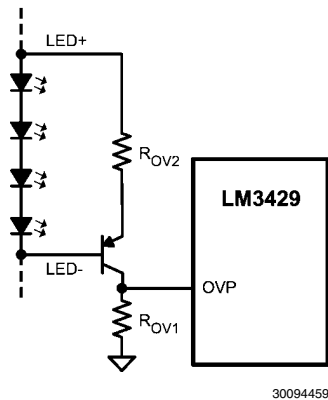

FIGURE 11. Floating Output OVP Circuitry

The over-voltage turn-off threshold ( $V_{TURN-OFF}$ ) is defined as follows:

Ground Referenced

$$V_{TURN-OFF} = 1.24V \times \left(\frac{R_{OV1} + R_{OV2}}{R_{OV1}}\right)$$

Floating

$$V_{TURN-OFF} = 1.24V \times \left(\frac{R_{OV1} + 0.5 \times R_{OV2}}{R_{OV1}}\right)$$

In the ground referenced configuration, the voltage across  $R_{OV2}$  is  $V_O - 1.24V$  whereas in the floating configuration it is  $V_O - 620\text{ mV}$  where 620 mV approximates the  $V_{BE}$  of the PNP transistor.

The over-voltage hysteresis ( $V_{HYSO}$ ) is defined as follows:

$$V_{HYSO} = 20 \mu A \times R_{OV2}$$

### INPUT UNDER-VOLTAGE LOCKOUT (UVLO)

The nDIM pin is a dual-function input that features an accurate 1.24V threshold with programmable hysteresis as shown in Figure 12. This pin functions as both the PWM dimming input for the LEDs and as a  $V_{IN}$  UVLO. When the pin voltage rises and exceeds the 1.24V threshold, 20  $\mu$ A (typical) of current is driven out of the nDIM pin into the resistor divider providing programmable hysteresis.

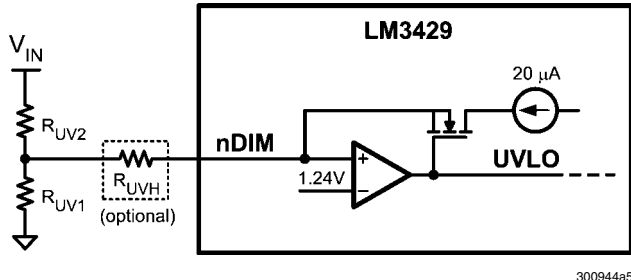

FIGURE 12. UVLO Circuit

When using the nDIM pin for UVLO and PWM dimming concurrently, the UVLO circuit can have an extra series resistor to set the hysteresis. This allows the standard resistor divider to have smaller resistor values minimizing PWM delays due to a pull-down MosFET at the nDIM pin (see *PWM Dimming* section). In general, at least 3V of hysteresis is necessary when PWM dimming if operating near the UVLO threshold.

The turn-on threshold ( $V_{TURN-ON}$ ) is defined as follows:

$$V_{TURN-ON} = 1.24V \times \left( \frac{R_{UV1} + R_{UV2}}{R_{UV1}} \right)$$

The hysteresis ( $V_{HYS}$ ) is defined as follows:

#### UVLO only

$$V_{HYS} = 20 \mu A \times R_{UV2}$$

#### PWM dimming and UVLO

$$V_{HYS} = 20 \mu A \times \left( R_{UV2} + \frac{R_{UVH} \times (R_{UV1} + R_{UV2})}{R_{UV1}} \right)$$

### PWM DIMMING

The active low nDIM pin can be driven with a PWM signal which controls the main NFET (Q1). The brightness of the LEDs can be varied by modulating the duty cycle of this signal. LED brightness is approximately proportional to the PWM signal duty cycle, so 30% duty cycle equals approximately 30% LED brightness. This function can be ignored if PWM dimming is not required by using nDIM solely as a  $V_{IN}$  UVLO input as described in the *Input Under-Voltage Lockout* section or by tying it directly to  $V_{CC}$  or  $V_{IN}$  (if less than 76VDC).

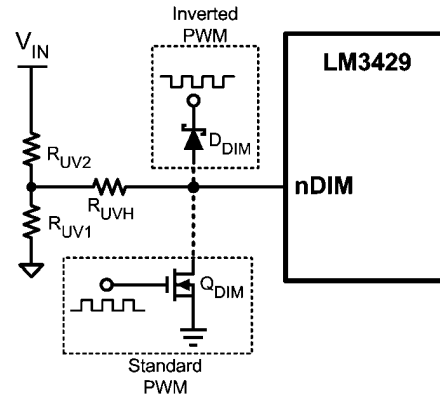

FIGURE 13. PWM Dimming Circuit

Figure 13 shows two ways the PWM signal can be applied to the nDIM pin:

1. Connect the dimming MosFET ( $Q_{DIM}$ ) with the drain to the nDIM pin and the source to GND. Apply an external logic-level PWM signal to the gate of  $Q_{DIM}$ . A pull down resistor may be necessary to properly turn off  $Q_{DIM}$  if no signal is present.
2. Connect the anode of a Schottky diode ( $D_{DIM}$ ) to the nDIM pin. Apply an external inverted logic-level PWM signal to the cathode of the same diode.

A minimum on-time must be maintained in order for PWM dimming to operate in the linear region of its transfer function. Because the controller is disabled during dimming, the PWM pulse must be long enough such that the energy intercepted from the input is greater than or equal to the energy being put into the LEDs. For boost and buck-boost regulators, the following condition must be maintained:

$$t_{PULSE} = \frac{2 \times I_{LED} \times V_O \times L1}{V_{IN}^2}$$

In the previous equation,  $t_{PULSE}$  is the length of the PWM pulse in seconds.

### STARTUP REGULATOR ( $V_{CC}$ LDO)

The LM3429 includes a high voltage, low dropout (LDO) bias regulator. When power is applied, the regulator is enabled and sources current into an external capacitor connected to the  $V_{CC}$  pin. The  $V_{CC}$  output voltage is 6.9V nominally and the supply is internally current limited to 20 mA (minimum). The recommended bypass capacitance range for the  $V_{CC}$  regulator is 2.2  $\mu$ F to 3.3  $\mu$ F. The output of the  $V_{CC}$  regulator is monitored by an internal UVLO circuit that protects the device during startup, normal operation, and shutdown from attempting to operate with insufficient supply voltage.

### THERMAL SHUTDOWN

The LM3429 includes thermal shutdown. If the die temperature reaches approximately 165°C the device will shut down (GATE pin low), until it reaches approximately 140°C where it turns on again.

## Design Considerations

This section describes the application level considerations when designing with the LM3429. For corresponding calculations, refer to the *Design Guide* section.

### INDUCTOR

The inductor (L1) is the main energy storage device in a switching regulator. Depending on the topology, energy is stored in the inductor and transferred to the load in different ways (as an example, buck-boost operation is detailed in the *Current Regulators* section). The size of the inductor, the voltage across it, and the length of the switching subinterval ( $t_{ON}$  or  $t_{OFF}$ ) determines the inductor current ripple ( $\Delta i_{L-PP}$ ). In the design process, L1 is chosen to provide a desired  $\Delta i_{L-PP}$ . For a buck regulator the inductor has a direct connection to the load, which is good for a current regulator. This requires little to no output capacitance therefore  $\Delta i_{L-PP}$  is basically equal to the LED ripple current  $\Delta i_{LED-PP}$ . However, for boost and buck-boost regulators, there is always an output capacitor which reduces  $\Delta i_{LED-PP}$ , therefore the inductor ripple can be larger than in the buck regulator case where output capacitance is minimal or completely absent.

In general,  $\Delta i_{LED-PP}$  is recommended by manufacturers to be less than 40% of the average LED current ( $I_{LED}$ ). Therefore, for the buck regulator with no output capacitance,  $\Delta i_{L-PP}$  should also be less than 40% of  $I_{LED}$ . For the boost and buck-boost topologies,  $\Delta i_{L-PP}$  can be much higher depending on the output capacitance value. However,  $\Delta i_{L-PP}$  is suggested to be less than 100% of the average inductor current ( $I_L$ ) to limit the RMS inductor current.

L1 is also suggested to have an RMS current rating at least 25% higher than the calculated minimum allowable RMS inductor current ( $I_{L-RMS}$ ).

### LED DYNAMIC RESISTANCE ( $r_D$ )

When the load is a string of LEDs, the output load resistance is the LED string dynamic resistance plus  $R_{SNS}$ . LEDs are PN junction diodes, and their dynamic resistance shifts as their forward current changes. Dividing the forward voltage of a single LED ( $V_{LED}$ ) by the forward current ( $I_{LED}$ ) leads to an incorrect calculation of the dynamic resistance of a single LED ( $r_{LED}$ ). The result can be 5 to 10 times higher than the true  $r_{LED}$  value.

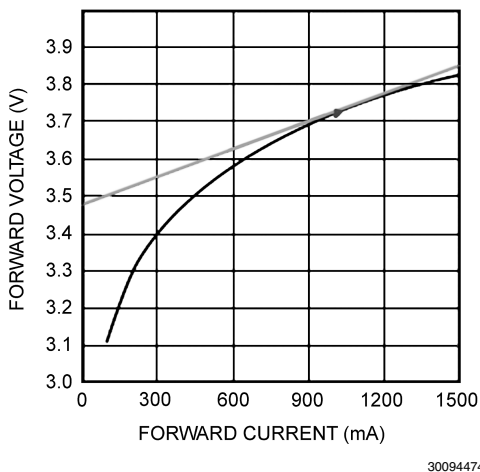

FIGURE 14. Dynamic Resistance

Obtaining  $r_{LED}$  is accomplished by referring to the manufacturer's LED I-V characteristic. It can be calculated as the slope at the nominal operating point as shown in *Figure 14*. For any application with more than 2 series LEDs,  $R_{SNS}$  can be neglected allowing  $r_D$  to be approximated as the number of LEDs multiplied by  $r_{LED}$ .

### OUTPUT CAPACITOR

For boost and buck-boost regulators, the output capacitor ( $C_O$ ) provides energy to the load when the recirculating diode (D1) is reverse biased during the first switching subinterval. An output capacitor in a buck topology will simply reduce the LED current ripple ( $\Delta i_{LED-PP}$ ) below the inductor current ripple ( $\Delta i_{L-PP}$ ). In all cases,  $C_O$  is sized to provide a desired  $\Delta i_{LED-PP}$ . As mentioned in the *Inductor* section,  $\Delta i_{LED-PP}$  is recommended by manufacturers to be less than 40% of the average LED current ( $I_{LED-PP}$ ).

$C_O$  should be carefully chosen to account for derating due to temperature and operating voltage. It must also have the necessary RMS current rating. Ceramic capacitors are the best choice due to their high ripple current rating, long lifetime, and good temperature performance. An X7R dielectric rating is suggested.

### INPUT CAPACITORS

The input capacitance ( $C_{IN}$ ) provides energy during the discontinuous portions of the switching period. For buck and buck-boost regulators,  $C_{IN}$  provides energy during  $t_{ON}$  and during  $t_{OFF}$ , the input voltage source charges up  $C_{IN}$  with the average input current ( $I_{IN}$ ). For boost regulators,  $C_{IN}$  only needs to provide the ripple current due to the direct connection to the inductor.  $C_{IN}$  is selected given the maximum input voltage ripple ( $\Delta v_{IN-PP}$ ) which can be tolerated.  $\Delta v_{IN-PP}$  is suggested to be less than 10% of the nominal input voltage ( $V_{IN}$ ).

An input capacitance at least 100% greater than the calculated  $C_{IN}$  value is recommended to account for derating due to temperature and operating voltage. It must also have the necessary RMS current rating. Ceramic capacitors are again the best choice due to their high ripple current rating, long lifetime, and good temperature performance. An X7R dielectric rating is suggested.

### N-CHANNEL MosFET (NFET)

The LM3429 requires an external NFET (Q1) as the main power MosFET for the switching regulator. Q1 is recommended to have a voltage rating at least 15% higher than the maximum transistor voltage to ensure safe operation during the ringing of the switch node. In practice, all switching regulators have some ringing at the switch node due to the diode parasitic capacitance and the lead inductance. The current rating is recommended to be at least 10% higher than the average transistor current. The power rating is then verified by calculating the power loss given the RMS transistor current and the NFET on-resistance ( $R_{DS-ON}$ ).

In general, the NFET should be chosen to minimize total gate charge ( $Q_g$ ) whenever switching frequencies are high and minimize  $R_{DS-ON}$  otherwise. This will minimize the dominant power losses in the system. Frequently, higher current NFETs in larger packages are chosen for better thermal performance.

## RE-CIRCULATING DIODE

A re-circulating diode (D1) is required to carry the inductor current during  $t_{OFF}$ . The most efficient choice for D1 is a Schottky diode due to low forward voltage drop and near-zero reverse recovery time. Similar to Q1, D1 is recommended to have a voltage rating at least 15% higher than the maximum transistor voltage to ensure safe operation during the ringing of the switch node and a current rating at least 10% higher than the average diode current. The power rating is verified by calculating the power loss through the diode. This is accomplished by checking the typical diode forward voltage from the I-V curve on the product datasheet and multiplying by the average diode current. In general, higher current diodes have a lower forward voltage and come in better performing packages minimizing both power losses and temperature rise.

## CIRCUIT LAYOUT

The performance of any switching regulator depends as much upon the layout of the PCB as the component selection. Following a few simple guidelines will maximize noise rejection and minimize the generation of EMI within the circuit.

Discontinuous currents are the most likely to generate EMI, therefore care should be taken when routing these paths. The main path for discontinuous current in the LM3429 buck regulator contains the input capacitor ( $C_{IN}$ ), the recirculating diode (D1), the N-channel MosFET (Q1), and the sense resistor ( $R_{LIM}$ ). In the LM3429 boost and buck-boost regulators, the discontinuous current flows through the output capacitor ( $C_O$ ), D1, Q1, and  $R_{LIM}$ . In either case, this loop should be kept as small as possible and the connections between all the components should be short and thick to minimize parasitic inductance. In particular, the switch node (where L1, D1 and Q1 connect) should be just large enough to connect the components. To minimize excessive heating, large copper pours can be placed adjacent to the short current path of the switch node.

The RCT, COMP, CSH, IS, HSP and HSN pins are all high-impedance inputs which couple external noise easily, therefore the loops containing these nodes should be minimized whenever possible.

In some applications the LED or LED array can be far away (several inches or more) from the LM3429, or on a separate PCB connected by a wiring harness. When an output capacitor is used and the LED array is large or separated from the rest of the regulator, the output capacitor should be placed close to the LEDs to reduce the effects of parasitic inductance on the AC impedance of the capacitor.

# Basic Topology Schematics

## BOOST REGULATOR ( $V_{IN} < V_O$ )

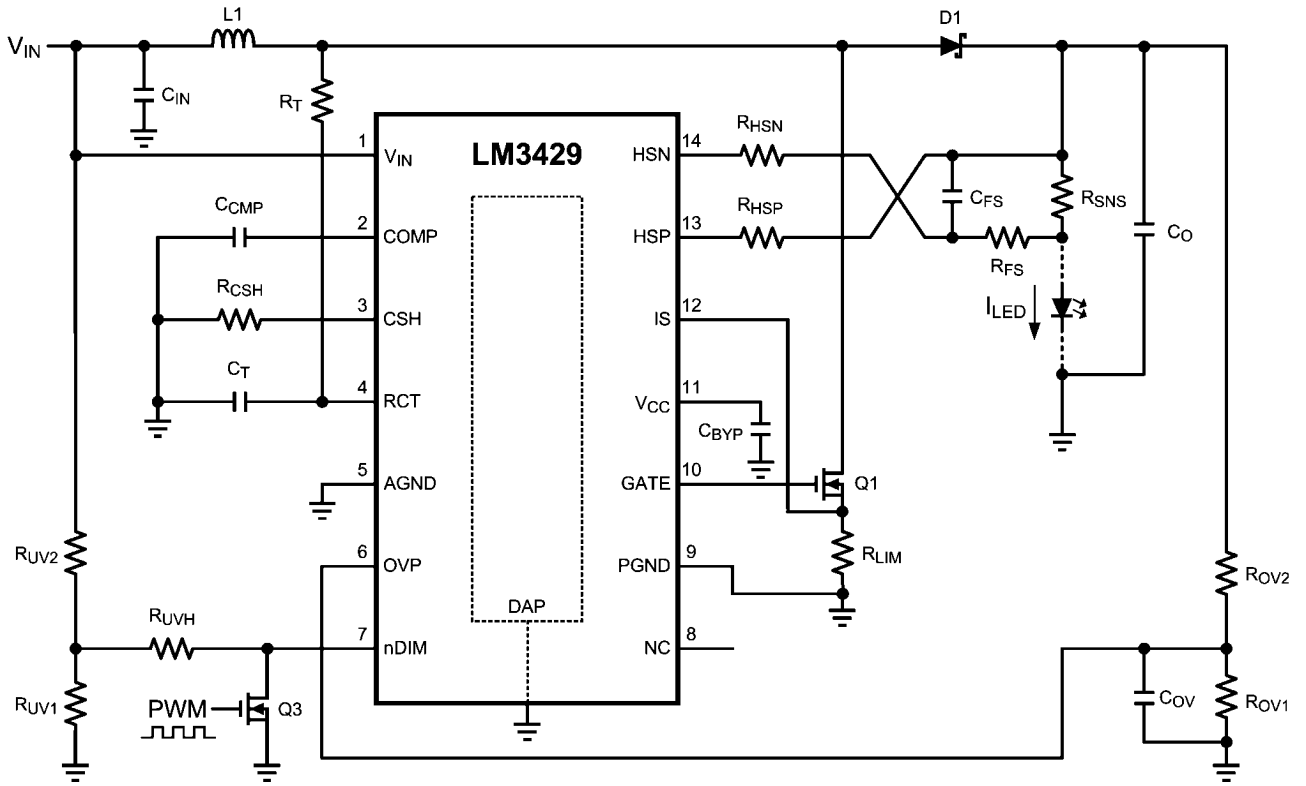

30094422

## BUCK REGULATOR ( $V_{IN} > V_O$ )

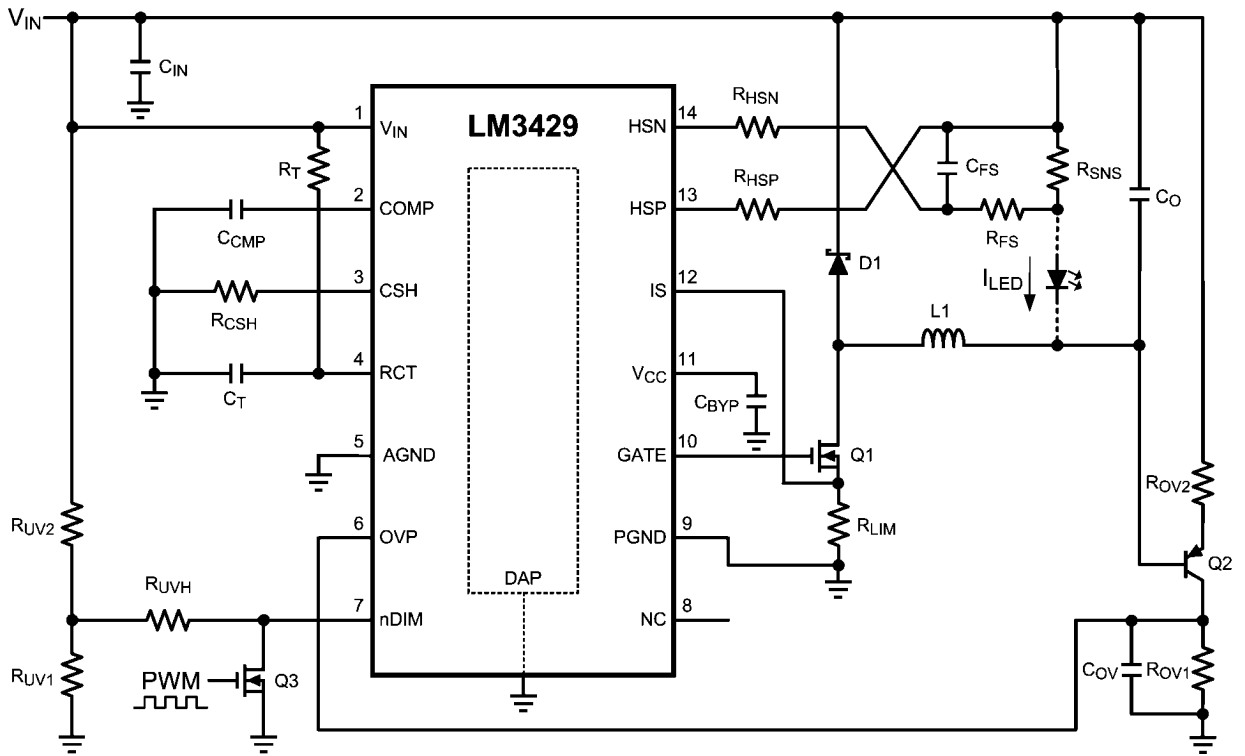

30094451



# BUCK-BOOST REGULATOR

LM3429

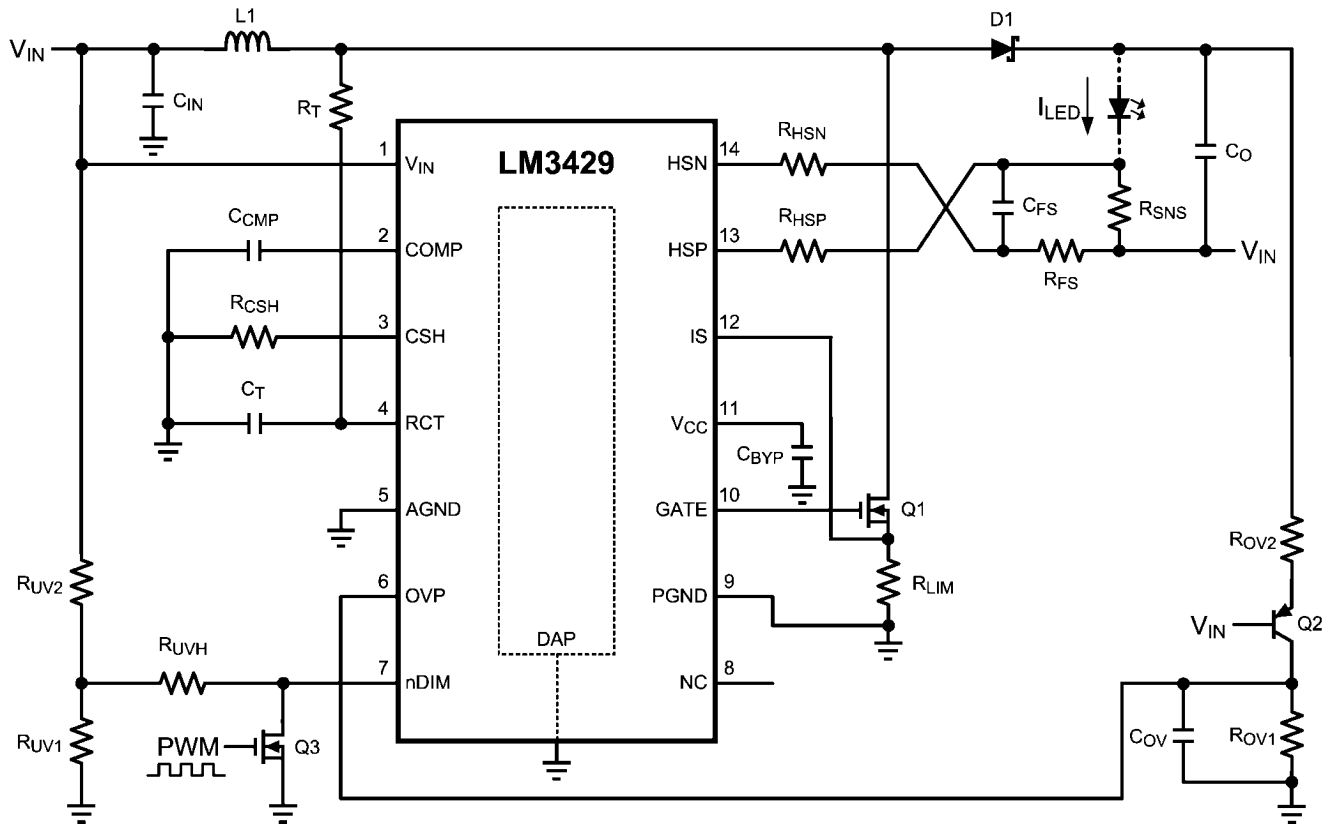

30094450

## Design Guide

Refer to *Basic Topology Schematics* section.

### SPECIFICATIONS

Number of series LEDs: N

Single LED forward voltage:  $V_{LED}$

Single LED dynamic resistance:  $r_{LED}$

Nominal input voltage:  $V_{IN}$

Input voltage range:  $V_{IN-MAX}$ ,  $V_{IN-MIN}$

Switching frequency:  $f_{SW}$

Current sense voltage:  $V_{SNS}$

Average LED current:  $I_{LED}$

Inductor current ripple:  $\Delta i_{L-PP}$

LED current ripple:  $\Delta i_{LED-PP}$

Peak current limit:  $I_{LIM}$

Input voltage ripple:  $\Delta v_{IN-PP}$

Output OVLO characteristics:  $V_{TURN-OFF}$ ,  $V_{HYSO}$

Input UVLO characteristics:  $V_{TURN-ON}$ ,  $V_{HYS}$

### 1. OPERATING POINT

Given the number of series LEDs (N), the forward voltage ( $V_{LED}$ ) and dynamic resistance ( $r_{LED}$ ) for a single LED, solve for the nominal output voltage ( $V_O$ ) and the nominal LED string dynamic resistance ( $r_D$ ):

$$V_O = N \times V_{LED}$$

$$r_D = N \times r_{LED}$$

Solve for the ideal nominal duty cycle (D):

#### Buck

$$D = \frac{V_O}{V_{IN}}$$

#### Boost

$$D = \frac{V_O - V_{IN}}{V_O}$$

#### Buck-boost

$$D = \frac{V_O}{V_O + V_{IN}}$$

Using the same equations, find the minimum duty cycle ( $D_{MIN}$ ) using maximum input voltage ( $V_{IN-MAX}$ ) and the maximum duty cycle ( $D_{MAX}$ ) using the minimum input voltage ( $V_{IN-MIN}$ ). Also, remember that  $D' = 1 - D$ .

### 2. SWITCHING FREQUENCY

Set the switching frequency ( $f_{SW}$ ) by assuming a  $C_T$  value of 1 nF and solving for  $R_T$ :

#### Buck (Constant Ripple vs. $V_{IN}$ )

$$R_T = \frac{25 \times (V_{IN} - V_O)}{f_{SW} \times C_T \times V_{IN}}$$

#### Buck (Constant Ripple vs. $V_O$ )

$$R_T = \frac{25 \times (V_{IN} \times V_O - V_O^2)}{f_{SW} \times C_T \times V_{IN}^2}$$

#### Boost and Buck-boost

$$R_T = \frac{25}{f_{SW} \times C_T}$$

### 3. AVERAGE LED CURRENT

For all topologies, set the average LED current ( $I_{LED}$ ) knowing the desired current sense voltage ( $V_{SNS}$ ) and solving for  $R_{SNS}$ :

$$R_{SNS} = \frac{V_{SNS}}{I_{LED}}$$

If the calculated  $R_{SNS}$  is too far from a desired standard value, then  $V_{SNS}$  will have to be adjusted to obtain a standard value. Setup the suggested signal current of 100  $\mu$ A by assuming  $R_{CSH} = 12.4 \text{ k}\Omega$  and solving for  $R_{HSP}$ :

$$R_{HSP} = \frac{I_{LED} \times R_{CSH} \times R_{SNS}}{1.24V}$$

If the calculated  $R_{HSP}$  is too far from a desired standard value, then  $R_{CSH}$  can be adjusted to obtain a standard value.

### 4. INDUCTOR RIPPLE CURRENT

Set the nominal inductor ripple current ( $\Delta i_{L-PP}$ ) by solving for the appropriate inductor (L1):

#### Buck

$$L1 = \frac{(V_{IN} - V_O) \times D}{\Delta i_{L-PP} \times f_{SW}}$$

#### Boost and Buck-boost

$$L1 = \frac{V_{IN} \times D}{\Delta i_{L-PP} \times f_{SW}}$$

To set the worst case inductor ripple current, use  $V_{IN-MAX}$  and  $D_{MIN}$  when solving for L1.

The minimum allowable inductor RMS current rating ( $I_{L-RMS}$ ) can be calculated as:

#### Buck

$$I_{L-RMS} = I_{LED} \times \sqrt{1 + \frac{1}{12} \times \left( \frac{\Delta i_{L-PP}}{I_{LED}} \right)^2}$$

#### Boost and Buck-boost

$$I_{L-RMS} = \frac{I_{LED}}{D'} \times \sqrt{1 + \frac{1}{12} \times \left( \frac{\Delta i_{L-PP} \times D'}{I_{LED}} \right)^2}$$

## 5. LED RIPPLE CURRENT

Set the nominal LED ripple current ( $\Delta i_{LED-PP}$ ), by solving for the output capacitance ( $C_O$ ):

### Buck

$$C_O = \frac{\Delta i_{L-PP}}{8 \times f_{SW} \times r_D \times \Delta i_{LED-PP}}$$

### Boost and Buck-boost

$$C_O = \frac{I_{LED} \times D}{r_D \times \Delta i_{LED-PP} \times f_{SW}}$$

To set the worst case LED ripple current, use  $D_{MAX}$  when solving for  $C_O$ .

The minimum allowable RMS output capacitor current rating ( $I_{CO-RMS}$ ) can be approximated:

### Buck

$$I_{CO-RMS} = \frac{\Delta i_{LED-PP}}{\sqrt{12}}$$

### Boost and Buck-boost

$$I_{CO-RMS} = I_{LED} \times \sqrt{\frac{D_{MAX}}{1-D_{MAX}}}$$

## 6. PEAK CURRENT LIMIT

Set the peak current limit ( $I_{LIM}$ ) by solving for the transistor path sense resistor ( $R_{LIM}$ ):

$$R_{LIM} = \frac{245 \text{ mV}}{I_{LIM}}$$

## 7. LOOP COMPENSATION

Using a simple first order peak current mode control model, neglecting any output capacitor ESR dynamics, the necessary loop compensation can be determined.

First, the uncompensated loop gain ( $T_U$ ) of the regulator can be approximated:

### Buck

$$T_U = T_{U0} \times \frac{1}{\left(1 + \frac{s}{\omega_{P1}}\right)}$$

### Boost and Buck-boost

$$T_U = T_{U0} \times \frac{\left(1 - \frac{s}{\omega_{Z1}}\right)}{\left(1 + \frac{s}{\omega_{P1}}\right)}$$

Where the pole ( $\omega_{P1}$ ) is approximated:

### Buck

$$\omega_{P1} = \frac{1}{r_D \times C_O}$$

### Boost

$$\omega_{P1} = \frac{2}{r_D \times C_O}$$

### Buck-boost

$$\omega_{P1} = \frac{1+D}{r_D \times C_O}$$

And the RHP zero ( $\omega_{Z1}$ ) is approximated:

### Boost

$$\omega_{Z1} = \frac{r_D \times D^2}{L1}$$

### Buck-boost

$$\omega_{Z1} = \frac{r_D \times D^2}{D \times L1}$$

And the uncompensated DC loop gain ( $T_{U0}$ ) is approximated:

### Buck

$$T_{U0} = \frac{500V \times R_{CSH} \times R_{SNS}}{R_{HSP} \times R_{LIM}} = \frac{620V}{I_{LED} \times R_{LIM}}$$

### Boost

$$T_{U0} = \frac{D' \times 500V \times R_{CSH} \times R_{SNS}}{2 \times R_{HSP} \times R_{LIM}} = \frac{D' \times 310V}{I_{LED} \times R_{LIM}}$$

### Buck-boost

$$T_{U0} = \frac{D' \times 500V \times R_{CSH} \times R_{SNS}}{(1+D) \times R_{HSP} \times R_{LIM}} = \frac{D' \times 620V}{(1+D) \times I_{LED} \times R_{LIM}}$$

For all topologies, the primary method of compensation is to place a low frequency dominant pole ( $\omega_{P2}$ ) which will ensure that there is ample phase margin at the crossover frequency. This is accomplished by placing a capacitor ( $C_{CMP}$ ) from the COMP pin to GND, which is calculated according to the lower value of the pole and the RHP zero of the system (shown as a minimizing function):

$$\omega_{P2} = \frac{\min(\omega_{P1}, \omega_{Z1})}{5 \times T_{U0}}$$

$$C_{CMP} = \frac{1}{\omega_{P2} \times 5e^6}$$

If analog dimming is used,  $C_{CMP}$  should be approximately 4x larger to maintain stability as the LEDs are dimmed to zero.

A high frequency compensation pole ( $\omega_{p3}$ ) can be used to attenuate switching noise and provide better gain margin. Assuming  $R_{FS} = 10\Omega$ ,  $C_{FS}$  is calculated according to the higher value of the pole and the RHP zero of the system (shown as a maximizing function):

$$\omega_{p3} = \max(\omega_{p1}, \omega_{z1}) \times 10$$

$$C_{FS} = \frac{1}{10 \times \omega_{p3}}$$

The total system loop gain (T) can then be written as:

#### Buck

$$T = T_{U0} \times \frac{1}{\left(1 + \frac{s}{\omega_{p1}}\right) \times \left(1 + \frac{s}{\omega_{p2}}\right) \times \left(1 + \frac{s}{\omega_{p3}}\right)}$$

#### Boost and Buck-boost

$$T = T_{U0} \times \frac{\left(1 - \frac{s}{\omega_{z1}}\right)}{\left(1 + \frac{s}{\omega_{p1}}\right) \times \left(1 + \frac{s}{\omega_{p2}}\right) \times \left(1 + \frac{s}{\omega_{p3}}\right)}$$

### 8. INPUT CAPACITANCE

Set the nominal input voltage ripple ( $\Delta V_{IN-PP}$ ) by solving for the required capacitance ( $C_{IN}$ ):

#### Buck

$$C_{IN} = \frac{I_{LED} \times (1 - D) \times D}{\Delta V_{IN-PP} \times f_{SW}}$$

#### Boost

$$C_{IN} = \frac{\Delta i_{L-PP}}{8 \times \Delta V_{IN-PP} \times f_{SW}}$$

#### Buck-boost

$$C_{IN} = \frac{I_{LED} \times D}{\Delta V_{IN-PP} \times f_{SW}}$$

Use  $D_{MAX}$  to set the worst case input voltage ripple, when solving for  $C_{IN}$  in a buck-boost regulator and  $D_{MID} = 0.5$  when solving for  $C_{IN}$  in a buck regulator.

The minimum allowable RMS input current rating ( $I_{CIN-RMS}$ ) can be approximated:

#### Buck

$$I_{CIN-RMS} = I_{LED} \times \sqrt{D_{MID} \times (1 - D_{MID})}$$

#### Boost

$$I_{CIN-RMS} = \frac{\Delta i_{L-PP}}{\sqrt{12}}$$

#### Buck-boost

$$I_{CIN-RMS} = I_{LED} \times \sqrt{\frac{D_{MAX}}{1 - D_{MAX}}}$$

### 9. NFET

The NFET voltage rating should be at least 15% higher than the maximum NFET drain-to-source voltage ( $V_{T-MAX}$ ):

#### Buck

$$V_{T-MAX} = V_{IN-MAX}$$

#### Boost

$$V_{T-MAX} = V_O$$

#### Buck-boost

$$V_{T-MAX} = V_{IN-MAX} + V_O$$

The current rating should be at least 10% higher than the maximum average NFET current ( $I_{T-MAX}$ ):

#### Buck

$$I_{T-MAX} = D_{MAX} \times I_{LED}$$

#### Boost and Buck-boost

$$I_{T-MAX} = \frac{D_{MAX}}{1 - D_{MAX}} \times I_{LED}$$

Approximate the nominal RMS transistor current ( $I_{T-RMS}$ ):

#### Buck

$$I_{T-RMS} = I_{LED} \times \sqrt{D}$$

#### Boost and Buck-boost

$$I_{T-RMS} = \frac{I_{LED}}{D'} \times \sqrt{D}$$

Given an NFET with on-resistance ( $R_{DS-ON}$ ), solve for the nominal power dissipation ( $P_T$ ):

$$P_T = I_{T-RMS}^2 \times R_{DS-ON}$$

### 10. DIODE

The Schottky diode voltage rating should be at least 15% higher than the maximum blocking voltage ( $V_{RD-MAX}$ ):

#### Buck

$$V_{RD-MAX} = V_{IN-MAX}$$

#### Boost

$$V_{RD-MAX} = V_O$$

#### Buck-boost

$$V_{RD-MAX} = V_{IN-MAX} + V_O$$

The current rating should be at least 10% higher than the maximum average diode current ( $I_{D-MAX}$ ):

#### Buck

$$I_{D-MAX} = (1 - D_{MIN}) \times I_{LED}$$

#### Boost and Buck-boost

$$I_{D-MAX} = I_{LED}$$

Replace  $D_{MAX}$  with  $D$  in the  $I_{D-MAX}$  equation to solve for the average diode current ( $I_D$ ). Given a diode with forward voltage ( $V_{FD}$ ), solve for the nominal power dissipation ( $P_D$ ):

$$P_D = I_D \times V_{FD}$$

#### 11. OUTPUT OVLO

For boost and buck-boost regulators, output OVLO is programmed with the turn-off threshold voltage ( $V_{TURN-OFF}$ ) and the desired hysteresis ( $V_{HYSO}$ ). To set  $V_{HYSO}$ , solve for  $R_{OV2}$ :

$$R_{OV2} = \frac{V_{HYSO}}{20 \mu A}$$

To set  $V_{TURN-OFF}$ , solve for  $R_{OV1}$ :

#### Boost

$$R_{OV1} = \frac{1.24V \times R_{OV2}}{V_{TURN-OFF} - 1.24V}$$

#### Buck-boost

$$R_{OV1} = \frac{1.24V \times R_{OV2}}{V_{TURN-OFF} - 620 \text{ mV}}$$

A small filter capacitor ( $C_{OVP} = 47 \text{ nF}$ ) should be added from the OVP pin to ground to reduce coupled switching noise.

#### 12. INPUT UVLO

For all topologies, input UVLO is programmed with the turn-on threshold voltage ( $V_{TURN-ON}$ ) and the desired hysteresis ( $V_{HYS}$ ).

**Method #1:** If no PWM dimming is required, a two resistor network can be used. To set  $V_{HYS}$ , solve for  $R_{UV2}$ :

$$R_{UV2} = \frac{V_{HYS}}{20 \mu A}$$

To set  $V_{TURN-ON}$ , solve for  $R_{UV1}$ :

$$R_{UV1} = \frac{1.24V \times R_{UV2}}{V_{TURN-ON} - 1.24V}$$

**Method #2:** If PWM dimming is required, a three resistor network is suggested. To set  $V_{TURN-ON}$ , assume  $R_{UV2} = 10 \text{ k}\Omega$  and solve for  $R_{UV1}$  as in Method #1. To set  $V_{HYS}$ , solve for  $R_{UVH}$ :

$$R_{UVH} = \frac{R_{UV1} \times (V_{HYS} - 20 \mu A \times R_{UV2})}{20 \mu A \times (R_{UV1} + R_{UV2})}$$

#### 13. PWM DIMMING METHOD

PWM dimming can be performed several ways:

**Method #1:** Connect the dimming MosFET ( $Q_3$ ) with the drain to the nDIM pin and the source to GND. Apply an external PWM signal to the gate of  $Q_{DIM}$ . A pull down resistor may be necessary to properly turn off  $Q_3$ .

**Method #2:** Connect the anode of a Schottky diode to the nDIM pin. Apply an external inverted PWM signal to the cathode of the same diode.

#### 14. ANALOG DIMMING METHOD

Analog dimming can be performed several ways:

**Method #1:** Place a potentiometer in series with the  $R_{CSH}$  resistor to dim the LED current from the nominal  $I_{LED}$  to near zero.

**Method #2:** Connect a controlled current source as detailed in the *Analog Dimming* section to the CSH pin. Increasing the current sourced into the CSH node will decrease the LEDs from the nominal  $I_{LED}$  to zero current.

## Design Example #1

### BUCK-BOOST APPLICATION - 6 LEDs at 1A

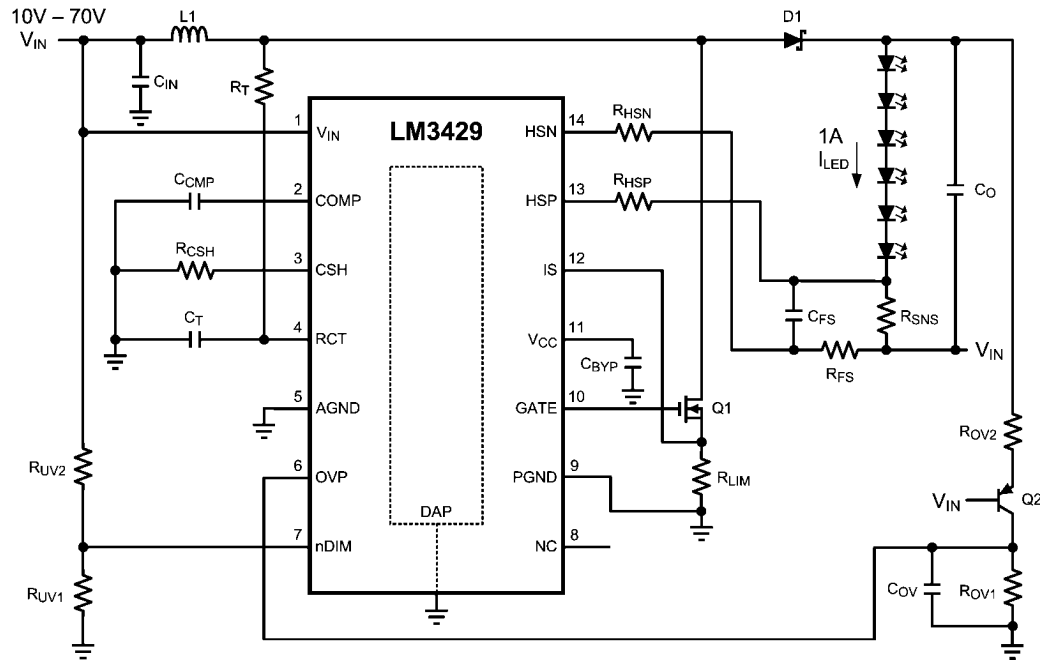

30094411

#### SPECIFICATIONS

- $N = 6$
- $V_{LED} = 3.5V$
- $r_{LED} = 325\text{ m}\Omega$
- $V_{IN} = 24V$
- $V_{IN-MIN} = 10V$
- $V_{IN-MAX} = 70V$
- $f_{SW} = 700\text{ kHz}$
- $V_{SNS} = 100\text{ mV}$
- $I_{LED} = 1A$
- $\Delta i_{L-PP} = 500\text{ mA}$
- $\Delta i_{LED-PP} = 50\text{ mA}$
- $\Delta V_{IN-PP} = 1V$
- $I_{LIM} = 6A$
- $V_{TURN-ON} = 10V$
- $V_{HYS} = 3V$
- $V_{TURN-OFF} = 40V$
- $V_{HYSO} = 10V$

#### 1. OPERATING POINT

Solve for  $V_O$  and  $r_D$ :

$$V_O = N \times V_{LED} = 6 \times 3.5V = 21V$$

$$r_D = N \times r_{LED} = 6 \times 325\text{ m}\Omega = 1.95\Omega$$

Solve for  $D$ ,  $D'$ ,  $D_{MAX}$ , and  $D_{MIN}$ :

$$D = \frac{V_O}{V_O + V_{IN}} = \frac{21V}{21V + 24V} = 0.467$$

$$D' = 1 - D = 1 - 0.467 = 0.533$$

$$D_{MIN} = \frac{V_O}{V_O + V_{IN-MAX}} = \frac{21V}{21V + 70V} = 0.231$$

$$D_{MAX} = \frac{V_O}{V_O + V_{IN-MIN}} = \frac{21V}{21V + 10V} = 0.677$$

#### 2. SWITCHING FREQUENCY

Assume  $C_T = 1\text{ nF}$  and solve for  $R_T$ :

$$R_T = \frac{25}{f_{SW} \times C_T} = \frac{25}{700\text{ kHz} \times 1\text{ nF}} = 35.7\text{ k}\Omega$$

The closest standard resistor is actually  $35.7\text{ k}\Omega$  therefore the  $f_{SW}$  is:

$$f_{SW} = \frac{25}{R_T \times C_T} = \frac{25}{35.7\text{ k}\Omega \times 1\text{ nF}} = 700\text{ kHz}$$

The chosen components from step 2 are:

$C_T = 1\text{ nF}$ $R_T = 35.7\text{ k}\Omega$
--

### 3. AVERAGE LED CURRENT

Solve for  $R_{SNS}$ :

$$R_{SNS} = \frac{V_{SNS}}{I_{LED}} = \frac{100 \text{ mV}}{1 \text{ A}} = 0.1 \Omega$$

Assume  $R_{CSH} = 12.4 \text{ k}\Omega$  and solve for  $R_{HSP}$ :

$$R_{HSP} = \frac{I_{LED} \times R_{CSH} \times R_{SNS}}{1.24 \text{ V}} = \frac{1 \text{ A} \times 12.4 \text{ k}\Omega \times 0.1 \Omega}{1.24 \text{ V}} = 1.0 \text{ k}\Omega$$

The closest standard resistor for  $R_{SNS}$  is actually  $0.1 \Omega$  and for  $R_{HSP}$  is actually  $1 \text{ k}\Omega$  therefore  $I_{LED}$  is:

$$I_{LED} = \frac{1.24 \text{ V} \times R_{HSP}}{R_{SNS} \times R_{CSH}} = \frac{1.24 \text{ V} \times 1.0 \text{ k}\Omega}{0.1 \Omega \times 12.4 \text{ k}\Omega} = 1.0 \text{ A}$$

The chosen components from step 3 are:

$R_{SNS} = 0.1 \Omega$ $R_{CSH} = 12.4 \text{ k}\Omega$ $R_{HSP} = R_{HSN} = 1 \text{ k}\Omega$
---

### 4. INDUCTOR RIPPLE CURRENT

Solve for L1:

$$L1 = \frac{V_{IN} \times D}{\Delta i_{L-PP} \times f_{SW}} = \frac{24 \text{ V} \times 0.467}{500 \text{ mA} \times 700 \text{ kHz}} = 32 \mu\text{H}$$

The closest standard inductor is  $33 \mu\text{H}$  therefore the actual  $\Delta i_{L-PP}$  is:

$$\Delta i_{L-PP} = \frac{V_{IN} \times D}{L1 \times f_{SW}} = \frac{24 \text{ V} \times 0.467}{33 \mu\text{H} \times 700 \text{ kHz}} = 485 \text{ mA}$$

Determine minimum allowable RMS current rating:

$$I_{L-RMS} = \frac{I_{LED}}{D'} \times \sqrt{1 + \frac{1}{12} \times \left( \frac{\Delta i_{L-PP} \times D'}{I_{LED}} \right)^2}$$

$$I_{L-RMS} = \frac{1 \text{ A}}{0.533} \times \sqrt{1 + \frac{1}{12} \times \left( \frac{485 \text{ mA} \times 0.533}{1 \text{ A}} \right)^2}$$

$$I_{L-RMS} = 1.88 \text{ A}$$

The chosen component from step 4 is:

$L1 = 33 \mu\text{H}$
-----------------------

### 5. OUTPUT CAPACITANCE

Solve for  $C_O$ :

$$C_O = \frac{I_{LED} \times D}{r_D \times \Delta i_{LED-PP} \times f_{SW}}$$

$$C_O = \frac{1 \text{ A} \times 0.467}{1.95 \Omega \times 50 \text{ mA} \times 700 \text{ kHz}} = 6.84 \mu\text{F}$$

The closest standard capacitor is  $6.8 \mu\text{F}$  therefore the actual  $\Delta i_{LED-PP}$  is:

$$\Delta i_{LED-PP} = \frac{I_{LED} \times D}{r_D \times C_O \times f_{SW}}$$

$$\Delta i_{LED-PP} = \frac{1 \text{ A} \times 0.467}{1.95 \Omega \times 6.8 \mu\text{F} \times 700 \text{ kHz}} = 50 \text{ mA}$$

Determine minimum allowable RMS current rating:

$$I_{CO-RMS} = I_{LED} \times \sqrt{\frac{D_{MAX}}{1 - D_{MAX}}} = 1 \text{ A} \times \sqrt{\frac{0.677}{1 - 0.677}} = 1.45 \text{ A}$$

The chosen components from step 5 are:

$C_O = 6.8 \mu\text{F}$
-------------------------

### 6. PEAK CURRENT LIMIT

Solve for  $R_{LIM}$ :

$$R_{LIM} = \frac{245 \text{ mV}}{I_{LIM}} = \frac{245 \text{ mV}}{6 \text{ A}} = 0.041 \Omega$$

The closest standard resistor is  $0.04 \Omega$  therefore  $I_{LIM}$  is:

$$I_{LIM} = \frac{245 \text{ mV}}{R_{LIM}} = \frac{245 \text{ mV}}{0.04 \Omega} = 6.13 \text{ A}$$

The chosen component from step 6 is:

$R_{LIM} = 0.04 \Omega$
-------------------------

### 7. LOOP COMPENSATION

$\omega_{P1}$  is approximated:

$$\omega_{P1} = \frac{1 + D}{r_D \times C_O} = \frac{1.467}{1.95 \Omega \times 6.7 \mu\text{F}} = 110 \text{ k} \frac{\text{rad}}{\text{sec}}$$

$\omega_{Z1}$  is approximated:

$$\omega_{Z1} = \frac{r_D \times D'^2}{D \times L1} = \frac{1.95 \Omega \times 0.533^2}{0.467 \times 33 \mu\text{H}} = 37 \text{ k} \frac{\text{rad}}{\text{sec}}$$

$T_{U0}$  is approximated:

$$T_{U0} = \frac{D' \times 620V}{(1+D) \times I_{LED} \times R_{LIM}} = \frac{0.533 \times 620V}{1.467 \times 1A \times 0.04\Omega} = 5630$$

To ensure stability, calculate  $\omega_{P2}$ :

$$\omega_{P2} = \frac{\min(\omega_{P1}, \omega_{Z1})}{5 \times T_{U0}} = \frac{\omega_{Z1}}{5 \times 5630} = \frac{37k \frac{\text{rad}}{\text{sec}}}{5 \times 5630} = 1.173 \frac{\text{rad}}{\text{sec}}$$

Solve for  $C_{COMP}$ :

$$C_{COMP} = \frac{1}{\omega_{P2} \times 5e^6\Omega} = \frac{1}{1.173 \frac{\text{rad}}{\text{sec}} \times 5e^6\Omega} = 0.17 \mu\text{F}$$

To attenuate switching noise, calculate  $\omega_{P3}$ :

$$\omega_{P3} = \max(\omega_{P1}, \omega_{Z1}) \times 10 = \omega_{P1} \times 10$$

$$\omega_{P3} = 110k \frac{\text{rad}}{\text{sec}} \times 10 = 1.1M \frac{\text{rad}}{\text{sec}}$$

Assume  $R_{FS} = 10\Omega$  and solve for  $C_{FS}$ :

$$C_{FS} = \frac{1}{10\Omega \times \omega_{P3}} = \frac{1}{10\Omega \times 1.1M \frac{\text{rad}}{\text{sec}}} = 0.091 \mu\text{F}$$

The chosen components from step 7 are:

$$\begin{aligned} C_{COMP} &= 0.22 \mu\text{F} \\ R_{FS} &= 10\Omega \\ C_{FS} &= 0.1 \mu\text{F} \end{aligned}$$

## 8. INPUT CAPACITANCE

Solve for the minimum  $C_{IN}$ :

$$C_{IN} = \frac{I_{LED} \times D}{\Delta V_{IN-PP} \times f_{SW}} = \frac{1A \times 0.467}{100 \text{mV} \times 700 \text{kHz}} = 6.66 \mu\text{F}$$

To minimize power supply interaction a 200% larger capacitance of approximately 14  $\mu\text{F}$  is used, therefore the actual  $\Delta V_{IN-PP}$  is much lower. Since high voltage ceramic capacitor selection is limited, three 4.7  $\mu\text{F}$  X7R capacitors are chosen.

Determine minimum allowable RMS current rating:

$$I_{IN-RMS} = I_{LED} \times \sqrt{\frac{D_{MAX}}{1-D_{MAX}}} = 1A \times \sqrt{\frac{0.677}{1-0.677}} = 1.45A$$

The chosen components from step 8 are:

$$C_{IN} = 3 \times 4.7 \mu\text{F}$$

## 9. NFET

Determine minimum Q1 voltage rating and current rating:

$$V_{T-MAX} = V_{IN-MAX} + V_O = 70V + 21V = 91V$$

$$I_{T-MAX} = \frac{0.677}{1-0.677} \times 1A = 2.1A$$

A 100V NFET is chosen with a current rating of 32A due to the low  $R_{DS-ON} = 50 \text{m}\Omega$ . Determine  $I_{T-RMS}$  and  $P_T$ :

$$I_{T-RMS} = \frac{I_{LED}}{D'} \times \sqrt{D} = \frac{1A}{0.533} \times \sqrt{0.467} = 1.28A$$

$$P_T = I_{T-RMS}^2 \times R_{DS-ON} = 1.28A^2 \times 50 \text{m}\Omega = 82 \text{mW}$$

The chosen component from step 9 is:

$$Q1 \rightarrow 32A, 100V, \text{ DPAK}$$

## 10. DIODE

Determine minimum D1 voltage rating and current rating:

$$V_{RD-MAX} = V_{IN-MAX} + V_O = 70V + 21V = 91V$$

$$I_{D-MAX} = I_{LED} = 1A$$

A 100V diode is chosen with a current rating of 12A and  $V_D = 600 \text{mV}$ . Determine  $P_D$ :

$$P_D = I_D \times V_{FD} = 1A \times 600 \text{mV} = 600 \text{mW}$$

The chosen component from step 10 is:

$$D1 \rightarrow 12A, 100V, \text{ DPAK}$$

## 11. INPUT UVLO

Solve for  $R_{UV2}$ :

$$R_{UV2} = \frac{V_{HYS}}{20 \mu\text{A}} = \frac{3V}{20 \mu\text{A}} = 150 \text{k}\Omega$$

The closest standard resistor is 150  $\text{k}\Omega$  therefore  $V_{HYS}$  is:

$$V_{HYS} = R_{UV2} \times 20 \mu\text{A} = 150 \text{k}\Omega \times 20 \mu\text{A} = 3V$$

Solve for  $R_{UV1}$ :

$$R_{UV1} = \frac{1.24V \times R_{UV2}}{V_{TURN-ON} - 1.24V} = \frac{1.24V \times 150 \text{k}\Omega}{10V - 1.24V} = 21.2 \text{k}\Omega$$



The closest standard resistor is 21 k $\Omega$  making  $V_{\text{TURN-ON}}$ :

$$V_{\text{TURN-ON}} = \frac{1.24\text{V} \times (R_{\text{UV1}} + R_{\text{UV2}})}{R_{\text{UV1}}}$$

$$V_{\text{TURN-ON}} = \frac{1.24\text{V} \times (21\text{ k}\Omega + 150\text{ k}\Omega)}{21\text{ k}\Omega} = 10.1\text{V}$$

The chosen components from step 11 are:

$$R_{\text{UV1}} = 21\text{ k}\Omega$$

$$R_{\text{UV2}} = 150\text{ k}\Omega$$

## 12. OUTPUT OVLO

Solve for  $R_{\text{OV2}}$ :

$$R_{\text{OV2}} = \frac{V_{\text{HYSO}}}{20\text{ }\mu\text{A}} = \frac{10\text{V}}{20\text{ }\mu\text{A}} = 500\text{ k}\Omega$$

The closest standard resistor is 499 k $\Omega$  therefore  $V_{\text{HYSO}}$  is:

$$V_{\text{HYSO}} = R_{\text{OV2}} \times 20\text{ }\mu\text{A} = 499\text{ k}\Omega \times 20\text{ }\mu\text{A} = 9.98\text{V}$$

Solve for  $R_{\text{OV1}}$ :

$$R_{\text{OV1}} = \frac{1.24\text{V} \times R_{\text{OV2}}}{V_{\text{TURN-OFF}} - 1.24\text{V}} = \frac{1.24\text{V} \times 499\text{ k}\Omega}{40\text{V} - 1.24\text{V}} = 16\text{ k}\Omega$$

The closest standard resistor is 15.8 k $\Omega$  making  $V_{\text{TURN-OFF}}$ :

$$V_{\text{TURN-OFF}} = \frac{1.24\text{V} \times (R_{\text{OV1}} + R_{\text{OV2}})}{R_{\text{OV1}}}$$

$$V_{\text{TURN-OFF}} = \frac{1.24\text{V} \times (15.8\text{ k}\Omega + 499\text{ k}\Omega)}{15.8\text{ k}\Omega} = 40.4\text{V}$$

The chosen components from step 12 are:

$$R_{\text{OV1}} = 15.8\text{ k}\Omega$$

$$R_{\text{OV2}} = 499\text{ k}\Omega$$

## Design #1 Bill of Materials

Qty	Part ID	Part Value	Manufacturer	Part Number
1	LM3429	Boost controller	NSC	LM3429MH
1	C <sub>COMP</sub>	0.22 $\mu\text{F}$ X7R 10% 25V	MURATA	GRM21BR71E224KA01L
1	C <sub>F</sub>	2.2 $\mu\text{F}$ X7R 10% 16V	MURATA	GRM21BR71C225KA12L
1	C <sub>FS</sub>	0.1 $\mu\text{F}$ X7R 10% 25V	MURATA	GRM21BR71E104KA01L
3	C <sub>IN</sub>	4.7 $\mu\text{F}$ X7R 10% 100V	TDK	C5750X7R2A475K
1	C <sub>O</sub>	6.8 $\mu\text{F}$ X7R 10% 50V	TDK	C4532X7R1H685K
1	C <sub>OV</sub>	47 pF COG/NPO 5% 50V	AVX	08055A470JAT2A
1	C <sub>T</sub>	1000 pF COG/NPO 5% 50V	MURATA	GRM2165C1H102JA01D
1	D1	Schottky 100V 12A	VISHAY	12CWQ10FNPF
1	L1	33 $\mu\text{H}$ 20% 6.3A	COILCRAFT	MSS1278-333MLB
1	Q1	NMOS 100V 32A	FAIRCHILD	FDD3682
1	Q2	PNP 150V 600 mA	FAIRCHILD	MMBT5401
1	R <sub>CSH</sub>	12.4 k $\Omega$ 1%	VISHAY	CRCW080512K4FKEA
1	R <sub>FS</sub>	10 $\Omega$ 1%	VISHAY	CRCW080510R0FKEA
2	R <sub>HSP</sub> , R <sub>HSN</sub>	1.0k $\Omega$ 1%	VISHAY	CRCW08051K00FKEA
1	R <sub>LIM</sub>	0.04 $\Omega$ 1% 1W	VISHAY	WSL2512R0400FEA
1	R <sub>OV1</sub>	15.8 k $\Omega$ 1%	VISHAY	CRCW080515K8FKEA
1	R <sub>OV2</sub>	499 k $\Omega$ 1%	VISHAY	CRCW0805499KFKEA
1	R <sub>SNS</sub>	0.1 $\Omega$ 1% 1W	VISHAY	WSL2512R1000FEA
1	R <sub>T</sub>	35.7 k $\Omega$ 1%	VISHAY	CRCW080535K7FKEA
1	R <sub>UV1</sub>	21 k $\Omega$ 1%	VISHAY	CRCW080521K0FKEA
1	R <sub>UV2</sub>	150 k $\Omega$ 1%	VISHAY	CRCW0805150KFKEA

## Applications Information

### DESIGN #2: BOOST PWM DIMMING APPLICATION - 9 LEDs at 1A

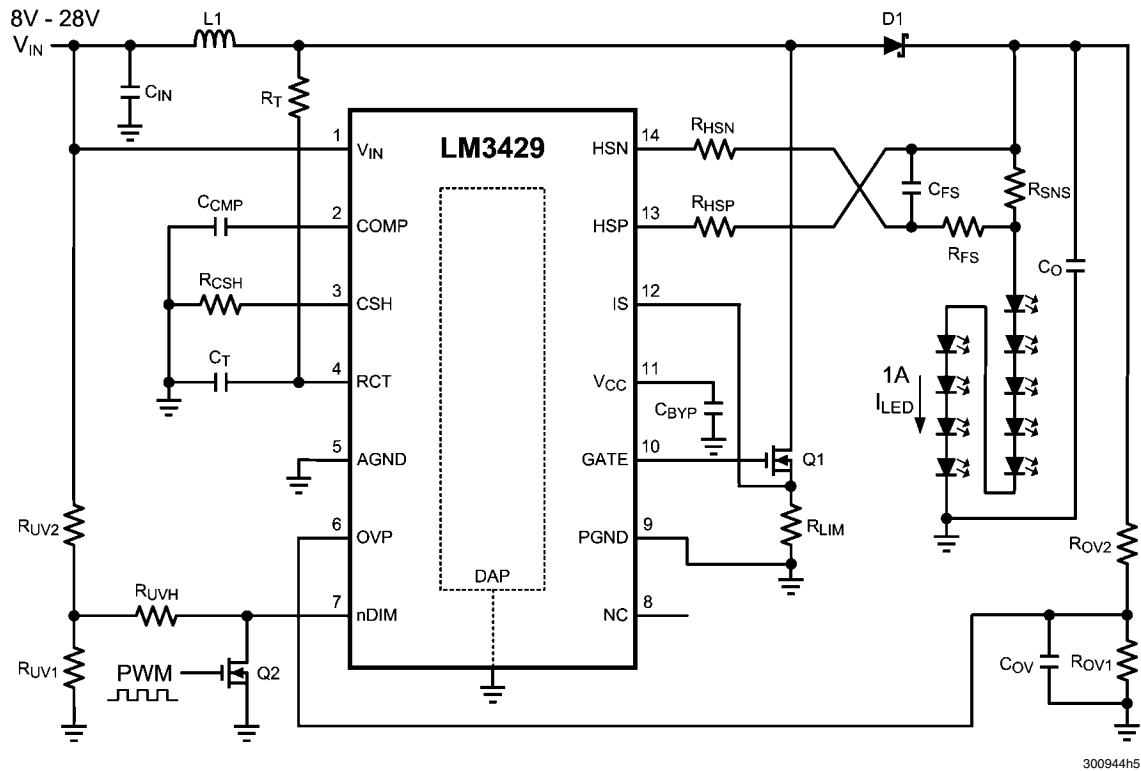

300944h5

### Design #2 Bill of Materials

Qty	Part ID	Part Value	Manufacturer	Part Number
1	LM3429	Boost controller	NSC	LM3429MH
2	$C_{COMP}, C_{FS}$	0.1 $\mu$ F X7R 10% 25V	MURATA	GRM21BR71E104KA01L
1	$C_F$	2.2 $\mu$ F X7R 10% 16V	MURATA	GRM21BR71C225KA12L
2, 1	$C_{IN}, C_O$	6.8 $\mu$ F X7R 10% 50V	TDK	C4532X7R1H685K
1	$C_{OV}$	47 pF COG/NPO 5% 50V	AVX	08055A470JAT2A
1	$C_T$	1000 pF COG/NPO 5% 50V	MURATA	GRM2165C1H102JA01D
1	D1	Schottky 60V 5A	COMCHIP	CDBC560-G
1	L1	33 $\mu$ H 20% 6.3A	COILCRAFT	MSS1278-333MLB
1	Q1	NMOS 60V 8A	VISHAY	SI4436DY
1	Q2	NMOS 60V 115 mA	ON SEMI	2N7002ET1G
2	$R_{CSH}, R_{OV1}$	12.4 k $\Omega$ 1%	VISHAY	CRCW080512K4FKEA
1	$R_{FS}$	10 $\Omega$ 1%	VISHAY	CRCW080510R0FKEA
2	$R_{HSP}, R_{HSN}$	1.0 k $\Omega$ 1%	VISHAY	CRCW08051K00FKEA
1	$R_{LIM}$	0.06 $\Omega$ 1% 1W	VISHAY	WSL2512R0600FEA
1	$R_{OV2}$	499 k $\Omega$ 1%	VISHAY	CRCW0805499KFKEA
1	$R_{SNS}$	0.1 $\Omega$ 1% 1W	VISHAY	WSL2512R1000FEA
1	$R_T$	35.7 k $\Omega$ 1%	VISHAY	CRCW080535K7FKEA
1	$R_{UV1}$	1.82 k $\Omega$ 1%	VISHAY	CRCW08051K82FKEA
1	$R_{UV2}$	10 k $\Omega$ 1%	VISHAY	CRCW080510KFKEA
1	$R_{UVH}$	17.8 k $\Omega$ 1%	VISHAY	CRCW080517K8FKEA

## DESIGN #3: BUCK-BOOST ANALOG DIMMING APPLICATION - 4 LEDs at 2A

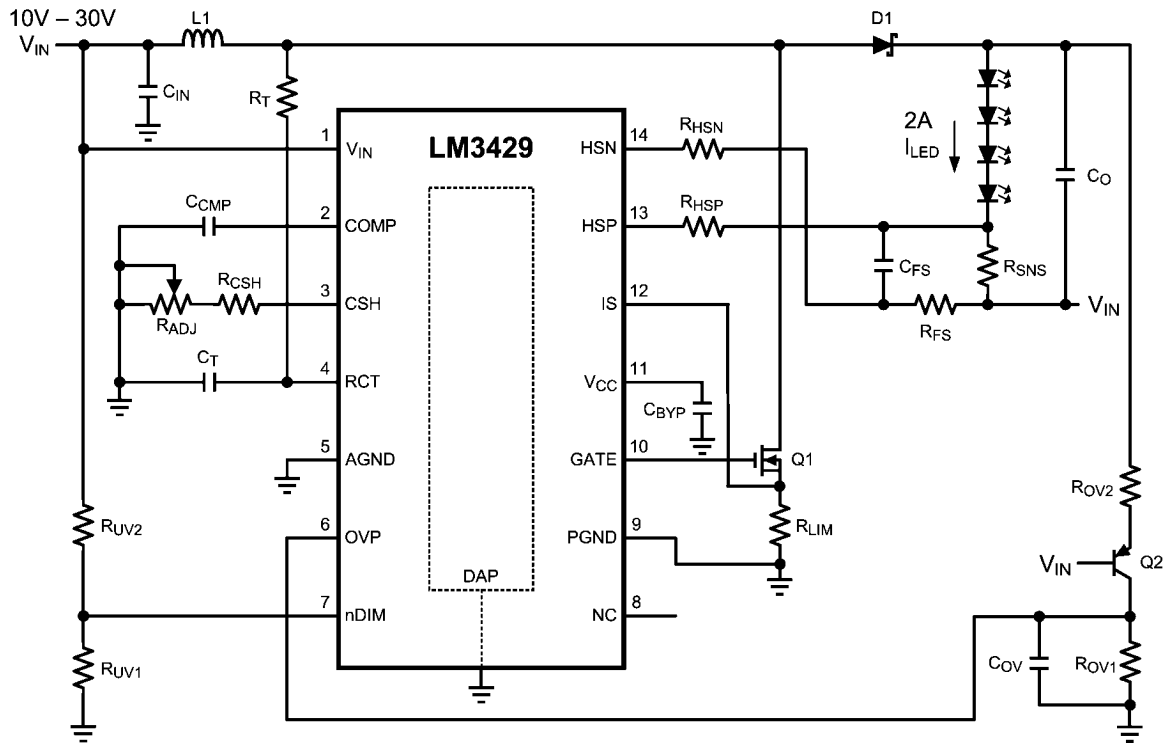

300944h6

## Design #3 Bill of Materials

Qty	Part ID	Part Value	Manufacturer	Part Number
1	LM3429	Boost controller	NSC	LM3429MH
1	C <sub>COMP</sub>	1.0 μF X7R 10% 10V	MURATA	GRM21BR71A105KA01L
1	C <sub>F</sub>	2.2 μF X7R 10% 16V	MURATA	GRM21BR71C225KA12L
1	C <sub>FS</sub>	0.1 μF X7R 10% 50V	MURATA	GRM21BR71E104KA01L
2, 1	C <sub>IN</sub> , C <sub>O</sub>	6.8 μF X7R 10% 50V	TDK	C4532X7R1H685K
1	C <sub>OV</sub>	47 pF COG/NPO 5% 50V	AVX	08055A470JAT2A
1	C <sub>T</sub>	1000 pF COG/NPO 5% 50V	MURATA	GRM2165C1H102JA01D
1	D1	Schottky 60V 5A	VISHAY	CDBC560-G
1	L1	22 μH 20% 7.2A	COILCRAFT	MSS1278-223MLB
1	Q1	NMOS 60V 8A	VISHAY	SI4436DY
1	Q2	PNP 150V 600 mA	FAIRCHILD	MMBT5401
1	R <sub>ADJ</sub>	1.0 MΩ potentiometer	BOURNS	3352P-1-105
1	R <sub>CSH</sub>	12.4 kΩ 1%	VISHAY	CRCW080512K4FKEA
1	R <sub>FS</sub>	10Ω 1%	VISHAY	CRCW080510R0FKEA
2	R <sub>HSP</sub> , R <sub>HSN</sub>	1.0 kΩ 1%	VISHAY	CRCW08051K00FKEA
1	R <sub>LIM</sub>	0.04Ω 1% 1W	VISHAY	WSL2512R0400FEA
1	R <sub>OV1</sub>	18.2 kΩ 1%	VISHAY	CRCW080518K2FKEA
1	R <sub>OV2</sub>	499 kΩ 1%	VISHAY	CRCW0805499KFKEA
1	R <sub>SNS</sub>	0.05Ω 1% 1W	VISHAY	WSL2512R0500FEA
1	R <sub>T</sub>	41.2 kΩ 1%	VISHAY	CRCW080541K2FKEA
1	R <sub>UV1</sub>	21 kΩ 1%	VISHAY	CRCW080521K0FKEA
1	R <sub>UV2</sub>	150 kΩ 1%	VISHAY	CRCW0805150KFKEA

## DESIGN #4: BOOST ANALOG DIMMING APPLICATION - 12 LEDs at 700mA

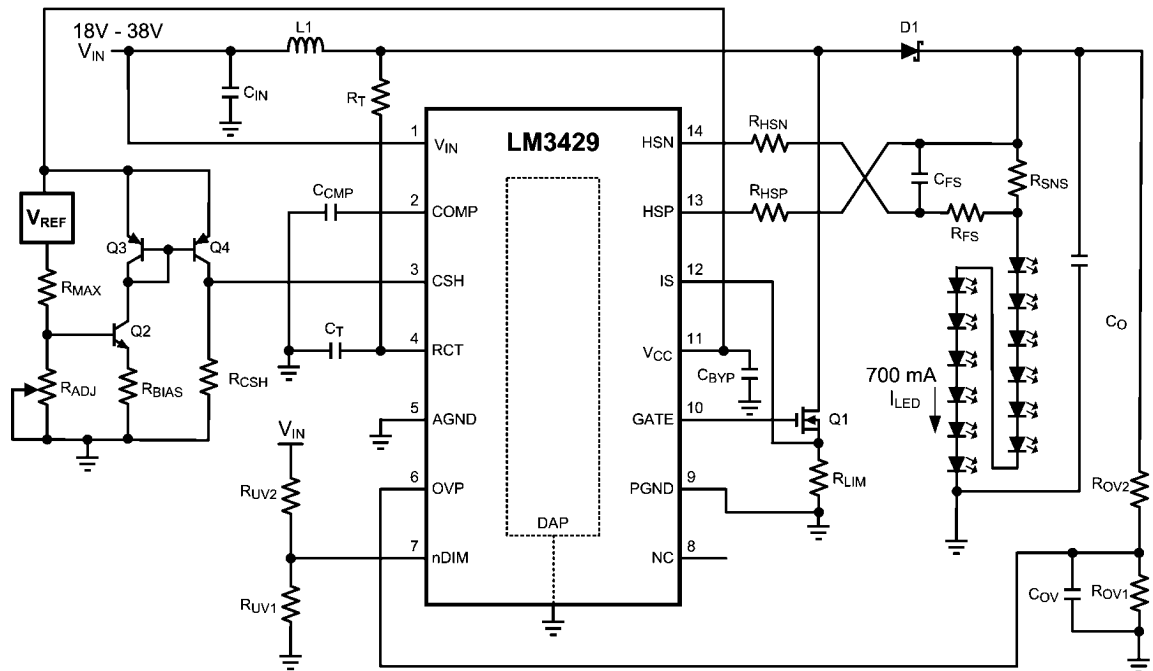

300944h7

## Design #4 Bill of Materials

Qty	Part ID	Part Value	Manufacturer	Part Number
1	LM3429	Boost controller	NSC	LM3429MH
1	C <sub>COMP</sub>	1.0 $\mu$ F X7R 10% 10V	MURATA	GRM21BR71A105KA01L
1	C <sub>F</sub>	2.2 $\mu$ F X7R 10% 16V	MURATA	GRM21BR71C225KA12L
1	C <sub>FS</sub>	0.1 $\mu$ F X7R 10% 50V	MURATA	GRM21BR71E104KA01L
2, 1	C <sub>IN</sub> , C <sub>O</sub>	6.8 $\mu$ F X7R 10% 50V	TDK	C4532X7R1H685K
1	C <sub>OV</sub>	47 pF COG/NPO 5% 50V	AVX	08055A470JAT2A
1	C <sub>T</sub>	1000 pF COG/NPO 5% 50V	MURATA	GRM2165C1H102JA01D
1	D1	Schottky 100V 12A	VISHAY	12CWQ10FNPF
1	L1	47 $\mu$ H 20% 5.3A	COILCRAFT	MSS1278-473MLB
1	Q1	NMOS 100V 32A	FAIRCHILD	FDD3682
1	Q2	NPN 40V 200 mA	FAIRCHILD	MMBT3904
1	Q3, Q4 (dual pack)	Dual PNP 40V 200 mA	FAIRCHILD	FFB3906
1	R <sub>ADJ</sub>	100 k $\Omega$ potentiometer	BOURNS	3352P-1-104
1	R <sub>BIAS</sub>	40.2 k $\Omega$ 1%	VISHAY	CRCW080540K2FKEA
1	R <sub>CSSH</sub> , R <sub>OV1</sub> , R <sub>UV1</sub>	12.4 k $\Omega$ 1%	VISHAY	CRCW080512K4FKEA
1	R <sub>FS</sub>	10 $\Omega$ 1%	VISHAY	CRCW080510R0FKEA
2	R <sub>HSP</sub> , R <sub>HSN</sub>	1.05 k $\Omega$ 1%	VISHAY	CRCW08051K05FKEA
1	R <sub>LIM</sub>	0.06 $\Omega$ 1% 1W	VISHAY	WSL2512R0600FEA
1	R <sub>MAX</sub>	4.99 k $\Omega$ 1%	VISHAY	CRCW08054K99FKEA
1	R <sub>OV2</sub>	499 k $\Omega$ 1%	VISHAY	CRCW0805499KFKEA
1	R <sub>SNS</sub>	0.15 $\Omega$ 1% 1W	VISHAY	WSL2512R1500FEA
1	R <sub>T</sub>	35.7 k $\Omega$ 1%	VISHAY	CRCW080535K7FKEA
1	R <sub>UV2</sub>	100 k $\Omega$ 1%	VISHAY	CRCW0805100KFKEA
1	V <sub>REF</sub>	5V precision reference	NSC	LM4040

## DESIGN #5: BUCK-BOOST PWM DIMMING APPLICATION - 6 LEDs at 500mA

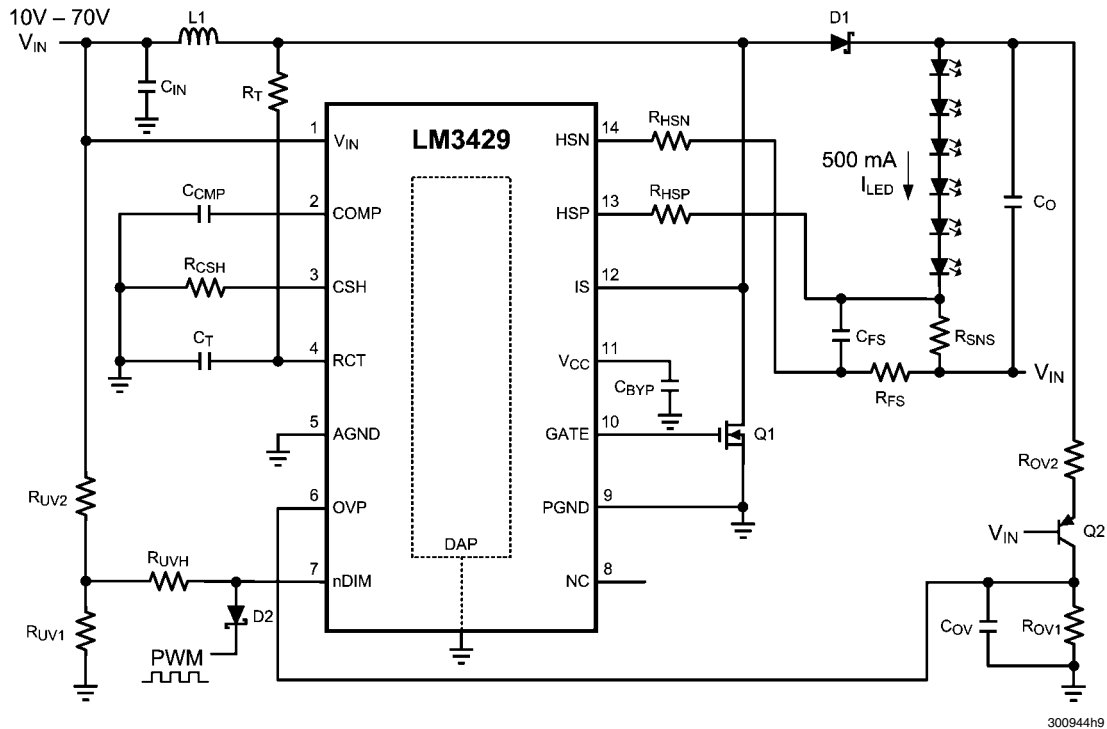

300944h9

## Design #5 Bill of Materials

Qty	Part ID	Part Value	Manufacturer	Part Number
1	LM3429	Boost controller	NSC	LM3429MH
1	C <sub>COMP</sub>	0.68 $\mu$ F X7R 10% 25V	MURATA	GRM21BR71E684KA88L
1	C <sub>F</sub>	2.2 $\mu$ F X7R 10% 16V	MURATA	GRM21BR71C225KA12L
1	C <sub>FS</sub>	0.1 $\mu$ F X7R 10% 25V	MURATA	GRM21BR71E104KA01L
3	C <sub>IN</sub>	4.7 $\mu$ F X7R 10% 100V	TDK	C5750X7R2A475K
1	C <sub>O</sub>	6.8 $\mu$ F X7R 10% 50V	TDK	C4532X7R1H685K
1	C <sub>OV</sub>	47 pF COG/NPO 5% 50V	AVX	08055A470JAT2A
1	C <sub>T</sub>	1000 pF COG/NPO 5% 50V	MURATA	GRM2165C1H102JA01D
1	D1	Schottky 100V 12A	VISHAY	12CWQ10FNPF
1	D2	Schottky 30V 500 mA	ON SEMI	BAT54T1G
1	L1	68 $\mu$ H 20% 4.3A	COILCRAFT	MSS1278-683MLB
1	Q1	NMOS 100V 32A	VISHAY	FDD3682
1	Q2	PNP 150V 600 mA	FAIRCHILD	MMBT5401
1	R <sub>CSH</sub>	12.4 k $\Omega$ 1%	VISHAY	CRCW080512K4FKEA
1	R <sub>FS</sub>	10 $\Omega$ 1%	VISHAY	CRCW080510R0FKEA
2	R <sub>HSP</sub> , R <sub>HSN</sub>	1.0 k $\Omega$ 1%	VISHAY	CRCW08051K00FKEA
1	R <sub>OV1</sub>	15.8 k $\Omega$ 1%	VISHAY	CRCW080515K8FKEA
1	R <sub>OV2</sub>	499 k $\Omega$ 1%	VISHAY	CRCW0805499KFKEA
1	R <sub>SNS</sub>	0.2 $\Omega$ 1% 1W	VISHAY	WSL2512R2000FEA
1	R <sub>T</sub>	35.7 k $\Omega$ 1%	VISHAY	CRCW080535K7FKEA
1	R <sub>UV1</sub>	1.43 k $\Omega$ 1%	VISHAY	CRCW08051K43FKEA
1	R <sub>UV2</sub>	10 k $\Omega$ 1%	VISHAY	CRCW080510K0FKEA
1	R <sub>UVH</sub>	17.4 k $\Omega$ 1%	VISHAY	CRCW080517K4FKEA

## DESIGN #6: BUCK APPLICATION - 3 LEDs AT 1.25A

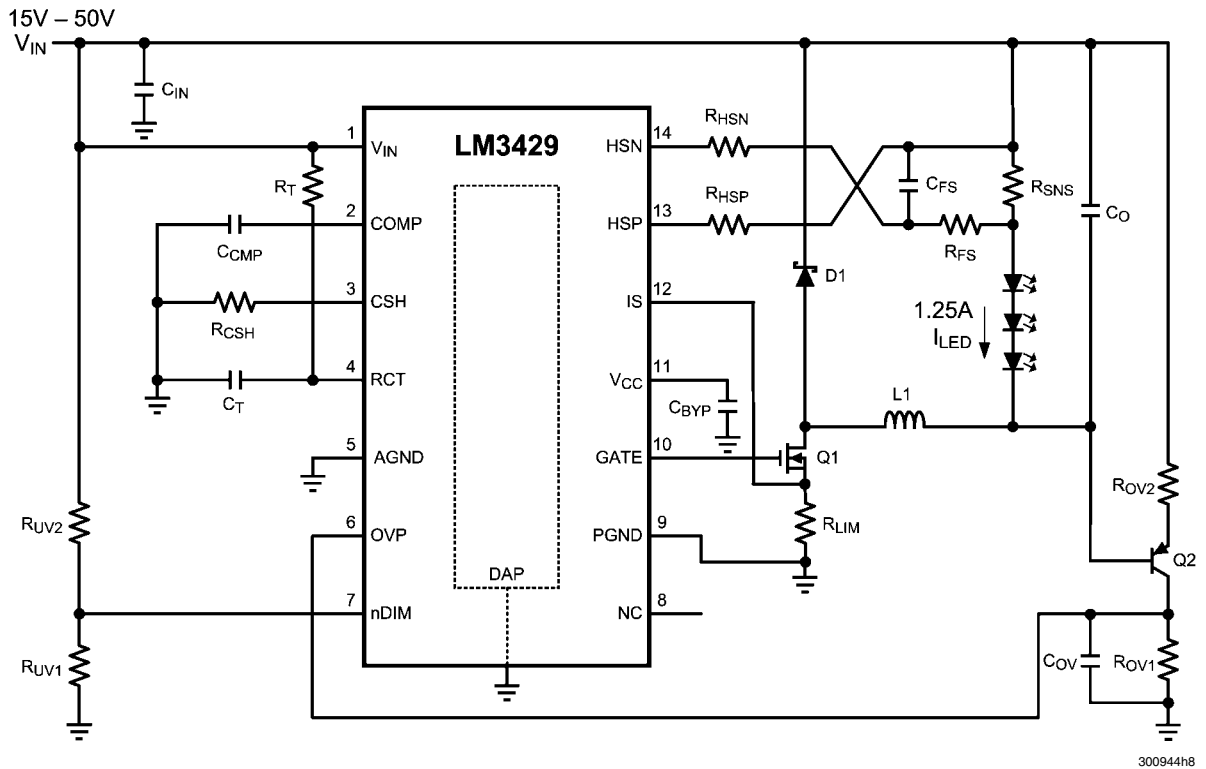

## Design #6 Bill of Materials

Qty	Part ID	Part Value	Manufacturer	Part Number
1	LM3429	Boost controller	NSC	LM3429MH
1	C <sub>COMP</sub>	0.015 $\mu$ F X7R 10% 50V	MURATA	GRM21BR71H153KA01L
1	C <sub>F</sub>	2.2 $\mu$ F X7R 10% 16V	MURATA	GRM21BR71C225KA12L
1	C <sub>FS</sub>	0.01 $\mu$ F X7R 10% 50V	MURATA	GRM21BR71H103KA01L
2	C <sub>IN</sub>	6.8 $\mu$ F X7R 10% 50V	TDK	C4532X7R1H685K
1	C <sub>O</sub>	1 $\mu$ F X7R 10% 50V	TDK	C4532X7R1H105K
1	C <sub>OV</sub>	47 pF COG/NPO 5% 50V	AVX	08055A470JAT2A
1	C <sub>T</sub>	1000 pF COG/NPO 5% 50V	MURATA	GRM2165C1H102JA01D
1	D1	Schottky 60V 5A	COMCHIP	CDBC560-G
1	L1	22 $\mu$ H 20% 7.3A	COILCRAFT	MSS1278-223MLB
1	Q1	NMOS 60V 8A	VISHAY	SI4436DY
1	Q2	PNP 150V 600 mA	FAIRCHILD	MMBT5401
1	R <sub>CSH</sub>	12.4 k $\Omega$ 1%	VISHAY	CRCW080512K4FKEA
1	R <sub>T</sub>	49.9 k $\Omega$ 1%	VISHAY	CRCW080549K9FKEA
1	R <sub>FS</sub>	10 $\Omega$ 1%	VISHAY	CRCW080510R0FKEA
2	R <sub>HSP</sub> , R <sub>HSN</sub>	1.0 k $\Omega$ 1%	VISHAY	CRCW08051K00FKEA
1	R <sub>LIM</sub>	0.04 $\Omega$ 1% 1W	VISHAY	WSL2512R0400FEA
1	R <sub>OV1</sub>	21.5 k $\Omega$ 1%	VISHAY	CRCW080521K5FKEA
1	R <sub>OV2</sub>	499 k $\Omega$ 1%	VISHAY	CRCW0805499KFKEA
1	R <sub>SNS</sub>	0.08 $\Omega$ 1% 1W	VISHAY	WSL2512R0800FEA
1	R <sub>UV1</sub>	11.5 k $\Omega$ 1%	VISHAY	CRCW080511K5FKEA
1	R <sub>UV2</sub>	100 k $\Omega$ 1%	VISHAY	CRCW0805100KFKEA

## DESIGN #7: BUCK-BOOST THERMAL FOLDBACK APPLICATION - 8 LEDs at 2.5A

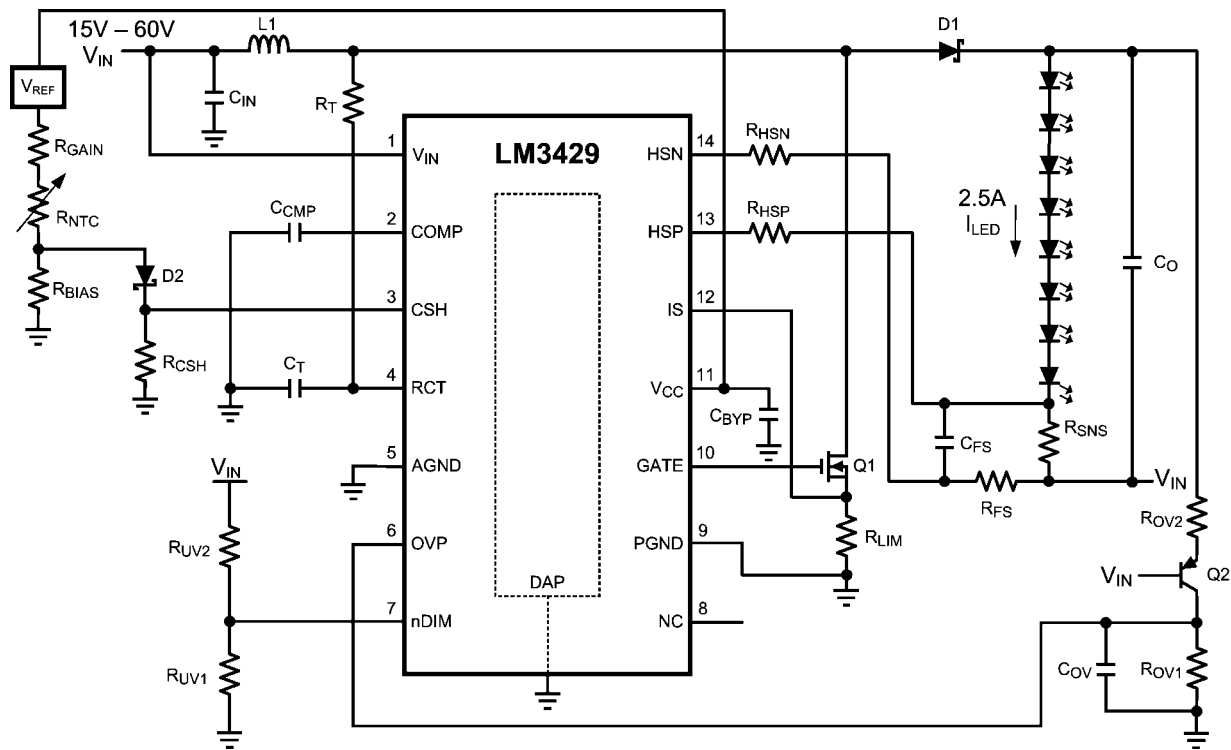

30094410

## Design #7 Bill of Materials

Qty	Part ID	Part Value	Manufacturer	Part Number
1	LM3429	Boost controller	NSC	LM3429MH
1	C <sub>COMP</sub>	0.1 $\mu$ F X7R 10% 25V	MURATA	GRM21BR71E104KA01L
1	C <sub>F</sub>	2.2 $\mu$ F X7R 10% 16V	MURATA	GRM21BR71C225KA12L
1	C <sub>F<sub>S</sub></sub>	0.1 $\mu$ F X7R 10% 25V	MURATA	GRM21BR71E104KA01L
3	C <sub>IN</sub>	4.7 $\mu$ F X7R 10% 100V	TDK	C5750X7R2A475K
1	C <sub>O</sub>	6.8 $\mu$ F X7R 10% 50V	TDK	C4532X7R1H685K
1	C <sub>OV</sub>	47 pF COG/NPO 5% 50V	AVX	08055A470JAT2A
1	C <sub>T</sub>	1000 pF COG/NPO 5% 50V	MURATA	GRM2165C1H102JA01D
1	D1	Schottky 100V 12A	VISHAY	12CWQ10FNPBF
1	L1	22 $\mu$ H 20% 7.2A	COILCRAFT	MSS1278-223MLB
1	Q1	NMOS 100V 32A	FAIRCHILD	FDD3682
1	Q2	PNP 150V 600 mA	FAIRCHILD	MMBT5401
2	R <sub>C<sub>SH</sub></sub> , R <sub>O<sub>V</sub>1</sub>	12.4 k $\Omega$ 1%	VISHAY	CRCW080512K4FKEA
1	R <sub>F<sub>S</sub></sub>	10 $\Omega$ 1%	VISHAY	CRCW080510R0FKEA
2	R <sub>H<sub>SP</sub></sub> , R <sub>H<sub>SN</sub></sub>	1.0 k $\Omega$ 1%	VISHAY	CRCW08051K00FKEA
2	R <sub>L<sub>IM</sub></sub> , R <sub>S<sub>NS</sub></sub>	0.04 $\Omega$ 1% 1W	VISHAY	WSL2512R0400FEA
1	R <sub>O<sub>V</sub>2</sub>	499 k $\Omega$ 1%	VISHAY	CRCW0805499KFKEA
1	R <sub>T</sub>	49.9 k $\Omega$ 1%	VISHAY	CRCW080549K9FKEA
1	R <sub>U<sub>V</sub>1</sub>	13.7 k $\Omega$ 1%	VISHAY	CRCW080513K7FKEA
1	R <sub>U<sub>V</sub>2</sub>	150 k $\Omega$ 1%	VISHAY	CRCW0805150KFKEA

## DESIGN #8: SEPIC APPLICATION - 5 LEDs at 750mA

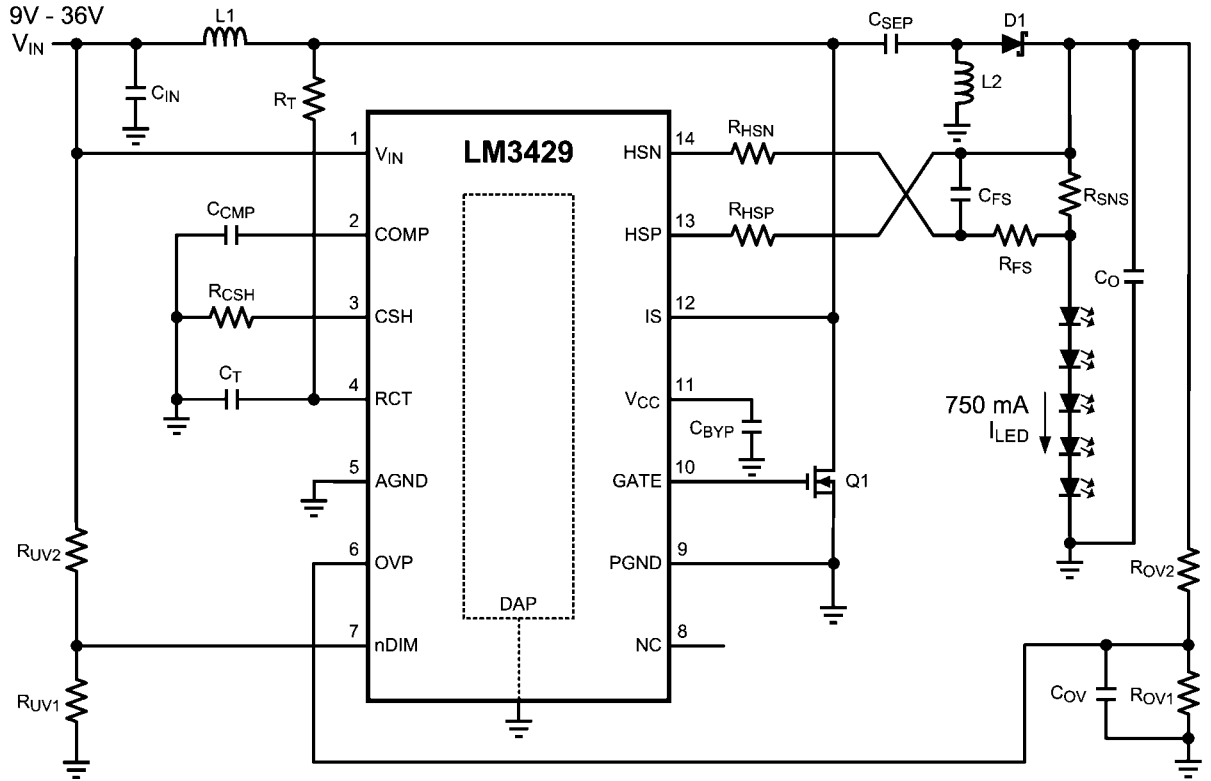

300944i8

## Design #8 Bill of Materials

Qty	Part ID	Part Value	Manufacturer	Part Number
1	LM3429	Boost controller	NSC	LM3429MH
1	C <sub>COMP</sub>	0.47 μF X7R 10% 25V	MURATA	GRM21BR71E474KA01L
1	C <sub>F</sub>	2.2 μF X7R 10% 16V	MURATA	GRM21BR71C225KA12L
1	C <sub>FS</sub>	0.1 μF X7R 10% 25V	MURATA	GRM21BR71E104KA01L
2, 1	C <sub>IN</sub> , C <sub>O</sub>	6.8 μF X7R 10% 50V	TDK	C4532X7R1H685K
1	C <sub>OV</sub>	47 pF COG/NPO 5% 50V	AVX	08055A470JAT2A
1	C <sub>T</sub>	1000 pF COG/NPO 5% 50V	MURATA	GRM2165C1H102JA01D
1	D1	Schottky 60V 5A	COMCHIP	CDBC560-G
1	L1, L2	68 μH 20% 4.3A	COILCRAFT	DO3340P-683
1	Q1	NMOS 60V 8A	VISHAY	SI4436DY
1	Q2	NMOS 60V 115 mA	ON SEMI	2N7002ET1G
1	R <sub>CSH</sub>	12.4 kΩ 1%	VISHAY	CRCW080512K4FKEA
1	R <sub>FS</sub>	10Ω 1%	VISHAY	CRCW080510R0FKEA
2	R <sub>HSP</sub> , R <sub>HSN</sub>	750Ω 1%	VISHAY	CRCW0805750RFKEA
1	R <sub>LIM</sub>	0.04Ω 1% 1W	VISHAY	WSL2512R0400FEA
2	R <sub>OV1</sub> , R <sub>UV1</sub>	15.8 kΩ 1%	VISHAY	CRCW080515K8FKEA
1	R <sub>OV2</sub>	499 kΩ 1%	VISHAY	CRCW0805499KFKEA
1	R <sub>SNS</sub>	0.1Ω 1% 1W	VISHAY	WSL2512R1000FEA
1	R <sub>T</sub>	49.9 kΩ 1%	VISHAY	CRCW080549K9FKEA
1	R <sub>UV2</sub>	100 kΩ 1%	VISHAY	CRCW0805100KFKEA



**Physical Dimensions** inches (millimeters) unless otherwise noted

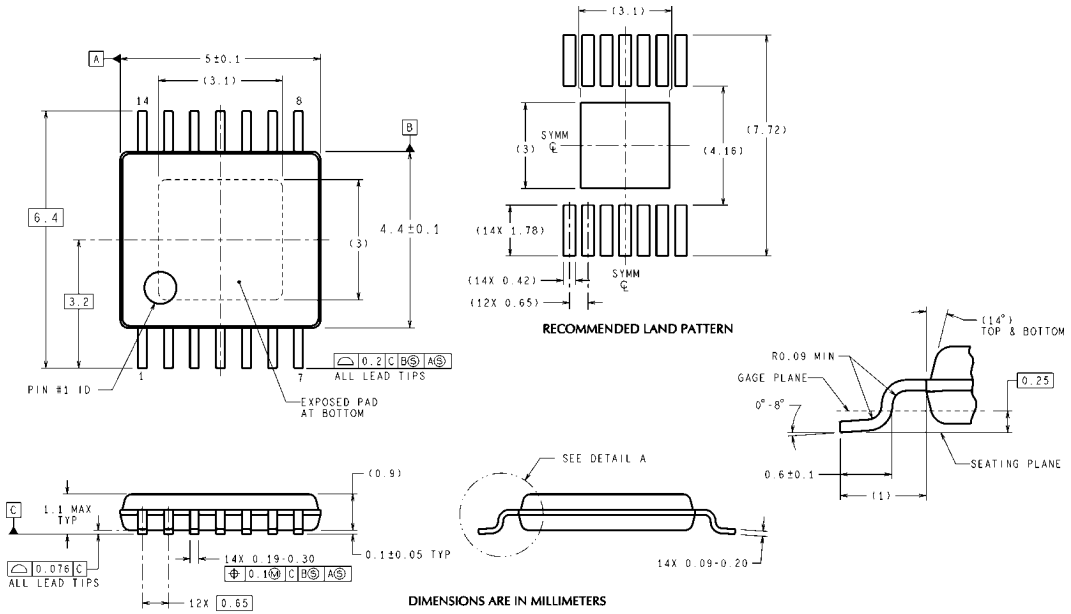

**TSSOP-14 Pin EP Package (MXA)**  
**For Ordering, Refer to Ordering Information Table**  
**NS Package Number MXA14A**

MXA14A (Rev A)

## Notes

For more National Semiconductor product information and proven design tools, visit the following Web sites at:

Products		Design Support	
Amplifiers	<a href="http://www.national.com/amplifiers">www.national.com/amplifiers</a>	WEBENCH® Tools	<a href="http://www.national.com/webench">www.national.com/webench</a>
Audio	<a href="http://www.national.com/audio">www.national.com/audio</a>	App Notes	<a href="http://www.national.com/appnotes">www.national.com/appnotes</a>
Clock and Timing	<a href="http://www.national.com/timing">www.national.com/timing</a>	Reference Designs	<a href="http://www.national.com/refdesigns">www.national.com/refdesigns</a>
Data Converters	<a href="http://www.national.com/adc">www.national.com/adc</a>	Samples	<a href="http://www.national.com/samples">www.national.com/samples</a>
Interface	<a href="http://www.national.com/interface">www.national.com/interface</a>	Eval Boards	<a href="http://www.national.com/evalboards">www.national.com/evalboards</a>
LVDS	<a href="http://www.national.com/lvds">www.national.com/lvds</a>	Packaging	<a href="http://www.national.com/packaging">www.national.com/packaging</a>
Power Management	<a href="http://www.national.com/power">www.national.com/power</a>	Green Compliance	<a href="http://www.national.com/quality/green">www.national.com/quality/green</a>
Switching Regulators	<a href="http://www.national.com/switchers">www.national.com/switchers</a>	Distributors	<a href="http://www.national.com/contacts">www.national.com/contacts</a>
LDOs	<a href="http://www.national.com/ldo">www.national.com/ldo</a>	Quality and Reliability	<a href="http://www.national.com/quality">www.national.com/quality</a>
LED Lighting	<a href="http://www.national.com/led">www.national.com/led</a>	Feedback/Support	<a href="http://www.national.com/feedback">www.national.com/feedback</a>
Voltage Reference	<a href="http://www.national.com/vref">www.national.com/vref</a>	Design Made Easy	<a href="http://www.national.com/easy">www.national.com/easy</a>
PowerWise® Solutions	<a href="http://www.national.com/powerwise">www.national.com/powerwise</a>	Solutions	<a href="http://www.national.com/solutions">www.national.com/solutions</a>
Serial Digital Interface (SDI)	<a href="http://www.national.com/sdi">www.national.com/sdi</a>	Mil/Aero	<a href="http://www.national.com/milaero">www.national.com/milaero</a>
Temperature Sensors	<a href="http://www.national.com/tempensors">www.national.com/tempensors</a>	SolarMagic™	<a href="http://www.national.com/solarmagic">www.national.com/solarmagic</a>
Wireless (PLL/VCO)	<a href="http://www.national.com/wireless">www.national.com/wireless</a>	PowerWise® Design University	<a href="http://www.national.com/training">www.national.com/training</a>

THE CONTENTS OF THIS DOCUMENT ARE PROVIDED IN CONNECTION WITH NATIONAL SEMICONDUCTOR CORPORATION ("NATIONAL") PRODUCTS. NATIONAL MAKES NO REPRESENTATIONS OR WARRANTIES WITH RESPECT TO THE ACCURACY OR COMPLETENESS OF THE CONTENTS OF THIS PUBLICATION AND RESERVES THE RIGHT TO MAKE CHANGES TO SPECIFICATIONS AND PRODUCT DESCRIPTIONS AT ANY TIME WITHOUT NOTICE. NO LICENSE, WHETHER EXPRESS, IMPLIED, ARISING BY ESTOPPEL OR OTHERWISE, TO ANY INTELLECTUAL PROPERTY RIGHTS IS GRANTED BY THIS DOCUMENT.

TESTING AND OTHER QUALITY CONTROLS ARE USED TO THE EXTENT NATIONAL DEEMS NECESSARY TO SUPPORT NATIONAL'S PRODUCT WARRANTY. EXCEPT WHERE MANDATED BY GOVERNMENT REQUIREMENTS, TESTING OF ALL PARAMETERS OF EACH PRODUCT IS NOT NECESSARILY PERFORMED. NATIONAL ASSUMES NO LIABILITY FOR APPLICATIONS ASSISTANCE OR BUYER PRODUCT DESIGN. BUYERS ARE RESPONSIBLE FOR THEIR PRODUCTS AND APPLICATIONS USING NATIONAL COMPONENTS. PRIOR TO USING OR DISTRIBUTING ANY PRODUCTS THAT INCLUDE NATIONAL COMPONENTS, BUYERS SHOULD PROVIDE ADEQUATE DESIGN, TESTING AND OPERATING SAFEGUARDS.

EXCEPT AS PROVIDED IN NATIONAL'S TERMS AND CONDITIONS OF SALE FOR SUCH PRODUCTS, NATIONAL ASSUMES NO LIABILITY WHATSOEVER, AND NATIONAL DISCLAIMS ANY EXPRESS OR IMPLIED WARRANTY RELATING TO THE SALE AND/OR USE OF NATIONAL PRODUCTS INCLUDING LIABILITY OR WARRANTIES RELATING TO FITNESS FOR A PARTICULAR PURPOSE, MERCHANTABILITY, OR INFRINGEMENT OF ANY PATENT, COPYRIGHT OR OTHER INTELLECTUAL PROPERTY RIGHT.

#### LIFE SUPPORT POLICY

**NATIONAL'S PRODUCTS ARE NOT AUTHORIZED FOR USE AS CRITICAL COMPONENTS IN LIFE SUPPORT DEVICES OR SYSTEMS WITHOUT THE EXPRESS PRIOR WRITTEN APPROVAL OF THE CHIEF EXECUTIVE OFFICER AND GENERAL COUNSEL OF NATIONAL SEMICONDUCTOR CORPORATION.** As used herein:

Life support devices or systems are devices which (a) are intended for surgical implant into the body, or (b) support or sustain life and whose failure to perform when properly used in accordance with instructions for use provided in the labeling can be reasonably expected to result in a significant injury to the user. A critical component is any component in a life support device or system whose failure to perform can be reasonably expected to cause the failure of the life support device or system or to affect its safety or effectiveness.

National Semiconductor and the National Semiconductor logo are registered trademarks of National Semiconductor Corporation. All other brand or product names may be trademarks or registered trademarks of their respective holders.

Copyright© 2009 National Semiconductor Corporation

For the most current product information visit us at [www.national.com](http://www.national.com)



**National Semiconductor  
Americas Technical  
Support Center**  
Email: [support@nsc.com](mailto:support@nsc.com)  
Tel: 1-800-272-9959

**National Semiconductor Europe  
Technical Support Center**  
Email: [europe.support@nsc.com](mailto:europe.support@nsc.com)

**National Semiconductor Asia  
Pacific Technical Support Center**  
Email: [ap.support@nsc.com](mailto:ap.support@nsc.com)

**National Semiconductor Japan  
Technical Support Center**  
Email: [jpn.feedback@nsc.com](mailto:jpn.feedback@nsc.com)