

LM3407

350 mA, Constant Current Output Floating Buck Switching Converter for High Power LEDs

General Description

The LM3407 is a constant current output floating buck switching converter designed to provide constant current to high power LEDs. The device is ideal for automotive, industrial and general lighting applications. The LM3407 has an integrated power N-MOSFET that makes the application solution compact and simple to implement. An external 1% thick-film resistor allows the converter output voltage to adjust as needed to deliver constant current within 10% accuracy to a serially connected LED string of varying number and type. Converter switching frequency is adjustable from 300 kHz to 1 MHz. The LM3407 features a dimming input to enable LED brightness control by Pulse Width Modulation (PWM). Additionally, a separate enable pin allows for low power shutdown. An exposed pad eMSOP-8 package provides excellent heat dissipation and thermal performance. Input UVLO and output open-circuit protection ensure a robust LED driver solution.

Features

- Input operating range 4.5V to 30V
- Output voltage range: $0.1V_{IN}$ to $0.9V_{IN}$
- Accurate constant current output
- Independent device enable (CMOS compatible) and PWM dimming control
- Converter switching frequency adjustable from 300 kHz to 1 MHz
- No external control loop compensation required
- Supports ceramic and low ESR output capacitors
- Input Under Voltage Lock Out (UVLO)
- Thermal shutdown protection
- eMSOP-8 Package

Applications

- LED Driver
- Constant Current Source
- Automotive Lighting
- General Illumination
- Industrial Lighting

Typical Application

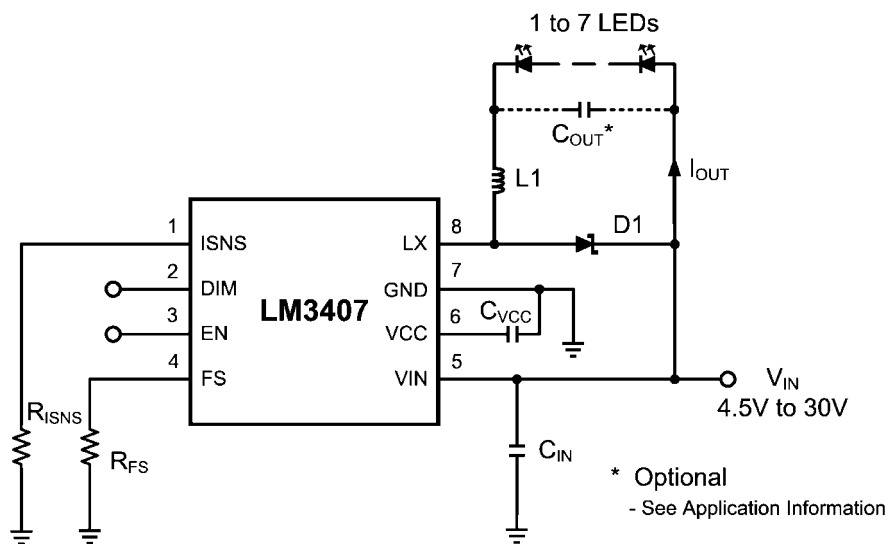

30046635

Connection Diagram

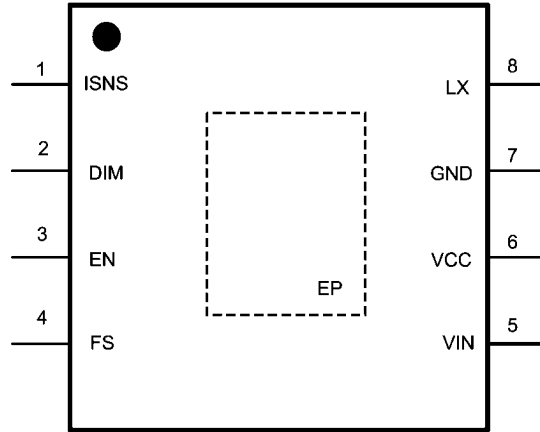

30046602

Top View
8-Lead Plastic eMSOP-8 Package
Mini SOIC Exp Pad (MUY08A)

Ordering Information

Order Number	Package Type	NSC Package Drawing	Supplied As
LM3407MY	eMSOP-8	MUY08A	1000 Units on Tape and Reel
LM3407MYX			3500 Units on Tape and Reel

Pin Descriptions

Pin(s)	Name	Description	Application Information
1	ISNS	LED Current Sense pin	Connect resistor R_{ISNS} from this pin to ground for LED current sensing. The current sensing resistor should be placed close to this pin.
2	DIM	PWM Dimming Input pin	Applying logic level PWM signal to this pin controls the average brightness of the LED string.
3	EN	Device Enable pin	Applying logic high to this pin or leaving this pin open enables the switcher. When this pin is pulled low, the switcher is disabled and will enter low power shutdown mode.
4	FS	Switching Frequency Setting pin	Connect resistor R_{FS} from this pin to ground to set the switching frequency.
5	VIN	Input Voltage pin	The input voltage should be in the range of 4.5V to 30V.
6	VCC	Internal Regulator Output pin	This output pin should be bypassed by a ceramic capacitor with a minimum value of 1 μ F. High quality X5R or X7R ceramic capacitor is recommended.
7	GND	Device Ground pin	This pin should be connected to the system ground.
8	LX	Drain of N-MOSFET Switch	Connect this pin to the output inductor and anode of the Schottky diode.
EP	GND	Thermal Pad	The bottom pad should be connected to ground. For good thermal performance, place 4 to 6 thermal vias from EP to bottom layer PCB ground plane.

Absolute Maximum Ratings (Note 1)

If Military/Aerospace specified devices are required, please contact the National Semiconductor Sales Office/Distributors for availability and specifications.

V _{IN} to GND	-0.3V to 36V
V _{IN} to GND (Transient)	42V (500 ms)
LX to GND	-0.3V to 36V
LX to GND (Transient)	-3V (2 ns), 42V (500 ms)
ISNS, FS, DIM, EN to GND	-0.3V to 7V
ESD Rating	
Human Body Model (Note 2)	2kV

Junction Temperature	150°C
Storage Temperature	-65°C to + 125°C
Soldering Information	
Lead Temperature (Soldering, 10sec)	260°C
Infrared or Convection (20sec)	235°C

Operating Ratings

V _{IN}	4.5V to 30V
Junction Temperature Range	-40°C to + 125°C
Thermal Resistance (θ _{JA}) (Note 3)	50°C/W

Electrical Characteristics V_{IN} = 12V unless otherwise indicated. Typical and limits appearing in plain type apply for T_A = T_J = 25°C (Note 4). Limits appearing in **boldface** type apply over full Operating Temperature Range. Datasheet min/max specification limits are guaranteed by design, test, or statistical analysis.

Symbol	Parameter	Conditions	Min	Typ	Max	Units
SYSTEM PARAMETERS						
I _{IN}	Operating Input Current	4.5V ≤ V _{IN} ≤ 30V	0.58	0.78	0.98	mA
		V _{EN} = 5V, V _{PWM} = 5V, LX = open				
I _Q	Quiescent Input current	4.5V ≤ V _{IN} ≤ 30V	0.20	0.27	0.39	mA
		V _{EN} = 5V, V _{PWM} = 0V				
I _{SHUT}	Shutdown Input Current	V _{EN} = 0V	36	48	60	μA
V _{UVLO}	Input Under Voltage Lock-out Threshold	V _{IN} Rising		3.6	4.5	V
V _{UVLO-HYS}	UVLO Hysteresis	V _{IN} Falling		200		mV
V _{EN_H}	EN pin HIGH Threshold	V _{EN} Rising		1.9	2.4	V
V _{EN_L}	EN pin LOW Threshold	V _{EN} Falling	1.3	1.75		V
V _{DIM_H}	DIM pin HIGH Threshold	V _{DIM} Rising		1.9	2.4	V
V _{DIM_L}	DIM pin LOW Threshold	V _{DIM} Falling	1.3	1.75		V
f _{SW}	Switching Frequency	R _T = 80 kΩ		500		kHz
		R _T = 40 kΩ		1000		
t _{ON-MIN}	Minimum On-time			200		ns
T _{SD}	Thermal Shutdown Threshold			165		°C
T _{SD-HYS}	Thermal Shutdown Hysteresis			25		°C
INTERNAL VOLTAGE REGULATOR						
V _{CC}	VCC Regulator Output Voltage (Note 5)	V _{IN} = 12V		4.5		V
N-MOSFET DRIVER						
R _{DS(ON)}	Main Switch ON Resistance	I _{sink} = 80mA		0.77	1.45	Ω
CONTROL LOOP						
A _{EA}	Error Amp Open Loop Gain			60		dB

Note 1: Absolute Maximum Ratings are limits beyond which damage to the device may occur. Operating Ratings are conditions under which operation of the device is intended to be functional. For guaranteed specifications and test conditions, see the Electrical Characteristics.

Note 2: The human body model is a 100pF capacitor discharged through a 1.5kΩ resistor into each pin.

Note 3: θ_{JA} of 50°C/W with thermal pad, EP soldered to a minimum of 2 square inches of 1 oz. Copper on the top or bottom PCB layer.

Note 4: Typical specification represent the most likely parametric norm at 25°C operation.

Note 5: V_{CC} provides self bias for the internal gate drive and control circuits. Device thermal limitations limit external loading to the pin.

Typical Performance Characteristics Unless otherwise specified, all curves shown are taken in typical application at $V_{IN} = 12V$, $T_A = 25^\circ C$, and $I_{LED} = 350\text{ mA}$ (driving two power LEDs).

Output Current vs Input Voltage
($T_A = -40^\circ C$)

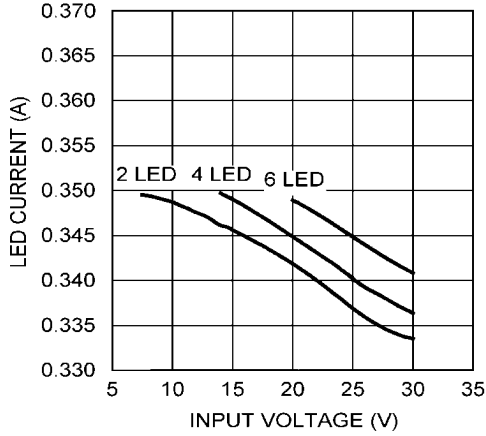

30046603

Output Current vs Input Voltage
($T_A = 25^\circ C$)

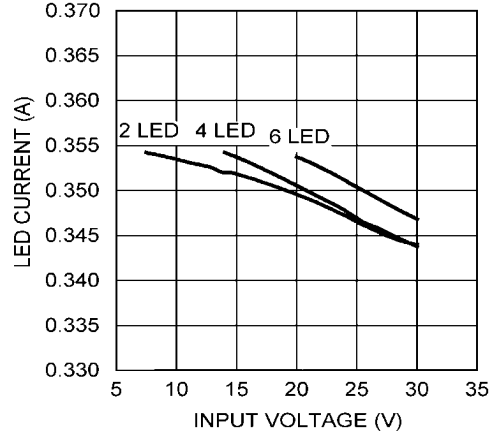

30046632

Output Current vs Input Voltage
($T_A = 125^\circ C$)

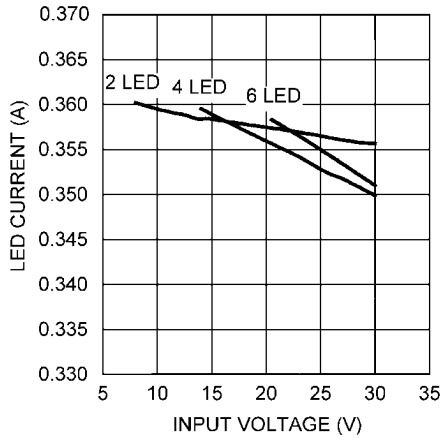

30046633

Efficiency vs Input Voltage
($T_A = -40^\circ C$)

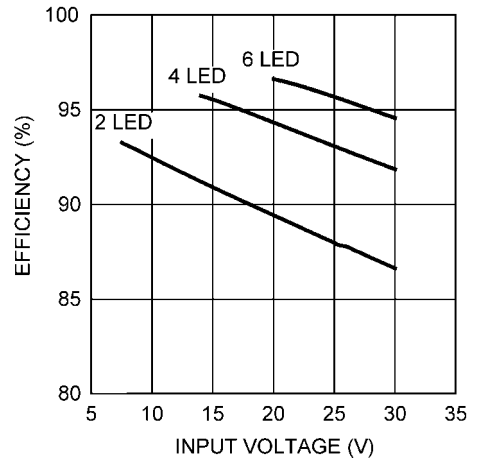

30046604

Efficiency vs Input Voltage
($T_A = 25^\circ C$)

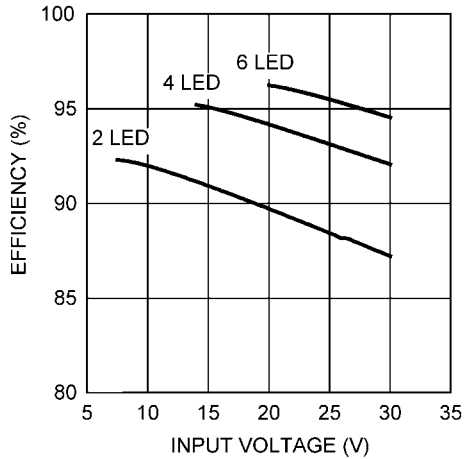

30046605

Efficiency vs Input Voltage
($T_A = 125^\circ C$)

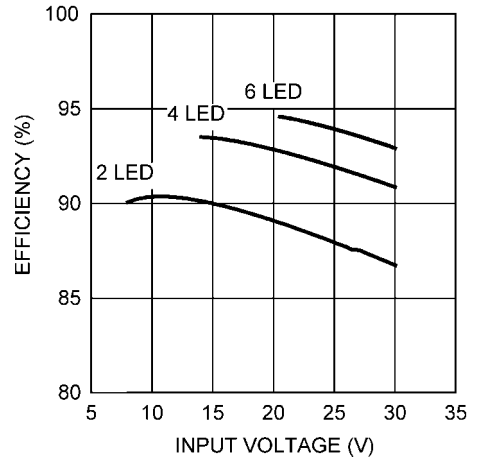

30046606

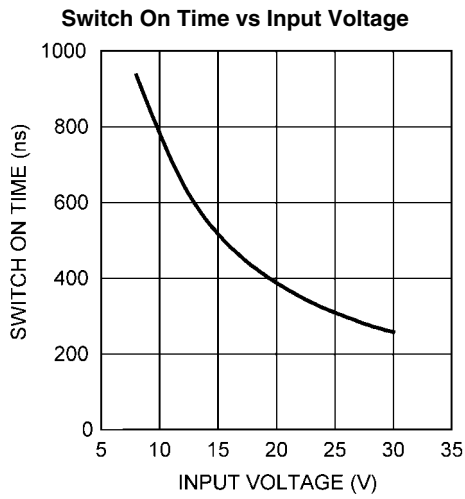

30046607

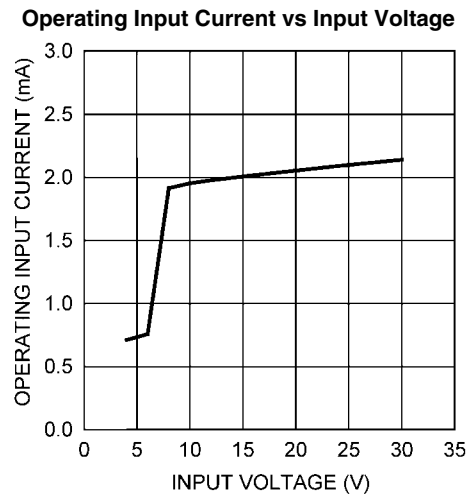

30046608

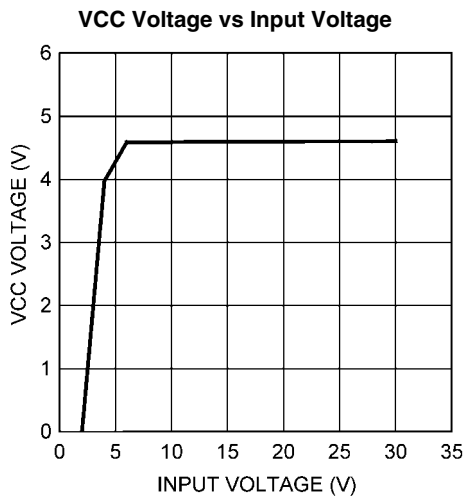

30046609

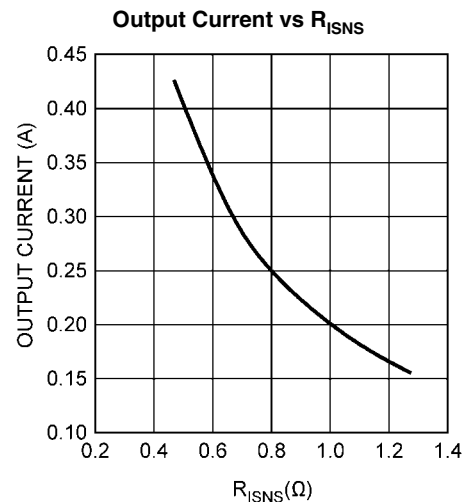

30046610

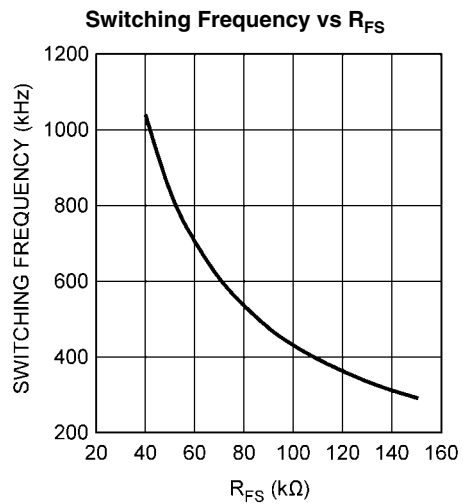

30046611

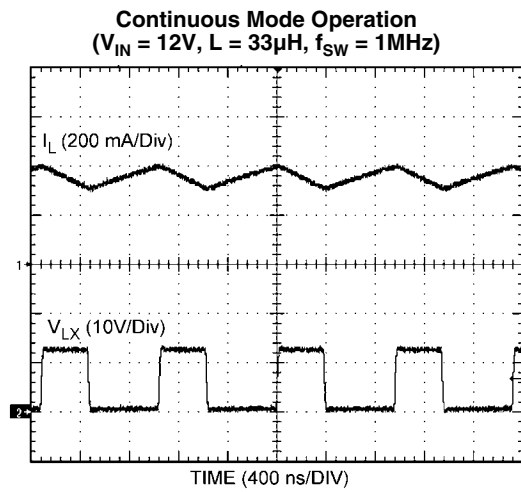

30046612

Continuous Mode Operation
 $(V_{IN} = 12V, L = 33\mu H, f_{SW} = 500kHz)$

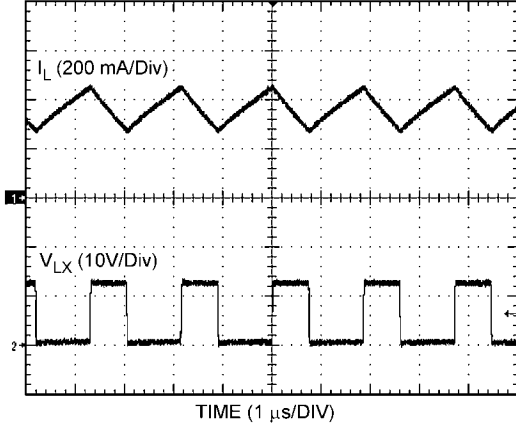

30046613

Continuous Mode Operation
 $(V_{IN} = 24V, L = 33\mu H, f_{SW} = 1MHz)$

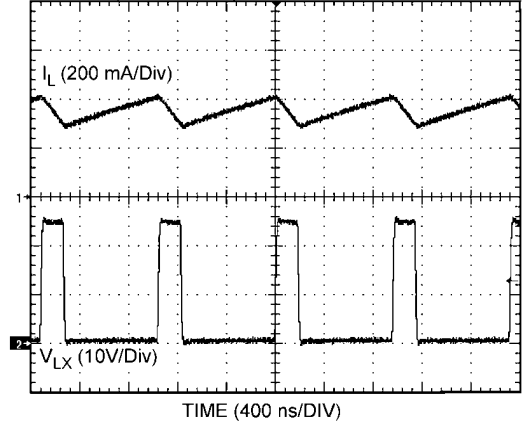

30046614

Continuous Mode Operation
 $(V_{IN} = 24V, L = 33\mu H, f_{SW} = 500kHz)$

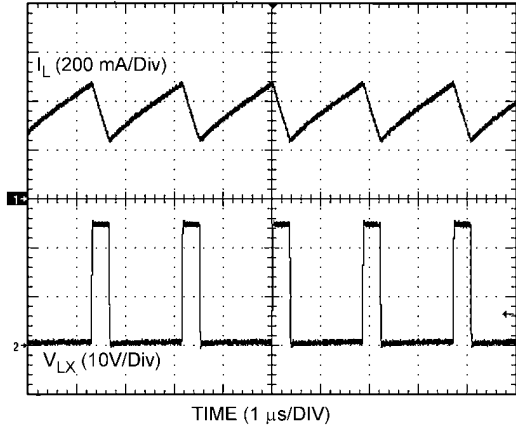

30046615

DIM Pin Enable Transient
 $(V_{IN} = 12V, L = 33\mu H, f_{SW} = 1MHz)$

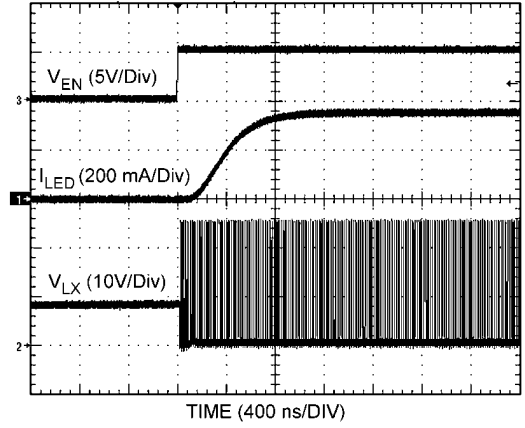

30046616

DIM Pin Disable Transient
 $(V_{IN} = 12V, L = 33\mu H, f_{SW} = 1MHz)$

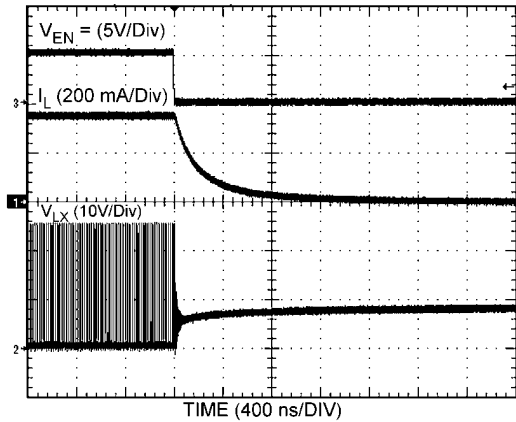

30046617

Simplified Functional Block Diagram

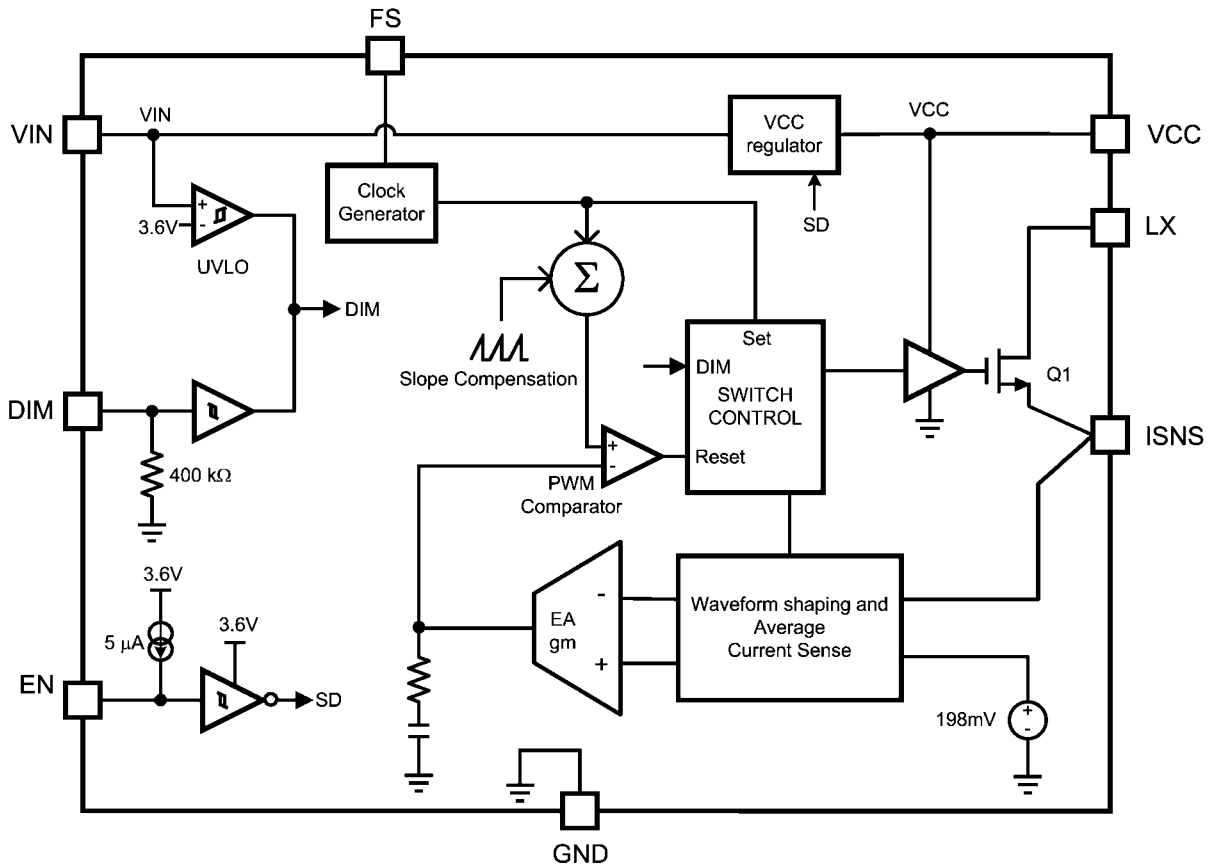

30046618

Functional Description

OVERVIEW

The LM3407 is a constant current output floating buck switching converter with wide input voltage range and low feedback current sense reference voltage. These characteristics make the LM3407 an efficient solution to provide constant current to high power LEDs. The device is ideal for automotive, industrial and general lighting applications where high power LEDs are used as the lighting source. The LM3407 has an integrated power N-MOSFET that makes the application solution compact and simple to implement. An external 1% thick-film resistor allows the converter output voltage to adjust as needed to deliver constant current within 10% accuracy to a serially connected LED string of varying number and type. Converter switching frequency is adjustable from 300 kHz to 1 MHz. The LM3407 features a dimming input to enable LED brightness control by Pulse Width Modulation (PWM). Additionally, a separate enable pin allows for low power shutdown. An exposed pad eMSP-8 package provides excellent heat dissipation and thermal performance. Input UVLO and output open-circuit protection ensure a robust LED driver solution.

FLOATING BUCK SWITCHING CONVERTER

The LM3407 is designed for floating buck configuration. Different from conventional buck converters, a low side power N-MOSFET is used. The floating buck configuration simplifies the driver stage design and reduces the die size of the power

MOSFET. Additionally, the connections of the power diode, inductor and output capacitor are switched to ground with a ground referenced power switch, Q1. The extraction of inductor current information can be easily realized by a simple current sensing resistor. These benefits combine to provide a high efficiency, low cost, and reliable solution for LED lighting applications.

The operation of the LM3407 constant current output floating buck converter is explained below. With the internal switch Q1 turned ON, current flows through the inductor L1 and the LED array. Energy is also stored in the magnetic field of the inductor during the ON cycle. The current flowing through R_{ISNS} during the ON cycle is monitored by the Average Current Sensing block. The switch will remain ON until the average inductor current equals $198\text{mV} / R_{ISNS}$. When the switch is turned OFF, the magnetic field starts to collapse and the polarity of the inductor voltage reverses. At the same time, the diode is forward biased and current flows through the LED, releasing the energy stored in the inductor to the output. True average output current is achieved as the switching cycle continuously repeats and the Average Current Sensing block controls the ON duty cycle. A constant current output floating buck converter only works in Continuous Conduction Mode (CCM); if the converter enters Discontinuous Conduction Mode (DCM) operation, the current regulation will deteriorate and the accuracy of LED current cannot be maintained. The operating waveforms for the typical application circuit are shown in *Figure 1*.

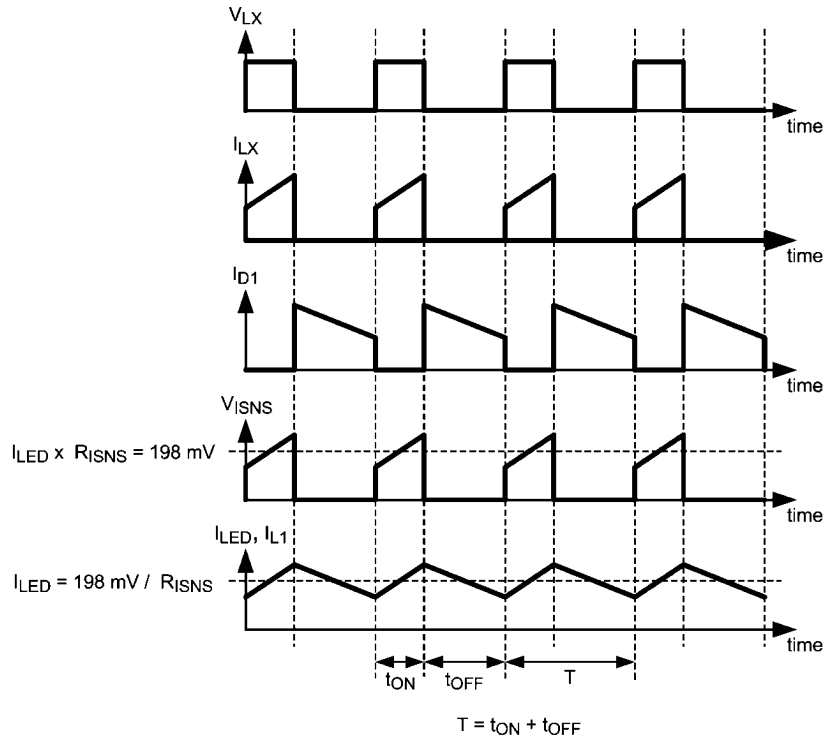

30046619

FIGURE 1. Operating Waveforms of a Floating Buck Converter

PULSE LEVEL MODULATION (PLM)

The LM3407 incorporates the innovative Pulse Level Modulation technique. With an external 1% thick film resistor connected to the ISNS pin, the converter output voltage can adjust automatically as needed to deliver constant current within 10% accuracy to a serially connected LED string of different number and type. Pulse Level Modulation is a novel method to provide precise constant current control with high efficiency. It allows the use of low side current sensing and facilitates true average output current regulation regardless

of the input voltage and inductor value. Pulse Level Modulation can be treated as a process that transforms a trapezoidal pulse chain into a square pulse chain with an amplitude equal to the center of inductor current ramp. *Figure 2* shows the waveform of the converter in steady state. In the figure, I_{L1} is the inductor current and I_{LX} is the switch current into the LX pin. V_{ISNS} is the voltage drop across the current sensing resistor R_{ISNS} . V_{MSL} is the center of the inductor current ramp and is a reference pulse that is synchronized and has an identical pulse width to V_{ISNS} .

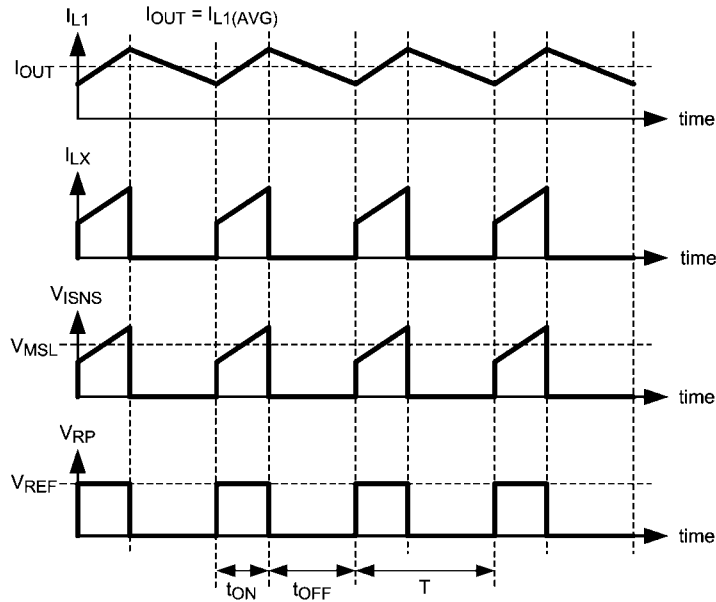

30046620

FIGURE 2. LM3407 Switching Waveforms

The switching frequency and duty ratio of the converter equal:

$$D = \frac{t_{ON}}{t_{ON} + t_{OFF}}$$

and

$$f_{SW} = \frac{1}{t_{ON} + t_{OFF}}$$

By comparing the area of V_{ISNS} and V_{RP} over the ON period, an error signal is generated. Such a comparison is functionally equivalent to comparing the middle level of I_{SNS} to V_{RP} during the ON-period of a switching cycle. The error signal is fed to a PWM comparator circuit to produce the PWM control pulse to drive the internal power N-MOSFET. *Figure 3* shows the implementation of the PWM switching signal. The error signal is fed to a PWM comparator circuit to produce the PWM control pulse to drive the internal power N-MOSFET. *Figure 3* shows the implementation of the PWM switching signal.

In closed loop operation, the difference between V_{MSL} and V_{RP} is reflected in the changes of the switching duty cycle of the power switch. This behavior is independent of the inductance of the inductor and input voltage because for the same set of $I_{OUT} * R_{ISNS}$, ON time, and switching period, there exists only one V_{MSL} . *Figure 4* shows two sets of current sense signals named V_{ISNS1} and V_{ISNS2} that have identical frequencies and duty cycles but different shapes of trapezoidal waveforms, each generating identical PWM signals.

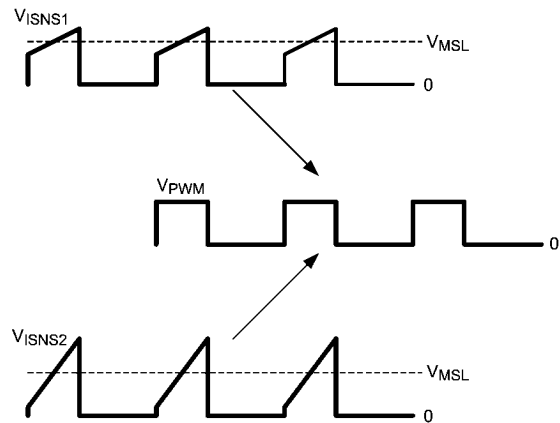

30046623

FIGURE 3. Pulse-Level Transformation

When V_{MSL} is higher than V_{REF} , the peak value of V_{RP} , the switching duty cycle of the power switch will be reduced to lower V_{MSL} . When V_{MSL} is lower than the peak value of V_{RP} , the switching duty cycle of the power switch will be increased to raise V_{MSL} . For example, when I_{OUT} is decreased, V_{MSL} will become lower than V_{REF} . In order to maintain output current regulation, the switching duty cycle of the power switch will be increased and eventually push up V_{MSL} until V_{MSL} equals V_{REF} . Since in typical floating buck regulators V_{MSL} is equal to $I_{OUT} * R_{ISNS}$, true average output current regulation can be achieved by regulating V_{MSL} . *Figure 5* shows the waveforms of V_{ISNS} and V_{RP} under closed loop operation.

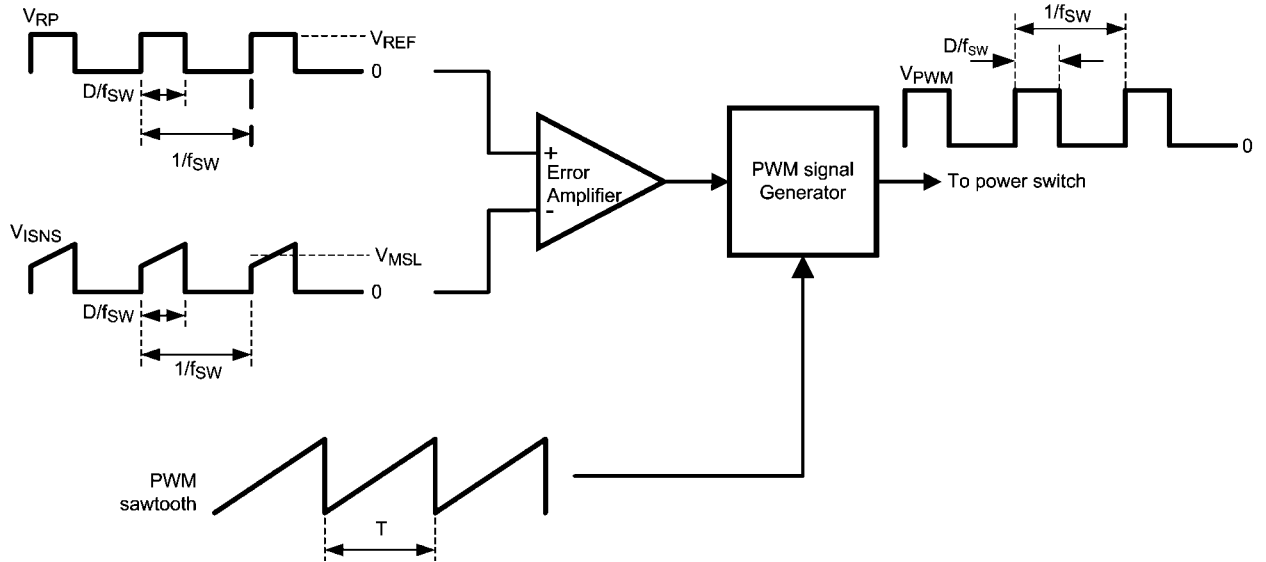

30046622

FIGURE 4. Implementation of the PWM Switching Signal

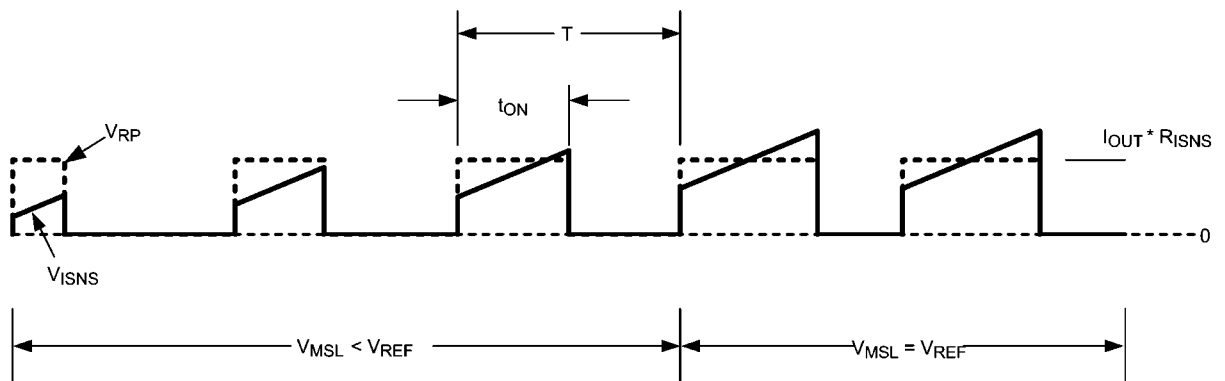

30046624

FIGURE 5. Waveforms of V_{ISNS} and V_{RP} Under Closed Loop Operation

INTERNAL VCC REGULATOR

The LM3407 has an internal 4.5V linear regulator. This regulated voltage is used for powering the internal circuitry only and any external loading at the VCC pin is not recommended. The supply input (V_{IN}) can be connected directly to an input voltage up to 30V. The VCC pin provides voltage regulated at 4.5V for $V_{IN} \leq 6V$. For $4.5V \leq V_{IN} \leq 6V$, VIN pin will be connected to VCC pin directly by an internal bypassing switch. For stability reason, an external capacitor C_{VCC} with at least 680 nF (1 μ F recommended) must be connected to the VCC pin.

CLOCK GENERATOR

The LM3407 features an integrated clock generator to control the switching frequency of the converter, f_{SW} . An external resistor R_{FS} , connected to the FS pin and ground, determines the switching frequency. The oscillator frequency can be set in the range of 300 kHz to 1 MHz. The relationship between the frequency setting resistance and the oscillator frequency is described in the Application Information Section.

PWM DIMMING OF LED STRING

Dimming of LED brightness is achieved by Pulse Width Modulation (PWM) control of the LED current. Pulse Width Modulation control allows LED brightness to be adjusted while still maintaining accurate LED color temperature. The LM3407 accepts an external PWM dimming signal at the DIM pin. The signal is buffered before being applied to the internal switch control block responsible for controlling the ON/OFF of the power switch, Q1. The DIM pin is internally pulled low by a resistor and no LED current will be available when the DIM pin is floating or shorted to ground. Functionally, the DIM pin can also be used as an external device disable control. Device switching will be disabled if the DIM pin is not connected or tied to ground.

LOW POWER SHUTDOWN MODE

The LM3407 comes with a dedicated device enable pin, EN, for low power shutdown of the device. By putting the device in shutdown mode, most of the internal circuits will be disabled and the input current will reduced to below typically 50 μ A. The

EN pin is internally pulled high by a 5µA current source. Connecting the EN pin to ground will force the device to enter low power shutdown mode. To resume normal operation, leave the EN pin open or drive with a logic high voltage.

INPUT UNDER-VOLTAGE LOCK-OUT (UVLO)

The LM3407 incorporates an input Under-Voltage Lock-Out (UVLO) circuit with hysteresis to keep the device disabled when the input voltage (V_{IN}) falls below the Lock-Out Low threshold, 3.4V typical. During the device power-up, internal circuits are held inactive and the UVLO comparator monitors the voltage level at the VIN pin continuously. When the VIN pin voltage exceeds the UVLO threshold, 3.6V typical, the internal circuits are then enabled and normal operation begins.

Application Information

SWITCHING FREQUENCY SELECTION

The selection of switching frequency is based on the consideration of the conversion efficiency, size of the passive components, and the total solution cost. In general, increasing the switching frequency will allow the use of smaller external components but will decrease the conversion efficiency. Thus, the selection of switching frequency is a compromise between the system requirements and may vary from design to design. The LM3407 switching frequency can be set in the range from 300 kHz to 1 MHz by adjusting the value of R_{FS} . The switching frequency is inversely proportional to the value of R_{FS} . In order to guarantee good operation stability, a resistor with 1% tolerance between 40 kΩ and 96 kΩ and with good thermal stability is suggested.

The switching frequency is estimated by the expression below:

$$f_{SW} = \frac{40 \text{ Meg}}{R_{FS}} + 40 \text{ in kHz}$$

In the equation, f_{SW} is the oscillator frequency and R_{FS} is the frequency setting resistance. The above equation is only valid for oscillator frequencies in the range of 300 kHz to 1 MHz, so the frequency setting resistance will be in the range of about 40 kΩ to 150 kΩ.

LED CURRENT SETTING

The LED current setting is important to the lifetime, reliability, and color temperature of the LED string. The LED current should be properly selected according to the characteristics of the LED used. Over-driving the LED array can cause the color temperature to shift and will shorten the lifetime of the LEDs. The output current of the LM3407 can be set by R_{ISNS} , which is calculated from the following equation:

$$R_{ISNS} = \frac{0.198V}{I_{OUT}}$$

To ensure the accuracy of the output current, a resistor with 1% tolerance should be used for R_{ISNS} . It is also important for the designer to ensure that the rated power of the resistor is not exceeded with reasonable margin. For example, when I_{OUT} is set to 350 mA, the total power dissipation on R_{ISNS} in steady state is $(0.35A)^2 \times 0.565\Omega$, which equals 69 mW, indicating a resistor of 1/8W power rating is appropriate.

INPUT AND OUTPUT CAPACITORS

The input capacitor supplies instantaneous current to the LM3407 converter when the internal power switch Q1 turns ON. The input capacitor filters the noise and transient voltage from the input power source. Using low ESR capacitors such as ceramic and tantalum capacitors is recommended. Similar to the selection criteria for the output capacitor, ceramic capacitors are the best choice for the input to the LM3407 due to their high ripple current rating, low ESR, and relatively small size compared to other types. A 4.7 µF X7R ceramic capacitor for the input capacitor is recommended.

The output capacitor C_{OUT} is used to reduce LED current ripple, filter noise, and smooth output voltage. This capacitor should have low ESR and adequate capacitance. Excessively large output capacitances create long enable and disable times, which is particularly significant when a high dimming frequency is used. Since the loading and input conditions differ from design to design, a 2.2 µF X7R ceramic capacitor is a good initial selection. A DC voltage rating equal to or higher than twice the forward voltage of the LED string is recommended.

C_{OUT} is optional and can be omitted for applications where small brightness variation is acceptable. Omitting C_{OUT} also helps reduce the cost and board size of the converter. With the absence of C_{OUT} , the LED forward current equals the inductor current. In order to ensure proper operation of the converter the peak inductor current must not exceed the rated forward current of the LEDs. Otherwise the LEDs may be damaged.

SELECTION OF INDUCTOR

In order to achieve accurate constant current output, the LM3407 is required to operate in Continuous Conduction Mode (CCM) under all operating conditions. In general, the magnitude of the inductor ripple current should be kept as small as possible. If the PCB size is not limited, higher inductance values result in better accuracy of the output current. However, in order to minimize the physical size of the circuit, an inductor with minimum physical outline should be selected such that the converter always operates in CCM and the peak inductor current does not exceed the saturation current limit of the inductor. The ripple and peak current of the inductor can be calculated as follows:

Inductor Peak to Peak Ripple Current:

$$I_{L(\text{ripple})} = \frac{\left[V_{IN} - (n \times V_F) - 0.198 \left(1 + \frac{1}{R_{ISNS}} \right) \right] \times (n \times V_F)}{L \times V_{IN} \times f_{SW}}$$

Peak Inductor Current:

$$I_{L(\text{peak})} = \frac{0.198}{R_{ISNS}} + \frac{I_{L(\text{ripple})}}{2}$$

where n is the number of LEDs in a string and V_F is the forward voltage of one LED.

The minimum inductance required for the specific application can be calculated by:

$$L_{\min} = \frac{\left[V_{\text{IN}} - (n \times V_{\text{F}}) - 0.198 \times \left(1 + \frac{1}{R_{\text{ISNS}}} \right) \right] \times (R_{\text{ISNS}} \times n \times V_{\text{F}})}{0.197 \times V_{\text{IN}} \times f_{\text{SW}}}$$

For applications with no output capacitor in place, the magnitude of the inductor ripple current should not be more than 20% of the average inductor current, which is equivalent to

the output current, I_{OUT} . However, in some situations the physical size of the required inductor may be too large and thus not allowed. The output capacitor can help absorb this current ripple to significantly reduce the ripple component along the LED string. With an output capacitor C_{OUT} in place, the magnitude of the inductor ripple current can be relaxed to 80% of the output current. *Figure 6* illustrates the relationship between I_{OUT} , $I_{\text{L(peak)}}$, and $I_{\text{L(ripple)}}$.

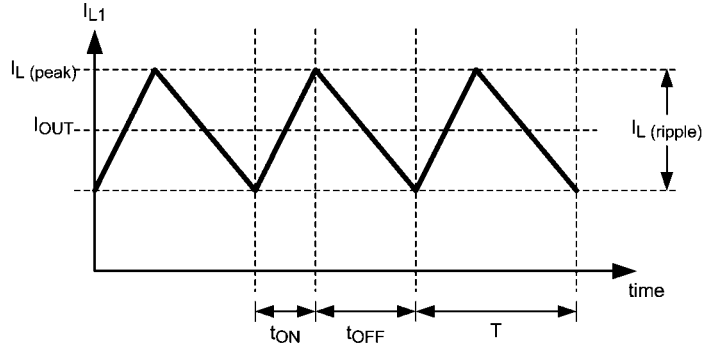

30046625

FIGURE 6. Relationship between I_{OUT} , $I_{\text{L(peak)}}$ and $I_{\text{L(ripple)}}$

Table 1 provides the suggested inductance of the inductor for 500 kHz and 1 MHz switching frequency operation with $C_{\text{OUT}} = 4.7\mu\text{F}$ and $I_{\text{L(ripple)}} = 0.8 \times I_{\text{OUT}}$

TABLE 1. Suggested Inductance Value of the Inductor

VIN / V	Number of LED						
	1	2	3	4	5	6	7
Inductor selection table for $F_{\text{SW}} = 500 \text{ kHz}$, $C_{\text{OUT}} = 4.7\mu\text{F}$ ($1\mu\text{F}$ for 1 LED)							
5	22 μH						
10	22 μH	22 μH					
15	22 μH	22 μH	22 μH				
20	22 μH	33 μH	22 μH	22 μH	22 μH		
25	22 μH	33 μH	33 μH	22 μH	22 μH	22 μH	
30	22 μH	47 μH	33 μH	33 μH	33 μH	22 μH	22 μH
Inductor selection table for $F_{\text{SW}} = 1 \text{ MHz}$, $C_{\text{OUT}} = 4.7\mu\text{F}$ ($1\mu\text{F}$ for 1 LED)							
5	22 μH						
10	22 μH	22 μH					
15	22 μH	22 μH	22 μH				
20	22 μH	22 μH	22 μH	22 μH	22 μH		
25	22 μH	33 μH	22 μH	22 μH	22 μH	22 μH	
30	22 μH	33 μH	33 μH	33 μH	22 μH	22 μH	22 μH

FREE-WHEELING DIODE

The LM3407 is a non-synchronous floating buck converter that requires an external free-wheeling diode to provide a path for recirculating current from the inductor to the LED array when the power switch is turned OFF. Selecting the free-wheeling diode depends on both the output voltage and cur-

rent. The diode must have a rated reverse voltage higher than the input voltage of the converter and a peak current rating higher than the expected maximum inductor current. Using a schottky diode with a low forward voltage drop can reduce power dissipation and enhance conversion efficiency.

PRINTED CIRCUIT BOARD DESIGN

Since the copper traces of PCBs carry resistance and parasitic inductance, the longer the copper trace, the higher the resistance and inductance. These factors introduce voltage and current spikes to the switching nodes and may impair circuit performance. To optimize the performance of the LM3407, the rule of thumb is to keep the connections between components as short and direct as possible. Since true average current regulation is achieved by detecting the average switch current, the current setting resistor R_{ISNS} must be located as close as possible to the LM3407 to reduce the parasitic inductance of the copper trace and avoid noise pick-up. The connections between the LX pin, rectifier D1, inductor

L1, and output capacitor C_{OUT} should be kept as short as possible to reduce the voltage spikes at the LX pin. It is recommended that C_{VCC} , the output filter capacitor for the internal linear regulator of the LM3407, be placed close to the VCC pin. The input filter capacitor C_{IN} should be located close to L1 and the cathode of D1. If C_{IN} is connected to the VIN pin by a long trace, a $0.1\mu\text{F}$ capacitor should be added close to VIN pin for noise filtering. In normal operation, heat will be generated inside the LM3407 and may damage the device if no thermal management is applied. For more details on switching power supply layout considerations see Application Note AN-1149: Layout Guidelines for Switching Power Supplies.

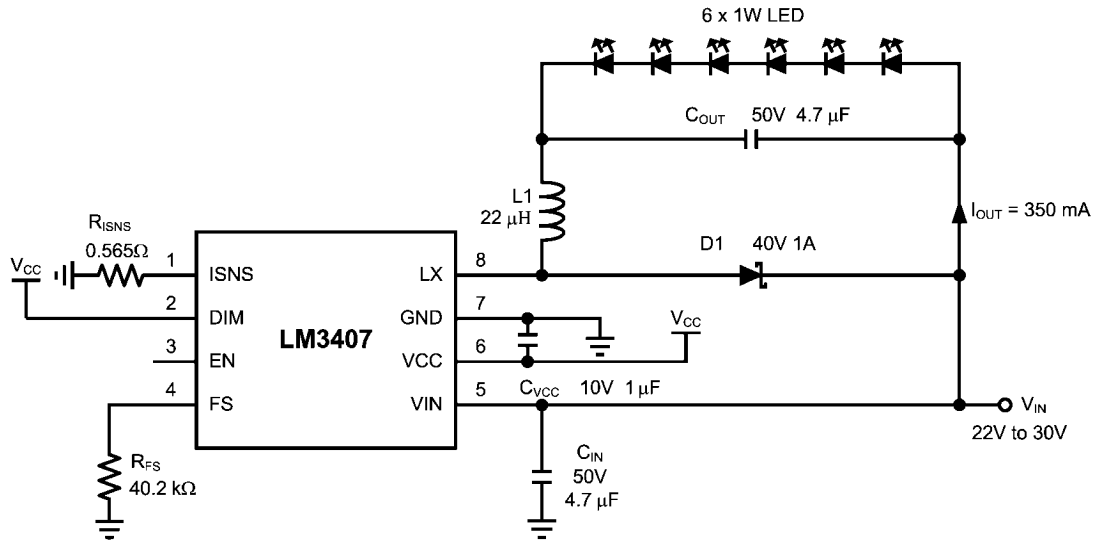

30046626

FIGURE 7. Typical Application Schematic for 6 LEDs

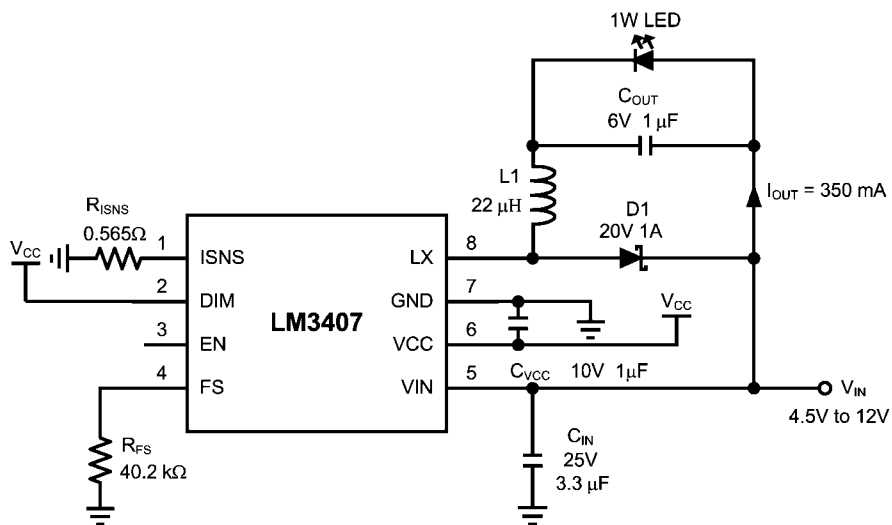

30046627

FIGURE 8. Typical Application Schematic for 1 LED

Physical Dimensions inches (millimeters) unless otherwise noted

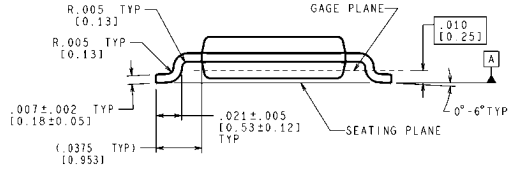
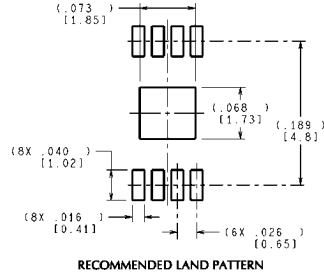
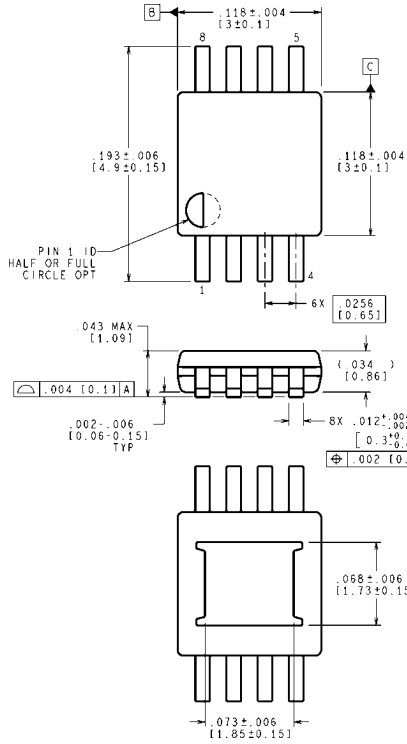

CONTROLLING DIMENSION IS INCH
VALUES IN [] ARE MILLIMETERS

8-Lead Plastic eMSOP Package
NS Package Number MUY08A

MUY08A (Rev A)

Notes

Notes

For more National Semiconductor product information and proven design tools, visit the following Web sites at:

Products		Design Support	
Amplifiers	www.national.com/amplifiers	WEBENCH® Tools	www.national.com/webench
Audio	www.national.com/audio	App Notes	www.national.com/appnotes
Clock and Timing	www.national.com/timing	Reference Designs	www.national.com/refdesigns
Data Converters	www.national.com/adc	Samples	www.national.com/samples
Interface	www.national.com/interface	Eval Boards	www.national.com/evalboards
LVDS	www.national.com/lvds	Packaging	www.national.com/packaging
Power Management	www.national.com/power	Green Compliance	www.national.com/quality/green
Switching Regulators	www.national.com/switchers	Distributors	www.national.com/contacts
LDOs	www.national.com/ldo	Quality and Reliability	www.national.com/quality
LED Lighting	www.national.com/led	Feedback/Support	www.national.com/feedback
Voltage Reference	www.national.com/vref	Design Made Easy	www.national.com/easy
PowerWise® Solutions	www.national.com/powerwise	Solutions	www.national.com/solutions
Serial Digital Interface (SDI)	www.national.com/sdi	Mil/Aero	www.national.com/milaero
Temperature Sensors	www.national.com/tempsensors	Solar Magic®	www.national.com/solarmagic
Wireless (PLL/VCO)	www.national.com/wireless	Analog University®	www.national.com/AU

THE CONTENTS OF THIS DOCUMENT ARE PROVIDED IN CONNECTION WITH NATIONAL SEMICONDUCTOR CORPORATION ("NATIONAL") PRODUCTS. NATIONAL MAKES NO REPRESENTATIONS OR WARRANTIES WITH RESPECT TO THE ACCURACY OR COMPLETENESS OF THE CONTENTS OF THIS PUBLICATION AND RESERVES THE RIGHT TO MAKE CHANGES TO SPECIFICATIONS AND PRODUCT DESCRIPTIONS AT ANY TIME WITHOUT NOTICE. NO LICENSE, WHETHER EXPRESS, IMPLIED, ARISING BY ESTOPPEL OR OTHERWISE, TO ANY INTELLECTUAL PROPERTY RIGHTS IS GRANTED BY THIS DOCUMENT.

TESTING AND OTHER QUALITY CONTROLS ARE USED TO THE EXTENT NATIONAL DEEMS NECESSARY TO SUPPORT NATIONAL'S PRODUCT WARRANTY. EXCEPT WHERE MANDATED BY GOVERNMENT REQUIREMENTS, TESTING OF ALL PARAMETERS OF EACH PRODUCT IS NOT NECESSARILY PERFORMED. NATIONAL ASSUMES NO LIABILITY FOR APPLICATIONS ASSISTANCE OR BUYER PRODUCT DESIGN. BUYERS ARE RESPONSIBLE FOR THEIR PRODUCTS AND APPLICATIONS USING NATIONAL COMPONENTS. PRIOR TO USING OR DISTRIBUTING ANY PRODUCTS THAT INCLUDE NATIONAL COMPONENTS, BUYERS SHOULD PROVIDE ADEQUATE DESIGN, TESTING AND OPERATING SAFEGUARDS.

EXCEPT AS PROVIDED IN NATIONAL'S TERMS AND CONDITIONS OF SALE FOR SUCH PRODUCTS, NATIONAL ASSUMES NO LIABILITY WHATSOEVER, AND NATIONAL DISCLAIMS ANY EXPRESS OR IMPLIED WARRANTY RELATING TO THE SALE AND/OR USE OF NATIONAL PRODUCTS INCLUDING LIABILITY OR WARRANTIES RELATING TO FITNESS FOR A PARTICULAR PURPOSE, MERCHANTABILITY, OR INFRINGEMENT OF ANY PATENT, COPYRIGHT OR OTHER INTELLECTUAL PROPERTY RIGHT.

LIFE SUPPORT POLICY

NATIONAL'S PRODUCTS ARE NOT AUTHORIZED FOR USE AS CRITICAL COMPONENTS IN LIFE SUPPORT DEVICES OR SYSTEMS WITHOUT THE EXPRESS PRIOR WRITTEN APPROVAL OF THE CHIEF EXECUTIVE OFFICER AND GENERAL COUNSEL OF NATIONAL SEMICONDUCTOR CORPORATION. As used herein:

Life support devices or systems are devices which (a) are intended for surgical implant into the body, or (b) support or sustain life and whose failure to perform when properly used in accordance with instructions for use provided in the labeling can be reasonably expected to result in a significant injury to the user. A critical component is any component in a life support device or system whose failure to perform can be reasonably expected to cause the failure of the life support device or system or to affect its safety or effectiveness.

National Semiconductor and the National Semiconductor logo are registered trademarks of National Semiconductor Corporation. All other brand or product names may be trademarks or registered trademarks of their respective holders.

Copyright© 2009 National Semiconductor Corporation

For the most current product information visit us at www.national.com



National Semiconductor Americas Technical Support Center
 Email: support@nsc.com
 Tel: 1-800-272-9959

National Semiconductor Europe Technical Support Center
 Email: europe.support@nsc.com
 German Tel: +49 (0) 180 5010 771
 English Tel: +44 (0) 870 850 4288

National Semiconductor Asia Pacific Technical Support Center
 Email: ap.support@nsc.com

National Semiconductor Japan Technical Support Center
 Email: jpn.feedback@nsc.com