

LM3405

1.6MHz, 1A Constant Current Buck Regulator for Powering LEDs

General Description

Integrated with a 1A power switch, the LM3405 is a current-mode control switching buck regulator designed to provide a simple, high efficiency solution for driving high power LEDs. With a 0.205V reference voltage feedback control to minimize power dissipation, an external resistor sets the current as needed for driving various types of LEDs. Switching frequency is internally set to 1.6MHz, allowing small surface mount inductors and capacitors to be used. The LM3405 utilizes current-mode control and internal compensation offering ease of use and predictable, high performance regulation over a wide range of operating conditions. Additional features include user accessible EN/DIM pin for enabling and PWM dimming of LEDs, thermal shutdown, cycle-by-cycle current limit and over-current protection.

Features

- V_{IN} operating range of 3V to 15V
- Thin SOT23-6 package
- 1.6MHz switching frequency
- 300m Ω NMOS switch
- 40nA shutdown current at $V_{IN} = 5V$
- EN/DIM input for enabling and PWM dimming of LEDs
- Internally compensated current-mode control
- Cycle-by-cycle current limit
- Input voltage UVLO
- Over-current protection
- Thermal shutdown

Applications

- LED Driver
- Constant Current Source
- Industrial Lighting
- LED Flashlights

Typical Application Circuit

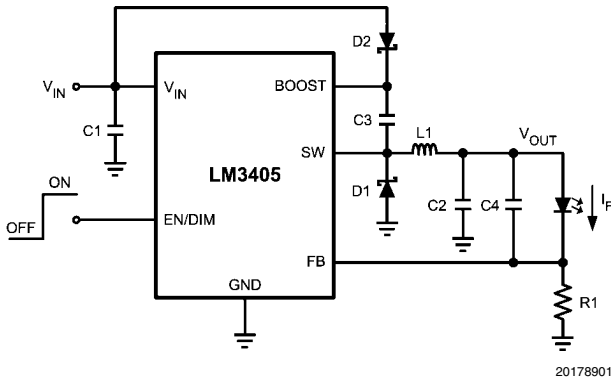

Efficiency vs LED Current ($V_{IN} = 5V$)

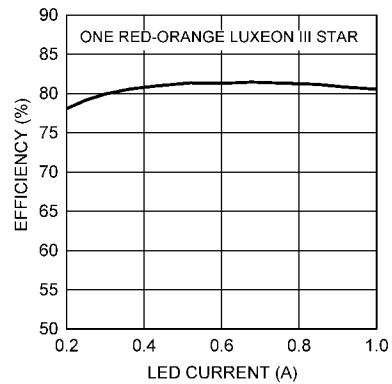

20178971

Connection Diagrams

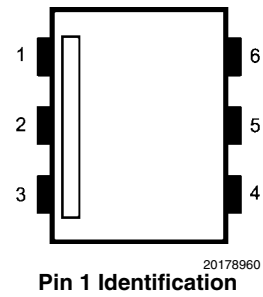
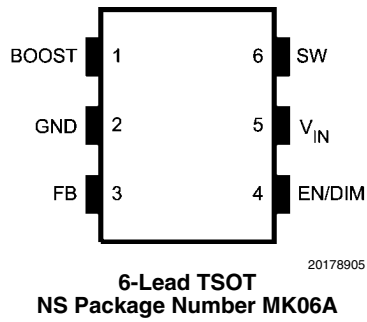

Ordering Information

Part Number	Package Type	NS Package Drawing	Package Marking	Supplied As
LM3405XMK	TSOT-6	MK06A	SPNB	1000 Units on Tape and Reel
LM3405XMKX			SPNB	3000 Units on Tape and Reel

*NOPB versions are available

Pin Descriptions

Pin(s)	Name	Application Information
1	BOOST	Voltage at this pin drives the internal NMOS power switch. A bootstrap capacitor is connected between the BOOST and SW pins.
2	GND	Signal and Power ground pin. Place the LED current-setting resistor as close as possible to this pin for accurate current regulation.
3	FB	Feedback pin. Connect an external resistor from FB to GND to set the LED Current.
4	EN/DIM	Enable control input. Logic high enables operation. Toggling this pin with a periodic logic square wave of varying duty cycle at different frequencies controls the brightness of LEDs. Do not allow this pin to float or be greater than $V_{IN} + 0.3V$.
5	V_{IN}	Input supply voltage. Connect a bypass capacitor locally from this pin to GND.
6	SW	Switch pin. Connect this pin to the inductor, catch diode, and bootstrap capacitor.

Absolute Maximum Ratings (Note 1)

If Military/Aerospace specified devices are required, please contact the National Semiconductor Sales Office/Distributors for availability and specifications.

V_{IN}	-0.5V to 20V
SW Voltage	-0.5V to 20V
Boost Voltage	-0.5V to 26V
Boost to SW Voltage	-0.5V to 6.0V
FB Voltage	-0.5V to 3.0V
EN/DIM Voltage	-0.5V to ($V_{IN} + 0.3V$)
Junction Temperature	150°C

ESD Susceptibility (Note 2)

2kV

Storage Temperature

-65°C to +150°C

Soldering Information

Infrared/Convection Reflow (15sec)

220°C

Operating Ratings (Note 1)

V_{IN}	3V to 15V
EN/DIM voltage	-0.5V to ($V_{IN} + 0.3V$)
Boost to SW Voltage	2.5V to 5.5V
Junction Temperature Range	-40°C to +125°C
Thermal Resistance θ_{JA} (Note 3)	118°C/W

Electrical Characteristics

Unless otherwise specified, $V_{IN} = 12V$. Limits in standard type are for $T_J = 25^\circ C$ only; limits in **boldface type** apply over the junction temperature (T_J) range of -40°C to +125°C. Minimum and Maximum limits are guaranteed through test, design, or statistical correlation. Typical values represent the most likely parametric norm, and are provided for reference purposes only.

Symbol	Parameter	Conditions	Min	Typ	Max	Units
V_{FB}	Feedback Voltage		0.188	0.205	0.220	V
$\Delta V_{FB}/(\Delta V_{IN} \times V_{FB})$	Feedback Voltage Line Regulation	$V_{IN} = 3V$ to 15V		0.01		%/V
I_{FB}	Feedback Input Bias Current	Sink/Source		10	250	nA
UVLO	Under-voltage Lockout	V_{IN} Rising		2.74	2.95	V
	Under-voltage Lockout	V_{IN} Falling	1.9	2.3		V
	UVLO Hysteresis			0.44		V
f_{SW}	Switching Frequency		1.2	1.6	1.9	MHz
D_{MAX}	Maximum Duty Cycle	$V_{FB} = 0V$	85	94		%
$R_{DS(ON)}$	Switch ON Resistance	$V_{BOOST} - V_{SW} = 3V$		300	600	m Ω
I_{CL}	Switch Current Limit	$V_{BOOST} - V_{SW} = 3V$, $V_{IN} = 3V$	1.2	2.0	2.8	A
I_Q	Quiescent Current	Switching, $V_{FB} = 0.195V$		1.8	2.8	mA
	Quiescent Current (Shutdown)	$V_{EN/DIM} = 0V$		0.3		μA
V_{EN/DIM_TH}	Enable Threshold Voltage	$V_{EN/DIM}$ Rising	1.8			V
	Shutdown Threshold Voltage	$V_{EN/DIM}$ Falling			0.4	V
$I_{EN/DIM}$	EN/DIM Pin Current	Sink/Source		0.01		μA
I_{SW}	Switch Leakage	$V_{IN} = 15V$		0.1		μA

Note 1: Absolute Maximum Ratings are limits beyond which damage to the device may occur. Operating Ratings define the conditions under which the device is intended to be functional. For guaranteed specifications and test conditions, see the Electrical Characteristics.

Note 2: Human body model, 1.5k Ω in series with 100pF.

Note 3: Thermal shutdown will occur if the junction temperature (T_J) exceeds 165°C. The maximum allowable power dissipation (P_D) at any ambient temperature (T_A) is $P_D = (T_{J(MAX)} - T_A)/\theta_{JA}$. This number applies to packages soldered directly onto a 3" x 3" PC board with 2oz. copper on 4 layers in still air. For a 2 layer board using 1 oz. copper in still air, $\theta_{JA} = 204^\circ C/W$.

Typical Performance Characteristics

Unless otherwise specified, $V_{IN} = 12V$, $V_{BOOST} - V_{SW} = 5V$ and

$T_A = 25^\circ C$.

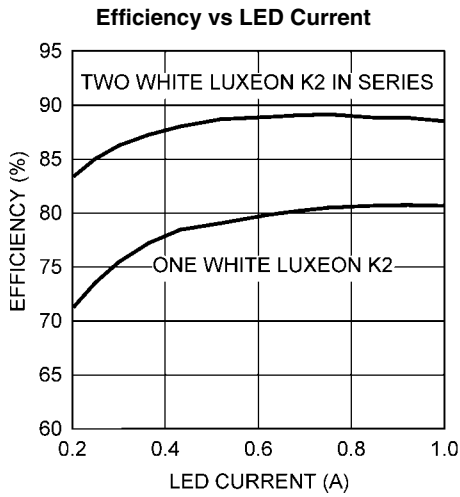

20178973

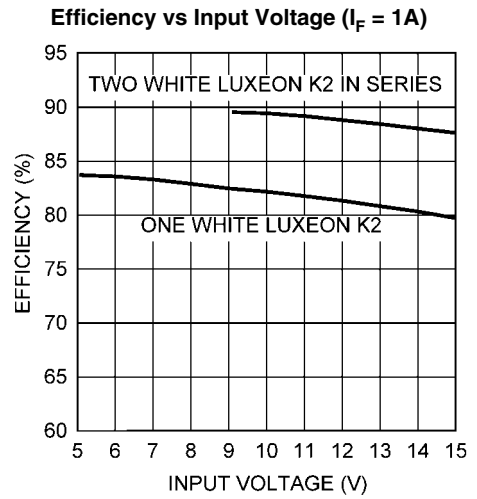

20178931

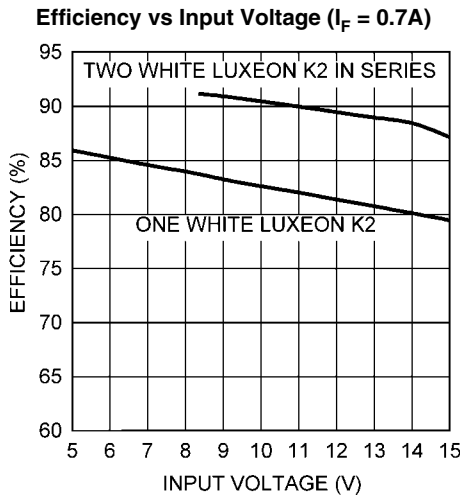

20178932

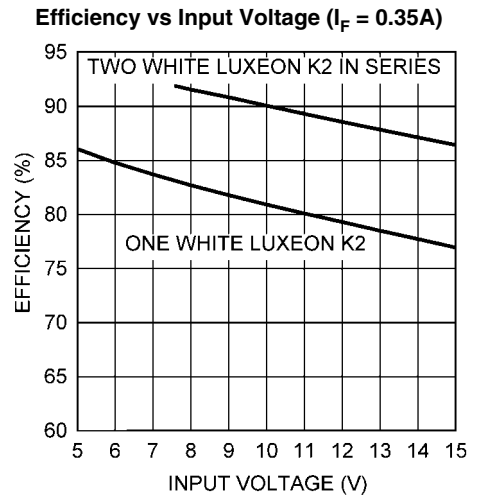

20178933

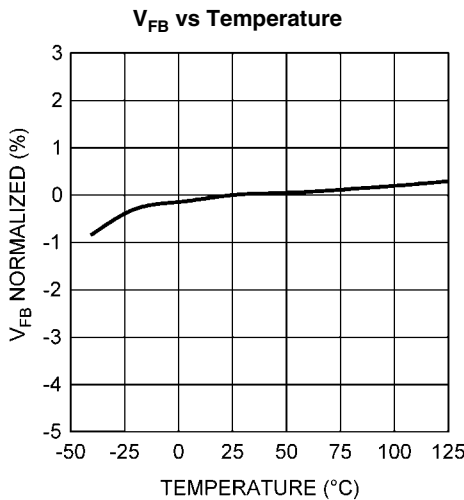

20178927

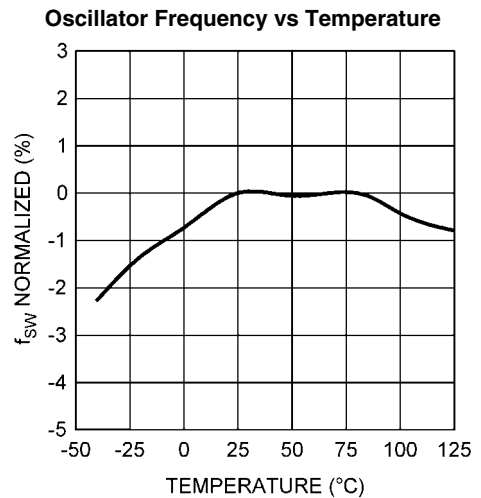

20178936

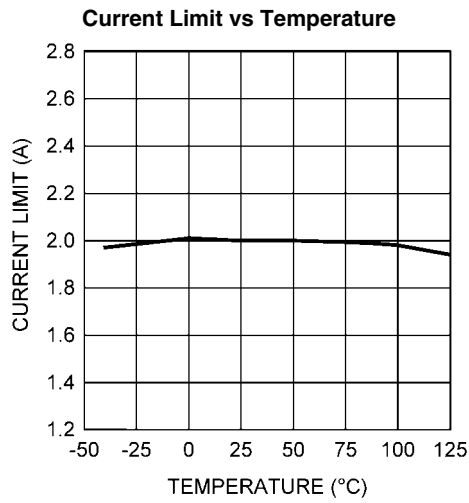

20178972

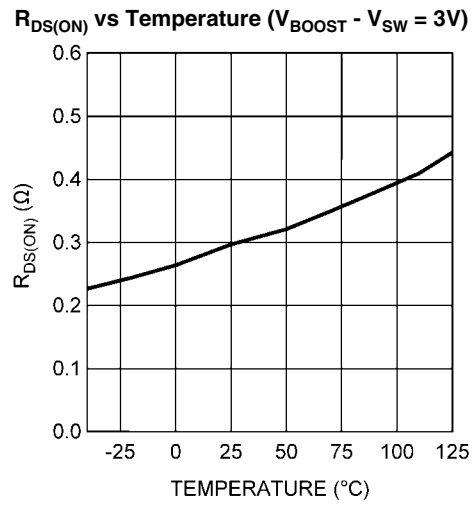

20178930

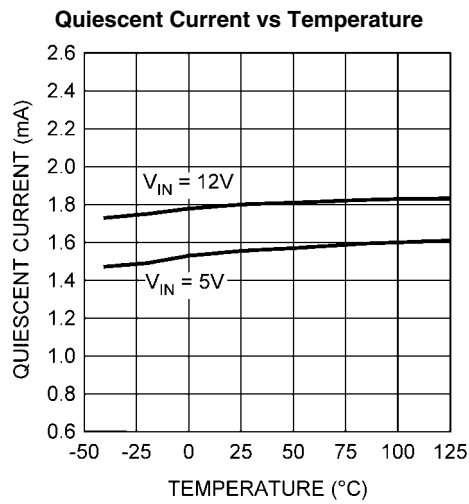

20178934

Startup Response to EN/DIM Signal ($V_{IN} = 15V, I_F = 0.2A$)

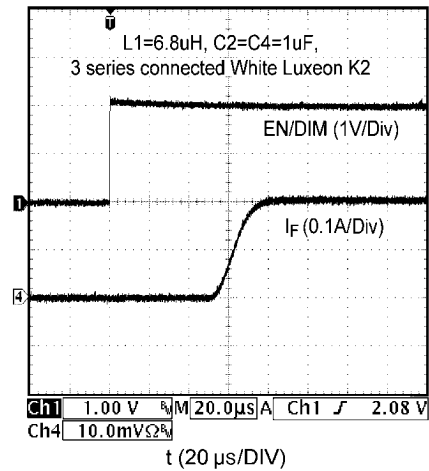

20178968

Block Diagram

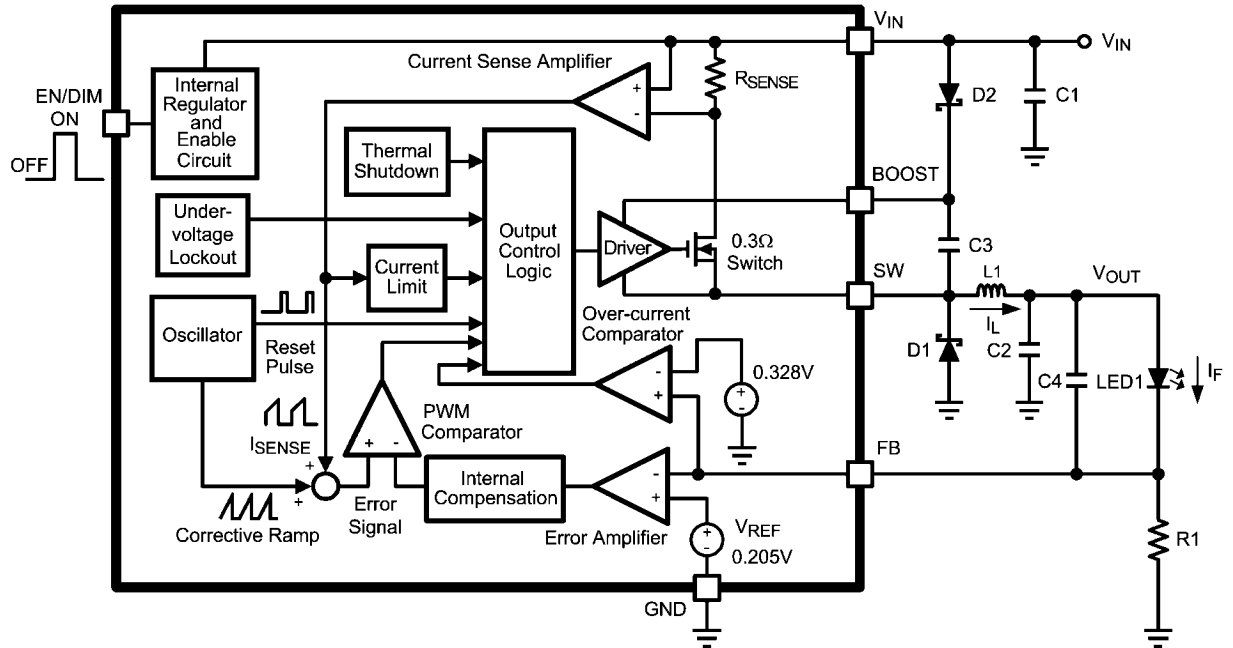

20178906

FIGURE 1. Simplified Block Diagram

Application Information

THEORY OF OPERATION

The LM3405 is a PWM, current-mode control switching buck regulator designed to provide a simple, high efficiency solution for driving LEDs with a preset switching frequency of 1.6MHz. This high frequency allows the LM3405 to operate with small surface mount capacitors and inductors, resulting in LED drivers that need only a minimum amount of board space. The LM3405 is internally compensated, simple to use, and requires few external components.

The following description of operation of the LM3405 will refer to the Simplified Block Diagram (Figure 1) and to the waveforms in Figure 2. The LM3405 supplies a regulated output current by switching the internal NMOS power switch at constant frequency and variable duty cycle. A switching cycle begins at the falling edge of the reset pulse generated by the internal oscillator. When this pulse goes low, the output control logic turns on the internal NMOS power switch. During this on-time, the SW pin voltage (V_{SW}) swings up to approximately V_{IN} , and the inductor current (I_L) increases with a linear slope. I_L is measured by the current sense amplifier, which generates an output proportional to the switch current. The sense signal is summed with the regulator's corrective ramp and compared to the error amplifier's output, which is proportional to the difference between the feedback voltage and V_{REF} . When the PWM comparator output goes high, the internal power switch turns off until the next switching cycle begins. During the switch off-time, inductor current discharges through the catch diode D1, which forces the SW pin to swing below ground by the forward voltage (V_{D1}) of the catch diode. The regulator loop adjusts the duty cycle (D) to maintain a constant output current (I_F) through the LED, by forcing FB pin voltage to be equal to V_{REF} (0.205V).

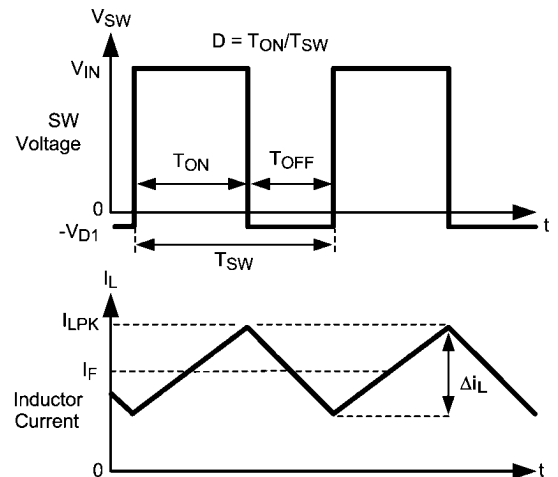

20178907

FIGURE 2. SW Pin Voltage and Inductor Current Waveforms of LM3405

BOOST FUNCTION

Capacitor C3 and diode D2 in Figure 1 are used to generate a voltage V_{BOOST} . The voltage across C3, $V_{BOOST} - V_{SW}$, is the gate drive voltage to the internal NMOS power switch. To properly drive the internal NMOS switch during its on-time, V_{BOOST} needs to be at least 2.5V greater than V_{SW} . Large value of $V_{BOOST} - V_{SW}$ is recommended to achieve better efficiency by minimizing both the internal switch ON resistance ($R_{DS(ON)}$), and the switch rise and fall times. However, $V_{BOOST} - V_{SW}$ should not exceed the maximum operating limit of 5.5V.

When the LM3405 starts up, internal circuitry from V_{IN} supplies a 20mA current to the BOOST pin, flowing out of the BOOST pin into C3. This current charges C3 to a voltage sufficient to turn the switch on. The BOOST pin will continue to source current to C3 until the voltage at the feedback pin is greater than 123mV.

There are various methods to derive V_{BOOST} :

1. From the input voltage (V_{IN})
2. From the output voltage (V_{OUT})
3. From a shunt or series zener diode
4. From an external distributed voltage rail (V_{EXT})

The first method is shown in the Simplified Block Diagram of Figure 1. Capacitor C3 is charged via diode D2 by V_{IN} . During a normal switching cycle, when the internal NMOS power switch is off (T_{OFF}) (refer to Figure 2), V_{BOOST} equals V_{IN} minus the forward voltage of D2 (V_{D2}), during which the current in the inductor (L1) forward biases the catch diode D1 (V_{D1}). Therefore the gate drive voltage stored across C3 is:

$$V_{BOOST} - V_{SW} = V_{IN} - V_{D2} + V_{D1}$$

When the NMOS switch turns on (T_{ON}), the switch pin rises to:

$$V_{SW} = V_{IN} - (R_{DS(ON)} \times I_L)$$

Since the voltage across C3 remains unchanged, V_{BOOST} is forced to rise thus reverse biasing D2. The voltage at V_{BOOST} is then:

$$V_{BOOST} = 2V_{IN} - (R_{DS(ON)} \times I_L) - V_{D2} + V_{D1}$$

Depending on the quality of the diodes D1 and D2, the gate drive voltage in this method can be slightly less or larger than the input voltage V_{IN} . For best performance, ensure that the variation of the input supply does not cause the gate drive voltage to fall outside the recommended range:

$$2.5V < V_{IN} - V_{D2} + V_{D1} < 5.5V$$

The second method for deriving the boost voltage is to connect D2 to the output as shown in Figure 3. The gate drive voltage in this configuration is:

$$V_{BOOST} - V_{SW} = V_{OUT} - V_{D2} + V_{D1}$$

Since the gate drive voltage needs to be in the range of 2.5V to 5.5V, the output voltage V_{OUT} should be limited to a certain range. For the calculation of V_{OUT} , see OUTPUT VOLTAGE section.

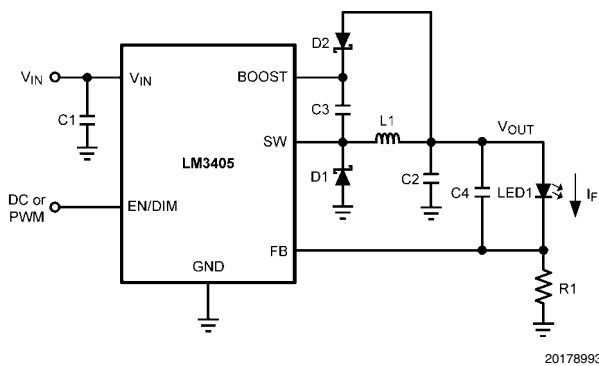

FIGURE 3. V_{BOOST} derived from V_{OUT}

The third method can be used in the applications where both V_{IN} and V_{OUT} are greater than 5.5V. In these cases, C3 cannot be charged directly from these voltages; instead C3 can be charged from V_{IN} or V_{OUT} minus a zener voltage (V_{D3}) by

placing a zener diode D3 in series with D2 as shown in Figure 4. When using a series zener diode from the input, the gate drive voltage is $V_{IN} - V_{D3} - V_{D2} + V_{D1}$.

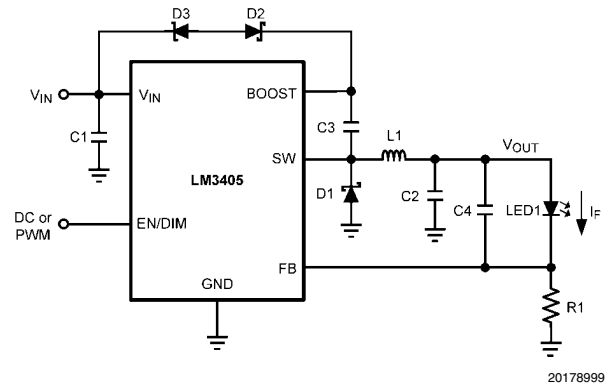

FIGURE 4. V_{BOOST} derived from V_{IN} through a Series Zener

An alternate method is to place the zener diode D3 in a shunt configuration as shown in Figure 5. A small 350mW to 500mW, 5.1V zener in a SOT-23 or SOD package can be used for this purpose. A small ceramic capacitor such as a 6.3V, 0.1µF capacitor (C5) should be placed in parallel with the zener diode. When the internal NMOS switch turns on, a pulse of current is drawn to charge the internal NMOS gate capacitance. The 0.1µF parallel shunt capacitor ensures that the V_{BOOST} voltage is maintained during this time. Resistor R2 should be chosen to provide enough RMS current to the zener diode and to the BOOST pin. A recommended choice for the zener current (I_{ZENER}) is 1mA. The current I_{BOOST} into the BOOST pin supplies the gate current of the NMOS power switch. It reaches a maximum of around 3.6mA at the highest gate drive voltage of 5.5V over the LM3405 operating range. For the worst case I_{BOOST} , increase the current by 50%. In that case, the maximum boost current will be:

$$I_{BOOST-MAX} = 1.5 \times 3.6mA = 5.4mA$$

R2 will then be given by:

$$R2 = (V_{IN} - V_{ZENER}) / (I_{BOOST-MAX} + I_{ZENER})$$

For example, let $V_{IN} = 12V$, $V_{ZENER} = 5V$, $I_{ZENER} = 1mA$, then:

$$R2 = (12V - 5V) / (5.4mA + 1mA) = 1.09k\Omega$$

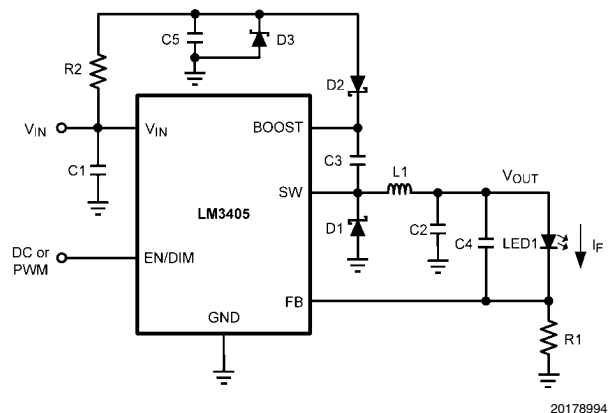

FIGURE 5. V_{BOOST} derived from V_{IN} through a Shunt Zener

The fourth method can be used in an application which has an external low voltage rail, V_{EXT} . C3 can be charged through D2 from V_{EXT} , independent of V_{IN} and V_{OUT} voltage levels. Again for best performance, ensure that the gate drive voltage, $V_{EXT} - V_{D2} + V_{D1}$, falls in the range of 2.5V to 5.5V.

SETTING THE LED CURRENT

LM3405 is a constant current buck regulator. The LEDs are connected between V_{OUT} and FB pin as shown in the Typical Application Circuit. The FB pin is at 0.205V in regulation and therefore the LED current I_F is set by V_{FB} and the resistor R1 from FB to ground by the following equation:

$$I_F = V_{FB} / R1$$

I_F should not exceed the 1A current capability of LM3405 and therefore R1 minimum must be approximately 0.2Ω. I_F should also be kept above 200mA for stable operation, and therefore R1 maximum must be approximately 1Ω. If average LED currents less than 200mA are desired, the EN/DIM pin can be used for PWM dimming. See LED PWM DIMMING section.

OUTPUT VOLTAGE

The output voltage is primarily determined by the number of LEDs (n) connected from V_{OUT} to FB pin and therefore V_{OUT} can be written as :

$$V_{OUT} = ((n \times V_F) + V_{FB})$$

where V_F is the forward voltage of one LED at the set LED current level (see LED manufacturer datasheet for forward characteristics curve).

ENABLE MODE / SHUTDOWN MODE

The LM3405 has both enable and shutdown modes that are controlled by the EN/DIM pin. Connecting a voltage source greater than 1.8V to the EN/DIM pin enables the operation of LM3405, while reducing this voltage below 0.4V places the part in a low quiescent current (0.3μA typical) shutdown mode. There is no internal pull-up on EN/DIM pin, therefore an external signal is required to initiate switching. Do not allow this pin to float or rise to 0.3V above V_{IN} . It should be noted that when the EN/DIM pin voltage rises above 1.8V while the input voltage is greater than UVLO, there is a finite delay before switching starts. During this delay the LM3405 will go through a power on reset state after which the internal soft-start process commences. The soft-start process limits the inrush current and brings up the LED current (I_F) in a smooth and controlled fashion. The total combined duration of the power on reset delay, soft-start delay and the delay to fully establish the LED current is in the order of 100μs (refer to *Figure 11*).

The simplest way to enable the operation of LM3405 is to connect the EN/DIM pin to V_{IN} which allows self start-up of LM3405 whenever the input voltage is applied. However, when an input voltage of slow rise time is used to power the application and if both the input voltage and the output voltage are not fully established before the soft-start time elapses, the control circuit will command maximum duty cycle operation of the internal power switch to bring up the output voltage rapidly. When the feedback pin voltage exceeds 0.205V, the duty cycle will have to reduce from the maximum value accordingly, to maintain regulation. It takes a finite amount of time for this reduction of duty cycle and this will result in a spike in LED current for a short duration as shown in *Figure 6*. In applications where this LED current overshoot is undesirable, EN/DIM pin voltage can be delayed with respect to V_{IN} such that V_{IN} is fully established before the EN/DIM pin voltage reaches the enable threshold. This delay can be implemented by a simple R_a - C_a network as shown in *Figure 7*. The effect of

adding this R_a - C_a network on the LED current is shown in *Figure 8*. For a fast rising input voltage (200μs for example), there is no need to delay the EN/DIM signal since soft-start can smoothly bring up the LED current as shown in *Figure 9*.

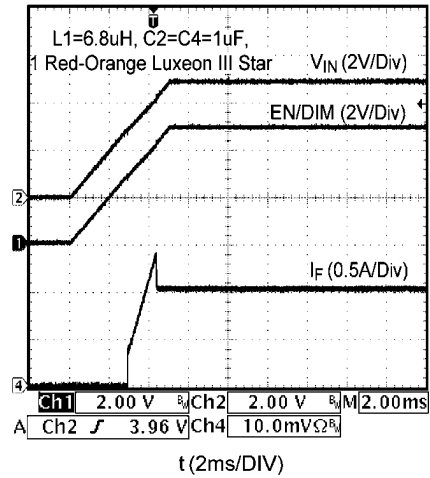

FIGURE 6. Startup Response to V_{IN} with 5ms rise time

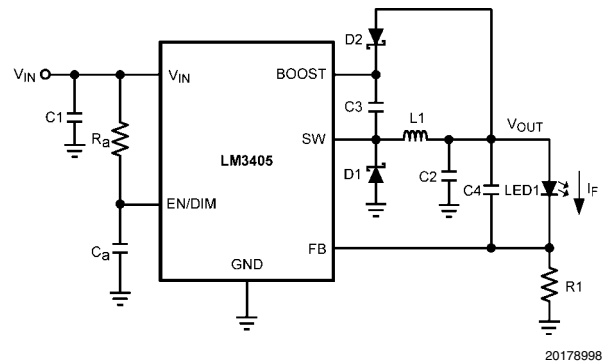

FIGURE 7. EN/DIM delayed with respect to V_{IN}

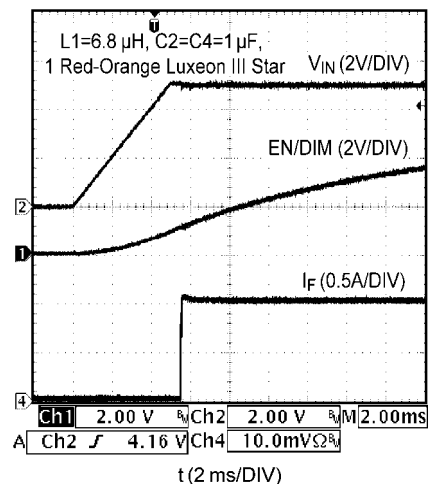
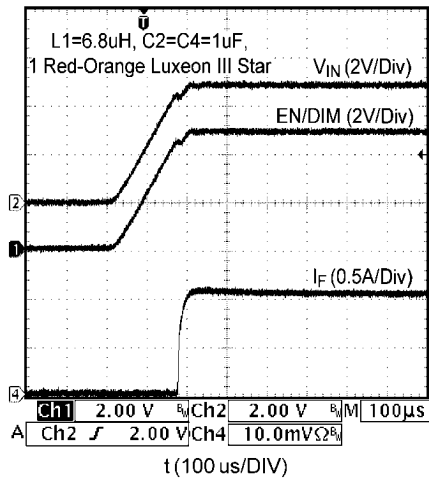
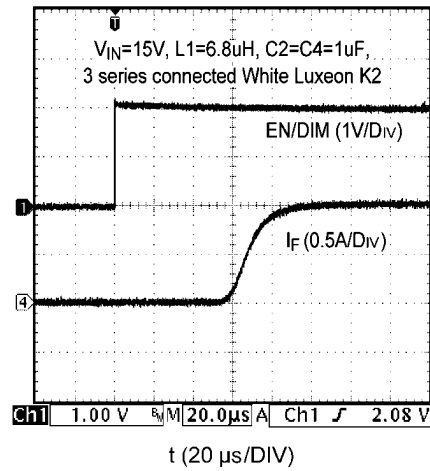

FIGURE 8. Startup Response to V_{IN} with EN/DIM delayed



20178975

FIGURE 9. Startup Response to V_{IN} with 200µs rise time



20178967

FIGURE 11. Startup Response to EN/DIM with $I_F = 1A$

LED PWM DIMMING

The LED brightness can be controlled by applying a periodic pulse signal to the EN/DIM pin and varying its frequency and/or duty cycle. This so-called PWM dimming method controls the average light output by pulsing the LED current between the set value and zero. A logic high level at the EN/DIM pin turns on the LED current whereas a logic low level turns off the LED current. *Figure 10* shows a typical LED current waveform in PWM dimming mode. As explained in the previous section, there is approximately a 100µs delay from the EN/DIM signal going high to fully establishing the LED current as shown in *Figure 11*. This 100µs delay sets a maximum frequency limit for the driving signal that can be applied to the EN/DIM pin for PWM dimming. *Figure 12* shows the average LED current versus duty cycle of PWM dimming signal for various frequencies. The applicable frequency range to drive LM3405 for PWM dimming is from 100Hz to 5kHz. The dimming ratio reduces drastically when the applied PWM dimming frequency is greater than 5kHz.

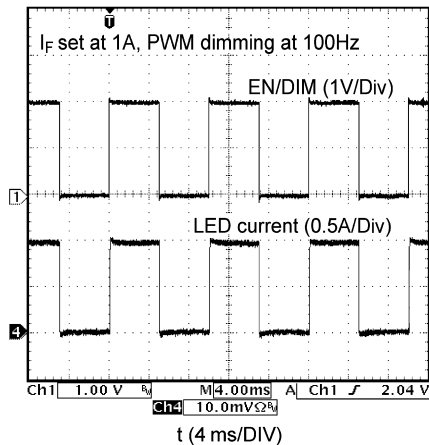

20178966

FIGURE 10. PWM Dimming of LEDs using the EN/DIM Pin

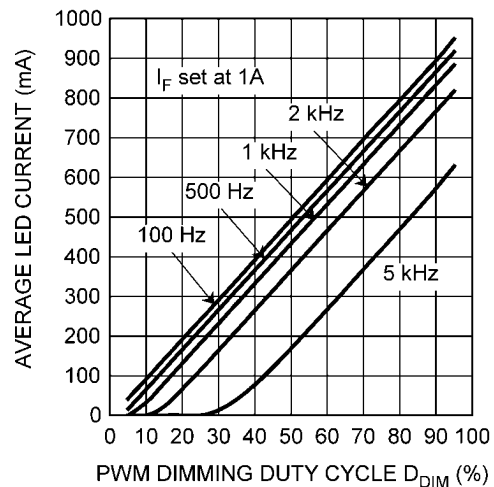

20178983

FIGURE 12. Average LED Current versus Duty Cycle of PWM Dimming Signal at EN/DIM Pin

UNDER-VOLTAGE LOCKOUT

Under-voltage lockout (UVLO) prevents the LM3405 from operating until the input voltage exceeds 2.74V (typical). The UVLO threshold has approximately 440mV of hysteresis, so the part will operate until V_{IN} drops below 2.3V (typical). Hysteresis prevents the part from turning off during power up if V_{IN} is non-monotonic.

CURRENT LIMIT

The LM3405 uses cycle-by-cycle current limit to protect the internal power switch. During each switching cycle, a current limit comparator detects if the power switch current exceeds 2.0A (typical), and turns off the switch until the next switching cycle begins.

OVER-CURRENT PROTECTION

The LM3405 has a built in over-current comparator that compares the FB pin voltage to a threshold voltage that is 60% higher than the internal reference V_{REF} . Once the FB pin voltage exceeds this threshold level (typically 328mV), the internal NMOS power switch is turned off, which allows the feedback voltage to decrease towards regulation. This

threshold provides an upper limit for the LED current. LED current overshoot is limited to $328\text{mV}/R_1$ by this comparator during transients.

THERMAL SHUTDOWN

Thermal shutdown limits total power dissipation by turning off the internal power switch when the IC junction temperature exceeds 165°C . After thermal shutdown occurs, the power switch does not turn on until the junction temperature drops below approximately 150°C .

Design Guide

INDUCTOR (L1)

The Duty Cycle (D) can be approximated quickly using the ratio of output voltage (V_{OUT}) to input voltage (V_{IN}):

$$D = \frac{V_{\text{OUT}}}{V_{\text{IN}}}$$

The catch diode (D1) forward voltage drop and the voltage drop across the internal NMOS must be included to calculate a more accurate duty cycle. Calculate D by using the following formula:

$$D = \frac{V_{\text{OUT}} + V_{\text{D1}}}{V_{\text{IN}} + V_{\text{D1}} - V_{\text{SW}}}$$

V_{SW} can be approximated by:

$$V_{\text{SW}} = I_{\text{F}} \times R_{\text{DS(ON)}}$$

The diode forward drop (V_{D1}) can range from 0.3V to 0.7V depending on the quality of the diode. The lower V_{D1} is, the higher the operating efficiency of the converter.

The inductor value determines the output ripple current (Δi_{L} , as defined in *Figure 2*). Lower inductor values decrease the size of the inductor, but increases the output ripple current. An increase in the inductor value will decrease the output ripple current. The ratio of ripple current to LED current is optimized when it is set between 0.3 and 0.4 at 1A LED current. This ratio r is defined as:

$$r = \frac{\Delta i_{\text{L}}}{I_{\text{F}}}$$

One must also ensure that the minimum current limit (1.2A) is not exceeded, so the peak current in the inductor must be calculated. The peak current (I_{LPK}) in the inductor is calculated as:

$$I_{\text{LPK}} = I_{\text{F}} + \Delta i_{\text{L}}/2$$

When the designed maximum output current is reduced, the ratio r can be increased. At a current of 0.2A, r can be made as high as 0.7. The ripple ratio can be increased at lighter loads because the net ripple is actually quite low, and if r remains constant the inductor value can be made quite large. An equation empirically developed for the maximum ripple ratio at any current below 2A is:

$$r = 0.387 \times I_{\text{OUT}}^{-0.3667}$$

Note that this is just a guideline.

The LM3405 operates at a high frequency allowing the use of ceramic output capacitors without compromising transient re-

sponse. Ceramic capacitors allow higher inductor ripple without significantly increasing LED current ripple. See the output capacitor and feed-forward capacitor sections for more details on LED current ripple.

Now that the ripple current or ripple ratio is determined, the inductance is calculated by:

$$L = \frac{V_{\text{OUT}} + V_{\text{D1}}}{I_{\text{F}} \times r \times f_{\text{SW}}} \times (1-D)$$

where f_{SW} is the switching frequency and I_{F} is the LED current. When selecting an inductor, make sure that it is capable of supporting the peak output current without saturating. Inductor saturation will result in a sudden reduction in inductance and prevent the regulator from operating correctly. Because of the operating frequency of LM3405, ferrite based inductors are preferred to minimize core losses. This presents little restriction since the variety of ferrite based inductors is huge. Lastly, inductors with lower series resistance (DCR) will provide better operating efficiency. For recommended inductor selection, refer to Circuit Examples and Recommended Inductance Range in *Table 1*. Note that it is a good practice to use small inductance value at light load (for example, $I_{\text{F}} = 0.2\text{A}$) to increase inductor current ramp signal, such that noise immunity is improved.

TABLE 1. Recommended Inductance Range

I_{F}	Inductance Range and Inductor Current Ripple			
1.0A	4.7μH-10μH			
	Inductance	4.7μH	6.8μH	10μH
	$\Delta i_{\text{L}} / I_{\text{F}}^*$	51%	35%	24%
0.6A	6.8μH-15μH			
	Inductance	6.8μH	10μH	15μH
	$\Delta i_{\text{L}} / I_{\text{F}}^*$	58%	40%	26%
0.2A	4.7μH**-22μH			
	Inductance	10μH	15μH	22μH
	$\Delta i_{\text{L}} / I_{\text{F}}^*$	119%	79%	54%

*Maximum over full range of V_{IN} and V_{OUT} .

**Small inductance improves stability without causing a significant increase in LED current ripple.

INPUT CAPACITOR (C1)

An input capacitor is necessary to ensure that V_{IN} does not drop excessively during switching transients. The primary specifications of the input capacitor are capacitance, voltage rating, RMS current rating, and ESL (Equivalent Series Inductance). The input voltage rating is specifically stated by the capacitor manufacturer. Make sure to check any recommended deratings and also verify if there is any significant change in capacitance at the operating input voltage and the operating temperature. The input capacitor maximum RMS input current rating ($I_{\text{RMS-IN}}$) must be greater than:

$$I_{\text{RMS-IN}} = I_{\text{F}} \times \sqrt{D \times \left(1 - D + \frac{r^2}{12}\right)}$$

It can be shown from the above equation that maximum RMS capacitor current occurs when $D = 0.5$. Always calculate the RMS at the point where the duty cycle D , is closest to 0.5. The ESL of an input capacitor is usually determined by the effective cross sectional area of the current path. A large leaded

capacitor will have high ESL and a 0805 ceramic chip capacitor will have very low ESL. At the operating frequency of the LM3405, certain capacitors may have an ESL so large that the resulting inductive impedance ($2\pi fL$) will be higher than that required to provide stable operation. It is strongly recommended to use ceramic capacitors due to their low ESR and low ESL. A $10\mu\text{F}$ multilayer ceramic capacitor (MLCC) is a good choice for most applications. In cases where large capacitance is required, use surface mount capacitors such as Tantalum capacitors and place at least a $1\mu\text{F}$ ceramic capacitor close to the V_{IN} pin. For MLCCs it is recommended to use X7R or X5R dielectrics. Consult capacitor manufacturer datasheet to see how rated capacitance varies over operating conditions.

OUTPUT CAPACITOR (C2)

The output capacitor is selected based upon the desired reduction in LED current ripple. A $1\mu\text{F}$ ceramic capacitor results in very low LED current ripple for most applications. Due to the high switching frequency, the $1\mu\text{F}$ capacitor alone (without feed-forward capacitor C4) can filter more than 90% of the inductor current ripple for most applications where the sum of LED dynamic resistance and R_1 is larger than 1Ω . Since the internal compensation is tailored for small output capacitance with very low ESR, it is strongly recommended to use a ceramic capacitor with capacitance less than $3.3\mu\text{F}$.

Given the availability and quality of MLCCs and the expected output voltage of designs using the LM3405, there is really no need to review other capacitor technologies. A benefit of ceramic capacitors is their ability to bypass high frequency noise. A certain amount of switching edge noise will couple through the parasitic capacitances in the inductor to the output. A ceramic capacitor will bypass this noise. In cases where large capacitance is required, use Electrolytic or Tantalum capacitors with large ESR, and verify the loop performance on bench. Like the input capacitor, recommended multilayer ceramic capacitors are X7R or X5R. Again, verify actual capacitance at the desired operating voltage and temperature. Check the RMS current rating of the capacitor. The maximum RMS current rating of the capacitor is:

$$I_{\text{RMS-OUT}} = I_{\text{F}} \times \frac{r}{\sqrt{12}}$$

One may select a 1206 size ceramic capacitor for C2, since its current rating is typically higher than 1A, more than enough for the requirement.

FEED-FORWARD CAPACITOR (C4)

The feed-forward capacitor (designated as C4) connected in parallel with the LED string is required to provide multiple benefits to the LED driver design. It greatly improves the large signal transient response and suppresses LED current overshoot that may otherwise occur during PWM dimming; it also helps to shape the rise and fall times of the LED current pulse during PWM dimming thus reducing EMI emission; it reduces LED current ripple by bypassing some of inductor ripple from flowing through the LED. For most applications, a $1\mu\text{F}$ ceramic capacitor is sufficient. In fact, the combination of a $1\mu\text{F}$ feed-forward ceramic capacitor and a $1\mu\text{F}$ output ceramic capacitor leads to less than 1% current ripple flowing through the LED. Lower and higher C4 values can be used, but bench validation is required to ensure the performance meets the application requirement.

Figure 13 shows a typical LED current waveform during PWM dimming without feed-forward capacitor. At the beginning of

each PWM cycle, overshoot can be seen in the LED current. Adding a $1\mu\text{F}$ feed-forward capacitor can totally remove the overshoot as shown in Figure 14.

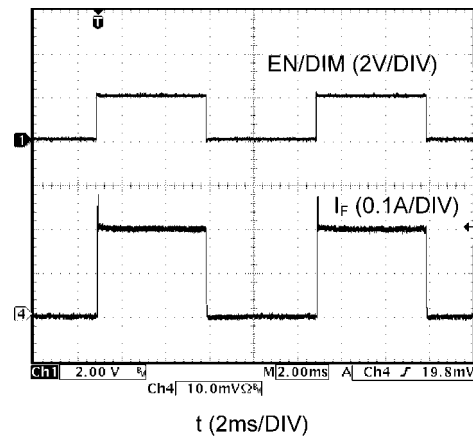

FIGURE 13. PWM Dimming without Feed-Forward Capacitor

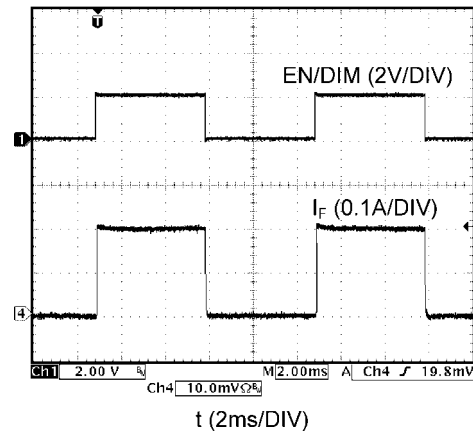

FIGURE 14. PWM Dimming with a $1\mu\text{F}$ Feed-Forward Capacitor

CATCH DIODE (D1)

The catch diode (D1) conducts during the switch off-time. A Schottky diode is required for its fast switching time and low forward voltage drop. The catch diode should be chosen such that its current rating is greater than:

$$I_{\text{D1}} = I_{\text{F}} \times (1-D)$$

The reverse breakdown rating of the diode must be at least the maximum input voltage plus appropriate margin. To improve efficiency, choose a Schottky diode with a low forward voltage drop.

BOOST DIODE (D2)

A standard diode such as the 1N4148 type is recommended. For V_{BOOST} circuits derived from voltages less than 3.3V, a small-signal Schottky diode is recommended for better efficiency. A good choice is the BAT54 small signal diode.

BOOST CAPACITOR (C3)

A 0.01 μ F ceramic capacitor with a voltage rating of at least 6.3V is sufficient. The X7R and X5R MLCCs provide the best performance.

POWER LOSS ESTIMATION

The main power loss in LM3405 includes three basic types of loss in the internal power switch: conduction loss, switching loss, and gate charge loss. In addition, there is loss associated with the power required for the internal circuitry of IC.

The conduction loss is calculated as:

$$P_{\text{COND}} = (I_F^2 \times D) \times \left(1 + \frac{1}{3} \times \left(\frac{\Delta I_L}{I_F} \right)^2 \right) \times R_{\text{DS(ON)}}$$

If the inductor ripple current is fairly small (for example, less than 40%), the conduction loss can be simplified to:

$$P_{\text{COND}} = I_F^2 \times R_{\text{DS(ON)}} \times D$$

The switching loss occurs during the switch on and off transition periods, where voltage and current overlap resulting in power loss. The simplest means to determine this loss is to empirically measure the rise and fall times (10% to 90%) of the voltage at the switch pin.

Switching power loss is calculated as follows:

$$P_{\text{SW}} = 0.5 \times V_{\text{IN}} \times I_F \times f_{\text{SW}} \times (T_{\text{RISE}} + T_{\text{FALL}})$$

The gate charge loss is associated with the gate charge Q_G required to drive the switch:

$$P_G = f_{\text{SW}} \times V_{\text{IN}} \times Q_G$$

The power loss required for operation of the internal circuitry:

$$P_Q = I_Q \times V_{\text{IN}}$$

I_Q is the quiescent operating current, and is typically around 1.8mA for the LM3405.

The total power loss in the IC is:

$$P_{\text{INTERNAL}} = P_{\text{COND}} + P_{\text{SW}} + P_G + P_Q$$

An example of power losses for a typical application is shown in *Table 2*:

TABLE 2. Power Loss Tabulation

Conditions		Power loss	
V_{IN}	12V		
V_{OUT}	4.1V		
I_{OUT}	1.0A		
V_{D1}	0.45V		
$R_{\text{DS(ON)}}$	300m Ω	P_{COND}	111mW
f_{SW}	1.6MHz		
T_{RISE}	18ns	P_{SW}	288mW
T_{FALL}	12ns		
I_Q	1.8mA	P_Q	22mW
Q_G	1.4nC	P_G	27mW
D is calculated to be 0.37			

$$\Sigma (P_{\text{COND}} + P_{\text{SW}} + P_Q + P_G) = P_{\text{INTERNAL}}$$

$$P_{\text{INTERNAL}} = 448\text{mW}$$

PCB Layout Considerations

When planning layout there are a few things to consider when trying to achieve a clean, regulated output. The most important consideration when completing the layout is the close coupling of the GND connections of the input capacitor C1 and the catch diode D1. These ground ends should be close to one another and be connected to the GND plane with at least two through-holes. Place these components as close to the IC as possible. The next consideration is the location of the GND connection of the output capacitor C2, which should be near the GND connections of C1 and D1.

There should be a continuous ground plane on the bottom layer of a two-layer board except under the switching node island.

The FB pin is a high impedance node and care should be taken to make the FB trace short to avoid noise pickup that causes inaccurate regulation. The LED current setting resistor R1 should be placed as close as possible to the IC, with the GND of R1 placed as close as possible to the GND of the IC. The V_{OUT} trace to LED anode should be routed away from the inductor and any other traces that are switching.

High AC currents flow through the V_{IN} , SW and V_{OUT} traces, so they should be as short and wide as possible. Radiated noise can be decreased by choosing a shielded inductor.

The remaining components should also be placed as close as possible to the IC. Please see Application Note AN-1229 for further considerations and the LM3405 demo board as an example of a four-layer layout.

LM3405 Circuit Examples

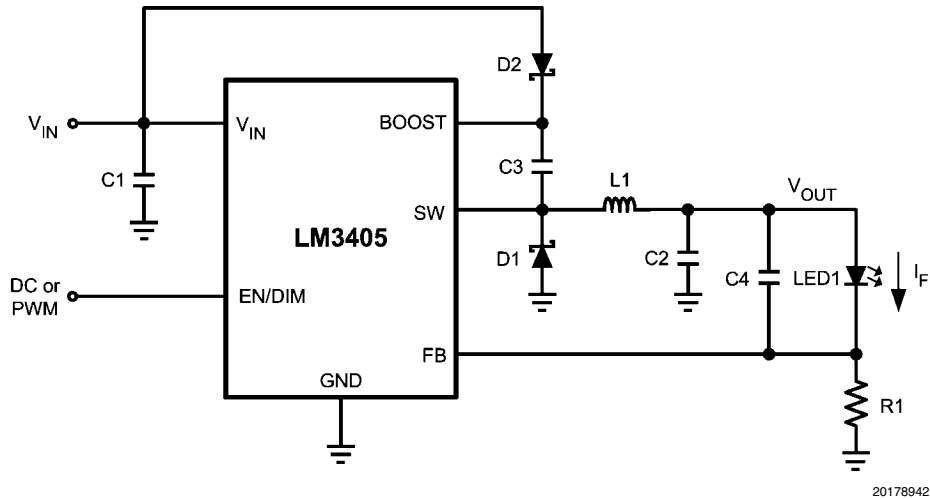
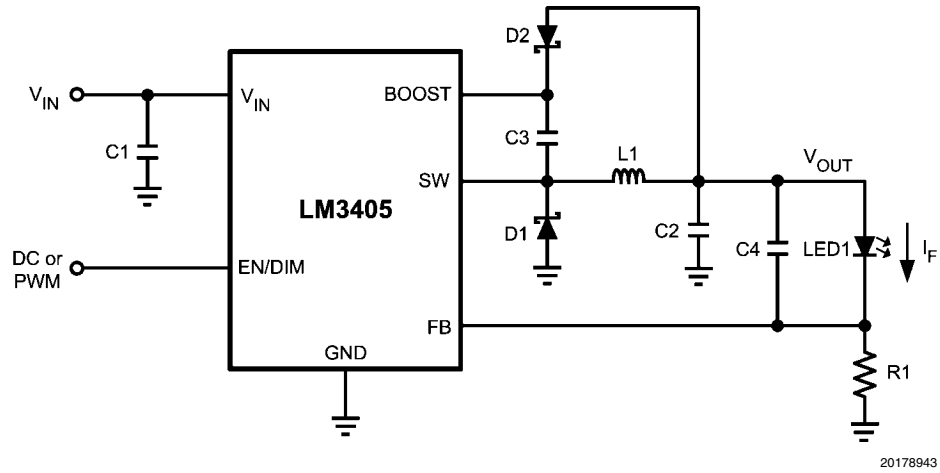

FIGURE 15. V_{BOOST} derived from V_{IN}
 ($V_{\text{IN}} = 5\text{V}$, $I_{\text{F}} = 1\text{A}$)

Bill of Materials for Figure 15

Part ID	Part Value	Part Number	Manufacturer
U1	1A LED Driver	LM3405	National Semiconductor
C1, Input Cap	10µF, 6.3V, X5R	C3216X5R0J106M	TDK
C2, Output Cap	1µF, 10V, X7R	GRM319R71A105KC01D	Murata
C3, Boost Cap	0.01µF, 16V, X7R	0805YC103KAT2A	AVX
C4, Feedforward Cap	1µF, 10V, X7R	GRM319R71A105KC01D	Murata
D1, Catch Diode	Schottky, 0.37V at 1A, $V_{\text{R}} = 10\text{V}$	MBRM110LT1G	ON Semiconductor
D2, Boost Diode	Schottky, 0.36V at 15mA	CMDSH-3	Central Semiconductor
L1	4.7µH, 1.6A	SLF6028T-4R7M1R6	TDK
R1	0.2Ω, 0.5W, 1%	WSL2010R2000FEA	Vishay
LED1	1A, White LED	LXHL-PW09	Lumileds



20178943

FIGURE 16. V_{BOOST} derived from V_{OUT}
 ($V_{IN} = 12V$, $I_F = 1A$)

Bill of Materials for Figure 16

Part ID	Part Value	Part Number	Manufacturer
U1	1A LED Driver	LM3405	National Semiconductor
C1, Input Cap	10 μ F, 25V, X5R	ECJ-3YB1E106K	Panasonic
C2, Output Cap	1 μ F, 10V, X7R	GRM319R71A105KC01D	Murata
C3, Boost Cap	0.01 μ F, 16V, X7R	0805YC103KAT2A	AVX
C4, Feedforward Cap	1 μ F, 10V, X7R	GRM319R71A105KC01D	Murata
D1, Catch Diode	Schottky, 0.5V at 1A, $V_R = 30V$	SS13	Vishay
D2, Boost Diode	Schottky, 0.36V at 15mA	CMDSH-3	Central Semiconductor
L1	4.7 μ H, 1.6A	SLF6028T-4R7M1R6	TDK
R1	0.2 Ω , 0.5W, 1%	WSL2010R2000FEA	Vishay
LED1	1A, White LED	LXHL-PW09	Lumileds

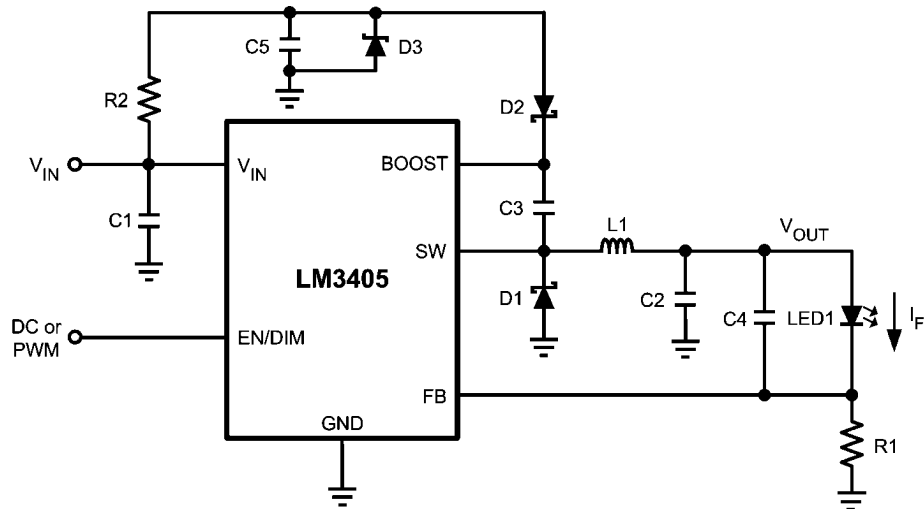

20178944

FIGURE 17. V_{BOOST} derived from V_{IN} through a Shunt Zener Diode (D3)
($V_{IN} = 15V$, $I_F = 1A$)

Bill of Materials for Figure 17

Part ID	Part Value	Part Number	Manufacturer
U1	1A LED Driver	LM3405	National Semiconductor
C1, Input Cap	10 μ F, 25V, X5R	ECJ-3YB1E106K	Panasonic
C2, Output Cap	1 μ F, 10V, X7R	GRM319R71A105KC01D	Murata
C3, Boost Cap	0.01 μ F, 16V, X7R	0805YC103KAT2A	AVX
C4, Feedforward Cap	1 μ F, 10V, X7R	GRM319R71A105KC01D	Murata
C5, Shunt Cap	0.1 μ F, 16V, X7R	GRM219R71C104KA01D	Murata
D1, Catch Diode	Schottky, 0.5V at 1A, $V_R = 30V$	SS13	Vishay
D2, Boost Diode	Schottky, 0.36V at 15mA	CMDSH-3	Central Semiconductor
D3, Zener Diode	4.7V, 350mW, SOT-23	BZX84C4V7	Fairchild
L1	6.8 μ H, 1.5A	SLF6028T-6R8M1R5	TDK
R1	0.2 Ω , 0.5W, 1%	WSL2010R2000FEA	Vishay
R2	1.91k Ω , 1%	CRCW08051K91FKEA	Vishay
LED1	1A, White LED	LXHL-PW09	Lumileds

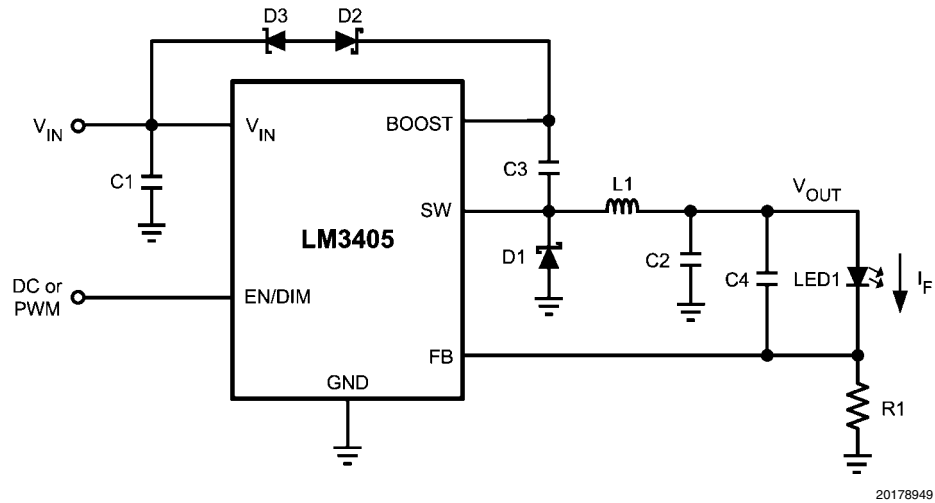

20178949

FIGURE 18. V_{BOOST} derived from V_{IN} through a Series Zener Diode (D3)
 ($V_{IN} = 15V$, $I_F = 1A$)

Bill of Materials for Figure 18

Part ID	Part Value	Part Number	Manufacturer
U1	1A LED Driver	LM3405	National Semiconductor
C1, Input Cap	10 μ F, 25V, X5R	ECJ-3YB1E106K	Panasonic
C2, Output Cap	1 μ F, 10V, X7R	GRM319R71A105KC01D	Murata
C3, Boost Cap	0.01 μ F, 16V, X7R	0805YC103KAT2A	AVX
C4, Feedforward Cap	1 μ F, 10V, X7R	GRM319R71A105KC01D	Murata
D1, Catch Diode	Schottky, 0.5V at 1A, $V_R = 30V$	SS13	Vishay
D2, Boost Diode	Schottky, 0.36V at 15mA	CMDSH-3	Central Semiconductor
D3, Zener Diode	11V, 350mW, SOT-23	BZX84C11	Fairchild
L1	6.8 μ H, 1.5A	SLF6028T-6R8M1R5	TDK
R1	0.2 Ω , 0.5W, 1%	WSL2010R2000FEA	Vishay
LED1	1A, White LED	LXHL-PW09	Lumileds

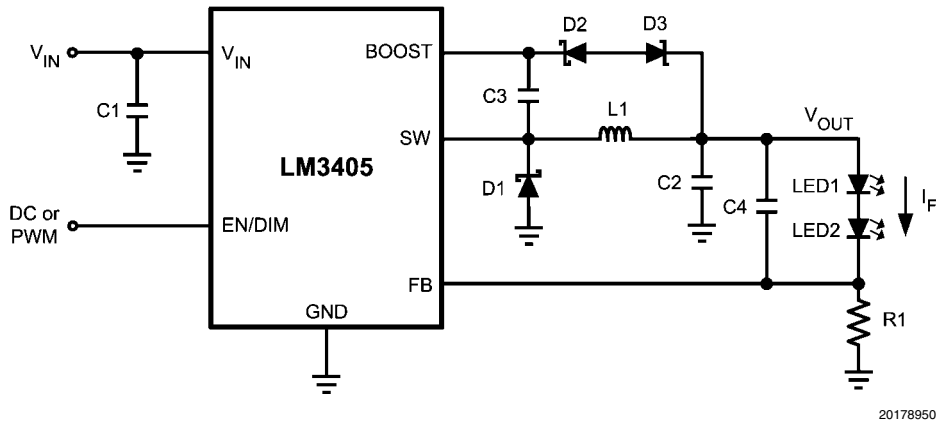

20178950

**FIGURE 19. V_{BOOST} derived from V_{OUT} through a Series Zener Diode (D3)
($V_{IN} = 15V$, $I_F = 1A$)**

Bill of Materials for Figure 19

Part ID	Part Value	Part Number	Manufacturer
U1	1A LED Driver	LM3405	National Semiconductor
C1, Input Cap	10 μ F, 25V, X5R	ECJ-3YB1E106K	Panasonic
C2, Output Cap	1 μ F, 16V, X7R	GRM319R71A105KC01D	Murata
C3, Boost Cap	0.01 μ F, 16V, X7R	0805YC103KAT2A	AVX
C4, Feedforward Cap	1 μ F, 16V, X7R	GRM319R71A105KC01D	Murata
D1, Catch Diode	Schottky, 0.5V at 1A, $V_R = 30V$	SS13	Vishay
D2, Boost Diode	Schottky, 0.36V at 15mA	CMDSH-3	Central Semiconductor
D3, Zener Diode	3.9V, 350mW, SOT-23	BZX84C3V9	Fairchild
L1	6.8 μ H, 1.5A	SLF6028T-6R8M1R5	TDK
R1	0.2 Ω , 0.5W, 1%	WSL2010R2000FEA	Vishay
LED1	1A, White LED	LXHL-PW09	Lumileds
LED2	1A, White LED	LXHL-PW09	Lumileds

Physical Dimensions inches (millimeters) unless otherwise noted

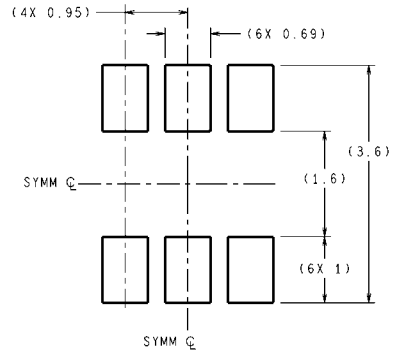
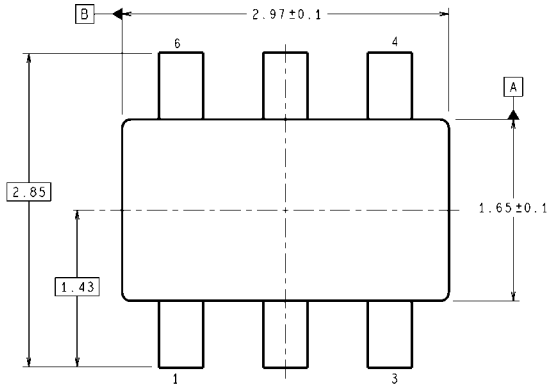

RECOMMENDED LAND PATTERN

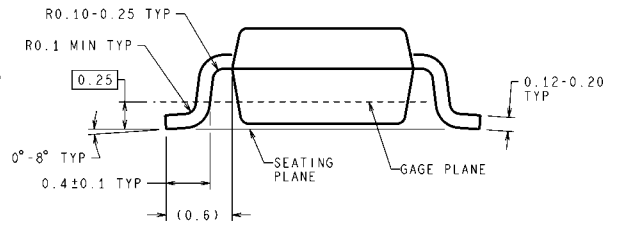
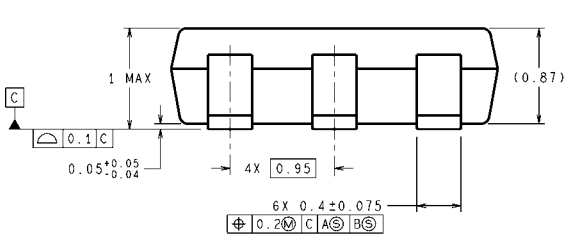

DIMENSIONS ARE IN MILLIMETERS

**6-Lead TSOT Package
NS Package Number MK06A**

MK06A (Rev D)

Notes

Notes

THE CONTENTS OF THIS DOCUMENT ARE PROVIDED IN CONNECTION WITH NATIONAL SEMICONDUCTOR CORPORATION ("NATIONAL") PRODUCTS. NATIONAL MAKES NO REPRESENTATIONS OR WARRANTIES WITH RESPECT TO THE ACCURACY OR COMPLETENESS OF THE CONTENTS OF THIS PUBLICATION AND RESERVES THE RIGHT TO MAKE CHANGES TO SPECIFICATIONS AND PRODUCT DESCRIPTIONS AT ANY TIME WITHOUT NOTICE. NO LICENSE, WHETHER EXPRESS, IMPLIED, ARISING BY ESTOPPEL OR OTHERWISE, TO ANY INTELLECTUAL PROPERTY RIGHTS IS GRANTED BY THIS DOCUMENT.

TESTING AND OTHER QUALITY CONTROLS ARE USED TO THE EXTENT NATIONAL DEEMS NECESSARY TO SUPPORT NATIONAL'S PRODUCT WARRANTY. EXCEPT WHERE MANDATED BY GOVERNMENT REQUIREMENTS, TESTING OF ALL PARAMETERS OF EACH PRODUCT IS NOT NECESSARILY PERFORMED. NATIONAL ASSUMES NO LIABILITY FOR APPLICATIONS ASSISTANCE OR BUYER PRODUCT DESIGN. BUYERS ARE RESPONSIBLE FOR THEIR PRODUCTS AND APPLICATIONS USING NATIONAL COMPONENTS. PRIOR TO USING OR DISTRIBUTING ANY PRODUCTS THAT INCLUDE NATIONAL COMPONENTS, BUYERS SHOULD PROVIDE ADEQUATE DESIGN, TESTING AND OPERATING SAFEGUARDS.

EXCEPT AS PROVIDED IN NATIONAL'S TERMS AND CONDITIONS OF SALE FOR SUCH PRODUCTS, NATIONAL ASSUMES NO LIABILITY WHATSOEVER, AND NATIONAL DISCLAIMS ANY EXPRESS OR IMPLIED WARRANTY RELATING TO THE SALE AND/OR USE OF NATIONAL PRODUCTS INCLUDING LIABILITY OR WARRANTIES RELATING TO FITNESS FOR A PARTICULAR PURPOSE, MERCHANTABILITY, OR INFRINGEMENT OF ANY PATENT, COPYRIGHT OR OTHER INTELLECTUAL PROPERTY RIGHT.

LIFE SUPPORT POLICY

NATIONAL'S PRODUCTS ARE NOT AUTHORIZED FOR USE AS CRITICAL COMPONENTS IN LIFE SUPPORT DEVICES OR SYSTEMS WITHOUT THE EXPRESS PRIOR WRITTEN APPROVAL OF THE CHIEF EXECUTIVE OFFICER AND GENERAL COUNSEL OF NATIONAL SEMICONDUCTOR CORPORATION. As used herein:

Life support devices or systems are devices which (a) are intended for surgical implant into the body, or (b) support or sustain life and whose failure to perform when properly used in accordance with instructions for use provided in the labeling can be reasonably expected to result in a significant injury to the user. A critical component is any component in a life support device or system whose failure to perform can be reasonably expected to cause the failure of the life support device or system or to affect its safety or effectiveness.

National Semiconductor and the National Semiconductor logo are registered trademarks of National Semiconductor Corporation. All other brand or product names may be trademarks or registered trademarks of their respective holders.

Copyright© 2007 National Semiconductor Corporation

For the most current product information visit us at www.national.com



**National Semiconductor
Americas Customer
Support Center**
Email:
new.feedback@nsc.com
Tel: 1-800-272-9959

**National Semiconductor Europe
Customer Support Center**
Fax: +49 (0) 180-530-85-86
Email: europe.support@nsc.com
Deutsch Tel: +49 (0) 69 9508 6208
English Tel: +49 (0) 870 24 0 2171
Français Tel: +33 (0) 1 41 91 8790

**National Semiconductor Asia
Pacific Customer Support Center**
Email: ap.support@nsc.com

**National Semiconductor Japan
Customer Support Center**
Fax: 81-3-5639-7507
Email: jpn.feedback@nsc.com
Tel: 81-3-5639-7560