

LM2771 Low-Ripple 250mA Switched Capacitor Step-Down DC/DC Converter

Check for Samples: [LM2771](#)

FEATURES

- Low-Noise Fixed Frequency Operation
- 1.5V Output Voltage
- Li-Ion (3.6V) to 1.5V with 81% Efficiency
- 1.7% Output Voltage Accuracy
- Very Low Output Ripple: 8mV @ 250mA
- Output Currents up to 250mA
- 2.7V to 5.5V Input Range
- Shutdown Disconnects Load from V_{IN}
- 1.1MHz Switching Frequency

- No Inductors...Small Solution Size
- Current Limit and Thermal Protection
- WSON-10 Package (3mm × 3mm × 0.8mm)

APPLICATIONS

- DSP, Memory, and Microprocessor Power Supplies
- Mobile Phones and Pagers
- Portable Electronic Devices

DESCRIPTION

The LM2771 is a switched capacitor step-down regulator that produces a 1.5V output without the use of an inductor. It is capable of supplying loads up to 250mA. The LM2771 operates with an input voltage from 2.7V to 5.5V, and requires only 3 low-cost ceramic capacitors.

The LM2771 uses a regulated 0.5x charge pump to give power conversion efficiencies nearly twice as high as an LDO. Pre-regulated 1.1MHz fixed-frequency switching results in very low ripple and noise on both the input and the output. When output currents are low (<30mA typ.), the part automatically switches to a low-ripple PFM regulation mode to maintain high efficiency over the entire load range. At input voltages below 3.5V (Typ), the charge pump goes into pass mode, with efficiencies similar to an LDO.

The LM2771 is available in National's 10-pad Leadless Leadframe No-Pullback Package (WSON-10).

Typical Application Circuit

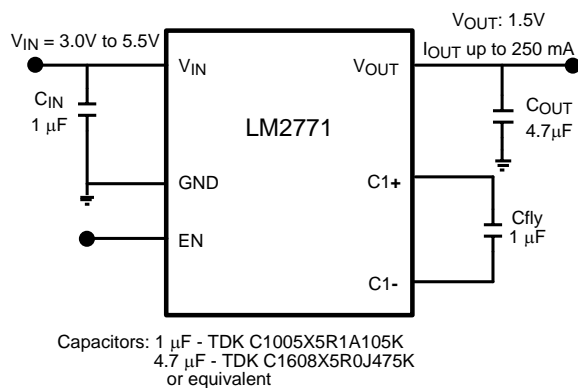

LM2771 Efficiency vs. Low-Dropout Linear Regulator (LDO) Efficiency

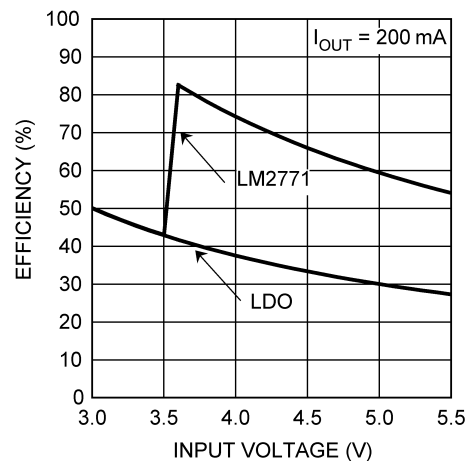

Please be aware that an important notice concerning availability, standard warranty, and use in critical applications of Texas Instruments semiconductor products and disclaimers thereto appears at the end of this data sheet.

All trademarks are the property of their respective owners.

Connection Diagram

**Figure 1. 10-Pin Non-Pullback Leadless Frame Package (WSON-10)
Package Number DSC0010A**

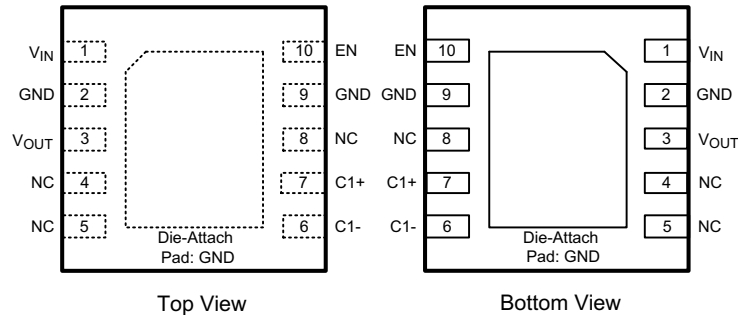

Pin Descriptions

Pin #	Name	Description
1	V _{IN}	Input Voltage: Recommended V _{IN} operating range 3.0V to 5.5V.
2	GND	Ground
3	V _{OUT}	Output Voltage
4	NC	No Connect
5	NC	No Connect
6	C1-	Flying Capacitor 1: Negative Terminal
7	C1+	Flying Capacitor 1: Positive Terminal
8	NC	No Connect
9	GND	Ground
10	EN	Enable Pin Logic Input. Applying a logic HIGH voltage signal enables the part. A logic LOW voltage signal places the the device in shutdown.



These devices have limited built-in ESD protection. The leads should be shorted together or the device placed in conductive foam during storage or handling to prevent electrostatic damage to the MOS gates.

Absolute Maximum Ratings⁽¹⁾⁽²⁾⁽³⁾

V _{IN} Pin Voltage		-0.3V to 6.0V
EN Pin Voltage		-0.3V to (V _{IN} +0.3V) w/ 6.0V max
Continuous Power Dissipation ⁽⁴⁾		Internally Limited
Junction Temperature (T _{J-MAX})		150°C
Storage Temperature Range		-65°C to +150° C
Maximum Lead Temperature ⁽⁵⁾		265°C
ESD Rating ⁽⁶⁾	Human Body Model	2.0kV
	Machine Model	200V

- (1) Absolute Maximum Ratings indicate limits beyond which damage to the component may occur. Operating Ratings are conditions under which operation of the device is guaranteed. Operating Ratings do not imply guaranteed performance limits. For guaranteed performance limits and associated test conditions, see the Electrical Characteristics tables.
- (2) If Military/Aerospace specified devices are required, please contact the Texas Instruments Sales Office/ Distributors for availability and specifications.
- (3) All voltages are with respect to the potential at the GND pins.
- (4) Internal thermal shutdown circuitry protects the device from permanent damage. Thermal shutdown engages at T_J=150°C (typ.) and disengages at T_J=140°C (typ.).
- (5) For detailed information on soldering requirements and recommendations, please refer to National Semiconductor's Application Note 1187 (AN-1187): Leadless Leadframe Package (LLP).
- (6) The Human body model is a 100pF capacitor discharged through a 1.5kΩ resistor into each pin. The machine model is a 200pF capacitor discharged directly into each pin. MIL-STD-883 3015.7

Operating Ratings⁽¹⁾⁽²⁾

Input Voltage Range	2.7V to 5.5V
Recommended Load Current Range	0mA to 250mA
Junction Temperature (T _J) Range	-30°C to +110°C
Ambient Temperature (T _A) Range ⁽³⁾	-30°C to +85°C

- (1) Absolute Maximum Ratings indicate limits beyond which damage to the component may occur. Operating Ratings are conditions under which operation of the device is guaranteed. Operating Ratings do not imply guaranteed performance limits. For guaranteed performance limits and associated test conditions, see the Electrical Characteristics tables.
- (2) All voltages are with respect to the potential at the GND pins.
- (3) Maximum ambient temperature (T_{A-MAX}) is dependent on the maximum operating junction temperature (T_{J-MAX-OP} = 110°C), the maximum power dissipation of the device in the application (P_{D-MAX}), and the junction-to ambient thermal resistance of the part/package in the application (θ_{JA}), as given by the following equation: T_{A-MAX} = T_{J-MAX-OP} – (θ_{JA} × P_{D-MAX}).

Thermal Properties

Junction-to-Ambient Thermal Resistance (θ _{JA}), WSON-10 Package ⁽¹⁾	55°C/W
---	--------

- (1) Junction-to-ambient thermal resistance is highly application and board-layout dependent. In applications where high maximum power dissipation exists, special care must be paid to thermal dissipation issues.

Electrical Characteristics⁽¹⁾⁽²⁾

Limits in standard typeface are for T_J = 25°C. Limits in **boldface** type apply over the full operating junction temperature range (-30°C ≤ T_J ≤ +110°C). Unless otherwise noted, specifications apply to the LM2771 Typical Application Circuit (pg. 1) with: V_{IN} = 3.6V; V(EN) = 1.8V, C_{IN} = C₁ = 1.0μF, C_{OUT} = 4.7μF.⁽³⁾

Symbol	Parameter	Condition	Min	Typ	Max	Units
V _{OUT}	1.5V Output Voltage Regulation	3.0V ≤ V _{IN} ≤ 5.5V 0mA ≤ I _{OUT} ≤ 200mA	1.455 (-3%)	1.5	1.545 (+3%)	V
		3.0V ≤ V _{IN} ≤ 5.5V I _{OUT} = 150mA	1.475 (-1.7%)	1.5	1.525 (+1.7%)	
		3.0V < V _{IN} ≤ 5.5V, 0mA ≤ I _{OUT} ≤ 250mA	1.445 (-3.7%)	1.5	1.545 (+3%)	
V _{OUT} /I _{OUT}	Output Load Regulation	V _{OUT} = 1.5V 0mA ≤ I _{OUT} ≤ 250mA		0.17		mV/mA
V _{OUT} /V _{IN}	Output Line Regulation			0.1		%/V
E	Power Efficiency	I _{OUT} = 200mA		81		%
I _Q	Quiescent Supply Current	I _{OUT} = 0mA ⁽⁴⁾		45	50	μA
V _R	Fixed Frequency Output Ripple	40mA ≤ I _{OUT} ≤ 250mA		8		mV
V _{R-PFM}	PFM-Mode Output Ripple	I _{OUT} < 40mA		12		mV
I _{SD}	Shutdown Current	V(EN) = 0V		0.1	0.5	μA
F _{SW}	Switching Frequency	3.2V ≤ V _{IN} ≤ 5.5V	0.80	1.1	1.40	MHz
R _{OL}	Open-Loop Output Resistance	I _{OUT} = 200mA ⁽⁵⁾		1.0		Ω
I _{CL}	Output Current Limit	V _{IN} = 5.5V 0V ≤ V _{OUT} ≤ 0.2V ⁽⁶⁾		500		mA
t _{ON}	Turn-on Time			150		μs
V _{IL}	Logic-low Input Voltage	3.0V ≤ V _{IN} ≤ 5.5V	0		0.5	V
V _{IH}	Logic-high Input Voltage	3.0V ≤ V _{IN} ≤ 5.5V	0.95		V _{IN}	V
I _{IH}	Logic-high Input Current	V(EN) = 1.8V ⁽⁷⁾		5		μA
I _{IL}	Logic-low Input Current	Logic Input = 0V		0.1		μA

- (1) All voltages are with respect to the potential at the GND pins.
- (2) Min and Max limits are guaranteed by design, test, or statistical analysis. Typical numbers are not guaranteed, but do represent the most likely norm.
- (3) C_{IN}, C_{OUT}, C₁: Low-ESR Surface-Mount Ceramic Capacitors (MLCCs) used in setting electrical characteristics.
- (4) V_{OUT} is set to 1.6V during this test.
- (5) Open loop output resistance can be used to predict output voltage when, under low V_{IN} and high I_{OUT} conditions, V_{OUT} falls out of regulation. V_{OUT} = V_{IN}/2 – (R_{OL} × I_{OUT})
- (6) Maximum input current is equal to half the maximum output current for buck-mode switched capacitor converters.
- (7) There is a 350kΩ pull-down resistor connected internally between the EN pin and GND.

Block Diagram

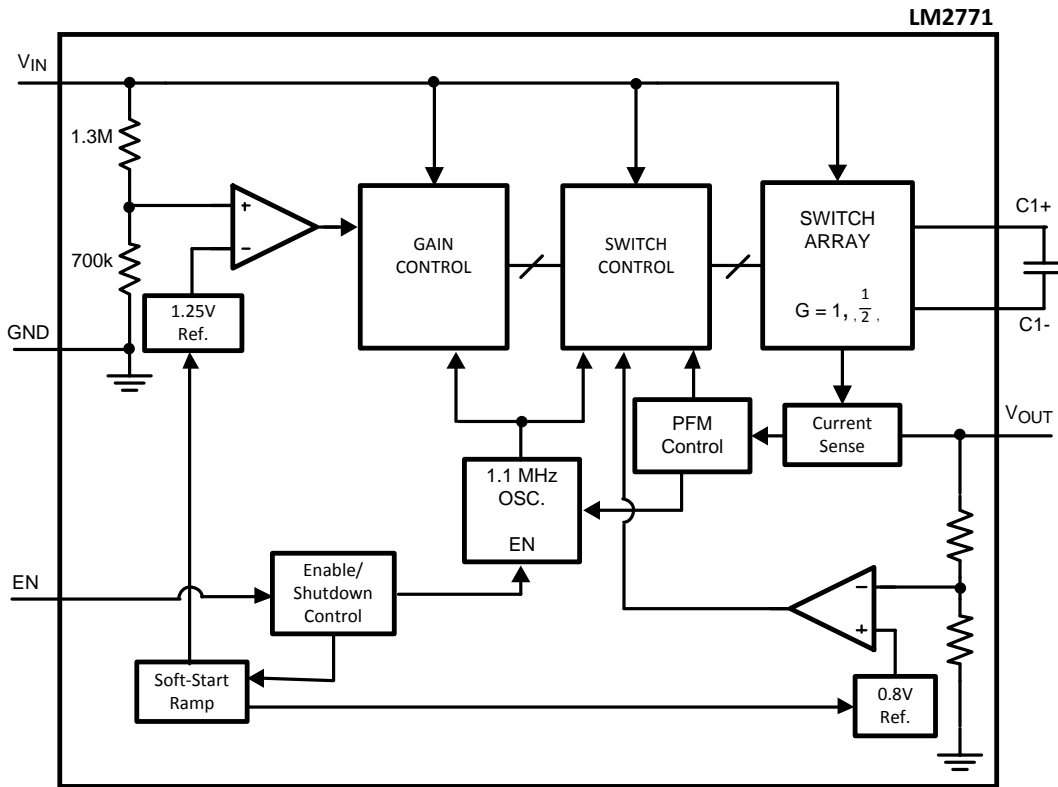

Typical Performance Characteristics

Unless otherwise specified: $V_{IN} = 3.6V$, $C_{IN} = C_1 = 1.0\mu F$, $C_{OUT} = 4.7\mu F$, $T_A = 25^\circ C$. Capacitors are low-ESR multi-layer ceramic capacitors (MLCC's).

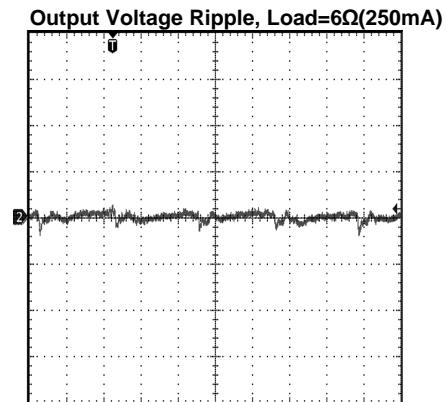
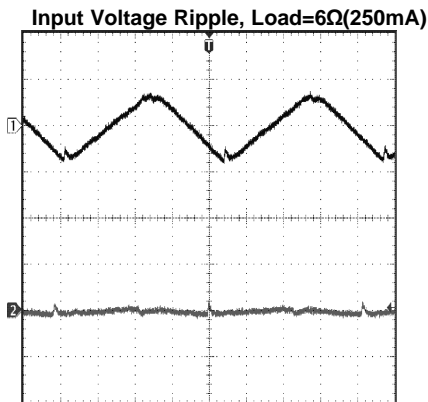
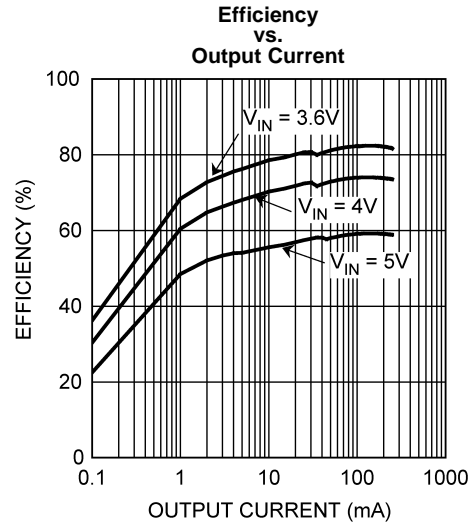
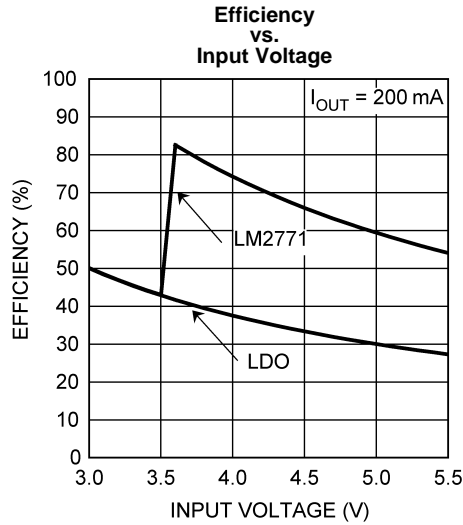
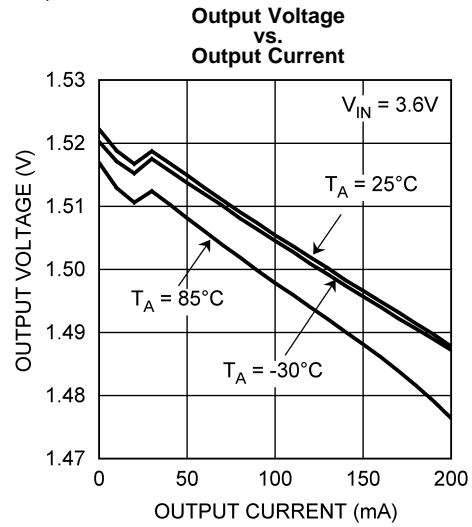
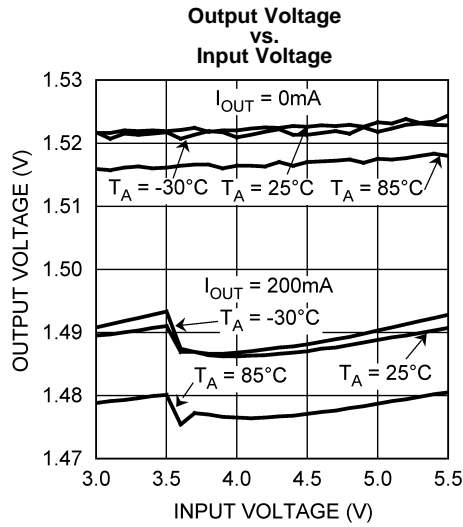

CH1: V_{IN} , $C_{IN} = 1\mu F$; Scale: 50mV/Div, AC Coupled
 CH2: V_{IN} , $C_{IN} = 10\mu F$; Scale: 50mV/Div, AC Coupled
 Time scale: 200ns/Div

CH2: V_{OUT} , $C_{OUT} = 4.7\mu F$; Scale: 20mV/Div, AC Coupled
 Time scale: 200ns/Div

Typical Performance Characteristics (continued)

Unless otherwise specified: $V_{IN} = 3.6V$, $C_{IN} = C_1 = 1.0\mu F$, $C_{OUT} = 4.7\mu F$, $T_A = 25^\circ C$. Capacitors are low-ESR multi-layer ceramic capacitors (MLCC's).

Load Step, 15mA to 200mA

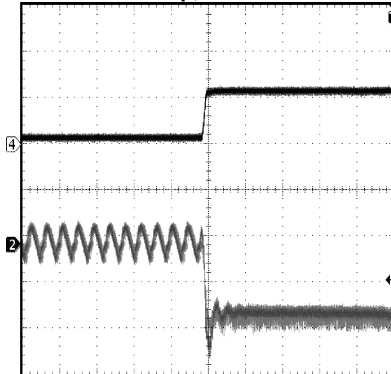

CH2: V_{OUT} ; Scale: 20mV/Div, AC Coupled
 CH4: I_{OUT} ; Scale: 200mA/Div
 Time scale: 20 μ s/Div

Load Step, 200mA to 15mA

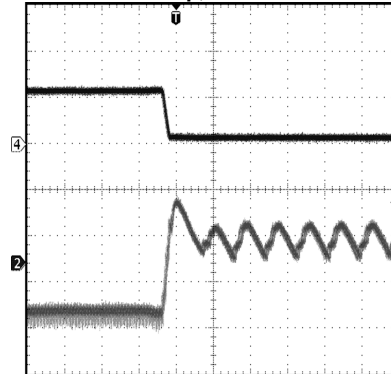

CH2: V_{OUT} ; Scale: 20mV/Div, AC Coupled
 CH4: I_{OUT} ; Scale: 200mA/Div
 Time scale: 10 μ s/Div

Line Step, 3.6V to 4.5V with Load=7.5 Ω (200mA)

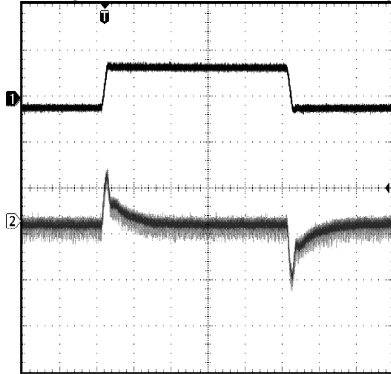

CH1: V_{IN} ; Scale: 1V/Div, AC Coupled
 CH2: V_{OUT} ; Scale: 20mV/Div, AC Coupled
 Time scale: 40 μ s/Div

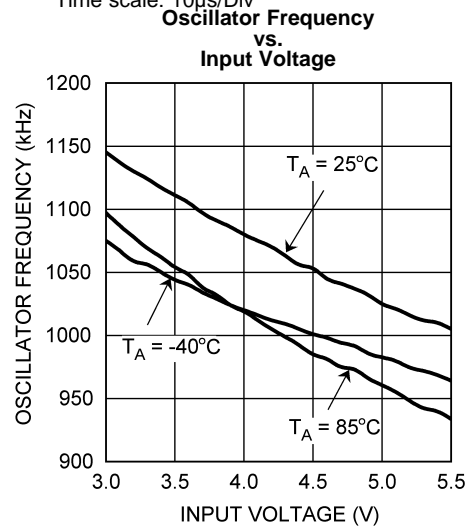

Startup and Shutdown Behavior, Load=6 Ω (250mA)

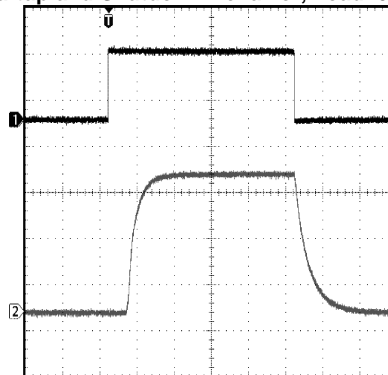

CH1: V_{EN} ; Scale: 2V/Div, DC Coupled
 CH2: V_{OUT} ; Scale: 500mV/Div, DC Coupled
 Time scale: 100 μ s/Div

OPERATION DESCRIPTION

OVERVIEW

The LM2771 is a switched capacitor converter that produces a regulated, low voltage output. The core of the part is a highly efficient charge pump that utilizes fixed frequency pre-regulation and Pulse Frequency Modulation to minimize ripple and power losses over wide input voltage and output current ranges. A description of the principal operational characteristics of the LM2771 is detailed in the [CIRCUIT DESCRIPTION](#), and [EFFICIENCY PERFORMANCE](#) sections. These sections refer to details in the [Block Diagram](#).

CIRCUIT DESCRIPTION

The core of the LM2771 is a two-phase charge pump controlled by an internally generated non-overlapping clock. The charge pump operates by using an external flying capacitor, C1, to transfer charge from the input to the output. At input voltages below 3.5V (typ.) the LM2771 operates in a "pass mode", with the input current being equal to the load current. At input voltages above 3.5V (typ.) the part utilizes a gain of ½, resulting in an input current equal to half the load current.

The two phases of the switched capacitor switching cycle will be referred to as the "charge phase" and the "discharge phase". During the charge phase, the flying capacitor is charged by the input supply. After half of the switching cycle [$t = 1/(2 \times F_{SW})$], the LM2771 switches to the discharge phase. In this configuration, the charge that was stored on the flying capacitor in the charge phase is transferred to the output.

The LM2771 uses fixed frequency pre-regulation to regulate the output voltage to 1.5V during moderate to high load currents. The input and output connections of the flying capacitor is made with internal MOS switches. Pre-regulation limits the gate drive of the MOS switch connected between the voltage input and the flying capacitor. Controlling the on resistance of this switch limits the amount of charge transferred into and out of the flying capacitor during the charge and discharge phases, and in turn helps to keep the output ripple very low.

When output currents are low (<30mA typ.), the LM2771 automatically switches to a low-ripple Pulse Frequency Modulation (PFM) form of regulation. In PFM mode, the flying capacitor stays in the discharge phase until the output voltage drops below a predetermined trip point. When this occurs, the flying capacitor switches back to the charge phase. After being charged, the flying capacitor repeats the process of staying in the discharge phase and switching to the charge phase when necessary.

EFFICIENCY PERFORMANCE

Charge-pump efficiency is derived in the following two ideal equations (supply current and other losses are neglected for simplicity):

$$I_{IN} = G \times I_{OUT} \quad E = (V_{OUT} \times I_{OUT}) \div (V_{IN} \times I_{IN}) = V_{OUT} \div (G \times V_{IN}) \quad (1)$$

In the equations, G represents the charge pump gain. Efficiency is at its highest as $G \times V_{IN}$ approaches V_{OUT} . Refer to the efficiency graph in the [Typical Performance Characteristics](#) section for detailed efficiency data. The transition between Pass mode and the gain of ½ is clearly distinguished by the sharp discontinuity in the efficiency curve.

SHUTDOWN

The LM2771 is in shutdown mode when the voltage on the enable pin (EN) is logic-low. In shutdown, the LM2771 draws virtually no supply current. When in shutdown, the output of the LM2771 is completely disconnected from the input. The internal feedback resistors will pull the output voltage down to 0V.

SOFT START

The LM2771 employs soft start circuitry to prevent excessive input inrush currents during startup. At startup, the output voltage gradually rises from 0V to the nominal output voltage. This occurs in 150µs (typ.). Soft-start is engaged when the part is enabled, including situations where voltage is established simultaneously on the V_{IN} and EN pins.

THERMAL SHUTDOWN

Protection from damage related to overheating is achieved with a thermal shutdown feature. When the junction temperature rises to 150°C (typ.), the part switches into shutdown mode. The LM2771 disengages thermal shutdown when the junction temperature of the part is reduced to 140°C (typ.). Due to the high efficiency of the LM2771, thermal shutdown and/or thermal cycling should not be encountered when the part is operated within specified input voltage, output current, and ambient temperature operating ratings. If thermal cycling is seen under these conditions, the most likely cause is an inadequate PCB layout that does not allow heat to be sufficiently dissipated out of the WSON package.

CURRENT LIMIT PROTECTION

The LM2771 charge pump contains current limit protection circuitry that protects the device during V_{OUT} fault conditions where excessive current is drawn. Output current is limited to 500mA (typ).

Application Information

RECOMMENDED CAPACITOR TYPES

The LM2771 requires 3 external capacitors for proper operation. Surface-mount multi-layer ceramic capacitors are recommended. These capacitors are small, inexpensive and have very low equivalent series resistance (ESR, $\leq 15\text{m}\Omega$ typ.). Tantalum capacitors, OS-CON capacitors, and aluminum electrolytic capacitors generally are not recommended for use with the LM2771 due to their high ESR, as compared to ceramic capacitors.

For most applications, ceramic capacitors with an X7R or X5R temperature characteristic are preferred for use with the LM2771. These capacitors have tight capacitance tolerance (as good as $\pm 10\%$) and hold their value over temperature (X7R: $\pm 15\%$ over -55°C to 125°C ; X5R: $\pm 15\%$ over -55°C to 85°C).

Capacitors with a Y5V or Z5U temperature characteristic are generally not recommended for use with the LM2771. These types of capacitors typically have wide capacitance tolerance ($+80\%$, -20%) and vary significantly over temperature (Y5V: $+22\%$, -82% over -30°C to $+85^\circ\text{C}$ range; Z5U: $+22\%$, -56% over $+10^\circ\text{C}$ to $+85^\circ\text{C}$ range). Under some conditions, a $1\mu\text{F}$ -rated Y5V or Z5U capacitor could have a capacitance as low as $0.1\mu\text{F}$. Such detrimental deviation is likely to cause Y5V and Z5U capacitors to fail to meet the minimum capacitance requirements of the LM2771.

Net capacitance of a ceramic capacitor decreases with increased DC bias. This degradation can result in lower capacitance than expected on the input and/or output, resulting in higher ripple voltages and currents. Using capacitors at DC bias voltages significantly below the capacitor voltage rating will usually minimize DC bias effects. Consult capacitor manufacturers for information on capacitor DC bias characteristics.

Capacitance characteristics can vary quite dramatically with different application conditions, capacitor types, and capacitor manufacturers. It is strongly recommended that the LM2771 circuit be thoroughly evaluated early in the design-in process with the mass-production capacitors of choice. This will help ensure that any such variability in capacitance does not negatively impact circuit performance.

The table below lists some leading ceramic capacitor manufacturers.

Manufacturer	Contact Information
AVX	www.avx.com
Murata	www.murata.com
Taiyo-Yuden	www.t-yuden.com
TDK	www.component.tdk.com
Vishay-Vitramon	www.vishay.com

OUTPUT CAPACITOR AND OUTPUT VOLTAGE RIPPLE

The output capacitor in the LM2771 circuit (C_{OUT}) directly impacts the magnitude of output voltage ripple. Other prominent factors also affecting output voltage ripple include input voltage, output current and flying capacitance. Due to the complexity of the regulation topology, providing equations or models to approximate the magnitude of the ripple can not be easily accomplished. But one important generalization can be made: increasing (decreasing) the output capacitance will result in a proportional decrease (increase) in output voltage ripple.

In typical high-current applications, a 4.7 μ F low-ESR ceramic output capacitor is recommended. Different output capacitance values can be used to reduce ripple, shrink the solution size, and/or cut the cost of the solution. But changing the output capacitor may also require changing the flying capacitor and/or input capacitor to maintain good overall circuit performance. Performance of the LM2771 with different capacitor setups is discussed in the section [RECOMMENDED CAPACITOR CONFIGURATIONS](#).

High ESR in the output capacitor increases output voltage ripple. If a ceramic capacitor is used at the output, this is usually not a concern because the ESR of a ceramic capacitor is typically very low and has only a minimal impact on ripple magnitudes. If a different capacitor type with higher ESR is used (tantalum, for example), the ESR could result in high ripple. To eliminate this effect, the net output ESR can be significantly reduced by placing a low-ESR ceramic capacitor in parallel with the primary output capacitor. The low ESR of the ceramic capacitor will be in parallel with the higher ESR, resulting in a low net ESR based on the principles of parallel resistance reduction.

INPUT CAPACITOR AND INPUT VOLTAGE RIPPLE

The input capacitor (C_{IN}) is a reservoir of charge that aids a quick transfer of charge from the supply to the flying capacitor during the charge phase of operation. The input capacitor helps to keep the input voltage from drooping at the start of the charge phase when the flying capacitor is connected to the input. It also filters noise on the input pin, keeping this noise out of sensitive internal analog circuitry that is biased off the input line.

Much like the relationship between the output capacitance and output voltage ripple, input capacitance has a dominant and first-order effect on input ripple magnitude. Increasing (decreasing) the input capacitance will result in a proportional decrease (increase) in input voltage ripple. Input voltage, output current, and flying capacitance also will affect input ripple levels to some degree.

In typical high-current applications, a 1 μ F low-ESR ceramic capacitor is recommended on the input. Different input capacitance values can be used to reduce ripple, shrink the solution size, and/or cut the cost of the solution. But changing the input capacitor may also require changing the flying capacitor and/or output capacitor to maintain good overall circuit performance. Performance of the LM2771 with different capacitor setups is discussed below in [RECOMMENDED CAPACITOR CONFIGURATIONS](#).

FLYING CAPACITOR

The flying capacitor (C_f) transfers charge from the input to the output. Flying capacitance can impact both output current capability and ripple magnitudes. If flying capacitance is too small, the LM2771 may not be able to regulate the output voltage when load currents are high. On the other hand, if the flying capacitance is too large, the flying capacitor might overwhelm the input and output capacitors, resulting in increased input and output ripple.

Polarized capacitors (tantalum, aluminum electrolytic, etc.) must not be used for the flying capacitor, as they could become reverse-biased during LM2771 operation.

RECOMMENDED CAPACITOR CONFIGURATIONS

The data in [Table 1](#) can be used to assist in the selection of a capacitor configuration that best balances solution size and cost with the electrical requirements of the application.

As previously discussed, input and output ripple voltages will vary with output current and input voltage. The numbers provided show expected ripple voltage when $V_{IN} = 3.6V$ and load currents are between 10mA and 200mA. The table offers first look at approximate ripple levels and provides a comparison for the different capacitor configurations presented, but is not intended to be a guarantee of performance.

Table 1. LM2771 Performance with Different Capacitor Configurations ⁽¹⁾

CAPACITOR CONFIGURATION ($V_{IN} = 3.6V$)	TYPICAL INPUT RIPPLE	TYPICAL OUTPUT RIPPLE
$C_{IN} = 1\mu F$, $C_{OUT} = 4.7\mu F$, $C_1 = 1\mu F$	45mV	8mV
$C_{IN} = 1\mu F$, $C_{OUT} = 2.2\mu F$, $C_1 = 1\mu F$	94mV	19mV
$C_{IN} = 0.47\mu F$, $C_{OUT} = 4.7\mu F$, $C_1 = 1\mu F$	105mV	11mV
$C_{IN} = 0.47\mu F$, $C_{OUT} = 3.3\mu F$, $C_1 = 1\mu F$	102mV	16mV
$C_{IN} = 0.47\mu F$, $C_{OUT} = 3.3\mu F$, $C_1 = 0.33\mu F$	120mV	15mV

(1) Refer to the text in the Recommended Capacitor Configurations section for detailed information on the data in this table

Layout Guidelines

Proper board layout will help to ensure optimal performance of the LM2771 circuit. The following guidelines are recommended:

- Place capacitors as close to the LM2771 as possible, and preferably on the same side of the board as the IC.
- Use short, wide traces to connect the external capacitors to the LM2771 to minimize trace resistance and inductance.
- Use a low resistance connection between ground and the GND pin of the LM2771. Using wide traces and/or multiple vias to connect GND to a ground plane on the board is most advantageous.

PACKAGING INFORMATION

Orderable Device	Status (1)	Package Type	Package Drawing	Pins	Package Qty	Eco Plan (2)	Lead/Ball Finish	MSL Peak Temp (3)	Op Temp (°C)	Top-Side Markings (4)	Samples
LM2771SD	ACTIVE	WSON	DSC	10	1000	TBD	Call TI	Call TI	-30 to 110	L2771	Samples
LM2771SD/NOPB	ACTIVE	WSON	DSC	10	1000	Green (RoHS & no Sb/Br)	CU SN	Level-1-260C-UNLIM	-30 to 110	L2771	Samples
LM2771SDX	ACTIVE	WSON	DSC	10	4500	TBD	Call TI	Call TI	-30 to 110	L2771	Samples
LM2771SDX/NOPB	ACTIVE	WSON	DSC	10	4500	Green (RoHS & no Sb/Br)	CU SN	Level-1-260C-UNLIM	-30 to 110	L2771	Samples

(1) The marketing status values are defined as follows:

ACTIVE: Product device recommended for new designs.

LIFEBUY: TI has announced that the device will be discontinued, and a lifetime-buy period is in effect.

NRND: Not recommended for new designs. Device is in production to support existing customers, but TI does not recommend using this part in a new design.

PREVIEW: Device has been announced but is not in production. Samples may or may not be available.

OBSOLETE: TI has discontinued the production of the device.

(2) Eco Plan - The planned eco-friendly classification: Pb-Free (RoHS), Pb-Free (RoHS Exempt), or Green (RoHS & no Sb/Br) - please check <http://www.ti.com/productcontent> for the latest availability information and additional product content details.

TBD: The Pb-Free/Green conversion plan has not been defined.

Pb-Free (RoHS): TI's terms "Lead-Free" or "Pb-Free" mean semiconductor products that are compatible with the current RoHS requirements for all 6 substances, including the requirement that lead not exceed 0.1% by weight in homogeneous materials. Where designed to be soldered at high temperatures, TI Pb-Free products are suitable for use in specified lead-free processes.

Pb-Free (RoHS Exempt): This component has a RoHS exemption for either 1) lead-based flip-chip solder bumps used between the die and package, or 2) lead-based die adhesive used between the die and leadframe. The component is otherwise considered Pb-Free (RoHS compatible) as defined above.

Green (RoHS & no Sb/Br): TI defines "Green" to mean Pb-Free (RoHS compatible), and free of Bromine (Br) and Antimony (Sb) based flame retardants (Br or Sb do not exceed 0.1% by weight in homogeneous material)

(3) MSL, Peak Temp. -- The Moisture Sensitivity Level rating according to the JEDEC industry standard classifications, and peak solder temperature.

(4) Only one of markings shown within the brackets will appear on the physical device.

Important Information and Disclaimer: The information provided on this page represents TI's knowledge and belief as of the date that it is provided. TI bases its knowledge and belief on information provided by third parties, and makes no representation or warranty as to the accuracy of such information. Efforts are underway to better integrate information from third parties. TI has taken and continues to take reasonable steps to provide representative and accurate information but may not have conducted destructive testing or chemical analysis on incoming materials and chemicals. TI and TI suppliers consider certain information to be proprietary, and thus CAS numbers and other limited information may not be available for release.

In no event shall TI's liability arising out of such information exceed the total purchase price of the TI part(s) at issue in this document sold by TI to Customer on an annual basis.

TAPE AND REEL INFORMATION

QUADRANT ASSIGNMENTS FOR PIN 1 ORIENTATION IN TAPE

*All dimensions are nominal

Device	Package Type	Package Drawing	Pins	SPQ	Reel Diameter (mm)	Reel Width W1 (mm)	A0 (mm)	B0 (mm)	K0 (mm)	P1 (mm)	W (mm)	Pin1 Quadrant
LM2771SD	WSON	DSC	10	1000	178.0	12.4	3.3	3.3	1.0	8.0	12.0	Q1
LM2771SD/NOPB	WSON	DSC	10	1000	178.0	12.4	3.3	3.3	1.0	8.0	12.0	Q1
LM2771SDX	WSON	DSC	10	4500	330.0	12.4	3.3	3.3	1.0	8.0	12.0	Q1
LM2771SDX/NOPB	WSON	DSC	10	4500	330.0	12.4	3.3	3.3	1.0	8.0	12.0	Q1

TAPE AND REEL BOX DIMENSIONS

*All dimensions are nominal

Device	Package Type	Package Drawing	Pins	SPQ	Length (mm)	Width (mm)	Height (mm)
LM2771SD	WSON	DSC	10	1000	203.0	190.0	41.0
LM2771SD/NOPB	WSON	DSC	10	1000	203.0	190.0	41.0
LM2771SDX	WSON	DSC	10	4500	349.0	337.0	45.0
LM2771SDX/NOPB	WSON	DSC	10	4500	349.0	337.0	45.0

DSC0010A

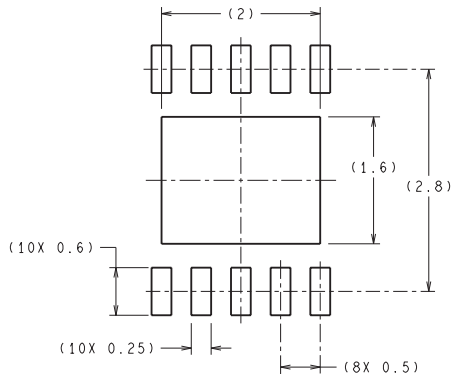

RECOMMENDED LAND PATTERN

DIMENSIONS ARE IN MILLIMETERS
DIMENSIONS IN () FOR REFERENCE ONLY

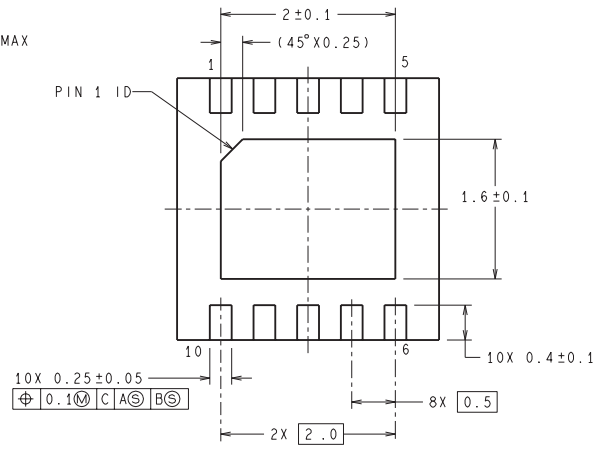
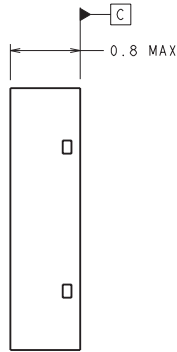
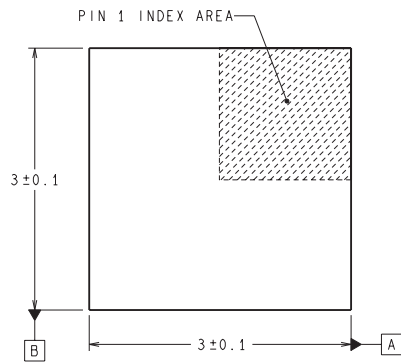
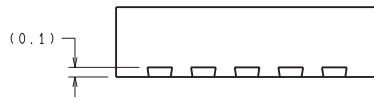

SDA10A (Rev A)

IMPORTANT NOTICE

Texas Instruments Incorporated and its subsidiaries (TI) reserve the right to make corrections, enhancements, improvements and other changes to its semiconductor products and services per JESD46, latest issue, and to discontinue any product or service per JESD48, latest issue. Buyers should obtain the latest relevant information before placing orders and should verify that such information is current and complete. All semiconductor products (also referred to herein as "components") are sold subject to TI's terms and conditions of sale supplied at the time of order acknowledgment.

TI warrants performance of its components to the specifications applicable at the time of sale, in accordance with the warranty in TI's terms and conditions of sale of semiconductor products. Testing and other quality control techniques are used to the extent TI deems necessary to support this warranty. Except where mandated by applicable law, testing of all parameters of each component is not necessarily performed.

TI assumes no liability for applications assistance or the design of Buyers' products. Buyers are responsible for their products and applications using TI components. To minimize the risks associated with Buyers' products and applications, Buyers should provide adequate design and operating safeguards.

TI does not warrant or represent that any license, either express or implied, is granted under any patent right, copyright, mask work right, or other intellectual property right relating to any combination, machine, or process in which TI components or services are used. Information published by TI regarding third-party products or services does not constitute a license to use such products or services or a warranty or endorsement thereof. Use of such information may require a license from a third party under the patents or other intellectual property of the third party, or a license from TI under the patents or other intellectual property of TI.

Reproduction of significant portions of TI information in TI data books or data sheets is permissible only if reproduction is without alteration and is accompanied by all associated warranties, conditions, limitations, and notices. TI is not responsible or liable for such altered documentation. Information of third parties may be subject to additional restrictions.

Resale of TI components or services with statements different from or beyond the parameters stated by TI for that component or service voids all express and any implied warranties for the associated TI component or service and is an unfair and deceptive business practice. TI is not responsible or liable for any such statements.

Buyer acknowledges and agrees that it is solely responsible for compliance with all legal, regulatory and safety-related requirements concerning its products, and any use of TI components in its applications, notwithstanding any applications-related information or support that may be provided by TI. Buyer represents and agrees that it has all the necessary expertise to create and implement safeguards which anticipate dangerous consequences of failures, monitor failures and their consequences, lessen the likelihood of failures that might cause harm and take appropriate remedial actions. Buyer will fully indemnify TI and its representatives against any damages arising out of the use of any TI components in safety-critical applications.

In some cases, TI components may be promoted specifically to facilitate safety-related applications. With such components, TI's goal is to help enable customers to design and create their own end-product solutions that meet applicable functional safety standards and requirements. Nonetheless, such components are subject to these terms.

No TI components are authorized for use in FDA Class III (or similar life-critical medical equipment) unless authorized officers of the parties have executed a special agreement specifically governing such use.

Only those TI components which TI has specifically designated as military grade or "enhanced plastic" are designed and intended for use in military/aerospace applications or environments. Buyer acknowledges and agrees that any military or aerospace use of TI components which have **not** been so designated is solely at the Buyer's risk, and that Buyer is solely responsible for compliance with all legal and regulatory requirements in connection with such use.

TI has specifically designated certain components as meeting ISO/TS16949 requirements, mainly for automotive use. In any case of use of non-designated products, TI will not be responsible for any failure to meet ISO/TS16949.

Products

Audio	www.ti.com/audio
Amplifiers	amplifier.ti.com
Data Converters	dataconverter.ti.com
DLP® Products	www.dlp.com
DSP	dsp.ti.com
Clocks and Timers	www.ti.com/clocks
Interface	interface.ti.com
Logic	logic.ti.com
Power Mgmt	power.ti.com
Microcontrollers	microcontroller.ti.com
RFID	www.ti-rfid.com
OMAP Applications Processors	www.ti.com/omap
Wireless Connectivity	www.ti.com/wirelessconnectivity

Applications

Automotive and Transportation	www.ti.com/automotive
Communications and Telecom	www.ti.com/communications
Computers and Peripherals	www.ti.com/computers
Consumer Electronics	www.ti.com/consumer-apps
Energy and Lighting	www.ti.com/energy
Industrial	www.ti.com/industrial
Medical	www.ti.com/medical
Security	www.ti.com/security
Space, Avionics and Defense	www.ti.com/space-avionics-defense
Video and Imaging	www.ti.com/video

TI E2E Community

e2e.ti.com

Mouser Electronics

Authorized Distributor

Click to View Pricing, Inventory, Delivery & Lifecycle Information:

[Texas Instruments:](#)

[LM2771SD](#) [LM2771SDX](#)