

LM25576

SIMPLE SWITCHER® 42V, 3A Step-Down Switching Regulator

General Description

The LM25576 is an easy to use SIMPLE SWITCHER® buck regulator which allows design engineers to design and optimize a robust power supply using a minimum set of components. Operating with an input voltage range of 6 - 42V, the LM25576 delivers 3A of continuous output current with an integrated 170mΩ N-Channel MOSFET. The regulator utilizes an Emulated Current Mode architecture which provides inherent line regulation, tight load transient response, and ease of loop compensation without the usual limitation of low-duty cycles associated with current mode regulators. The operating frequency is adjustable from 50kHz to 1MHz to allow optimization of size and efficiency. To reduce EMI, a frequency synchronization pin allows multiple IC's from the LM(2)557x family to self-synchronize or to synchronize to an external clock. The LM25576 guarantees robustness with cycle-by-cycle current limit, short-circuit protection, thermal shut-down, and remote shut-down. The device is available in a power enhanced TSSOP-20 package featuring an exposed die attach pad for thermal dissipation. The LM25576 is supported by the full suite of WEBENCH® On-Line design tools.

Features

- Integrated 42V, 170mΩ N-channel MOSFET
- Ultra-wide input voltage range from 6V to 42V
- Adjustable output voltage as low as 1.225V
- 1.5% feedback reference accuracy
- Operating frequency adjustable between 50kHz and 1MHz with single resistor
- Master or slave frequency synchronization
- Adjustable soft-start
- Emulated current mode control architecture
- Wide bandwidth error amplifier
- Built-in protection

Package

- TSSOP-20EP (Exposed Pad)

Simplified Application Schematic

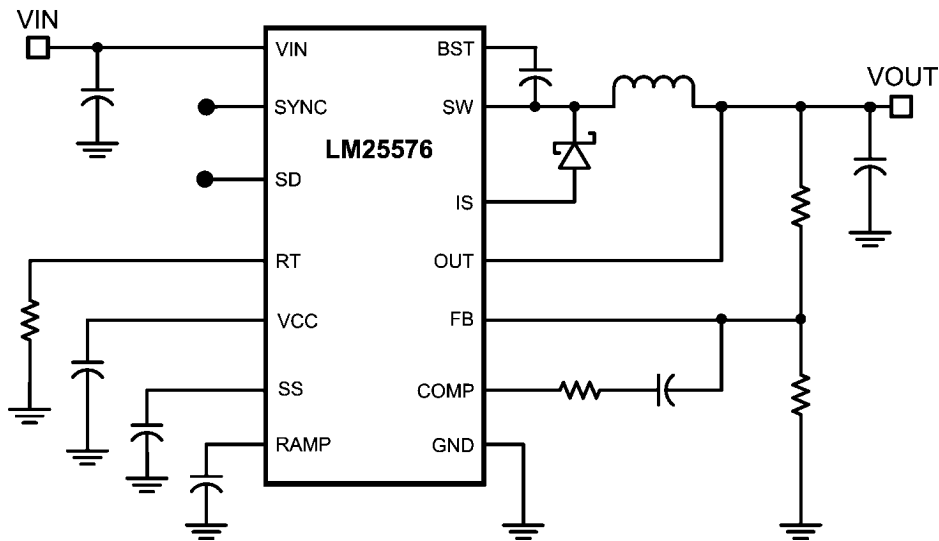

20208701

Connection Diagram

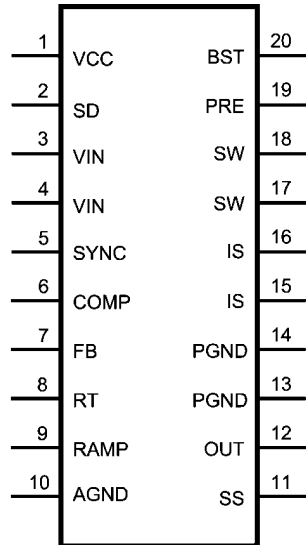

20208702

Top View
20-Lead TSSOP

Ordering Information

Order Number	Package Type	NSC Package Drawing	Supplied As
LM25576MH	Exposed Pad TSSOP-20	MXA20A	73 Units in Rail
LM25576MHX	Exposed Pad TSSOP-20	MXA20A	2500 Units on Tape and Reel

Pin Descriptions

Pin(s)	Name	Description	Application Information
1	VCC	Output of the bias regulator	Vcc tracks Vin up to 9V. Beyond 9V, Vcc is regulated to 7 Volts. A 0.1uF to 1uF ceramic decoupling capacitor is required. An external voltage (7.5V – 14V) can be applied to this pin to reduce internal power dissipation.
2	SD	Shutdown or UVLO input	If the SD pin voltage is below 0.7V the regulator will be in a low power state. If the SD pin voltage is between 0.7V and 1.225V the regulator will be in standby mode. If the SD pin voltage is above 1.225V the regulator will be operational. An external voltage divider can be used to set a line undervoltage shutdown threshold. If the SD pin is left open circuit, a 5μA pull-up current source configures the regulator fully operational.
3, 4	Vin	Input supply voltage	Nominal operating range: 6V to 42V
5	SYNC	Oscillator synchronization input or output	The internal oscillator can be synchronized to an external clock with an external pull-down device. Multiple LM25576 devices can be synchronized together by connection of their SYNC pins.
6	COMP	Output of the internal error amplifier	The loop compensation network should be connected between this pin and the FB pin.
7	FB	Feedback signal from the regulated output	This pin is connected to the inverting input of the internal error amplifier. The regulation threshold is 1.225V.
8	RT	Internal oscillator frequency set input	The internal oscillator is set with a single resistor, connected between this pin and the AGND pin.
9	RAMP	Ramp control signal	An external capacitor connected between this pin and the AGND pin sets the ramp slope used for current mode control. Recommended capacitor range 50pF to 2000pF.
10	AGND	Analog ground	Internal reference for the regulator control functions
11	SS	Soft-start	An external capacitor and an internal 10μA current source set the time constant for the rise of the error amp reference. The SS pin is held low during standby, Vcc UVLO and thermal shutdown.
12	OUT	Output voltage connection	Connect directly to the regulated output voltage.
13, 14	PGND	Power ground	Low side reference for the PRE switch and the IS sense resistor.
15, 16	IS	Current sense	Current measurement connection for the re-circulating diode. An internal sense resistor and a sample/hold circuit sense the diode current near the conclusion of the off-time. This current measurement provides the DC level of the emulated current ramp.
17, 18	SW	Switching node	The source terminal of the internal buck switch. The SW pin should be connected to the external Schottky diode and to the buck inductor.
19	PRE	Pre-charge assist for the bootstrap capacitor	This open drain output can be connected to SW pin to aid charging the bootstrap capacitor during very light load conditions or in applications where the output may be pre-charged before the LM25576 is enabled. An internal pre-charge MOSFET is turned on for 265ns each cycle just prior to the on-time interval of the buck switch.

Pin(s)	Name	Description	Application Information
20	BST	Boost input for bootstrap capacitor	An external capacitor is required between the BST and the SW pins. A 0.022 μ F ceramic capacitor is recommended. The capacitor is charged from Vcc via an internal diode during the off-time of the buck switch.
NA	EP	Exposed Pad	Exposed metal pad on the underside of the device. It is recommended to connect this pad to the PWB ground plane, in order to aid in heat dissipation.

Absolute Maximum Ratings (Note 1)

If Military/Aerospace specified devices are required, please contact the National Semiconductor Sales Office/Distributors for availability and specifications.

V_{IN} to GND	45V
BST to GND	60V
PRE to GND	45V
SW to GND (Steady State)	-1.5V
BST to V_{CC}	45V
SD, V_{CC} to GND	14V

BST to SW	14V
OUT to GND	Limited to V_{IN}
SYNC, SS, FB, RAMP to GND	7V
ESD Rating (Note 2)	
Human Body Model	2kV
Storage Temperature Range	-65°C to +150°C

Operating Ratings (Note 1)

V_{IN}	6V to 42V
Operation Junction Temperature	-40°C to +125°C

Electrical Characteristics Specifications with standard typeface are for $T_J = 25^\circ\text{C}$, and those with **boldface** type apply over full **Operating Junction Temperature range**. $V_{IN} = 24\text{V}$, $R_T = 32.4\text{k}\Omega$ unless otherwise stated. (Note 3)

Symbol	Parameter	Conditions	Min	Typ	Max	Units
STARTUP REGULATOR						
VccReg	Vcc Regulator Output		6.85	7.15	7.45	V
	Vcc LDO Mode turn-off			9		V
	Vcc Current Limit	$V_{CC} = 0\text{V}$		25		mA
VCC SUPPLY						
	Vcc UVLO Threshold	(Vcc increasing)	5.03	5.35	5.67	V
	Vcc Undervoltage Hysteresis			0.25		V
	Bias Current (lin)	FB = 1.3V		3.4	4.5	mA
	Shutdown Current (lin)	SD = 0V		48	70	μA
SHUTDOWN THRESHOLDS						
	Shutdown Threshold	(SD Increasing)	0.47	0.7	0.9	V
	Shutdown Hysteresis			0.1		V
	Standby Threshold	(Standby Increasing)	1.17	1.225	1.28	V
	Standby Hysteresis			0.1		V
	SD Pull-up Current Source			5		μA
SWITCH CHARACTERISTICS						
	Buck Switch Rds(on)			170	340	m Ω
	BOOST UVLO			3.8		V
	BOOST UVLO Hysteresis			0.56		V
	Pre-charge Switch Rds(on)			70		Ω
	Pre-charge Switch on-time			265		ns
CURRENT LIMIT						
	Cycle by Cycle Current Limit	RAMP = 0V	3.6	4.2	5.1	A
	Cycle by Cycle Current Limit Delay	RAMP = 2.5V		100		ns
SOFT-START						
	SS Current Source		7	10	14	μA
OSCILLATOR						
	Frequency1		180	200	220	kHz
	Frequency2	$R_T = 11\text{k}\Omega$	425	485	545	kHz
	SYNC Source Impedance			11		k Ω
	SYNC Sink Impedance			110		Ω
	SYNC Threshold (falling)			1.3		V
	SYNC Frequency	$R_T = 11\text{k}\Omega$	550			kHz
	SYNC Pulse Width Minimum		15			ns

Symbol	Parameter	Conditions	Min	Typ	Max	Units
RAMP GENERATOR						
	Ramp Current 1	Vin = 36V, Vout=10V	136	160	184	μA
	Ramp Current 2	Vin = 10V, Vout=10V	18	25	32	μA
PWM COMPARATOR						
	Forced Off-time		416	500	575	ns
	Min On-time			80		ns
	COMP to PWM Comparator Offset			0.7		V
ERROR AMPLIFIER						
	Feedback Voltage	Vfb = COMP	1.207	1.225	1.243	V
	FB Bias Current			17		nA
	DC Gain			70		dB
	COMP Sink / Source Current		3			mA
	Unity Gain Bandwidth			3		MHz
DIODE SENSE RESISTANCE						
D _{SENSE}				42		mΩ
THERMAL SHUTDOWN						
Tsd	Thermal Shutdown Threshold			165		°C
	Thermal Shutdown Hysteresis			25		°C
THERMAL RESISTANCE						
θ _{JC}	Junction to Case			6		°C/W
θ _{JA}	Junction to Ambient			40		°C/W

Note 1: Absolute Maximum Ratings are limits beyond which damage to the device may occur. Operating Ratings are conditions under which operation of the device is intended to be functional. For guaranteed specifications and test conditions, see the Electrical Characteristics.

Note 2: The human body model is a 100pF capacitor discharged through a 1.5kΩ resistor into each pin.

Note 3: Min and Max limits are 100% production tested at 25°C. Limits over the operating temperature range are guaranteed through correlation using Statistical Quality Control (SQC) methods. Limits are used to calculate National's Average Outgoing Quality Level (AOQL).

Typical Performance Characteristics

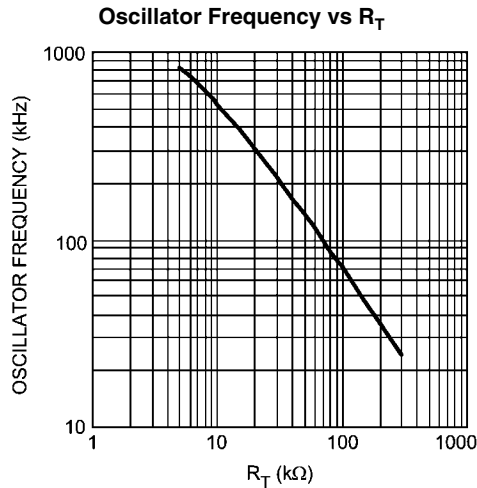

20208720

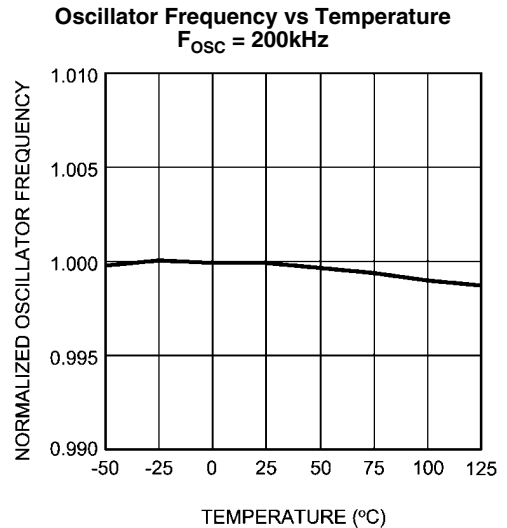

20208721

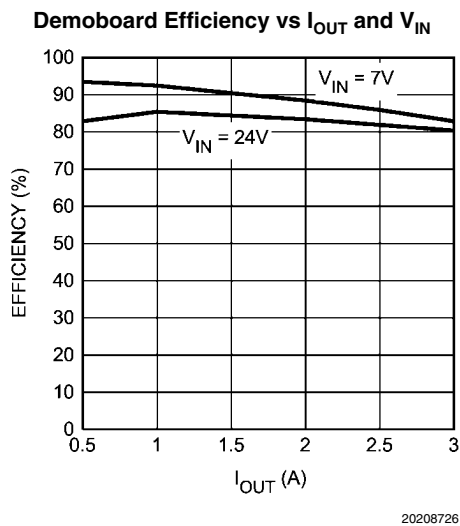
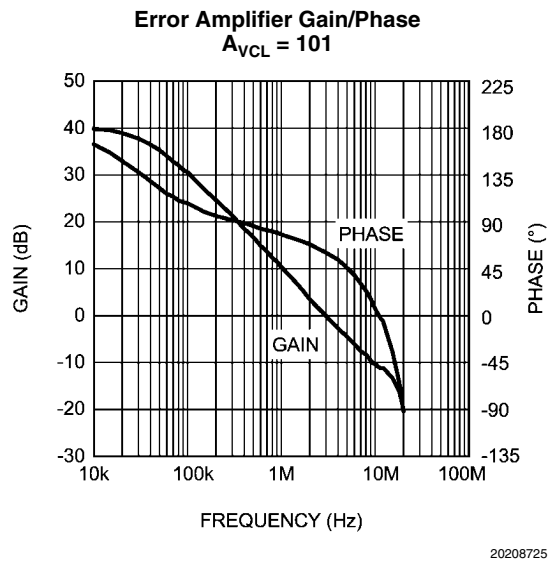
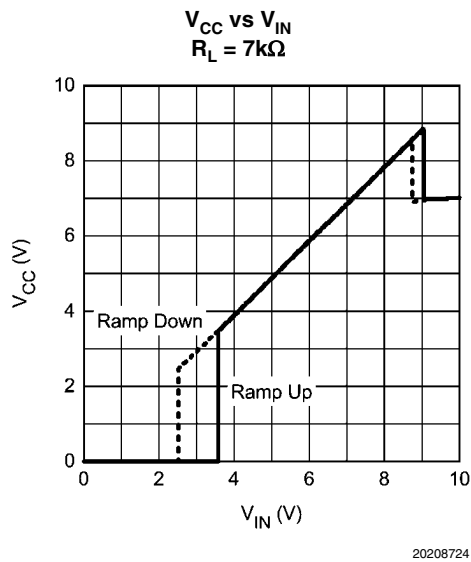
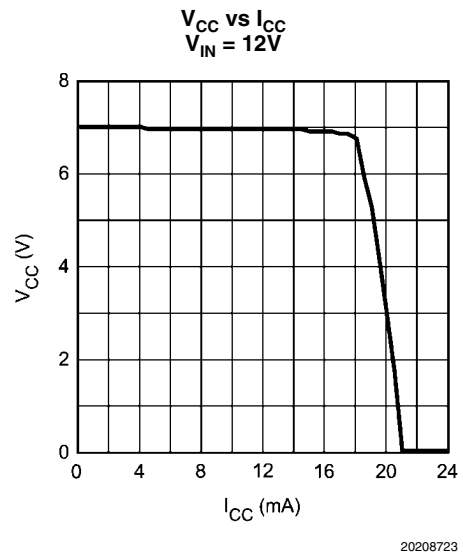
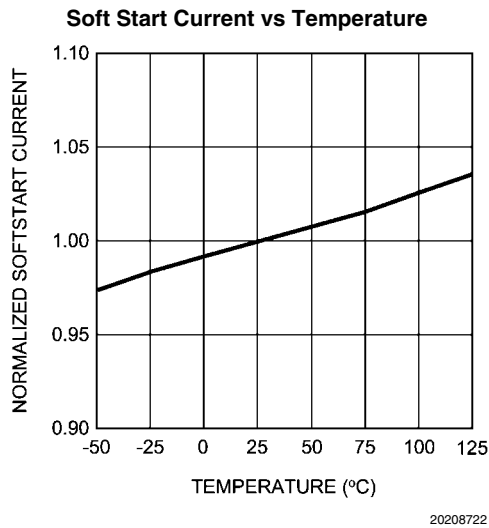

Typical Application Circuit and Block Diagram

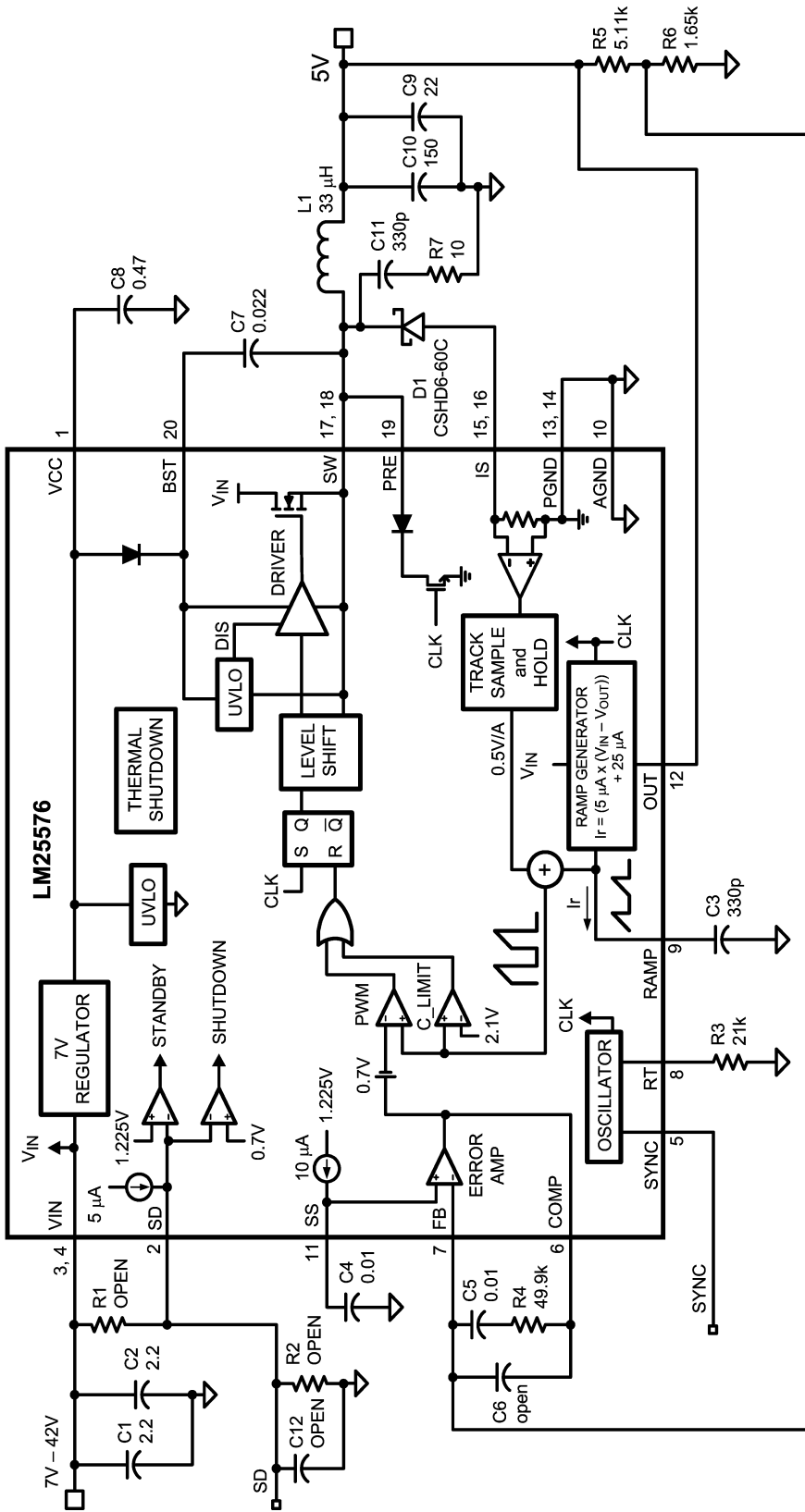

20206703

FIGURE 1.

Detailed Operating Description

The LM25576 switching regulator features all of the functions necessary to implement an efficient high voltage buck regulator using a minimum of external components. This easy to use regulator integrates a 42V N-Channel buck switch with an output current capability of 3 Amps. The regulator control method is based on current mode control utilizing an emulated current ramp. Peak current mode control provides inherent line voltage feed-forward, cycle-by-cycle current limiting, and ease of loop compensation. The use of an emulated control ramp reduces noise sensitivity of the pulse-width modulation circuit, allowing reliable processing of very small duty cycles necessary in high input voltage applications. The operating frequency is user programmable from 50kHz to 1MHz. An oscillator synchronization pin allows multiple LM25576 regulators to self synchronize or be synchronized to an external clock. The output voltage can be set as low as 1.225V. Fault protection features include, current limiting, thermal shutdown and remote shutdown capability. The device is available in the TSSOP-20 package featuring an exposed pad to aid thermal dissipation.

The functional block diagram and typical application of the LM25576 are shown in *Figure 1*. The LM25576 can be applied in numerous applications to efficiently step-down a high, unregulated input voltage. The device is well suited for telecom, industrial and automotive power bus voltage ranges.

High Voltage Start-Up Regulator

The LM25576 contains a dual-mode internal high voltage startup regulator that provides the V_{CC} bias supply for the

PWM controller and boot-strap MOSFET gate driver. The input pin (V_{IN}) can be connected directly to the input voltage, as high as 42 Volts. For input voltages below 9V, a low dropout switch connects V_{CC} directly to V_{IN} . In this supply range, V_{CC} is approximately equal to V_{IN} . For V_{IN} voltage greater than 9V, the low dropout switch is disabled and the V_{CC} regulator is enabled to maintain V_{CC} at approximately 7V. The wide operating range of 6V to 42V is achieved through the use of this dual mode regulator.

The output of the V_{CC} regulator is current limited to 25mA. Upon power up, the regulator sources current into the capacitor connected to the V_{CC} pin. When the voltage at the V_{CC} pin exceeds the V_{CC} UVLO threshold of 5.35V and the SD pin is greater than 1.225V, the output switch is enabled and a soft-start sequence begins. The output switch remains enabled until V_{CC} falls below 5.0V or the SD pin falls below 1.125V.

An auxiliary supply voltage can be applied to the V_{CC} pin to reduce the IC power dissipation. If the auxiliary voltage is greater than 7.3V, the internal regulator will essentially shut off, reducing the IC power dissipation. The V_{CC} regulator series pass transistor includes a diode between V_{CC} and V_{IN} that should not be forward biased in normal operation. Therefore the auxiliary V_{CC} voltage should never exceed the V_{IN} voltage.

In high voltage applications extra care should be taken to ensure the V_{IN} pin does not exceed the absolute maximum voltage rating of 45V. During line or load transients, voltage ringing on the V_{IN} line that exceeds the Absolute Maximum Ratings can damage the IC. Both careful PC board layout and the use of quality bypass capacitors located close to the V_{IN} and GND pins are essential.

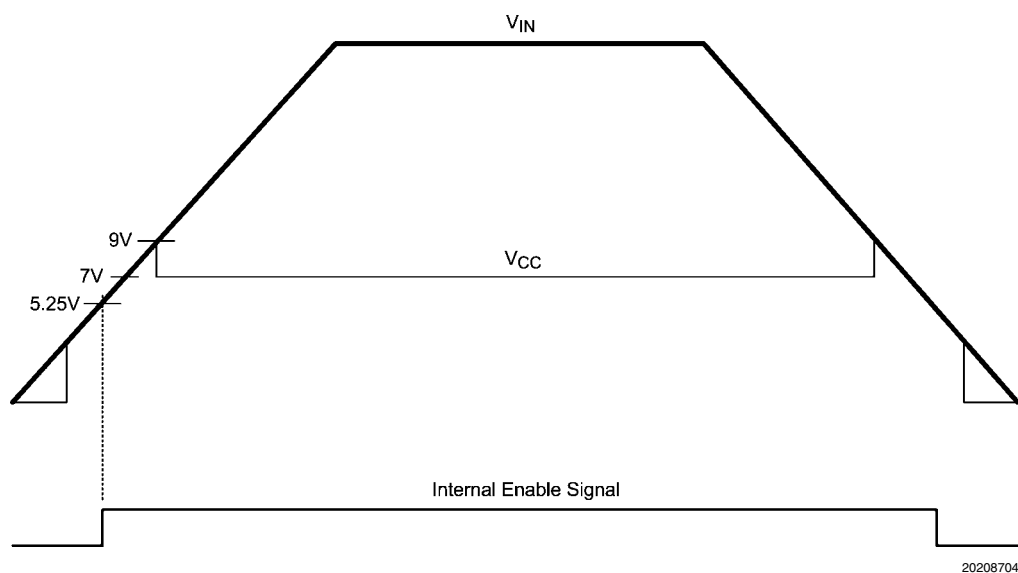

FIGURE 2. V_{in} and V_{cc} Sequencing

Shutdown / Standby

The LM25576 contains a dual level Shutdown (SD) circuit. When the SD pin voltage is below 0.7V, the regulator is in a low current shutdown mode. When the SD pin voltage is greater than 0.7V but less than 1.225V, the regulator is in standby mode. In standby mode the V_{CC} regulator is active but the output switch is disabled. When the SD pin voltage exceeds 1.225V, the output switch is enabled and normal operation begins. An internal 5μA pull-up current source configures the regulator to be fully operational if the SD pin is left open.

An external set-point voltage divider from VIN to GND can be used to set the operational input range of the regulator. The divider must be designed such that the voltage at the SD pin will be greater than 1.225V when Vin is in the desired operating range. The internal 5μA pull-up current source must be included in calculations of the external set-point divider. Hysteresis of 0.1V is included for both the shutdown and standby thresholds. The SD pin is internally clamped with a 1kΩ resistor and an 8V zener clamp. The voltage at the SD pin should never exceed 14V. If the voltage at the SD pin exceeds 8V, the bias current will increase at a rate of 1 mA/V.

The SD pin can also be used to implement various remote enable / disable functions. Pulling the SD pin below the 0.7V threshold totally disables the controller. If the SD pin voltage is above 1.225V the regulator will be operational.

Oscillator and Sync Capability

The LM25576 oscillator frequency is set by a single external resistor connected between the RT pin and the AGND pin. The R_T resistor should be located very close to the device and connected directly to the pins of the IC (RT and AGND). To set a desired oscillator frequency (F), the necessary value for the R_T resistor can be calculated from the following equation:

$$R_T = \frac{\frac{1}{F} - 580 \times 10^{-9}}{135 \times 10^{-12}}$$

The SYNC pin can be used to synchronize the internal oscillator to an external clock. The external clock must be of **higher frequency** than the free-running frequency set by the R_T resistor. A clock circuit with an open drain output is the recommended interface from the external clock to the SYNC pin. The clock pulse duration should be greater than 15ns.

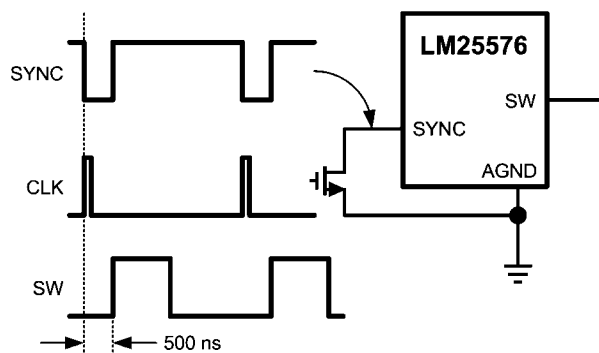
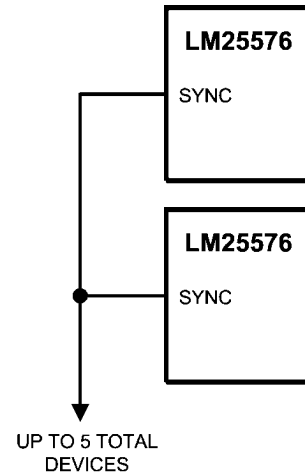

FIGURE 3. Sync from External Clock



20208706

FIGURE 4. Sync from Multiple Devices

Multiple LM25576 devices can be synchronized together simply by connecting the SYNC pins together. In this configuration all of the devices will be synchronized to the highest frequency device. The diagram in *Figure 5* illustrates the SYNC input/output features of the LM25576. The internal oscillator circuit drives the SYNC pin with a strong pull-down / weak pull-up inverter. When the SYNC pin is pulled low either by the internal oscillator or an external clock, the ramp cycle of the oscillator is terminated and a new oscillator cycle begins. Thus, if the SYNC pins of several LM25576 IC's are connected together, the IC with the highest internal clock frequency will pull the connected SYNC pins low first and terminate the oscillator ramp cycles of the other IC's. The LM25576 with the highest programmed clock frequency will serve as the master and control the switching frequency of the all the devices with lower oscillator frequency.

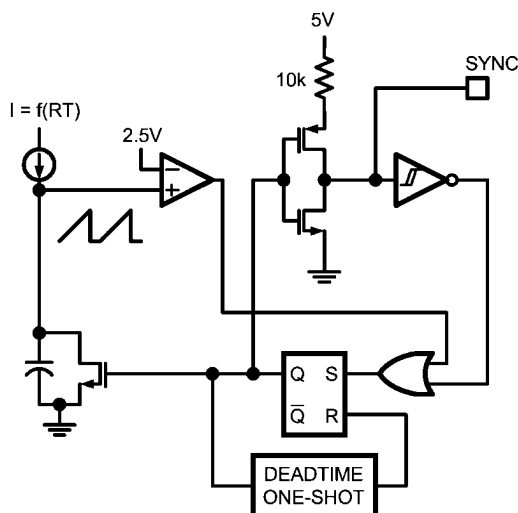

20208707

FIGURE 5. Simplified Oscillator Block Diagram and SYNC I/O Circuit

Error Amplifier and PWM Comparator

The internal high gain error amplifier generates an error signal proportional to the difference between the regulated output voltage and an internal precision reference (1.225V). The output of the error amplifier is connected to the COMP pin allowing the user to provide loop compensation components, generally a type II network, as illustrated in *Figure 1*. This network creates a pole at DC, a zero and a noise reducing high frequency pole. The PWM comparator compares the emulated current sense signal from the RAMP generator to the error amplifier output voltage at the COMP pin.

RAMP Generator

The ramp signal used in the pulse width modulator for current mode control is typically derived directly from the buck switch current. This switch current corresponds to the positive slope portion of the output inductor current. Using this signal for the PWM ramp simplifies the control loop transfer function to a single pole response and provides inherent input voltage feed-forward compensation. The disadvantage of using the buck switch current signal for PWM control is the large leading edge spike due to circuit parasitics that must be filtered or blanked. Also, the current measurement may introduce significant propagation delays. The filtering, blanking time and propagation delay limit the minimum achievable pulsewidth. In applications where the input voltage may be relatively large in comparison to the output voltage, controlling small pulsewidths and duty cycles is necessary for regulation. The LM25576 utilizes a unique ramp generator, which does not actually measure the buck switch current but rather reconstructs the signal. Reconstructing or emulating the inductor current provides a ramp signal to the PWM comparator that is free of leading edge spikes and measurement or filtering delays. The current reconstruction is comprised of two elements; a sample & hold DC level and an emulated current ramp.

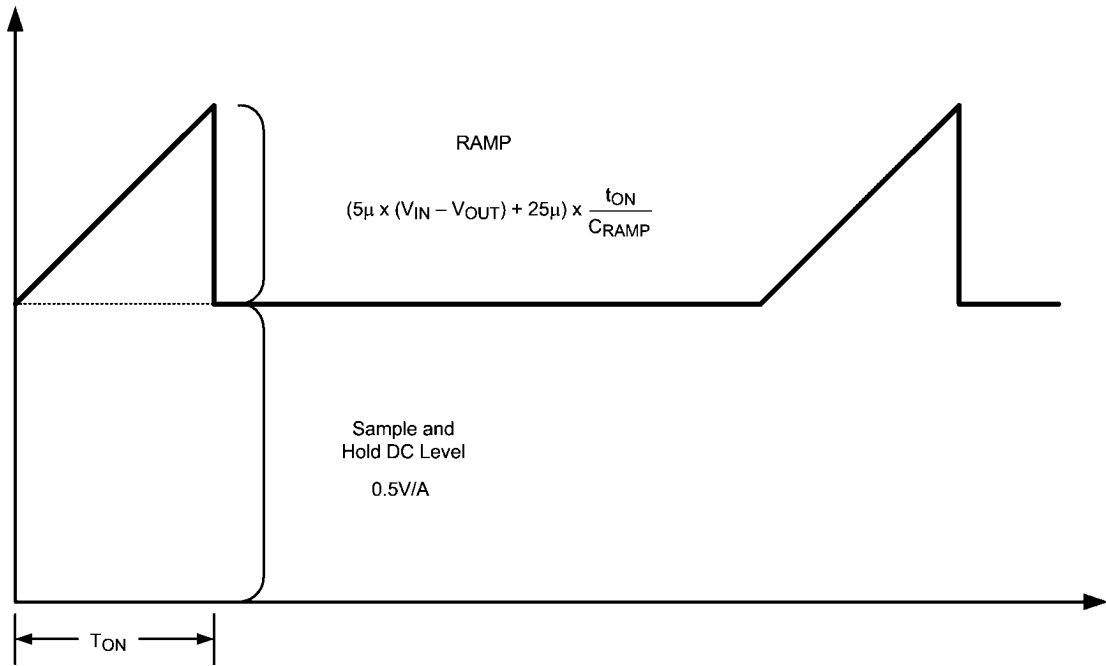

20208708

FIGURE 6. Composition of Current Sense Signal

The sample & hold DC level illustrated in *Figure 6* is derived from a measurement of the re-circulating Schottky diode anode current. The re-circulating diode anode should be connected to the IS pin. The diode current flows through an internal current sense resistor between the IS and PGND pins. The voltage level across the sense resistor is sampled and held just prior to the onset of the next conduction interval of the buck switch. The diode current sensing and sample & hold provide the DC level of the reconstructed current signal. The positive slope inductor current ramp is emulated by an external capacitor connected from the RAMP pin to AGND and an internal voltage controlled current source. The ramp current source that emulates the inductor current is a function of the V_{in} and V_{out} voltages per the following equation:

$$I_{RAMP} = (5\mu \times (V_{in} - V_{out})) + 25\mu A$$

Proper selection of the RAMP capacitor depends upon the selected value of the output inductor. The value of C_{RAMP} can be selected from: $C_{RAMP} = L \times 10^{-5}$, where L is the value of the output inductor in Henrys. With this value, the scale factor of the emulated current ramp will be approximately equal to the scale factor of the DC level sample and hold (0.5 V / A). The C_{RAMP} capacitor should be located very close to the device and connected directly to the pins of the IC (RAMP and AGND).

For duty cycles greater than 50%, peak current mode control circuits are subject to sub-harmonic oscillation. Sub-harmonic

oscillation is normally characterized by observing alternating wide and narrow pulses at the switch node. Adding a fixed slope voltage ramp (slope compensation) to the current sense signal prevents this oscillation. The 25μA of offset current provided from the emulated current source adds some fixed slope to the ramp signal. In some high output voltage, high duty cycle applications, additional slope may be required. In these applications, a pull-up resistor may be added between the V_{CC} and RAMP pins to increase the ramp slope compensation.

For $V_{OUT} > 7.5V$:

Calculate optimal slope current, $I_{OS} = V_{OUT} \times 5\mu A/V$.

For example, at $V_{OUT} = 10V$, $I_{OS} = 50\mu A$.

Install a resistor from the RAMP pin to V_{CC} :

$$R_{RAMP} = V_{CC} / (I_{OS} - 25\mu A)$$

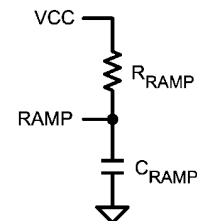

20208745

FIGURE 7. R_{RAMP} to V_{CC} for $V_{OUT} > 7.5V$

Maximum Duty Cycle / Input Dropout Voltage

There is a forced off-time of 500ns implemented each cycle to guarantee sufficient time for the diode current to be sampled. This forced off-time limits the maximum duty cycle of the buck switch. The maximum duty cycle will vary with the operating frequency.

$$D_{MAX} = 1 - F_s \times 500ns$$

Where F_s is the oscillator frequency. Limiting the maximum duty cycle will raise the input dropout voltage. The input dropout voltage is the lowest input voltage required to maintain regulation of the output voltage. An approximation of the input dropout voltage is:

$$V_{in_{MIN}} = \frac{V_{out} + V_D}{1 - F_s \times 500 ns}$$

Where V_D is the voltage drop across the re-circulatory diode. Operating at high switching frequency raises the minimum input voltage necessary to maintain regulation.

Current Limit

The LM25576 contains a unique current monitoring scheme for control and over-current protection. When set correctly, the emulated current sense signal provides a signal which is proportional to the buck switch current with a scale factor of 0.5 V / A. The emulated ramp signal is applied to the current limit comparator. If the emulated ramp signal exceeds 2.1V (4.2A) the present current cycle is terminated (cycle-by-cycle current limiting). In applications with small output inductance and high input voltage the switch current may overshoot due to the propagation delay of the current limit comparator. If an overshoot should occur, the diode current sampling circuit will detect the excess inductor current during the off-time of the buck switch. If the sample & hold DC level exceeds the 2.1V current limit threshold, the buck switch will be disabled and skip pulses until the diode current sampling circuit detects the inductor current has decayed below the current limit threshold. This approach prevents current runaway conditions due to propagation delays or inductor saturation since the inductor current is forced to decay following any current overshoot.

Soft-Start

The soft-start feature allows the regulator to gradually reach the initial steady state operating point, thus reducing start-up

stresses and surges. The internal soft-start current source, set to 10 μ A, gradually increases the voltage of an external soft-start capacitor connected to the SS pin. The soft-start capacitor voltage is connected to the reference input of the error amplifier. Various sequencing and tracking schemes can be implemented using external circuits that limit or clamp the voltage level of the SS pin.

In the event a fault is detected (over-temperature, V_{cc} UVLO, SD) the soft-start capacitor will be discharged. When the fault condition is no longer present a new soft-start sequence will commence.

Boost Pin

The LM25576 integrates an N-Channel buck switch and associated floating high voltage level shift / gate driver. This gate driver circuit works in conjunction with an internal diode and an external bootstrap capacitor. A 0.022 μ F ceramic capacitor, connected with short traces between the BST pin and SW pin, is recommended. During the off-time of the buck switch, the SW pin voltage is approximately -0.5V and the bootstrap capacitor is charged from V_{cc} through the internal bootstrap diode. When operating with a high PWM duty cycle, the buck switch will be forced off each cycle for 500ns to ensure that the bootstrap capacitor is recharged.

Under very light load conditions or when the output voltage is pre-charged, the SW voltage will not remain low during the off-time of the buck switch. If the inductor current falls to zero and the SW pin rises, the bootstrap capacitor will not receive sufficient voltage to operate the buck switch gate driver. For these applications, the PRE pin can be connected to the SW pin to pre-charge the bootstrap capacitor. The internal pre-charge MOSFET and diode connected between the PRE pin and PGND turns on each cycle for 265ns just prior to the onset of a new switching cycle. If the SW pin is at a normal negative voltage level (continuous conduction mode), then no current will flow through the pre-charge MOSFET/diode.

Thermal Protection

Internal Thermal Shutdown circuitry is provided to protect the integrated circuit in the event the maximum junction temperature is exceeded. When activated, typically at 165 $^{\circ}$ C, the controller is forced into a low power reset state, disabling the output driver and the bias regulator. This feature is provided to prevent catastrophic failures from accidental device over-heating.

Application Information

EXTERNAL COMPONENTS

The procedure for calculating the external components is illustrated with the following design example. The Bill of Materials for this design is listed in *Table 1*. The circuit shown in *Figure 1* is configured for the following specifications:

- $V_{OUT} = 5V$
- $V_{IN} = 7V$ to $42V$
- $F_s = 300kHz$
- Minimum load current (for CCM) = $250mA$
- Maximum load current = $3A$

R3 (R_T)

R_T sets the oscillator switching frequency. Generally, higher frequency applications are smaller but have higher losses. Operation at $300kHz$ was selected for this example as a reasonable compromise for both small size and high efficiency. The value of R_T for $300kHz$ switching frequency can be calculated as follows:

$$R_T = \frac{[(1 / 300 \times 10^3) - 580 \times 10^{-9}]}{135 \times 10^{-12}}$$

The nearest standard value of $21k\Omega$ was chosen for R_T .

L1

The inductor value is determined based on the operating frequency, load current, ripple current, and the minimum and maximum input voltage ($V_{IN(min)}$, $V_{IN(max)}$).

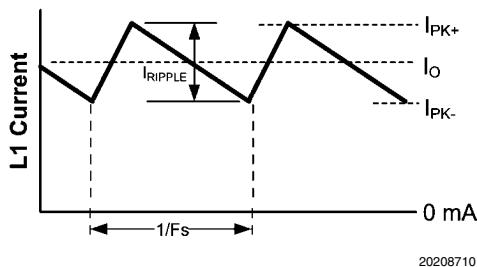

FIGURE 8. Inductor Current Waveform

To keep the circuit in continuous conduction mode (CCM), the maximum ripple current I_{RIPPLE} should be less than twice the minimum load current, or $0.5A_{p-p}$. Using this value of ripple current, the value of inductor ($L1$) is calculated using the following:

$$L1 = \frac{V_{OUT} \times (V_{IN(max)} - V_{OUT})}{I_{RIPPLE} \times F_s \times V_{IN(max)}}$$

$$L1 = \frac{5V \times (42V - 5V)}{0.5A \times 300 \text{ kHz} \times 42V} = 29 \mu H$$

This procedure provides a guide to select the value of $L1$. The nearest standard value ($33\mu H$) will be used. $L1$ must be rated for the peak current (I_{PK+}) to prevent saturation. During normal loading conditions, the peak current occurs at maximum load current plus maximum ripple. During an overload condition the peak current is limited to $4.2A$ nominal ($5.1A$ maximum).

The selected inductor (see *Table 1*) has a conservative $6.2A$ saturation current rating. For this manufacturer, the saturation rating is defined as the current necessary for the inductance to reduce by 30% , at $20^\circ C$.

C3 (C_{RAMP})

With the inductor value selected, the value of $C3$ (C_{RAMP}) necessary for the emulation ramp circuit is:

$$C_{RAMP} = L \times 10^{-5}$$

Where L is in Henrys

With $L1$ selected for $33\mu H$ the recommended value for $C3$ is $330pF$.

C9, C10

The output capacitors, $C9$ and $C10$, smooth the inductor ripple current and provide a source of charge for transient loading conditions. For this design a $22\mu F$ ceramic capacitor and a $150\mu F$ SP organic capacitor were selected. The ceramic capacitor provides ultra low ESR to reduce the output ripple voltage and noise spikes, while the SP capacitor provides a large bulk capacitance in a small volume for transient loading conditions. An approximation for the output ripple voltage is:

$$\Delta V_{OUT} = \Delta I_L \times \left(ESR + \frac{1}{8 \times F_s \times C_{OUT}} \right)$$

D1

A Schottky type re-circulating diode is required for all LM25576 applications. Ultra-fast diodes are not recommended and may result in damage to the IC due to reverse recovery current transients. The near ideal reverse recovery characteristics and low forward voltage drop are particularly important diode characteristics for high input voltage and low output voltage applications common to the LM25576. The reverse recovery characteristic determines how long the current surge lasts each cycle when the buck switch is turned on. The reverse recovery characteristics of Schottky diodes minimize the peak instantaneous power in the buck switch occurring during turn-on each cycle. The resulting switching losses of the buck switch are significantly reduced when using a Schottky diode. The reverse breakdown rating should be selected for the maximum V_{IN} , plus some safety margin.

The forward voltage drop has a significant impact on the conversion efficiency, especially for applications with a low output voltage. "Rated" current for diodes vary widely from various manufacturers. The worst case is to assume a short circuit load condition. In this case the diode will carry the output current almost continuously. For the LM25576 this current can be as high as $4.2A$. Assuming a worst case $1V$ drop across the diode, the maximum diode power dissipation can be as high as $4.2W$. For the reference design a $60V$ Schottky in a DPAK package was selected.

C1, C2

The regulator supply voltage has a large source impedance at the switching frequency. Good quality input capacitors are necessary to limit the ripple voltage at the V_{IN} pin while supplying most of the switch current during the on-time. When the buck switch turns on, the current into the V_{IN} pin steps to the lower peak of the inductor current waveform, ramps up to the peak value, then drops to zero at turn-off. The average current into V_{IN} during the on-time is the load current. The input ca-

capacitance should be selected for RMS current rating and minimum ripple voltage. A good approximation of the required ripple current rating necessary is $I_{RMS} > I_{OUT} / 2$.

Quality ceramic capacitors with a low ESR should be selected for the input filter. To allow for capacitor tolerances and voltage effects, two 2.2 μ F, 100V ceramic capacitors will be used. If step input voltage transients are expected near the maximum rating of the LM25576, a careful evaluation of ringing and possible spikes at the device VIN pin should be completed. An additional damping network or input voltage clamp may be required in these cases.

C8

The capacitor at the VCC pin provides noise filtering and stability for the V_{CC} regulator. The recommended value of C8 should be no smaller than 0.1 μ F, and should be a good quality, low ESR, ceramic capacitor. A value of 0.47 μ F was selected for this design.

C7

The bootstrap capacitor between the BST and the SW pins supplies the gate current to charge the buck switch gate at turn-on. The recommended value of C7 is 0.022 μ F, and should be a good quality, low ESR, ceramic capacitor.

C4

The capacitor at the SS pin determines the soft-start time, i.e. the time for the reference voltage and the output voltage, to reach the final regulated value. The time is determined from:

$$t_{ss} = \frac{C4 \times 1.225V}{10 \mu A}$$

For this application, a C4 value of 0.01 μ F was chosen which corresponds to a soft-start time of 1ms.

R5, R6

R5 and R6 set the output voltage level, the ratio of these resistors is calculated from:

$$R5/R6 = (V_{OUT} / 1.225V) - 1$$

For a 5V output, the R5/R6 ratio calculates to 3.082. The resistors should be chosen from standard value resistors, a good starting point is selection in the range of 1.0k Ω - 10k Ω . Values of 5.11k Ω for R5, and 1.65k Ω for R6 were selected.

R1, R2, C12

A voltage divider can be connected to the SD pin to set a minimum operating voltage $V_{in(min)}$ for the regulator. If this feature is required, the easiest approach to select the divider resistor values is to select a value for R1 (between 10k Ω and 100k Ω recommended) then calculate R2 from:

$$R2 = 1.225 \times \left(\frac{R1}{V_{IN(min)} + (5 \times 10^{-6} \times R1) - 1.225} \right)$$

Capacitor C12 provides filtering for the divider. The voltage at the SD pin should never exceed 8V, when using an external set-point divider it may be necessary to clamp the SD pin at high input voltage conditions. The reference design utilizes the full range of the LM25576 (6V to 42V); therefore these components can be omitted. With the SD pin open circuit the LM25576 responds once the Vcc UVLO threshold is satisfied.

R7, C11

A snubber network across the power diode reduces ringing and spikes at the switching node. Excessive ringing and spikes can cause erratic operation and couple spikes and noise to the output. Voltage spikes beyond the rating of the LM25576 or the re-circulating diode can damage these devices. Selecting the values for the snubber is best accomplished through empirical methods. First, make sure the lead lengths for the snubber connections are very short. For the current levels typical for the LM25576 a resistor value between 5 and 20 Ohms is adequate. Increasing the value of the snubber capacitor results in more damping but higher losses. Select a minimum value of C11 that provides adequate damping of the SW pin waveform at high load.

R4, C5, C6

These components configure the error amplifier gain characteristics to accomplish a stable overall loop gain. One advantage of current mode control is the ability to close the loop with only two feedback components, R4 and C5. The overall loop gain is the product of the modulator gain and the error amplifier gain. The DC modulator gain of the LM25576 is as follows:

$$DC \text{ Gain}_{(MOD)} = G_{m(MOD)} \times R_{LOAD} = 2 \times R_{LOAD}$$

The dominant low frequency pole of the modulator is determined by the load resistance (R_{LOAD}) and output capacitance (C_{OUT}). The corner frequency of this pole is:

$$f_{p(MOD)} = 1 / (2\pi R_{LOAD} C_{OUT})$$

For $R_{LOAD} = 5\Omega$ and $C_{OUT} = 177\mu F$ then $f_{p(MOD)} = 180\text{Hz}$

$DC \text{ Gain}_{(MOD)} = 2 \times 5 = 10 = 20\text{dB}$

For the design example of *Figure 1* the following modulator gain vs. frequency characteristic was measured as shown in *Figure 9*.

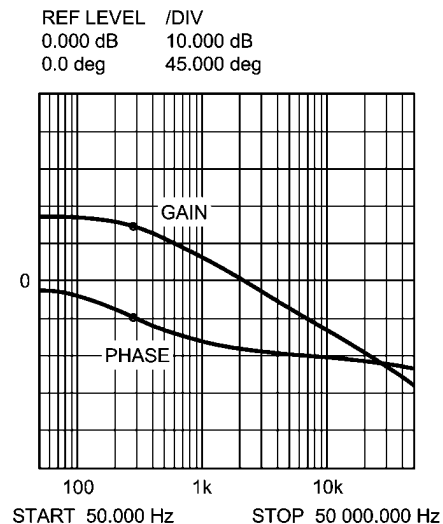

FIGURE 9. Gain and Phase of Modulator
 $R_{LOAD} = 5 \text{ Ohms}$ and $C_{OUT} = 177\mu F$

Components R4 and C5 configure the error amplifier as a type II configuration which has a pole at DC and a zero at $f_z = 1 /$

($2\pi R_4 C_5$). The error amplifier zero cancels the modulator pole leaving a single pole response at the crossover frequency of the loop gain. A single pole response at the crossover frequency yields a very stable loop with 90 degrees of phase margin.

For the design example, a target loop bandwidth (crossover frequency) of 20kHz was selected. The compensation network zero (f_z) should be selected at least an order of magnitude less than the target crossover frequency. This constrains the product of R_4 and C_5 for a desired compensation network zero $1 / (2\pi R_4 C_5)$ to be less than 2kHz. Increasing R_4 , while proportionally decreasing C_5 , increases the error amp gain. Conversely, decreasing R_4 while proportionally increasing C_5 , decreases the error amp gain. For the design example C_5 was selected for $0.01\mu\text{F}$ and R_4 was selected for $49.9\text{k}\Omega$. These values configure the compensation network zero at 320Hz. The error amp gain at frequencies greater than f_z is: R_4 / R_5 , which is approximately 10 (20dB).

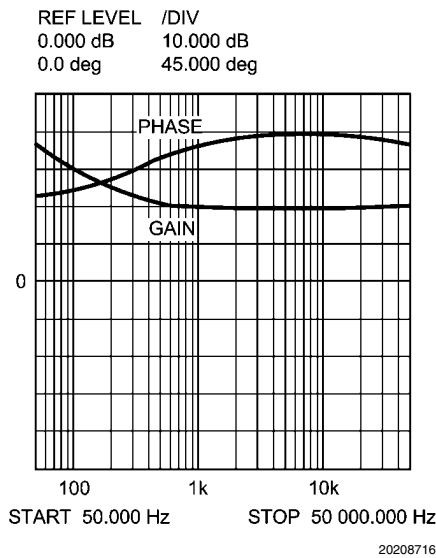

FIGURE 10. Error Amplifier Gain and Phase

The overall loop can be predicted as the sum (in dB) of the modulator gain and the error amp gain.

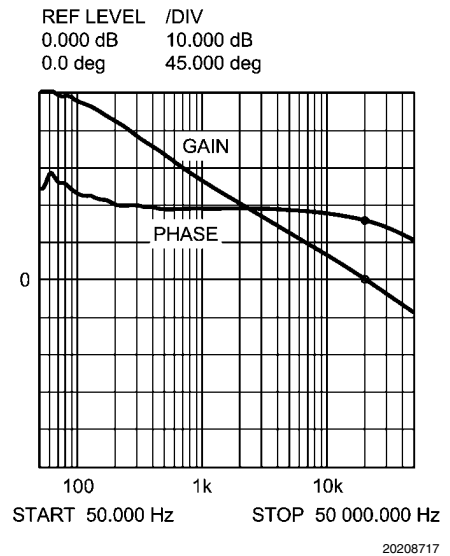
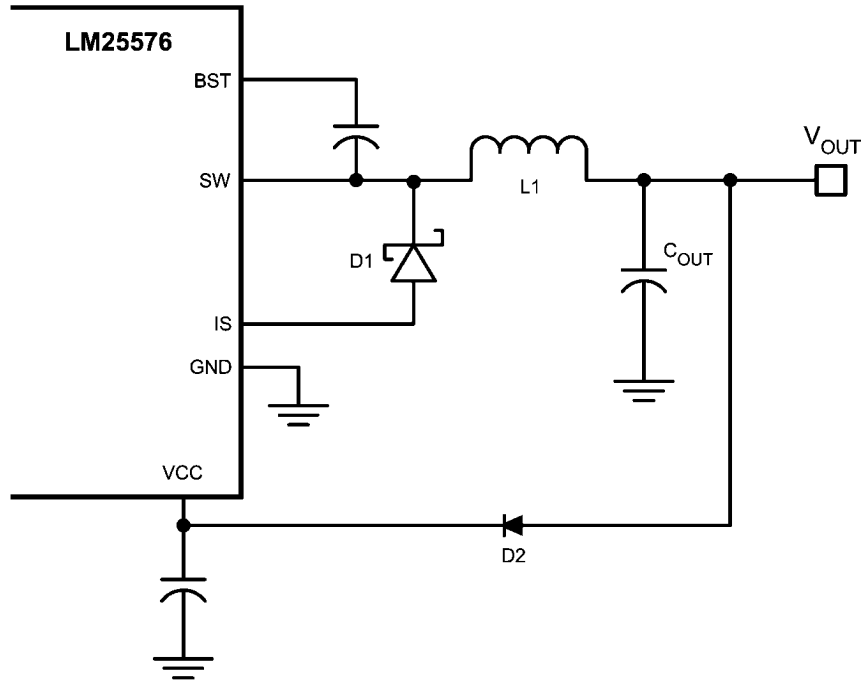

FIGURE 11. Overall Loop Gain and Phase

If a network analyzer is available, the modulator gain can be measured and the error amplifier gain can be configured for the desired loop transfer function. If a network analyzer is not available, the error amplifier compensation components can be designed with the guidelines given. Step load transient tests can be performed to verify acceptable performance. The step load goal is minimum overshoot with a damped response. C_6 can be added to the compensation network to decrease noise susceptibility of the error amplifier. The value of C_6 must be sufficiently small since the addition of this capacitor adds a pole in the error amplifier transfer function. This pole must be well beyond the loop crossover frequency. A good approximation of the location of the pole added by C_6 is: $f_{p2} = f_z \times C_5 / C_6$.

BIAS POWER DISSIPATION REDUCTION

Buck regulators operating with high input voltage can dissipate an appreciable amount of power for the bias of the IC. The V_{CC} regulator must step-down the input voltage V_{IN} to a nominal V_{CC} level of 7V. The large voltage drop across the V_{CC} regulator translates into a large power dissipation within the V_{CC} regulator. There are several techniques that can significantly reduce this bias regulator power dissipation. *Figure 12* and *Figure 13* depict two methods to bias the IC from the output voltage. In each case the internal V_{CC} regulator is used to initially bias the V_{CC} pin. After the output voltage is established, the V_{CC} pin potential is raised above the nominal 7V regulation level, which effectively disables the internal V_{CC} regulator. The voltage applied to the V_{CC} pin should never exceed 14V. The V_{CC} voltage should never be larger than the V_{IN} voltage.



20208718

FIGURE 12. VCC Bias from VOUT for $8V < V_{OUT} < 14V$

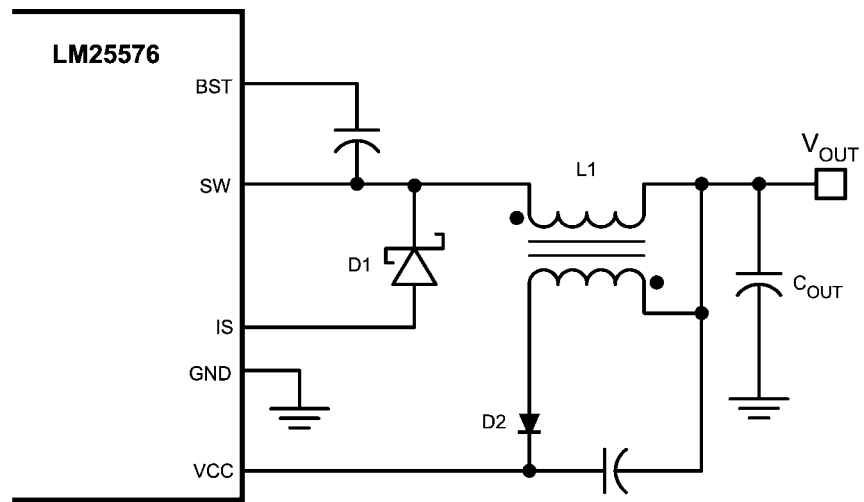

20208719

FIGURE 13. VCC Bias with Additional Winding on the Output Inductor

PCB LAYOUT AND THERMAL CONSIDERATIONS

The circuit in *Figure 13* serves as both a block diagram of the LM25576 and a typical application board schematic for the LM25576. In a buck regulator there are two loops where currents are switched very fast. The first loop starts from the input capacitors, to the regulator VIN pin, to the regulator SW pin, to the inductor then out to the load. The second loop starts from the output capacitor ground, to the regulator PGND pins, to the regulator IS pins, to the diode anode, to the inductor and then out to the load. Minimizing the loop area of these two loops reduces the stray inductance and minimizes noise and possible erratic operation. A ground plane in the PC board is recommended as a means to connect the input filter capacitors to the output filter capacitors and the PGND pins of the regulator. Connect all of the low power ground connections (C_{SS} , R_T , C_{RAMP}) directly to the regulator AGND pin. Connect the AGND and PGND pins together through the top-side copper area covering the entire underside of the device. Place several vias in this underside copper area to the ground plane.

The two highest power dissipating components are the recirculating diode and the LM25576 regulator IC. The easiest method to determine the power dissipated within the LM25576 is to measure the total conversion losses (Pin – Pout) then subtract the power losses in the Schottky diode, output inductor and snubber resistor. An approximation for the Schottky diode loss is $P = (1-D) \times I_{OUT} \times V_{fwd}$. An approximation for the output inductor power is $P = I_{OUT}^2 \times R \times 1.1$, where R is the DC resistance of the inductor and the 1.1 factor is an approximation for the AC losses. If a snubber is used, an approximation for the damping resistor power dissipation is $P = V_{in}^2 \times F_{sw} \times C_{snub}$, where F_{sw} is the switching frequency and C_{snub} is the snubber capacitor. The regulator has an exposed thermal pad to aid power dissipation. Adding

several vias under the device to the ground plane will greatly reduce the regulator junction temperature. Selecting a diode with an exposed pad will aid the power dissipation of the diode.

The most significant variables that affect the power dissipated by the LM25576 are the output current, input voltage and operating frequency. The power dissipated while operating near the maximum output current and maximum input voltage can be appreciable. The operating frequency of the LM25576 evaluation board has been designed for 300kHz. When operating at 3A output current with a 42V input the power dissipation of the LM25576 regulator is approximately 1.9W.

The junction-to-ambient thermal resistance of the LM25576 will vary with the application. The most significant variables are the area of copper in the PC board, the number of vias under the IC exposed pad and the amount of forced air cooling provided. Referring to the evaluation board artwork, the area under the LM25576 (component side) is covered with copper and there are 5 connection vias to the solder side ground plane. Additional vias under the IC will have diminishing value as more vias are added. The integrity of the solder connection from the IC exposed pad to the PC board is critical. Excessive voids will greatly diminish the thermal dissipation capacity. The junction-to-ambient thermal resistance of the LM25576 mounted in the evaluation board varies from 45°C/W with no airflow to 25°C/W with 900 LFM (Linear Feet per Minute). With a 25°C ambient temperature and no airflow, the predicted junction temperature for the LM25576 will be $25 + (45 \times 1.9) = 110^\circ\text{C}$. If the evaluation board is operated at 3A output current and 42V input voltage for a prolonged period of time the thermal shutdown protection within the IC may activate. The IC will turn off allowing the junction to cool, followed by restart with the soft-start capacitor reset to zero.

TABLE 1. 5V, 3A Demo Board Bill of Materials

ITEM		PART NUMBER	DESCRIPTION	VALUE
C	1	C4532X7R2A225M	CAPACITOR, CER, TDK	2.2 μ , 100V
C	2	C4532X7R2A225M	CAPACITOR, CER, TDK	2.2 μ , 100V
C	3	C0805C331G1GAC	CAPACITOR, CER, KEMET	330p, 100V
C	4	C2012X7R2A103K	CAPACITOR, CER, TDK	0.01 μ , 100V
C	5	C2012X7R2A103K	CAPACITOR, CER, TDK	0.01 μ , 100V
C	6	OPEN	NOT USED	
C	7	C2012X7R2A223K	CAPACITOR, CER, TDK	0.022 μ , 100V
C	8	C2012X7R1C474M	CAPACITOR, CER, TDK	0.47 μ , 16V
C	9	C3225X7R1C226M	CAPACITOR, CER, TDK	22 μ , 16V
C	10	EEFHE0J151R	CAPACITOR, SP, PANASONIC	150 μ , 6.3V
C	11	C0805C331G1GAC	CAPACITOR, CER, KEMET	330p, 100V
C	12	OPEN	NOT USED	
D	1	CSHD6-60C	DIODE, 60V, CENTRAL	
		6CWQ10FN	DIODE, 100V, IR (D1-ALT)	
L	1	DR127-330	INDUCTOR, COOPER	33 μ H
R	1	OPEN	NOT USED	
R	2	OPEN	NOT USED	
R	3	CRCW08052102F	RESISTOR	21k Ω
R	4	CRCW08054992F	RESISTOR	49.9k Ω
R	5	CRCW08055111F	RESISTOR	5.11k Ω
R	6	CRCW08051651F	RESISTOR	1.65k Ω
R	7	CRCW2512100J	RESISTOR	10, 1W
U	1	LM25576	REGULATOR, NATIONAL SEMICONDUCTOR	

PCB Layout

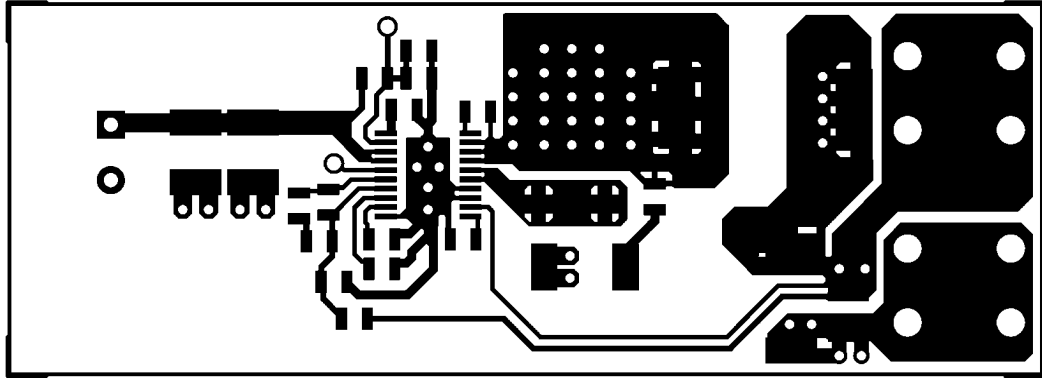

Component Side

20208729

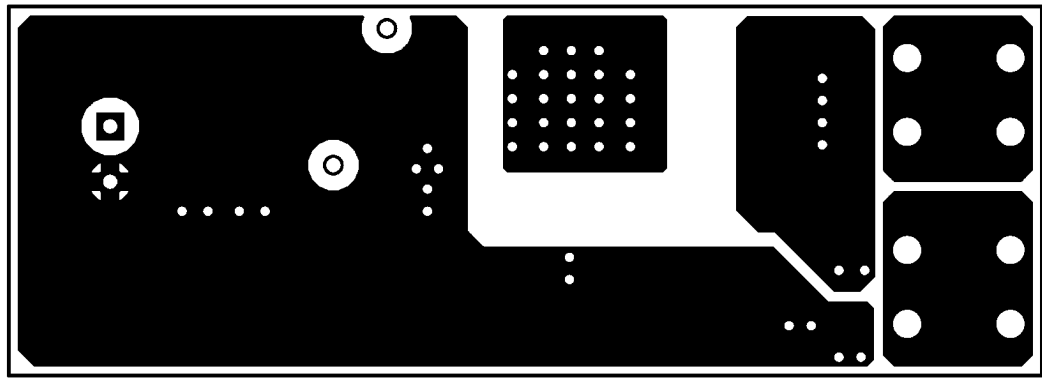

Solder Side

20208730

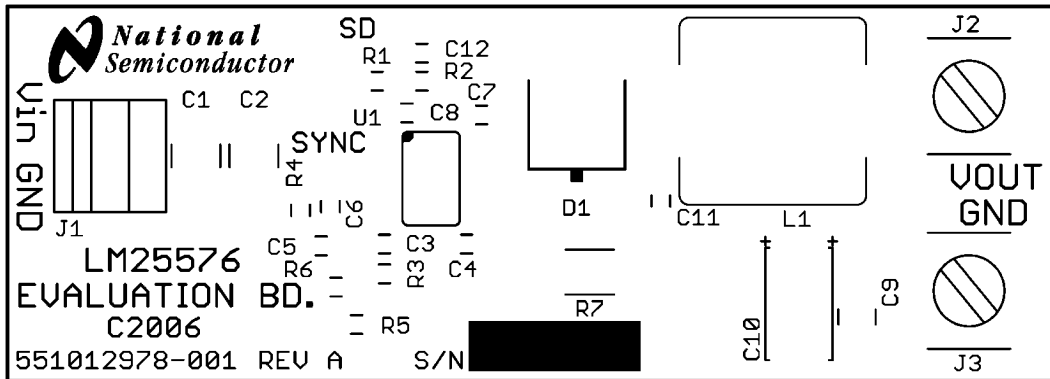

Silkscreen

20208731

Typical Schematic for High Frequency (1MHz) Application

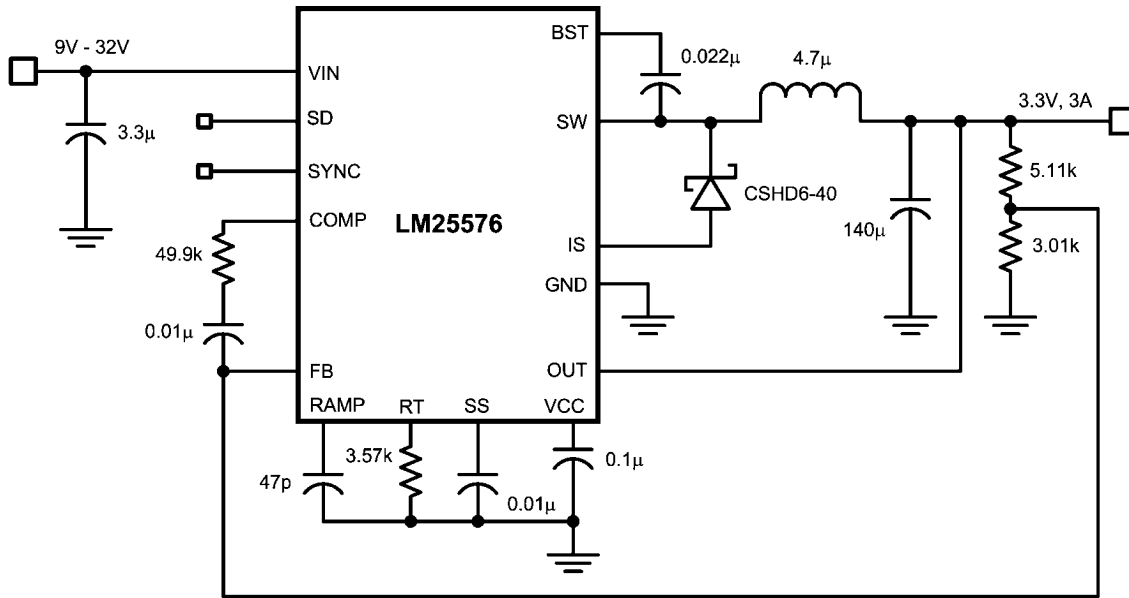

Schematic 3.3V, 3A, 1MHz

20208740

Typical Schematic for Buck/Boost (Inverting) Application

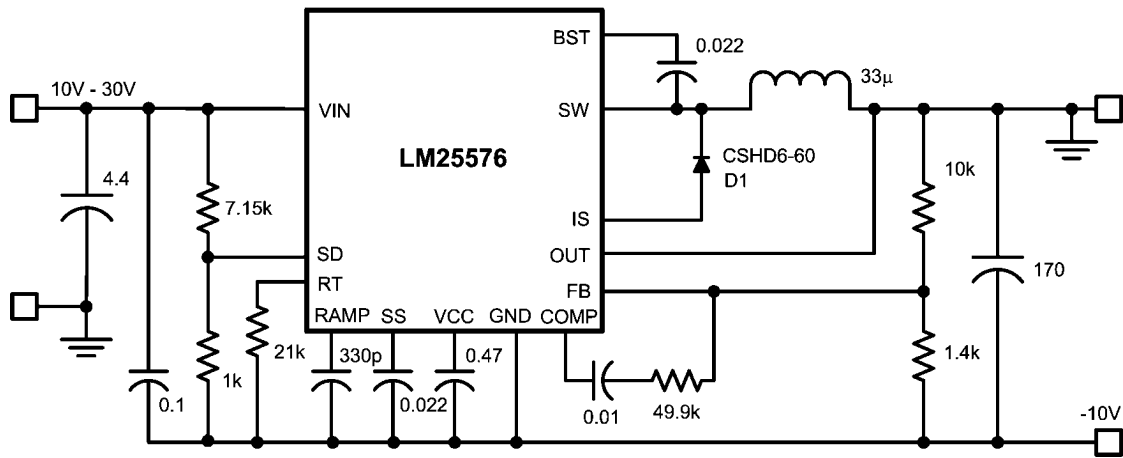

20208742

Physical Dimensions inches (millimeters) unless otherwise noted

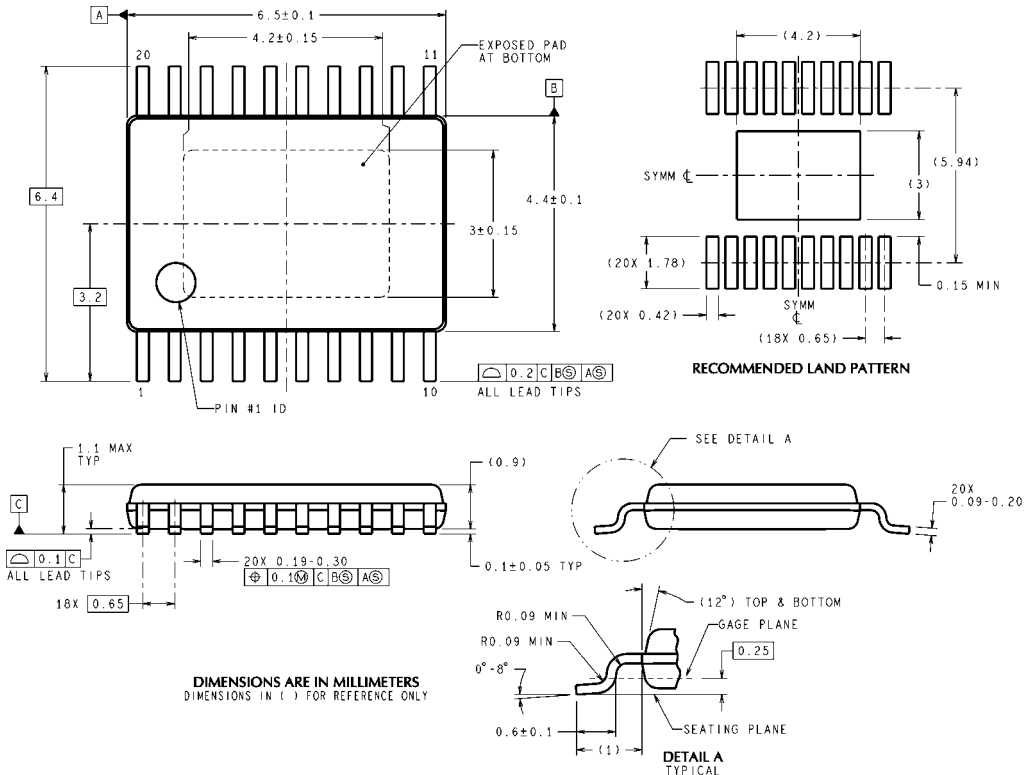

**20-Lead TSSOP Package
NS Package Number MXA20A**

MXA20A (Rev C)

Notes

LM25576

Notes

THE CONTENTS OF THIS DOCUMENT ARE PROVIDED IN CONNECTION WITH NATIONAL SEMICONDUCTOR CORPORATION ("NATIONAL") PRODUCTS. NATIONAL MAKES NO REPRESENTATIONS OR WARRANTIES WITH RESPECT TO THE ACCURACY OR COMPLETENESS OF THE CONTENTS OF THIS PUBLICATION AND RESERVES THE RIGHT TO MAKE CHANGES TO SPECIFICATIONS AND PRODUCT DESCRIPTIONS AT ANY TIME WITHOUT NOTICE. NO LICENSE, WHETHER EXPRESS, IMPLIED, ARISING BY ESTOPPEL OR OTHERWISE, TO ANY INTELLECTUAL PROPERTY RIGHTS IS GRANTED BY THIS DOCUMENT.

TESTING AND OTHER QUALITY CONTROLS ARE USED TO THE EXTENT NATIONAL DEEMS NECESSARY TO SUPPORT NATIONAL'S PRODUCT WARRANTY. EXCEPT WHERE MANDATED BY GOVERNMENT REQUIREMENTS, TESTING OF ALL PARAMETERS OF EACH PRODUCT IS NOT NECESSARILY PERFORMED. NATIONAL ASSUMES NO LIABILITY FOR APPLICATIONS ASSISTANCE OR BUYER PRODUCT DESIGN. BUYERS ARE RESPONSIBLE FOR THEIR PRODUCTS AND APPLICATIONS USING NATIONAL COMPONENTS. PRIOR TO USING OR DISTRIBUTING ANY PRODUCTS THAT INCLUDE NATIONAL COMPONENTS, BUYERS SHOULD PROVIDE ADEQUATE DESIGN, TESTING AND OPERATING SAFEGUARDS.

EXCEPT AS PROVIDED IN NATIONAL'S TERMS AND CONDITIONS OF SALE FOR SUCH PRODUCTS, NATIONAL ASSUMES NO LIABILITY WHATSOEVER, AND NATIONAL DISCLAIMS ANY EXPRESS OR IMPLIED WARRANTY RELATING TO THE SALE AND/OR USE OF NATIONAL PRODUCTS INCLUDING LIABILITY OR WARRANTIES RELATING TO FITNESS FOR A PARTICULAR PURPOSE, MERCHANTABILITY, OR INFRINGEMENT OF ANY PATENT, COPYRIGHT OR OTHER INTELLECTUAL PROPERTY RIGHT.

LIFE SUPPORT POLICY

NATIONAL'S PRODUCTS ARE NOT AUTHORIZED FOR USE AS CRITICAL COMPONENTS IN LIFE SUPPORT DEVICES OR SYSTEMS WITHOUT THE EXPRESS PRIOR WRITTEN APPROVAL OF THE CHIEF EXECUTIVE OFFICER AND GENERAL COUNSEL OF NATIONAL SEMICONDUCTOR CORPORATION. As used herein:

Life support devices or systems are devices which (a) are intended for surgical implant into the body, or (b) support or sustain life and whose failure to perform when properly used in accordance with instructions for use provided in the labeling can be reasonably expected to result in a significant injury to the user. A critical component is any component in a life support device or system whose failure to perform can be reasonably expected to cause the failure of the life support device or system or to affect its safety or effectiveness.

National Semiconductor and the National Semiconductor logo are registered trademarks of National Semiconductor Corporation. All other brand or product names may be trademarks or registered trademarks of their respective holders.

Copyright© 2007 National Semiconductor Corporation

For the most current product information visit us at www.national.com



**National Semiconductor
Americas Customer
Support Center**
Email:
new.feedback@nsc.com
Tel: 1-800-272-9959

**National Semiconductor Europe
Customer Support Center**
Fax: +49 (0) 180-530-85-86
Email: europe.support@nsc.com
Deutsch Tel: +49 (0) 69 9508 6208
English Tel: +49 (0) 870 24 0 2171
Français Tel: +33 (0) 1 41 91 8790

**National Semiconductor Asia
Pacific Customer Support Center**
Email: ap.support@nsc.com

**National Semiconductor Japan
Customer Support Center**
Fax: 81-3-5639-7507
Email: jpn.feedback@nsc.com
Tel: 81-3-5639-7560