

1A Low Dropout Positive Voltage Regulator

LM1117-XXXJ3

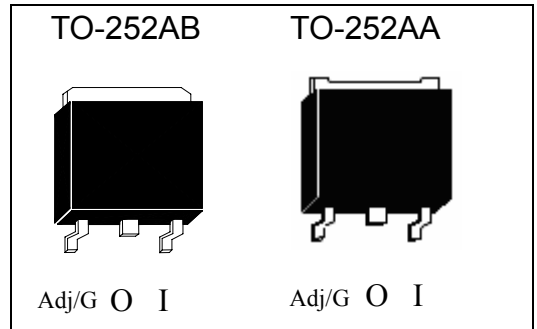

Features

- Adjustable or Fixed Output
- Output Current of 1A
- Low Dropout, 1.4V max at 1A Output Current
- Good Noise Rejection
- Output Current Limiting
- Built-in Thermal Shutdown
- Fast Transient Response

Description

The LM1117 series of positive adjustable and fixed regulators are designed to provide 1A with high efficiency. All internal circuitry is designed to operate down to 1.4V input to output differential. The product is specifically designed to provide well-regulated supply for low-voltage IC application such as high-speed bus termination and low current 3.3V logic supply, and other applications such as VGA cards.

Applications

- High Efficiency Linear Regulators
- Post Regulators for Switching Supplies
- Adjustable Power Supply

Typical Application Data

Fixed Voltage Regulator

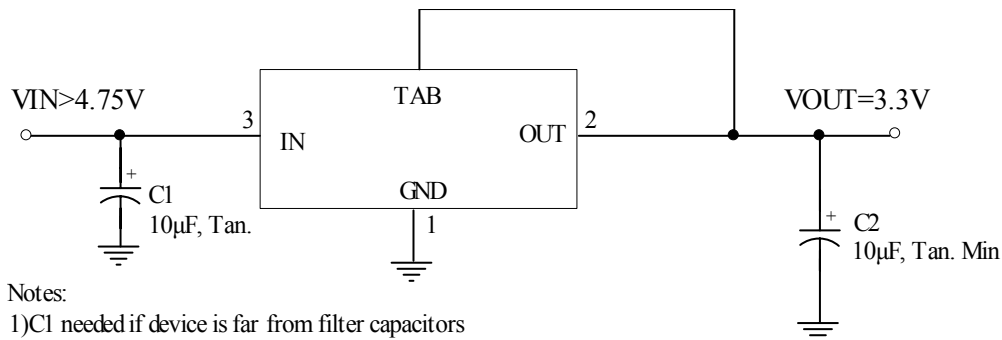

Notes:

- 1)C1 needed if device is far from filter capacitors
- 2)C2 minimum value required for stability

Adjustable Voltage Regulator

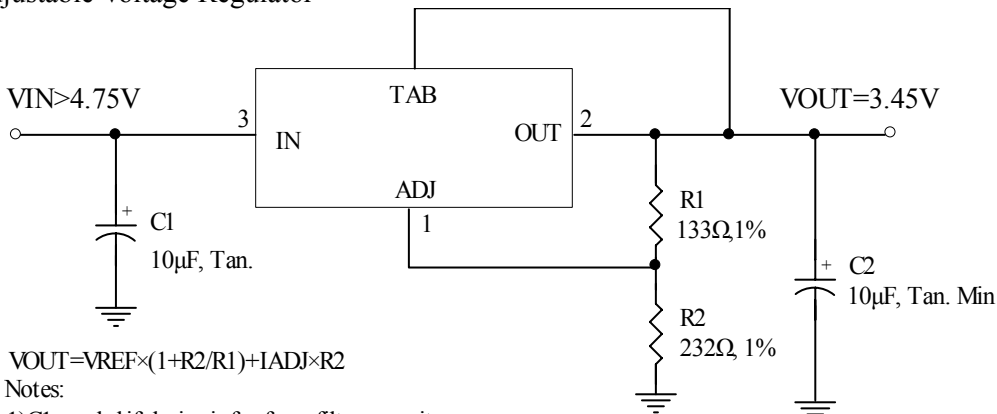

$$V_{OUT} = V_{REF} \times (1 + R_2/R_1) + I_{ADJ} \times R_2$$

Notes:

- 1)C1 needed if device is far from filter capacitors
- 2)C2 minimum value required for stability

Package Information

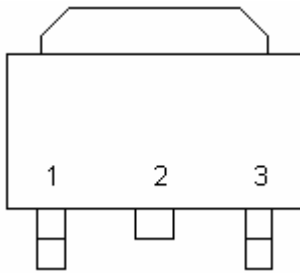

TO-252

Pin	Name
1	ADJ/GND
2	OUTPUT
3	INPUT

Absolute Maximum Ratings

Symbol	Parameter	Maximum	Units
P _D	Power Dissipation	1050	mW
V _{IN}	Input Voltage	-0.3 ~ +15	V
T _{OPR}	Operating Junction Temperature Range	0 ~ +125	°C
T _{STG}	Storage Temperature	-65 ~ +150	°C
T _{MJ}	Maximum Junction Temperature	150	°C

Device Selection Guide

Device	Output Voltage
LM1117-ADJ	Adjustable
LM1117-1.5	1.5V
LM1117-1.8	1.8V
LM1117-2.5	2.5V
LM1117-3.3	3.3V
LM1117-5.0	5.0V

Block Diagram

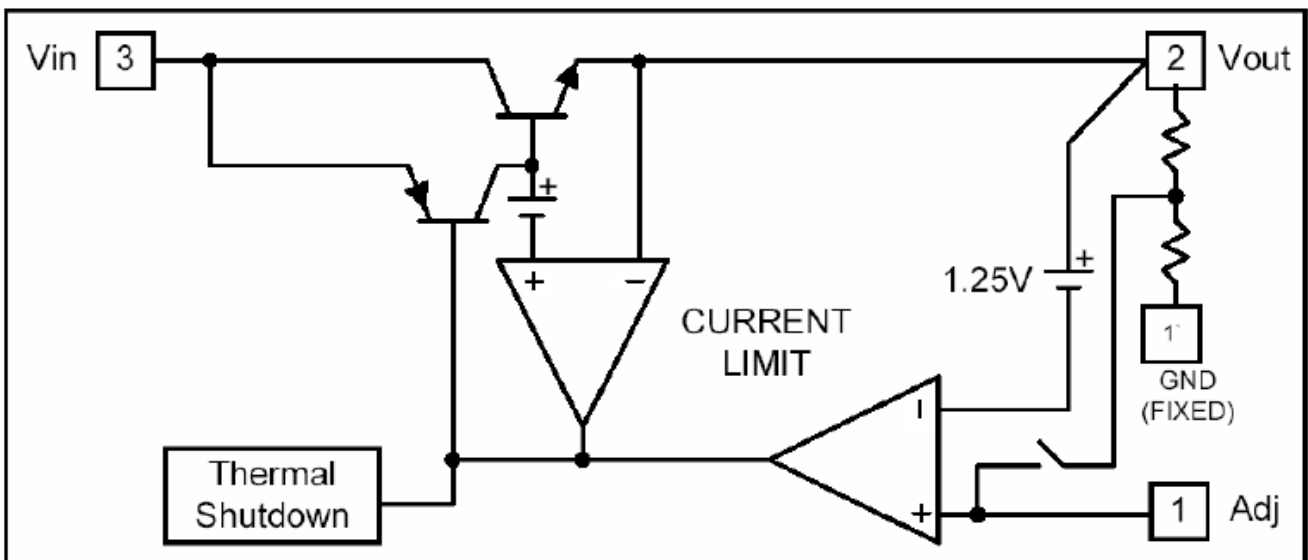

**Electrical Characteristics @ $I_o=10\text{mA}$, $T_J=25^\circ\text{C}$, unless otherwise specified**

Parameter	Device	Test Conditions	Min	Typ	Max	Units
Reference voltage	Adj version	$V_{IN}-V_{OUT}=1.5\text{V}$	1.225	1.250	1.275	V
Output Voltage	LM1117-1.5	$3.0\text{V}\leq V_{IN}\leq 12\text{V}$	1.470	1.500	1.530	V
	LM1117-1.8	$3.3\text{V}\leq V_{IN}\leq 12\text{V}$	1.764	1.800	1.836	V
	LM1117-2.5	$4.0\text{V}\leq V_{IN}\leq 12\text{V}$	2.450	2.500	2.550	V
	LM1117-3.3	$4.8\text{V}\leq V_{IN}\leq 12\text{V}$	3.235	3.300	3.365	V
	LM1117-5.0	$6.5\text{V}\leq V_{IN}\leq 12\text{V}$	4.900	5.000	5.100	V
Line Regulation	All version	$V_{OUT}+1.5\text{V}\leq V_{IN}\leq 12\text{V}$	-	-	0.2	%
Load Regulation (Note 1, 2)	LM1117-ADJ	$V_{IN}=3.3\text{V}$, $V_{adj}=0$, $10\text{mA}\leq I_o\leq 1\text{A}$	-	-	1	%
	LM1117-1.5	$V_{IN}=3.0\text{V}$, $0\text{mA}\leq I_o\leq 1\text{A}$	-	12	15	mV
	LM1117-1.8	$V_{IN}=3.3\text{V}$, $0\text{mA}\leq I_o\leq 1\text{A}$	-	15	18	mV
	LM1117-2.5	$V_{IN}=4.0\text{V}$, $0\text{mA}\leq I_o\leq 1\text{A}$	-	20	25	mV
	LM1117-3.3	$V_{IN}=5.0\text{V}$, $0\text{mA}\leq I_o\leq 1\text{A}$	-	26	33	mV
	LM1117-5.0	$V_{IN}=8.0\text{V}$, $0\text{mA}\leq I_o\leq 1\text{A}$	-	40	50	mV
Dropout Voltage ($V_{IN}-V_{OUT}$)	All version	$I_o=1\text{A}$ ($\Delta V_{OUT}=1\%V_{OUT}$)	-	1.3	1.4	V
Current Limit	All version	$V_{IN}-V_{OUT}=5\text{V}$	1.1	-	-	A
Minimum Load Current	Adj version	$V_{IN}=5\text{V}$	-	5	10	mA
Adjust Pin Current	Adj version	$V_{IN}=12\text{V}$, $I_o=10\text{mA}$	-	50	100	μA
Quiescent Current	Fixed version	$V_{IN}=12\text{V}$, $I_o=0\text{mA}$	-	-	12	mA
Thermal Regulation	All version	$T_A=25^\circ\text{C}$, 30ms pulse	-	0.008	0.04	%/W
Ripple Rejection	All version	$f=120\text{Hz}$, $V_{IN}=V_{OUT}+3\text{V}$, $I_o=1\text{A}$, $C_{OUT}=25\mu\text{F}$ tantalum	60	70	-	dB
Temperature Stability	All version	$I_o=10\text{mA}$	-	0.5	-	%
Thermal Resistance, Junction to Ambient (No heat sink, no air flow)	All version		-	117	-	$^\circ\text{C}/\text{W}$
Thermal Resistance, Junction to Case	All version	Control Circuitry/ Power transistor	-	15	-	$^\circ\text{C}/\text{W}$

- Note : 1. See thermal regulation specifications for changes in output voltage due to heating effects. Line and load regulation are measured at a constant junction temperature by low duty cycle pulse testing. Load regulation is measured at the output lead 1/18" from the package.
2. Line and load regulation are guaranteed up to the maximum power dissipation of 15W. Power dissipation is determined by the difference in input and output and the output current. Guaranteed maximum power dissipation will not be available over the full input/output range.

Moisture Sensitivity Level : conform to JEDEC level 3

Recommended Storage Condition:

Temperature : $\leq 30^\circ\text{C}$ Humidity : $\leq 60\% \text{RH}$

Characteristic Curves

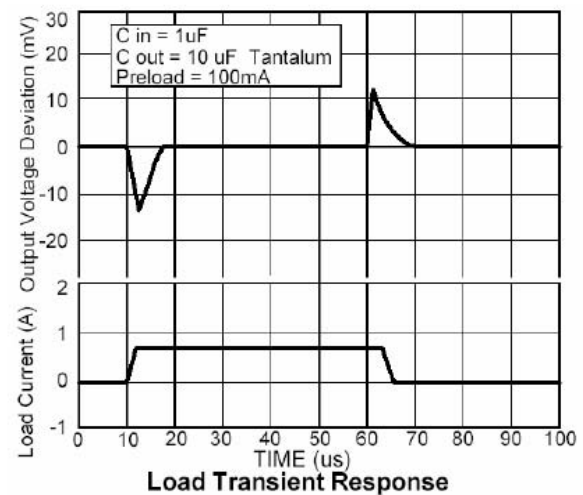
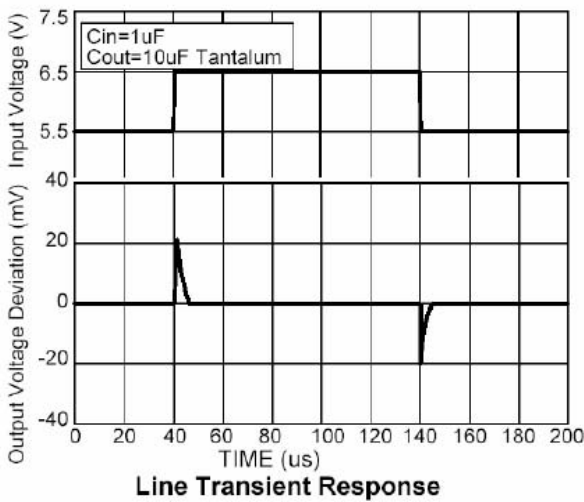
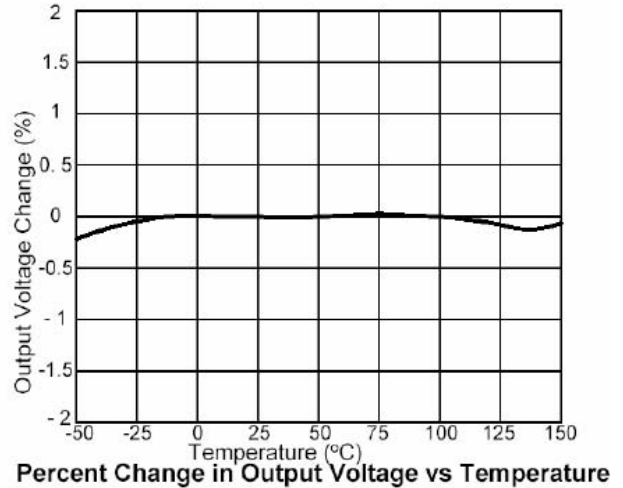
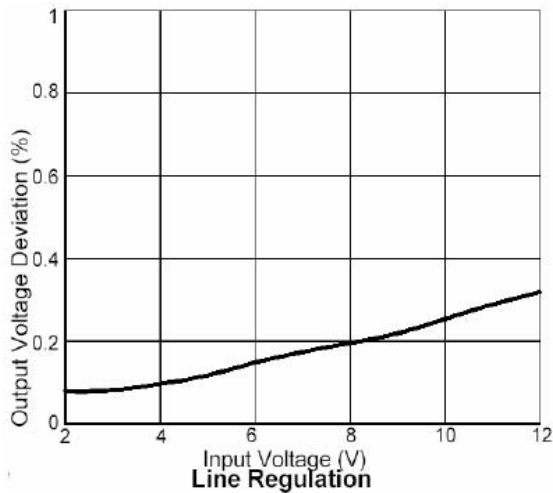
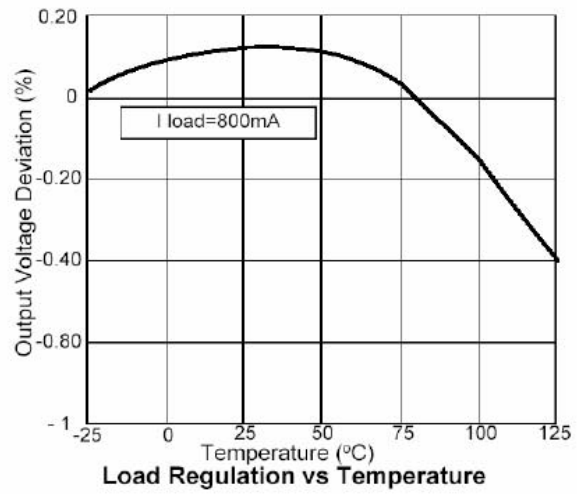
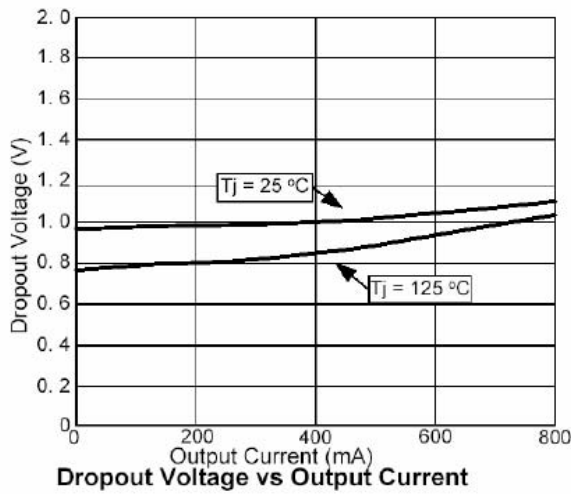

Reel Dimension

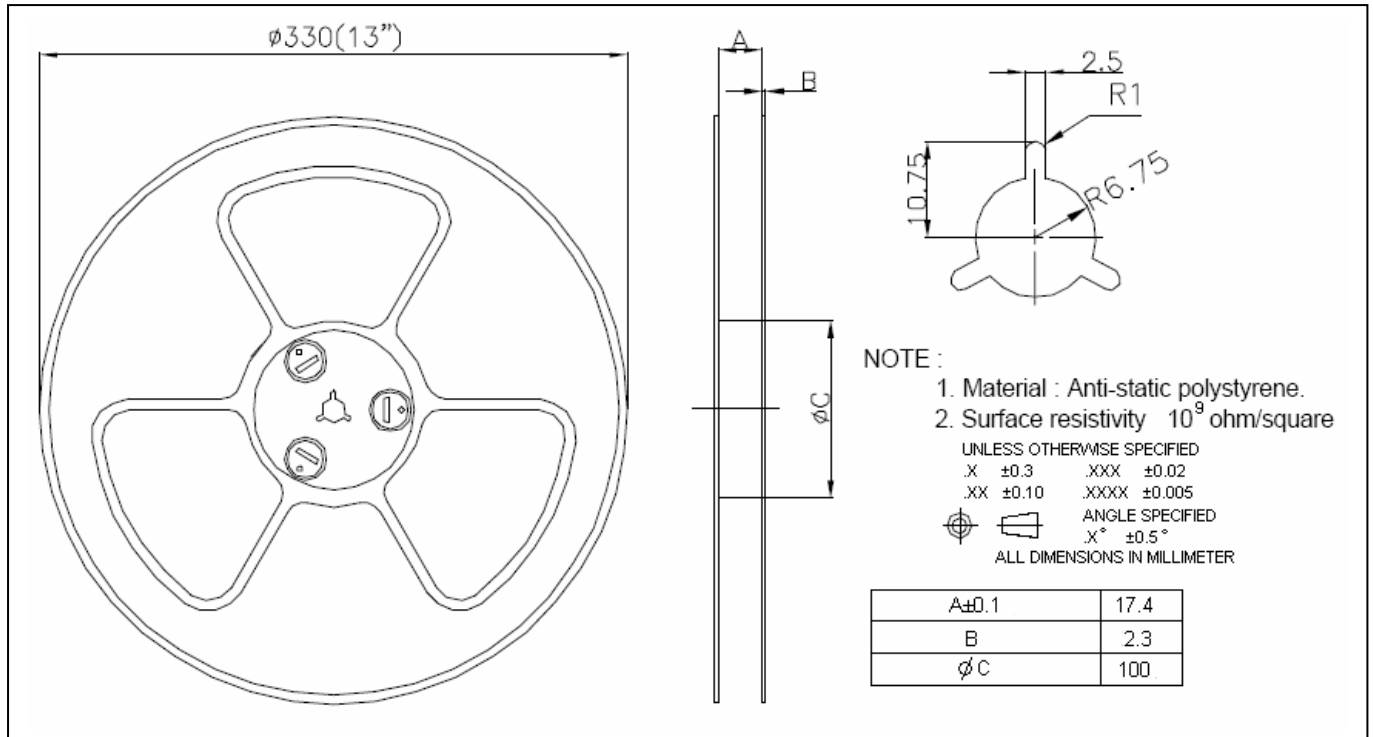

Carrier Tape Dimension

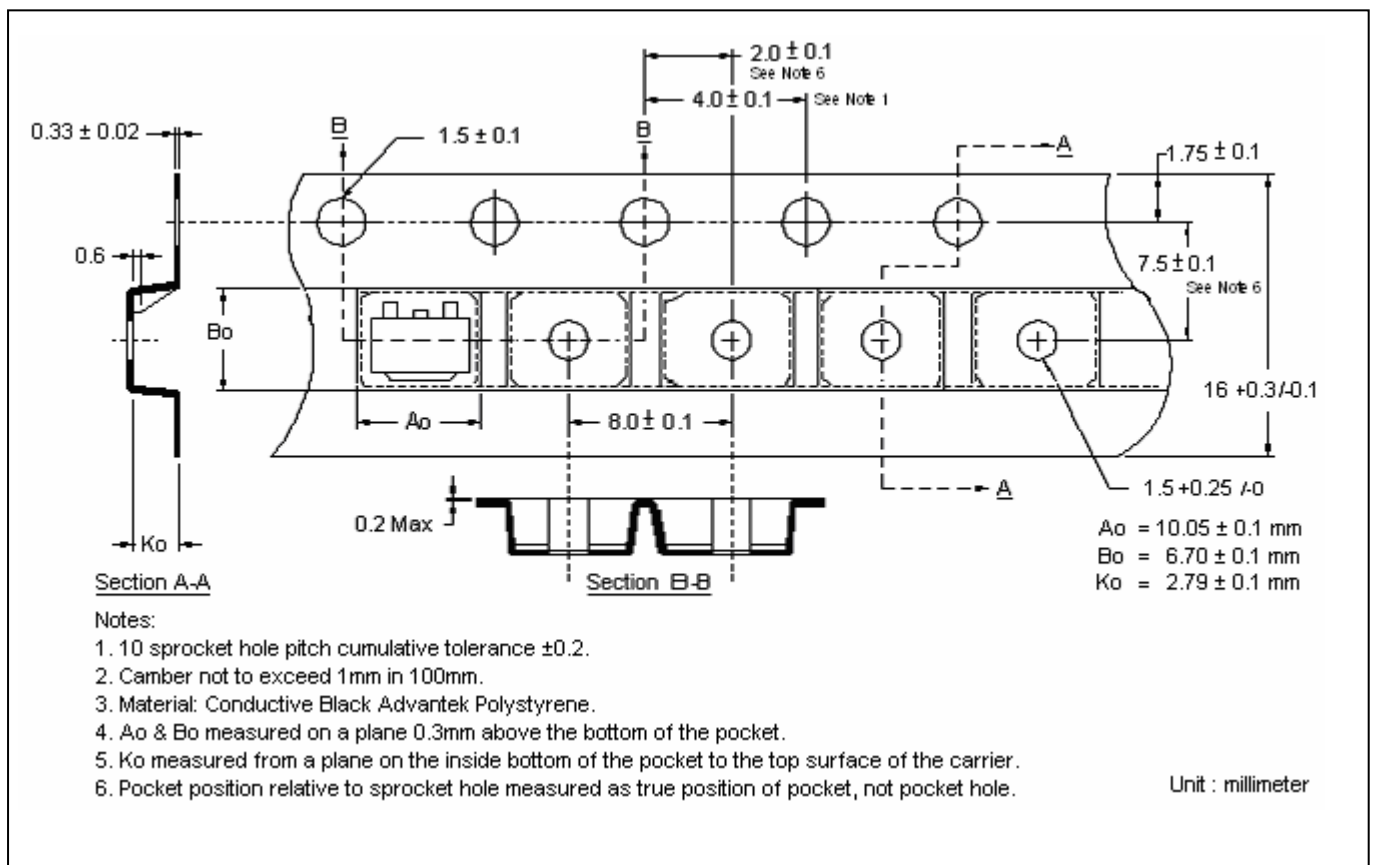

Recommended wave soldering condition

Product	Peak Temperature	Soldering Time
Pb-free devices	260 +0/-5 °C	5 +1/-1 seconds

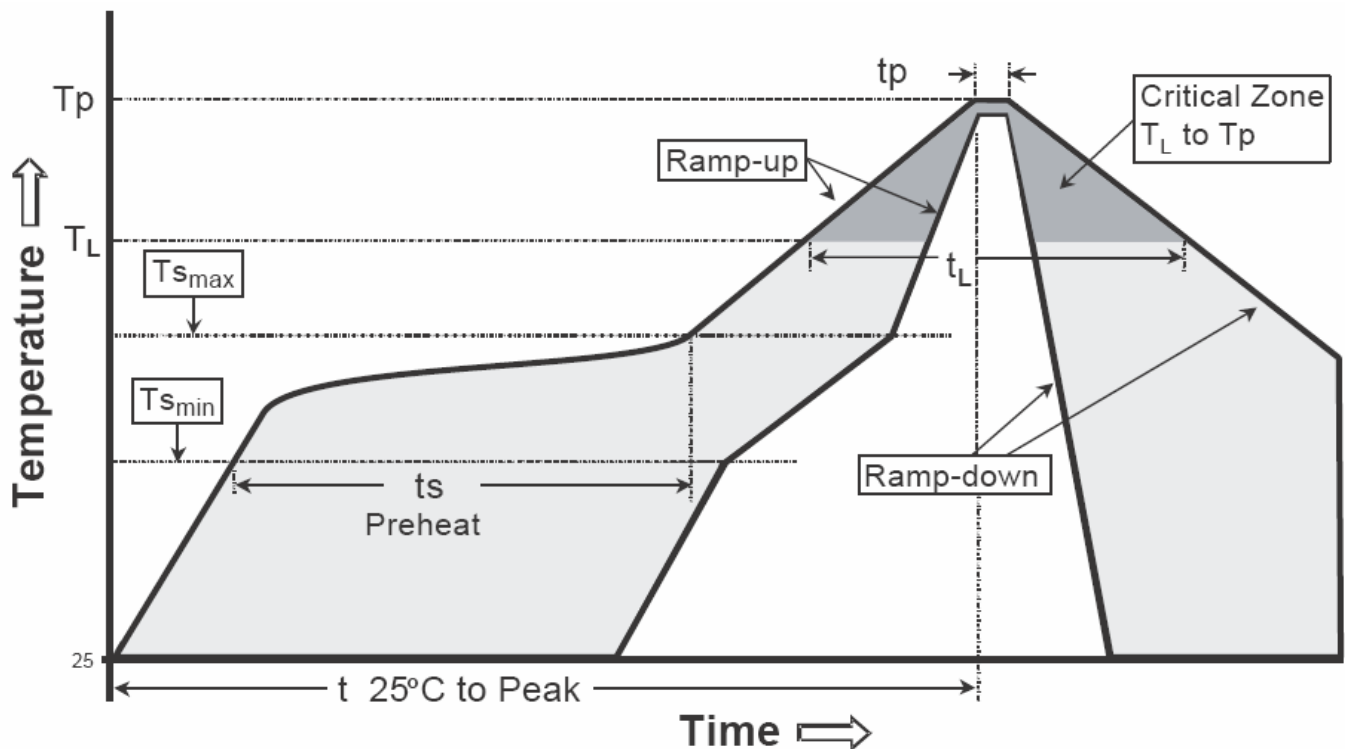
Recommended temperature profile for IR reflow

Profile feature	Sn-Pb eutectic Assembly	Pb-free Assembly
Average ramp-up rate (Tsmax to Tp)	3°C/second max.	3°C/second max.
Preheat		
-Temperature Min(Ts min)	100°C	150°C
-Temperature Max(Ts max)	150°C	200°C
-Time(ts min to ts max)	60-120 seconds	60-180 seconds
Time maintained above:		
-Temperature (Tl)	183°C	217°C
- Time (tl)	60-150 seconds	60-150 seconds
Peak Temperature(Tp)	240 +0/-5 °C	260 +0/-5 °C
Time within 5°C of actual peak temperature(tp)	10-30 seconds	20-40 seconds
Ramp down rate	6°C/second max.	6°C/second max.
Time 25 °C to peak temperature	6 minutes max.	8 minutes max.

Note : All temperatures refer to topside of the package, measured on the package body surface.

TO-252AB Dimension

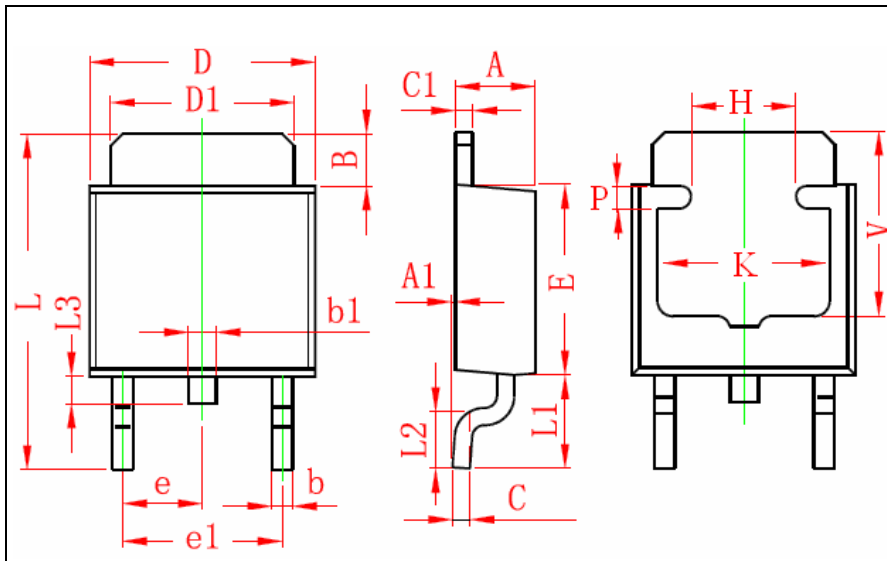

The diagram shows three views of the TO-252AB package: a top view, a side view, and a bottom view. Dimensions are labeled with letters A through V. The top view shows dimensions D, D1, B, L, L3, b1, e, e1, and b. The side view shows dimensions C1, A, A1, E, L1, L2, and C. The bottom view shows dimensions H, K, and V.

Marking:

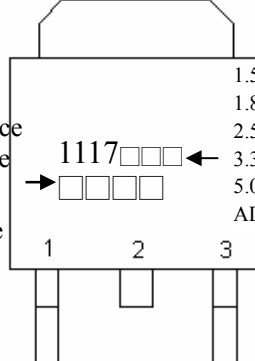

Device Name: 1117□□□□ ←

Date Code: □□□□ →

Pin 1: 1.5V → -15

Pin 2: 1.8V → -18

Pin 3: 2.5V → -25

Pin 4: 3.3V → -33

Pin 5: 5.0V → -50

Pin 6: ADJ → blank

3-Lead TO-252AB Plastic Surface Mount Package
 CYStek Package Code: J3

Style: Pin 1.Vin 2.Ground 3.Vout
 4.Ground

*: Typical

DIM	Inches		Millimeters		DIM	Inches		Millimeters	
	Min.	Max.	Min.	Max.		Min.	Max.	Min.	Max.
A	0.087	0.094	2.200	2.400	e	*0.091		*2.300	
A1	0.000	0.005	0.000	0.127	e1	0.177	0.185	4.500	4.700
B	0.053	0.065	1.350	1.650	H	0.118	REF	3.000	REF
b	0.020	0.028	0.500	0.700	K	0.197	REF	5.000	REF
b1	0.028	0.035	0.700	0.900	L	0.374	0.390	9.500	9.900
C	0.017	0.023	0.430	0.580	L1	0.100	0.114	2.550	2.900
C1	0.017	0.023	0.430	0.580	L2	0.055	0.070	1.400	1.780
D	0.250	0.262	6.350	6.650	L3	0.024	0.035	0.600	0.900
D1	0.205	0.213	5.200	5.400	P	0.028	REF	0.700	REF
E	0.213	0.224	5.400	5.700	V	0.209	REF	5.300	REF

Notes: 1.Controlling dimension: millimeters.
 2.Maximum lead thickness includes lead finish thickness, and minimum lead thickness is the minimum thickness of base material.
 3.If there is any question with packing specification or packing method, please contact your local CYStek sales office.

Material:

- Lead : Pure tin plated
- Mold Compound: Epoxy resin family, flammability solid burning class: UL94V-0

TO-252AA Dimension

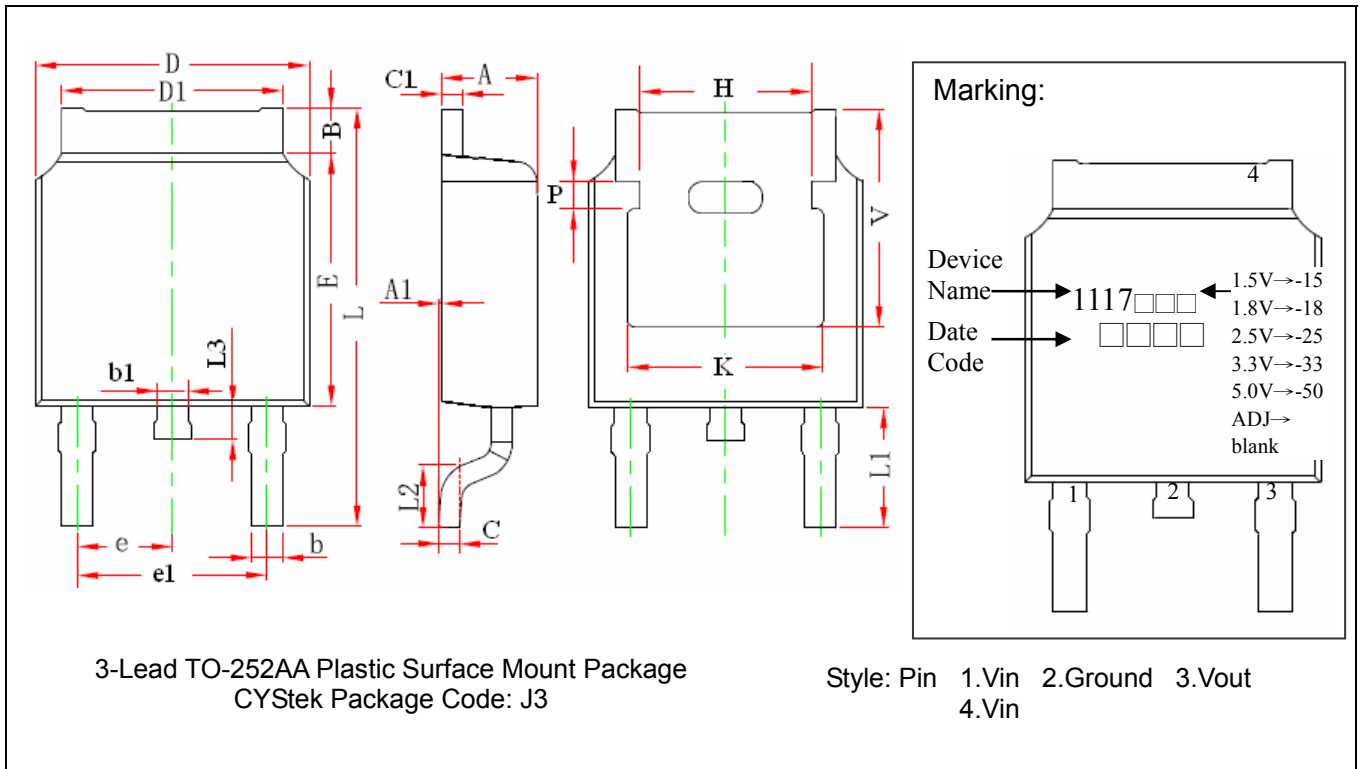

3-Lead TO-252AA Plastic Surface Mount Package
 CYStek Package Code: J3

Style: Pin 1.Vin 2.Ground 3.Vout
 4.Vin

Device Name	1.5V→-15
1117	1.8V→-18
	2.5V→-25
	3.3V→-33
	5.0V→-50
	ADJ→
	blank

DIM	Inches		Millimeters		DIM	Inches		Millimeters	
	Min.	Max.	Min.	Max.		Min.	Max.	Min.	Max.
A	0.087	0.094	2.200	2.400	e	0.086	0.094	2.186	2.386
A1	0.000	0.005	0.000	0.127	e1	0.172	0.188	4.372	4.772
B	0.039	0.048	0.990	1.210	H	0.163	REF	4.140	REF
b	0.026	0.034	0.660	0.860	K	0.190	REF	4.830	REF
b1	0.026	0.034	0.660	0.860	L	0.386	0.409	9.800	10.400
C	0.018	0.023	0.460	0.580	L1	0.114	REF	2.900	REF
C1	0.018	0.023	0.460	0.580	L2	0.055	0.067	1.400	1.700
D	0.256	0.264	6.500	6.700	L3	0.024	0.039	0.600	1.000
D1	0.201	0.215	5.100	5.460	P	0.026	REF	0.650	REF
E	0.236	0.244	6.000	6.200	V	0.211	REF	5.350	REF

Notes: 1.Controlling dimension: millimeters.
 2.Maximum lead thickness includes lead finish thickness, and minimum lead thickness is the minimum thickness of base material.
 3.If there is any question with packing specification or packing method, please contact your local CYStek sales office.

Material:

- Lead : Pure tin plated.
- Mold Compound: Epoxy resin family, flammability solid burning class: UL94V-0.

Important Notice:

- All rights are reserved. Reproduction in whole or in part is prohibited without the prior written approval of CYStek.
- CYStek reserves the right to make changes to its products without notice.
- CYStek **semiconductor products are not warranted to be suitable for use in Life-Support Applications, or systems.**
- CYStek assumes no liability for any consequence of customer product design, infringement of patents, or application assistance.