

3 A very low drop-out voltage regulator

Features

- Input voltage range:
 - $V_I = 1.4\text{ V to }5.5\text{ V}$
 - $V_{BIAS} = 3\text{ V to }6\text{ V}$
- Stable with ceramic capacitor
- $\pm 1.5\%$ initial tolerance
- Maximum dropout voltage ($V_I - V_O$) of 400 mV over temperature
- Adjustable output voltage down to 0.8 V
- Ultra fast transient response (up to 10 MHz bandwidth)
- Excellent line and load regulation specifications
- Logic controlled shutdown option
- Thermal shutdown and current limit protection
- Junction temperature range: $-25\text{ }^\circ\text{C to }125\text{ }^\circ\text{C}$

Applications

- Graphics processors
- PC add-in cards
- Microprocessor core voltage supply
- Low voltage digital ICs
- High efficiency linear power supplies
- SMPS post regulators

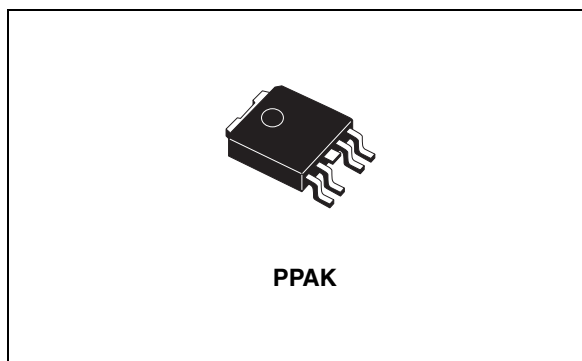

Description

The LD49300xx is a high-bandwidth, low drop-out, 3.0 A voltage regulator, ideal for powering core voltages of low-power microprocessors. The LD49300xx implements a dual supply configuration allowing for very low output impedance and very fast transient response. The LD49300xx requires a bias input supply and a main input supply, allowing for ultra-low input voltages on the main supply rail. The input supply operates from 1.4 V to 5.5 V and the bias supply requires between 3 V and 6 V for proper operation. The LD49300xx offers fixed output voltages from 0.8 V to 1.8 V and adjustable output voltages down to 0.8 V. The LD49300xx requires a minimum output capacitance for stability, and works optimally with small ceramic capacitors.

Table 1. Device summary

Order codes	Package	Packaging
LD49300PT08R ⁽¹⁾	PPAK (Tape and reel)	2500 parts per reel
LD49300PT10R	PPAK (Tape and reel)	2500 parts per reel
LD49300PT12R	PPAK (Tape and reel)	2500 parts per reel

1. Adjustable version.

Contents

1	Typical application circuits	3
2	Alternative application circuits	4
3	Pin configuration	5
4	Diagram	6
5	Maximum ratings	7
6	Electrical characteristics	8
7	Typical characteristics	9
8	Application hints	13
8.1	Input supply voltage (V_{IN})	13
8.2	Bias supply voltage (V_{BIAS})	13
8.3	External capacitors	13
8.4	Output capacitor	13
8.5	Minimum load current	13
8.6	Power sequencing recommendations	14
8.7	Power dissipation/heatsinking	14
8.8	Heatsinking PPAK package	15
8.9	Adjustable regulator design	15
8.10	Enable	15
9	Package mechanical data	16
10	Revision history	19

1 Typical application circuits

Figure 1. Adjustable version

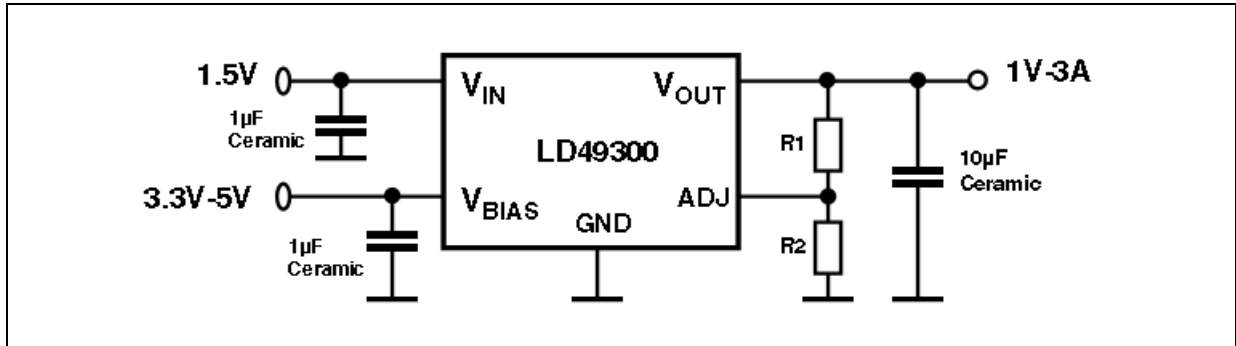
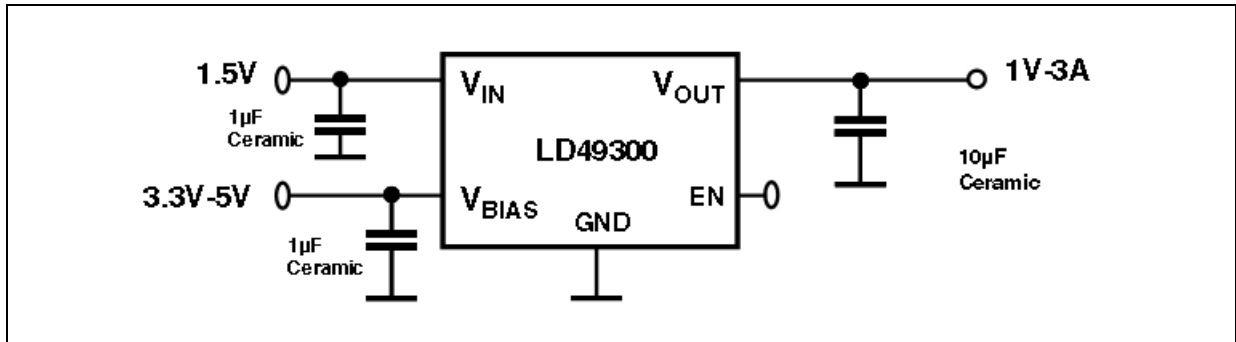

Figure 2. Fixed version with enable



2 Alternative application circuits

Figure 3. Single supply voltage solution

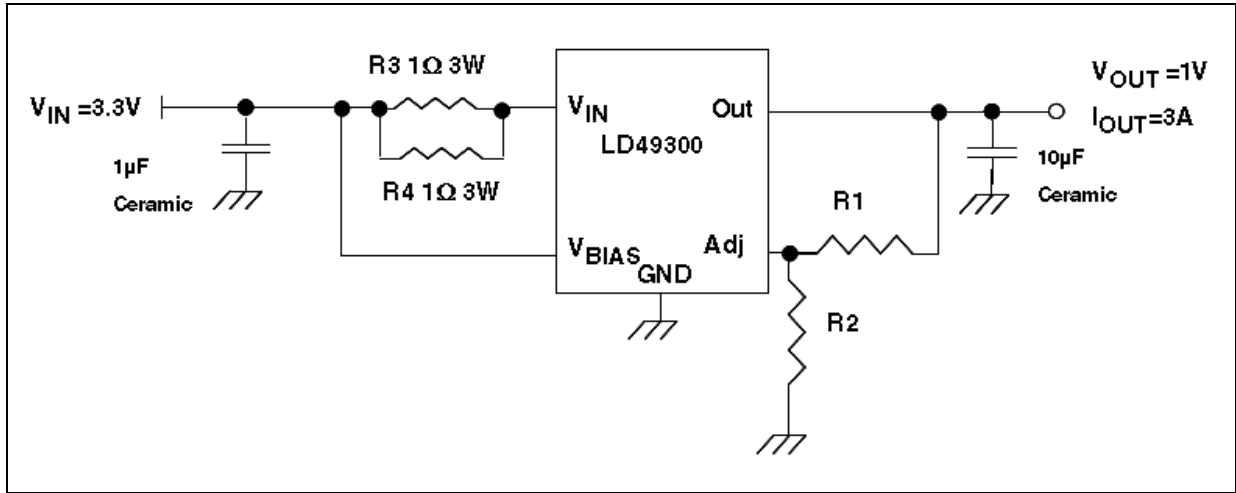
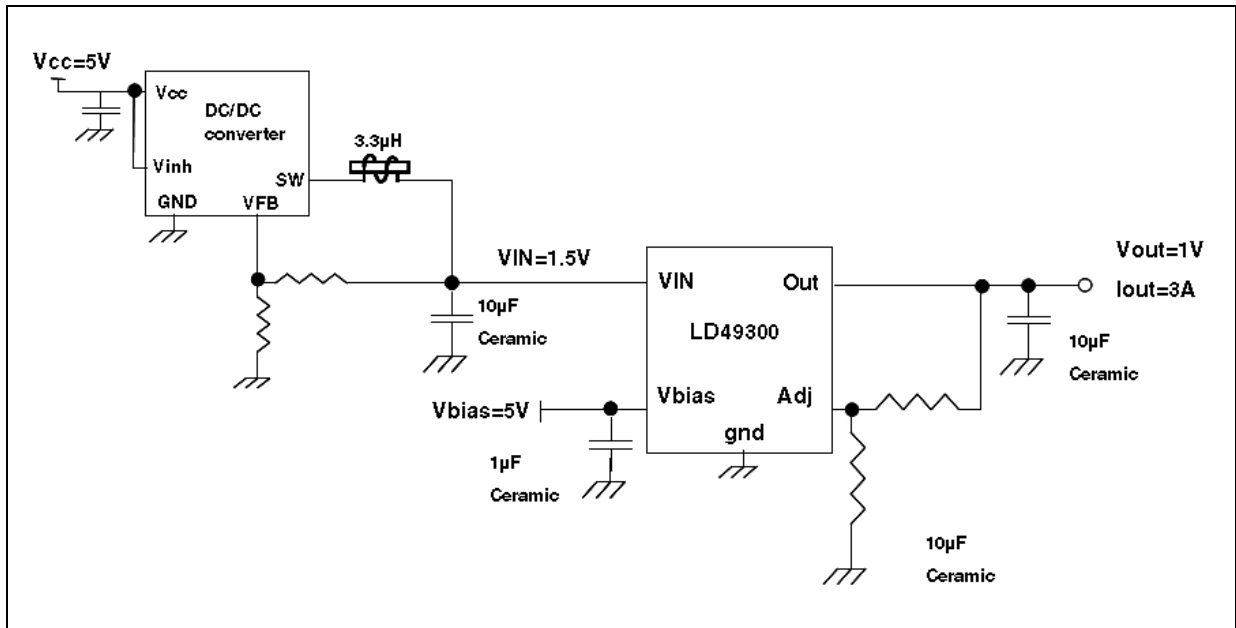

Figure 4. LD49300xx plus DC-DC pre-regulator to reduce power dissipation



3 Pin configuration

Figure 5. Pin connections (top view)

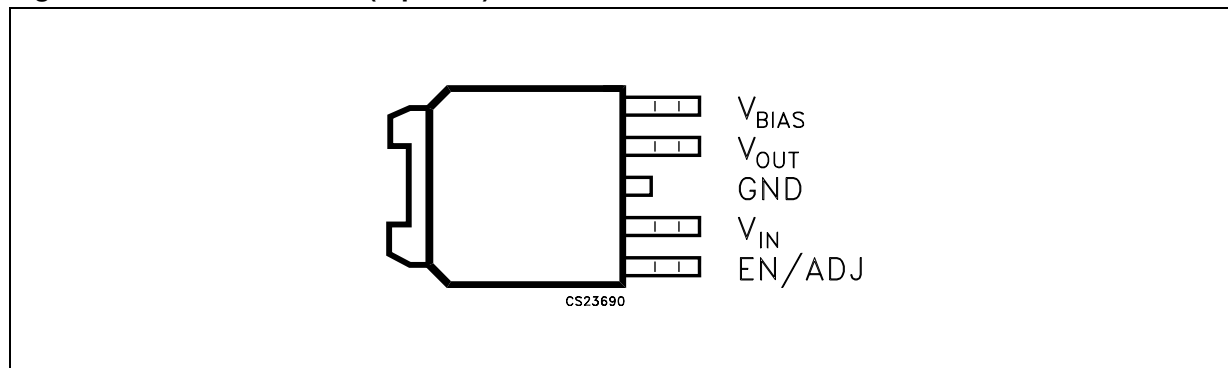
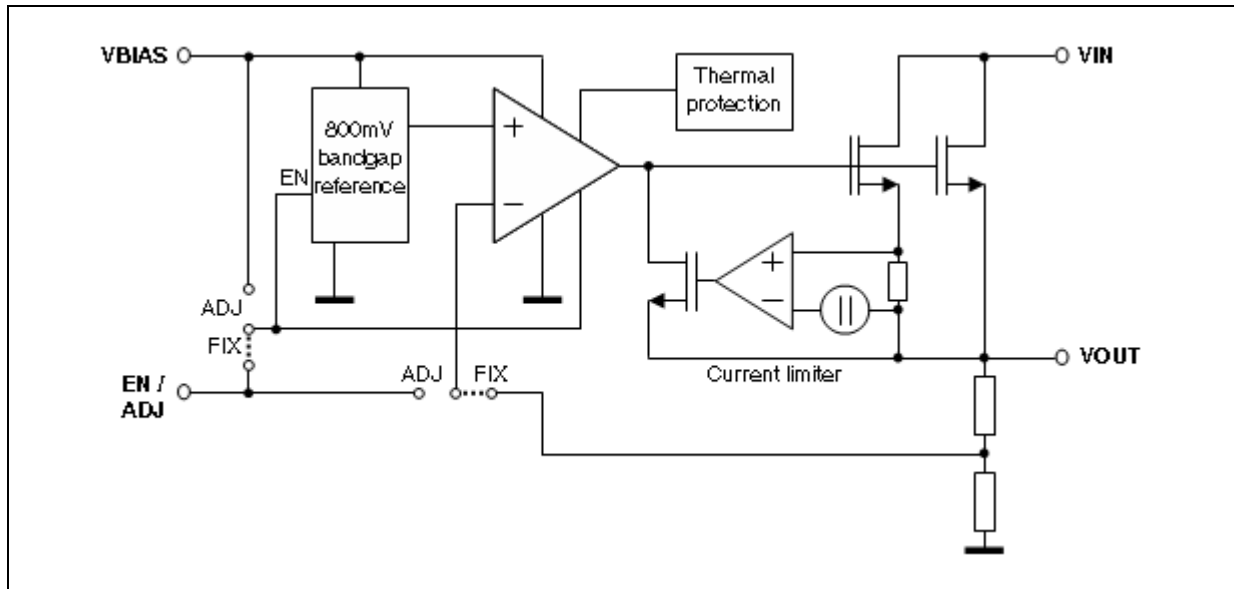

Table 2. Pin description

Pin n°	Symbol	Note
1	EN	Enable (Input): Logic High = Enable, Logic Low = Shutdown.
	ADJ	Adjustable regulator feedback input. Connect to resistor voltage divider.
2	V_{IN}	Input voltage which supplies current to the output power device.
3	GND	Ground (TAB is connected to ground).
4	V_{OUT}	Regulator output.
5	V_{BIAS}	Input bias voltage for powering all circuitry on the regulator with the exception of the output power device.

4 Diagram

Figure 6. Block diagram



5 Maximum ratings

Table 3. Absolute maximum ratings

Symbol	Parameter	Value	Unit
V_{IN}	Supply voltage	-0.3 to 7	V
V_{OUT}	Output voltage	-0.3 to $V_{IN} + 0.3$ -0.3 to $V_{BIAS} + 0.3$	V
V_{BIAS}	BIAS Supply voltage	-0.3 to 7	V
V_{EN}	Enable input voltage	-0.3 to 7	V
P_D	Power dissipation	Internally Limited	
T_{STG}	Storage temperature range	-50 to 150	°C

Note: 1 Absolute maximum ratings are those values beyond which damage to the device may occur. Functional operation under these conditions is not implied.

2 All the values are referred to ground.

Table 4. Operating ratings

Symbol	Parameter	Value	Unit
V_{IN}	Supply voltage	1.4 to 5.5	V
V_{OUT}	Output voltage	0.8 to 4.5	V
V_{BIAS}	BIAS Supply voltage	3 to 6	V
V_{EN}	Enable input voltage	0 to V_{BIAS}	V
T_J	Junction temperature range	-25 to 125	°C

6 Electrical characteristics

($T_J = -25\text{ °C}$ to 125 °C , $V_{BIAS} = V_O + 2.1\text{ V}$ ⁽¹⁾; $V_I = V_O + 1\text{ V}$; $V_{EN} = V_{BIAS}$ ⁽²⁾, $I_O = 10\text{ mA}$; $C_I = 1\text{ }\mu\text{F}$; $C_O = 10\text{ }\mu\text{F}$; $C_{BIAS} = 1\text{ }\mu\text{F}$; unless otherwise specified. Typical values are referred to $T_J = 25\text{ °C}$).

Table 5. Electrical characteristics

Symbol	Parameter	Test conditions	Min.	Typ.	Max.	Unit
V_O	Output voltage accuracy	$T_J = 25\text{ °C}$, fixed voltage options	-1.5		1.5	%
		Over temperature range	-3		3	
V_{LINE}	Line regulation	$V_I = V_O + 1\text{ V}$ to 5.5 V	-0.1		0.1	%/V
V_{LOAD}	Load regulation	$I_L = 0\text{ mA}$ to 3 A , $V_{BIAS} \geq 3\text{ V}$			1	%
V_{DROP}	Dropout voltage ($V_I - V_O$)	$I_L = 1.5\text{ A}$			200	mV
		$I_L = 3\text{ A}$			400	
V_{DROP}	Dropout voltage ($V_{BIAS} - V_O$)	$I_L = 3\text{ A}$ ⁽¹⁾		1.5	2.1	V
I_{GND}	Ground pin current	$I_L = 0\text{ mA}$		4	6	mA
		$I_L = 3\text{ A}$		4	6	
I_{GND_SHD}	Ground pin current in shutdown	$V_{EN} \leq 0.4\text{ V}$ ⁽²⁾			5	μA
I_{VBIAS}	Current through V_{BIAS}	$I_L = 0\text{ mA}$		3	5	mA
		$I_L = 3\text{ A}$		3	5	
I_L	Current limit	$V_O = 0\text{ V}$	4.5			A
Enable input ⁽²⁾						
V_{EN}	Enable input threshold (fixed voltage only)	Regulator Enable	1.4			V
		Regulator Shutdown			0.4	
I_{EN}	Enable pin input current			0.1	1	μA
Reference						
V_{REF}	Reference voltage	$T_J = 25\text{ °C}$	0.788	0.8	0.812	V
		Over temperature range	0.776	0.8	0.824	
SVR	Supply voltage rejection	$V_I = 2.5\text{ V} \pm 0.5\text{ V}$, $V_O = 1\text{ V}$, $F = 120\text{ Hz}$, $V_{BIAS} = 3.3\text{ V}$		68		dB

1. For $V_O \leq 1\text{ V}$, V_{BIAS} dropout specification does not apply due to a minimum 3 V V_{BIAS} input.

2. Fixed output voltage version only.

7 Typical characteristics

Figure 7. Reference voltage vs. temperature

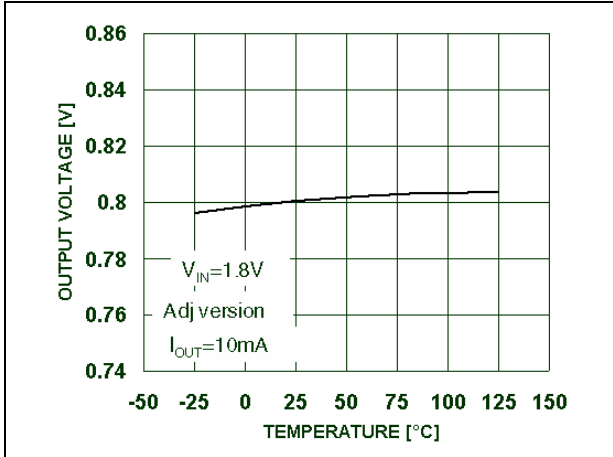

Figure 8. Output voltage vs. temperature

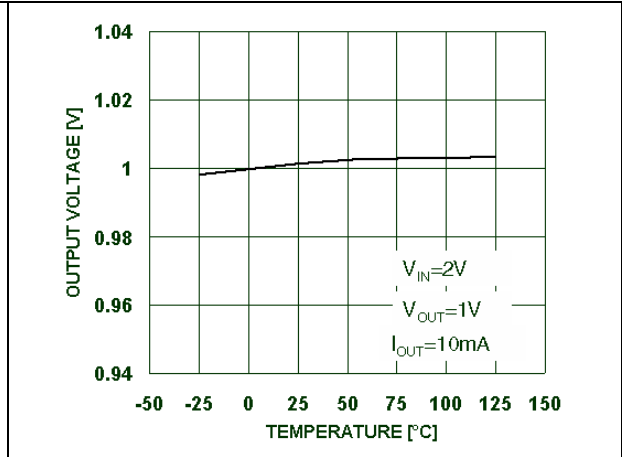

Figure 9. Load regulation vs. temperature

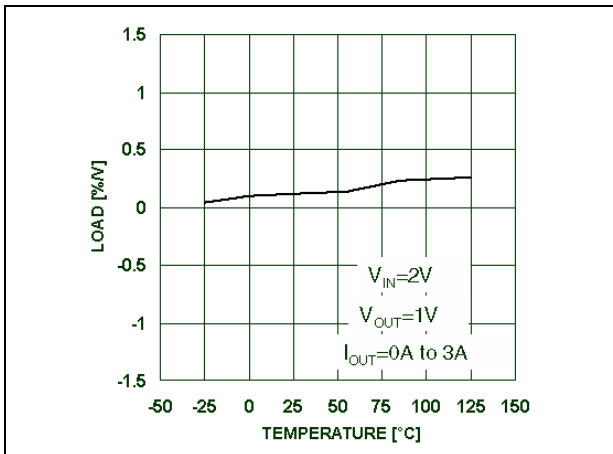

Figure 10. Line regulation vs. temperature

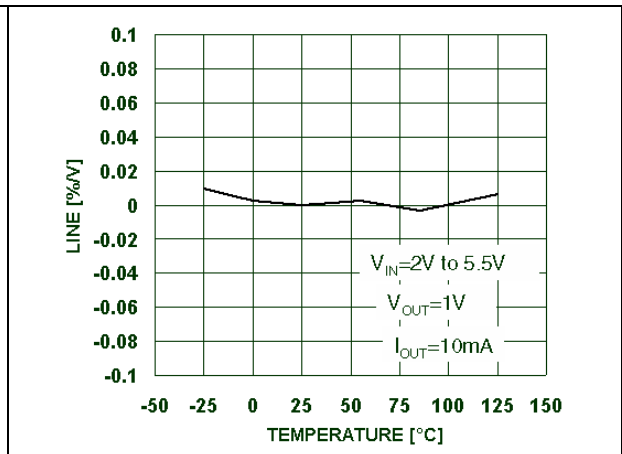

Figure 11. Output voltage vs. input voltage

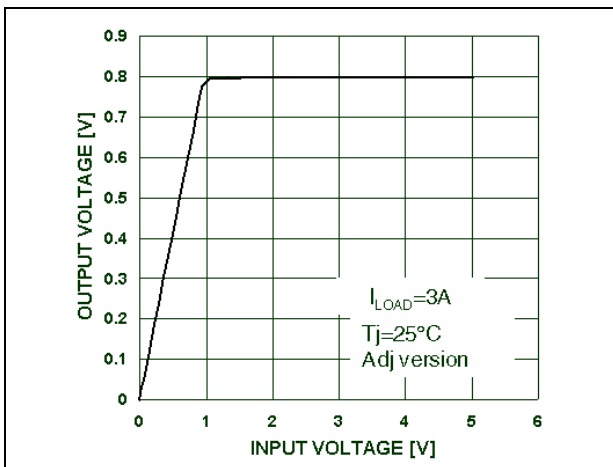

Figure 12. Dropout voltage ($V_{IN}-V_{OUT}$) vs. temperature

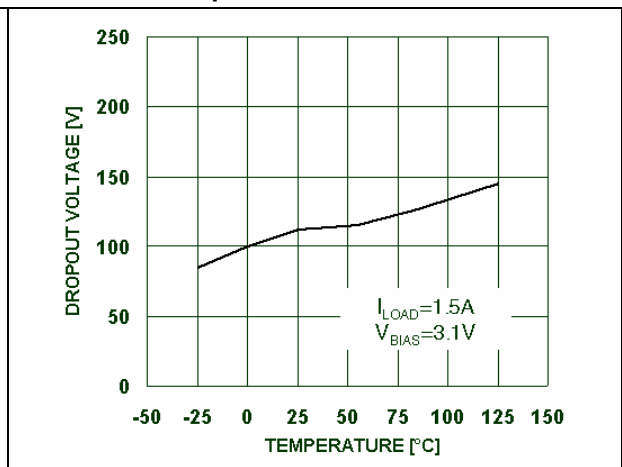

Figure 13. Dropout voltage ($V_{IN}-V_{OUT}$) vs. temperature

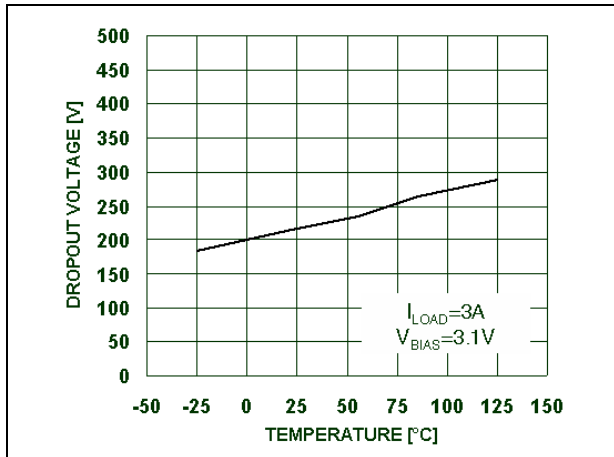

Figure 14. V_{BIAS} pin current vs. temperature

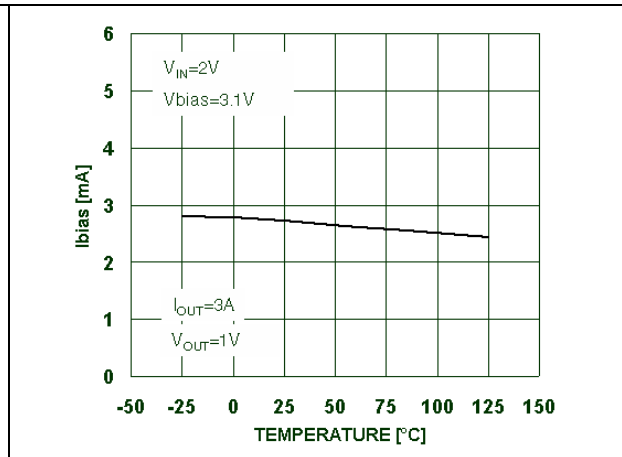

Figure 15. Noise vs. frequency

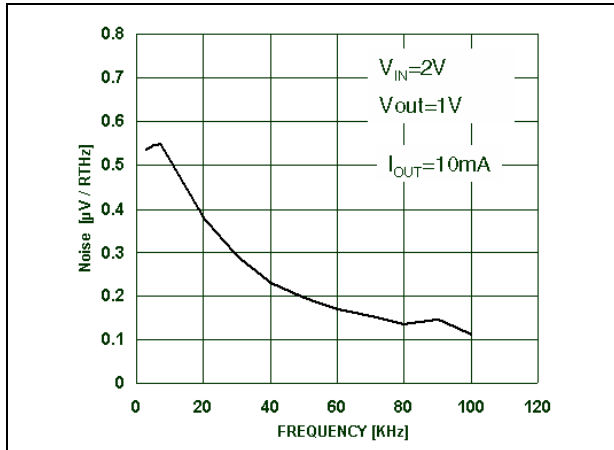

Figure 16. Quiescent current vs. temperature

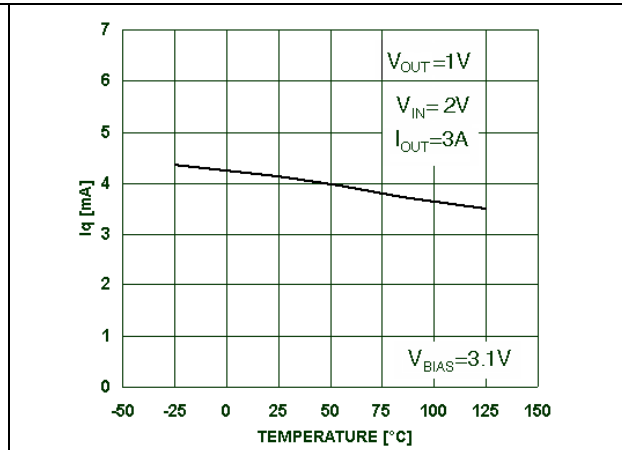

Figure 17. Supply voltage rejection vs. output current

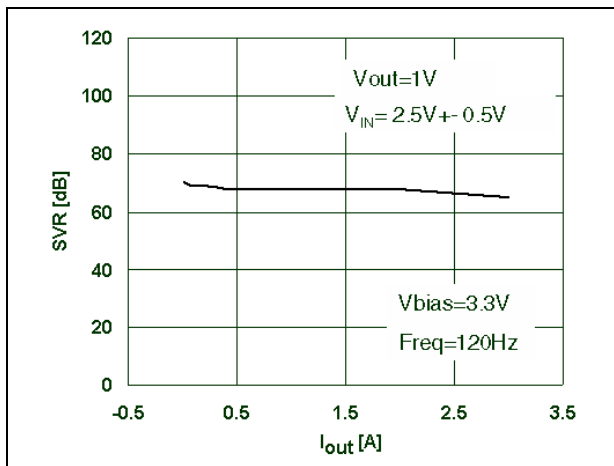

Figure 18. Stability region vs. C_{OUT} & high ESR

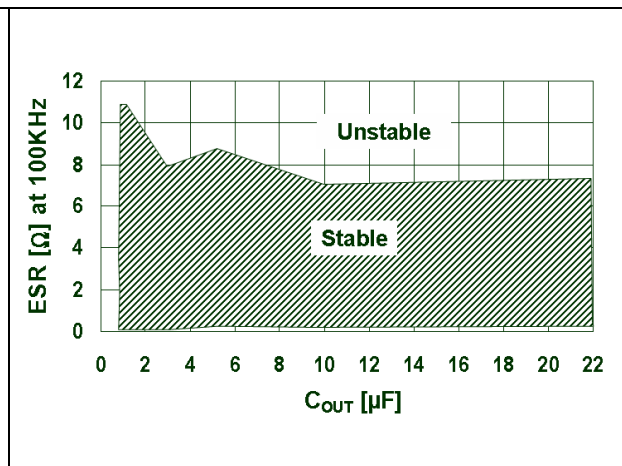

Figure 19. Stability region vs. C_{OUT} & low ESR Figure 20. V_{BIAS} & V_{IN} start up transient response (V_{IN} and V_{BIAS} start up at the same time)

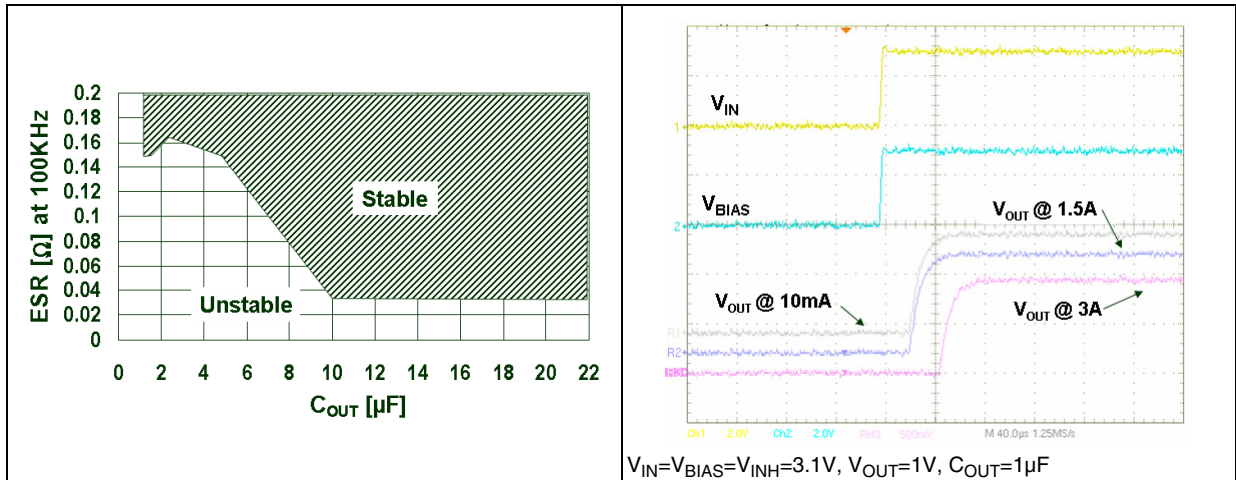

Figure 21. V_{IN} start up transient response (V_{BIAS} start up before V_{IN})

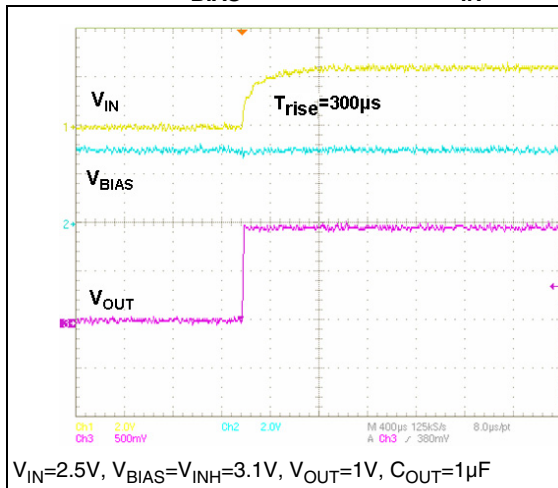

Figure 22. V_{IN} start up transient response (V_{BIAS} start up before V_{IN})

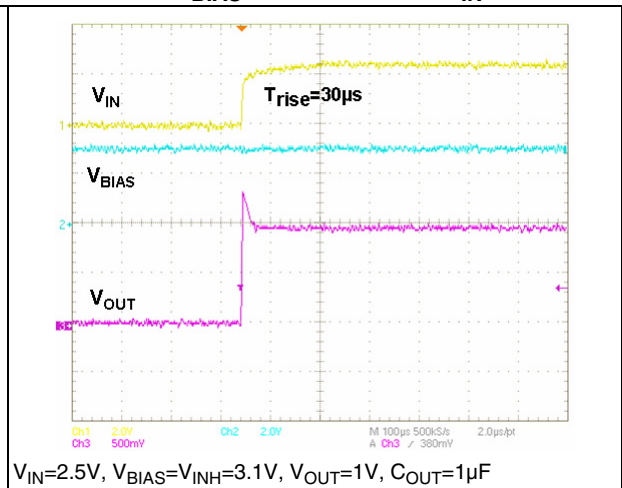

Figure 23. V_{IN} start up transient response (V_{BIAS} start up before V_{IN} and $V_{INH} = V_{IN}$)

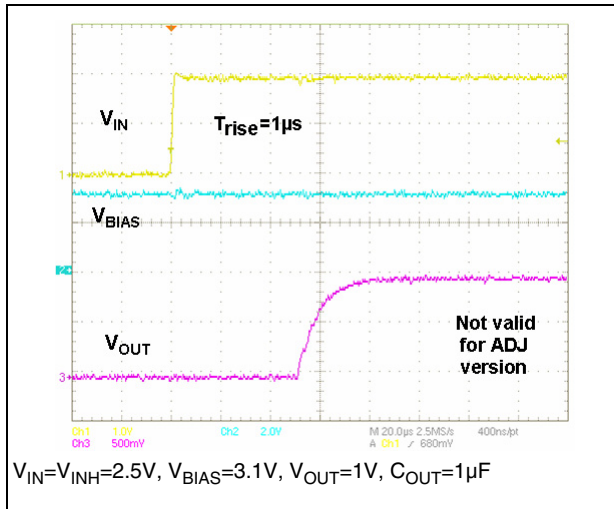
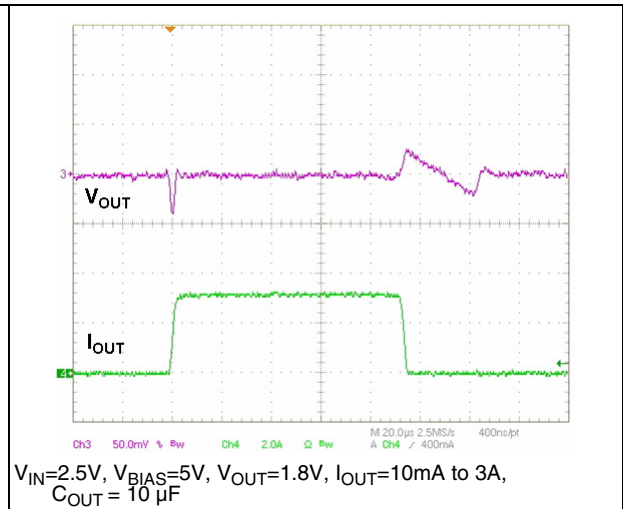

Figure 24. Load transient response



8 Application hints

The LD49300xx is an ultra-high performance, low dropout linear regulator, designed for high current application that requires fast transient response. The LD49300xx operates from two input voltages, to reduce dropout voltage. The LD49300xx is designed so that a minimum of external component are necessary.

8.1 Input supply voltage (V_{IN})

V_{IN} provides the power input current to the LD49300xx. The minimum input voltage can be as low as 1.4 V, allowing conversion from very low voltage supplies to achieve low output voltage levels with very low power dissipation.

8.2 Bias supply voltage (V_{BIAS})

The LD49300xx control circuitry is supplied the V_{BIAS} pin which requires a very low bias current (3 mA typ.) even at the maximum output current level (3 A). A bypass capacitor on the bias pin is recommended to improve the performance of the LD49300xx during line and load transient. The small ceramic capacitor from V_{BIAS} to ground reduces high frequency noise that could be injected into the control circuitry from the bias rail. In typical applications a 1 μ F ceramic chip capacitor may be used. The V_{BIAS} input voltage must be 2.1 V above the output voltage, with a minimum V_{BIAS} input voltage of 3 V.

8.3 External capacitors

To assure regulator stability, input and output capacitors are required as shown in the typical application circuit.

8.4 Output capacitor

The LD49300xx requires a minimum output capacitance to maintain stability. A ceramic chip capacitor of at least 1 μ F is required. However, specific capacitor selection could be needed to ensure the transient response. A 1 μ F ceramic chip capacitor satisfies most applications but 10 μ F is recommended to ensure better transient performances. In applications where the V_{IN} level is close to the maximum operating voltage ($V_{IN} > 4$ V), it is strongly recommended to use an output capacitors of, at least, 10 μ F in order to avoid over-voltage stress on the Input/output power pins during short circuit conditions due to parasitic inductive effect. The output capacitor must be located as close as possible to the output pin of the LD49300xx. The ESR (equivalent series resistance) of the output capacitor must be within the "STABLE" region as shown in the typical characteristics figures. Both ceramic and tantalum capacitors are suitable.

8.5 Minimum load current

The LD49300xx does not require a minimum load to maintain output voltage regulation.

8.6 Power sequencing recommendations

In order to ensure the correct biasing and settling of the regulator internal circuitry during the startup phase, as well as to avoid overvoltage spikes at the output, it is recommended to provide for the correct power sequencing.

As a general rule the V_{IN} and V_{INH} signals timings at startup should be chosen properly, so that they are applied to the device after the V_{BIAS} voltage is already settled at its minimum operative value (see paragraph [8.2: Bias supply voltage \(VBIAS\)](#)). This can be achieved, for instance, by avoiding too slow V_{BIAS} rising edges ($T_r > 10$ ms).

Provided that the above condition is satisfied, when fast V_{IN} transient input ($T_r < 100$ μ s) is present, a smooth startup, with limited overvoltage on the output, can be obtained by applying V_{IN} voltage at the same time as the V_{BIAS} voltage (refer to [Figure 20](#), [Figure 21](#) and [Figure 22 on page 11](#)).

In the fixed voltage versions it is possible to reduce overvoltage spikes during very fast startup ($T_r \ll 100$ μ s) by pulling the V_{INH} pin up to V_{IN} voltage (see [Figure 23 on page 12](#)).

8.7 Power dissipation/heatsinking

A heatsink may be required depending on the maximum power dissipation and maximum ambient temperature of the application. Under all possible conditions, the junction temperature must be within the range specified under operating conditions. The total power dissipation of the device is given by:

$$P_D = V_{IN} \times I_{IN} + V_{BIAS} \times I_{BIAS} - V_{OUT} \times I_{OUT}$$

Where:

- V_{IN} , Input supply voltage
- V_{BIAS} , Bias supply voltage
- V_{OUT} , Output voltage
- I_{OUT} , Load current

From this data, we can calculate the thermal resistance (θ_{SA}) required for the heat sink using the following formula:

$$\theta_{SA} = (T_J - T_A/P_D) - (\theta_{JC} + \theta_{CS})$$

The maximum allowed temperature rise (T_{Rmax}) depends on the maximum ambient temperature (T_{Amax}) of the application, and the maximum allowable junction temperature (T_{Jmax}):

$$T_{Rmax} = T_{Jmax} - T_{Amax}$$

The maximum allowable value for junction to ambient thermal resistance, θ_{JA} , can be calculated using the formula:

$$\theta_{JAmax} = T_{Rmax} / P_D$$

This part is available for the PPAK package.

The thermal resistance depends on the amount of copper area or heat sink, and on air flow. If the maximum allowable value of θ_{JA} calculated above is ≥ 100 $^{\circ}$ C/W for the PPAK package, no heatsink is needed since the package can dissipate enough heat to satisfy these requirements. If the value for allowable θ_{JA} falls below these limits, a heat sink is required as described below.

8.8 Heatsinking PPAK package

The PPAK package uses the copper plane on the PCB as a heatsink. The tab of these packages is soldered to the copper plane for heat sinking. It is also possible to use the PCB ground plane as a heatsink. This area can be the inner GND layer of a multi-layer PCB, or, in a dual layer PCB, it can be an unbroken GND area on the opposite side where the IC is situated with a dissipating area thermally connected through vias holes, filled by solder.

Figure 25 shows a curve for θ_{JA} of the PPAK package for different copper area sizes, using a typical PCB with 1/16 in thick G10/FR4.

Figure 25. θ_{JA} vs. Copper Area for PPAK package

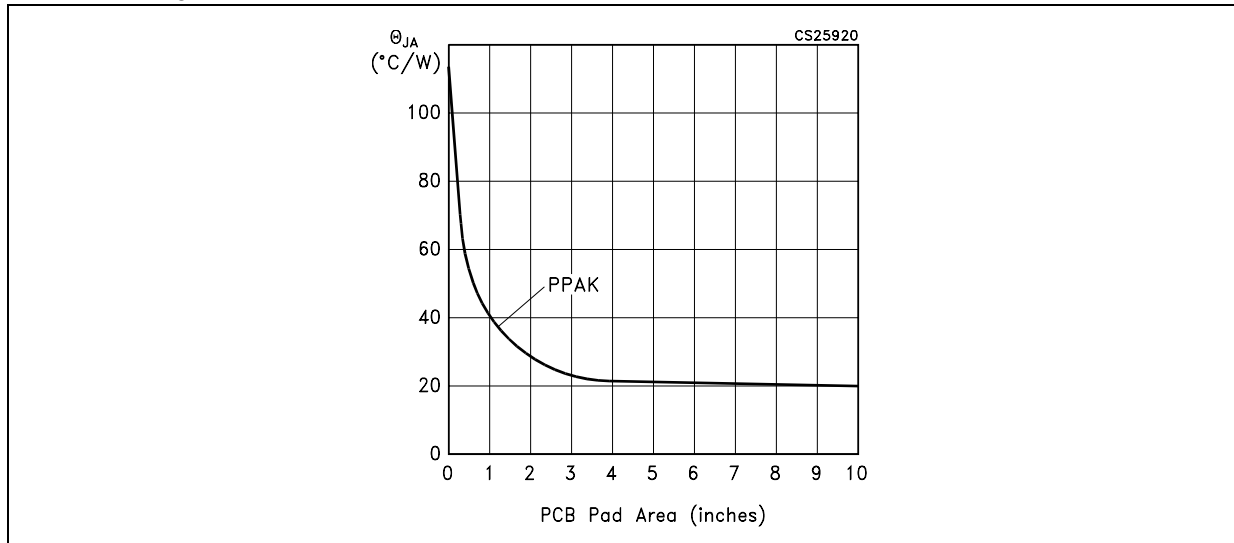

8.9 Adjustable regulator design

The LD49300xx adjustable version allows fixing output voltage anywhere between 0.8 V and 4.5 V using two resistors as shown in the typical application circuit. For example, to fix the R1 resistor value between V_{OUT} and the ADJ pin, the resistor value between ADJ and GND (R2) is calculated by:

$$R2 = R1 [0.8 / (V_{OUT} - 0.8)]$$

Where V_{OUT} is the desired output voltage.

It is suggested to use R1 values lower than 10 k Ω to obtain better load transient performances. Even, higher values up to 100 k Ω are suitable.

8.10 Enable

The fixed output voltage versions of LD49300xx feature an active high enable input (EN) that allows on-off control of the regulator. The EN input threshold is guaranteed between 0.4 V and 1.4 V, for simple logic interfacing. The regulator is set in shut down mode when $V_{EN} < 0.4$ V and it is in operating mode (V_{OUT} activated) when $V_{EN} > 1.4$ V. If not in use, the EN pin must be tied directly to the V_{IN} to keep the regulator continuously activated. The En pin must not be left at high impedance.

9 Package mechanical data

In order to meet environmental requirements, ST offers these devices in different grades of ECOPACK[®] packages, depending on their level of environmental compliance. ECOPACK[®] specifications, grade definitions and product status are available at: www.st.com. ECOPACK[®] is an ST trademark.

PPAK mechanical data

Dim.	mm.			inch.		
	Min.	Typ.	Max.	Min.	Typ.	Max.
A	2.2		2.4	0.086		0.094
A1	0.9		1.1	0.035		0.043
A2	0.03		0.23	0.001		0.009
B	0.4		0.6	0.015		0.023
B2	5.2		5.4	0.204		0.212
C	0.45		0.6	0.017		0.023
C2	0.48		0.6	0.019		0.023
D	6		6.2	0.236		0.244
D1		5.1			0.201	
E	6.4		6.6	0.252		0.260
E1		4.7			0.185	
e		1.27			0.050	
G	4.9		5.25	0.193		0.206
G1	2.38		2.7	0.093		0.106
H	9.35		10.1	0.368		0.397
L2		0.8	1		0.031	0.039
L4	0.6		1	0.023		0.039
L5	1			0.039		
L6		2.8			0.110	

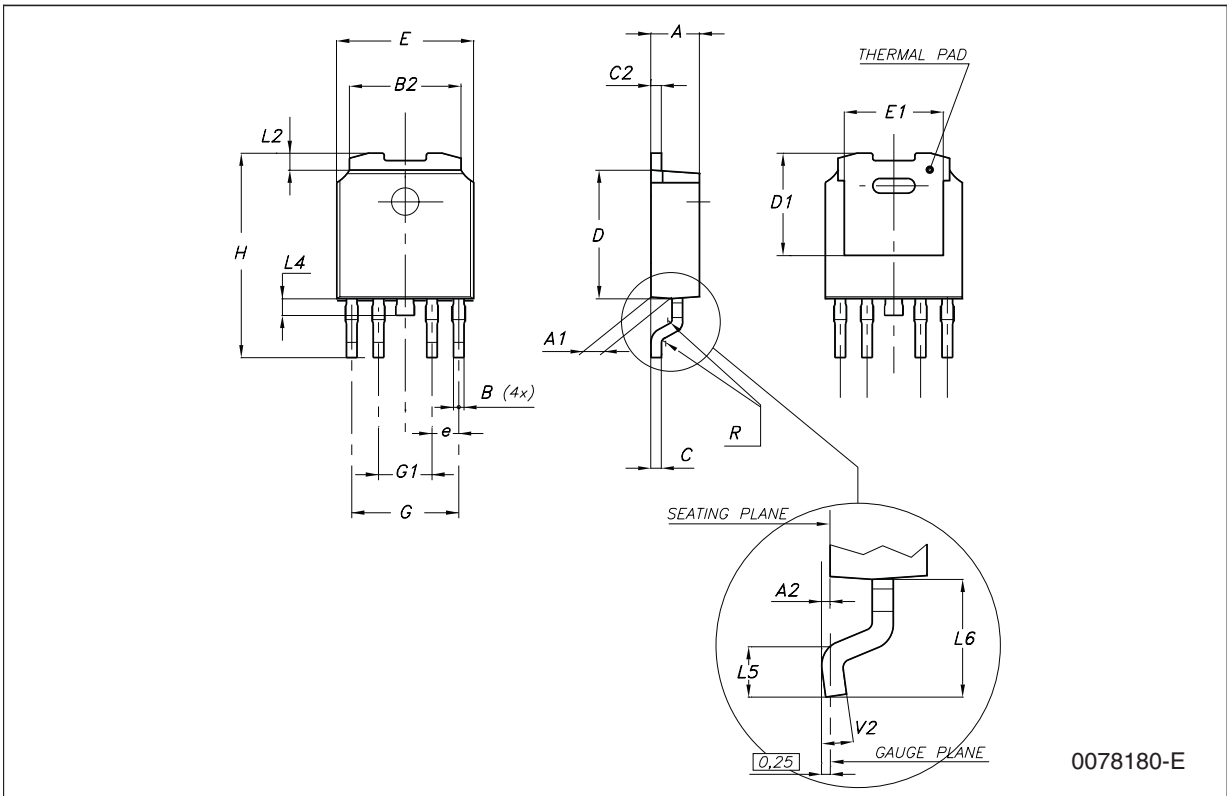

Tape & reel DPAK-PPAK mechanical data

Dim.	mm.			inch.		
	Min.	Typ.	Max.	Min.	Typ.	Max.
A			330			12.992
C	12.8	13.0	13.2	0.504	0.512	0.519
D	20.2			0.795		
N	60			2.362		
T			22.4			0.882
Ao	6.80	6.90	7.00	0.268	0.272	0.276
Bo	10.40	10.50	10.60	0.409	0.413	0.417
Ko	2.55	2.65	2.75	0.100	0.104	0.105
Po	3.9	4.0	4.1	0.153	0.157	0.161
P	7.9	8.0	8.1	0.311	0.315	0.319

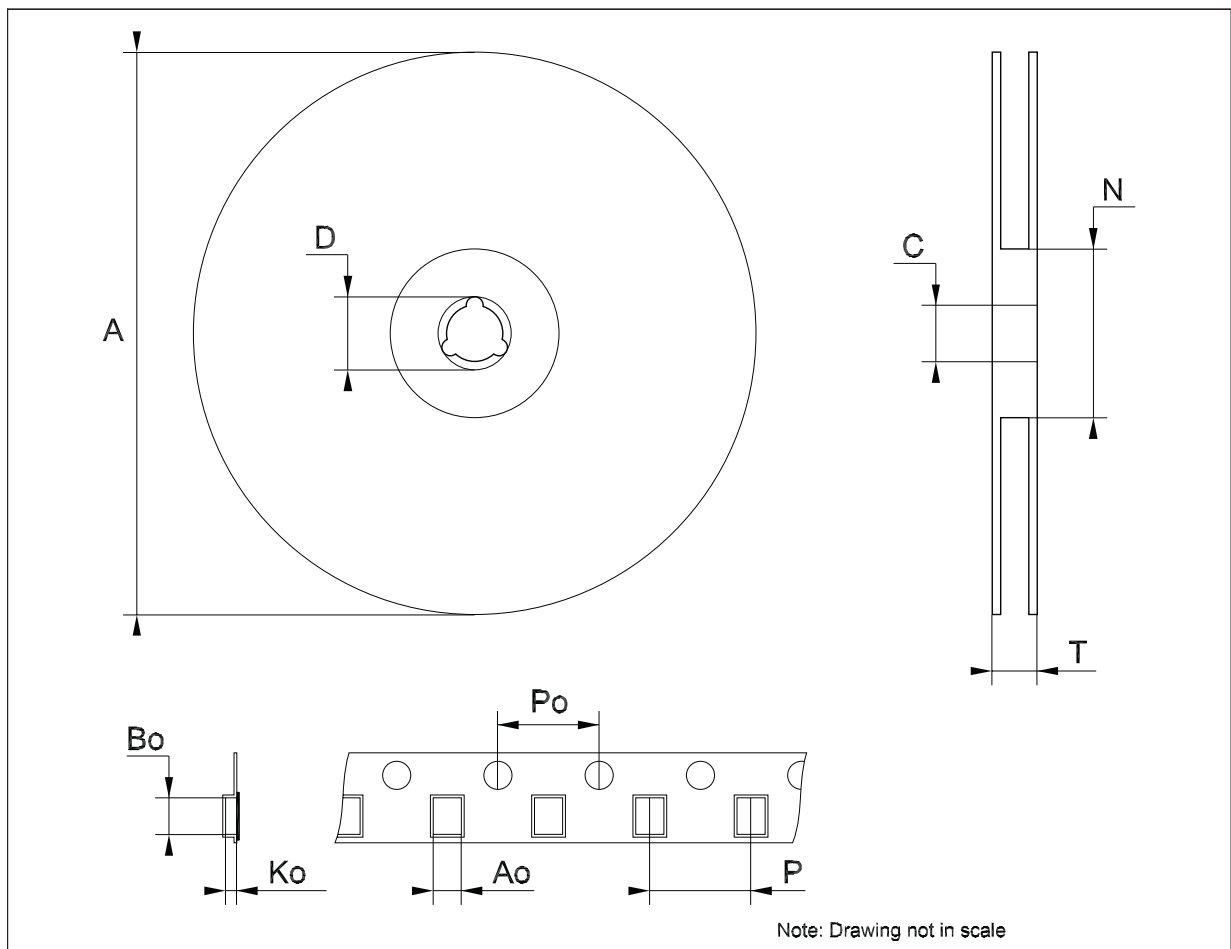

10 Revision history

Table 6. Document revision history

Date	Revision	Changes
20-Nov-2006	1	Initial release.
01-Dec-2006	2	Add note in cover page.
30-Jun-2010	3	Modified Section 8.6: Power sequencing recommendations on page 14.

Please Read Carefully:

Information in this document is provided solely in connection with ST products. STMicroelectronics NV and its subsidiaries ("ST") reserve the right to make changes, corrections, modifications or improvements, to this document, and the products and services described herein at any time, without notice.

All ST products are sold pursuant to ST's terms and conditions of sale.

Purchasers are solely responsible for the choice, selection and use of the ST products and services described herein, and ST assumes no liability whatsoever relating to the choice, selection or use of the ST products and services described herein.

No license, express or implied, by estoppel or otherwise, to any intellectual property rights is granted under this document. If any part of this document refers to any third party products or services it shall not be deemed a license grant by ST for the use of such third party products or services, or any intellectual property contained therein or considered as a warranty covering the use in any manner whatsoever of such third party products or services or any intellectual property contained therein.

UNLESS OTHERWISE SET FORTH IN ST'S TERMS AND CONDITIONS OF SALE ST DISCLAIMS ANY EXPRESS OR IMPLIED WARRANTY WITH RESPECT TO THE USE AND/OR SALE OF ST PRODUCTS INCLUDING WITHOUT LIMITATION IMPLIED WARRANTIES OF MERCHANTABILITY, FITNESS FOR A PARTICULAR PURPOSE (AND THEIR EQUIVALENTS UNDER THE LAWS OF ANY JURISDICTION), OR INFRINGEMENT OF ANY PATENT, COPYRIGHT OR OTHER INTELLECTUAL PROPERTY RIGHT.

UNLESS EXPRESSLY APPROVED IN WRITING BY AN AUTHORIZED ST REPRESENTATIVE, ST PRODUCTS ARE NOT RECOMMENDED, AUTHORIZED OR WARRANTED FOR USE IN MILITARY, AIR CRAFT, SPACE, LIFE SAVING, OR LIFE SUSTAINING APPLICATIONS, NOR IN PRODUCTS OR SYSTEMS WHERE FAILURE OR MALFUNCTION MAY RESULT IN PERSONAL INJURY, DEATH, OR SEVERE PROPERTY OR ENVIRONMENTAL DAMAGE. ST PRODUCTS WHICH ARE NOT SPECIFIED AS "AUTOMOTIVE GRADE" MAY ONLY BE USED IN AUTOMOTIVE APPLICATIONS AT USER'S OWN RISK.

Resale of ST products with provisions different from the statements and/or technical features set forth in this document shall immediately void any warranty granted by ST for the ST product or service described herein and shall not create or extend in any manner whatsoever, any liability of ST.

ST and the ST logo are trademarks or registered trademarks of ST in various countries.

Information in this document supersedes and replaces all information previously supplied.

The ST logo is a registered trademark of STMicroelectronics. All other names are the property of their respective owners.

© 2010 STMicroelectronics - All rights reserved

STMicroelectronics group of companies

Australia - Belgium - Brazil - Canada - China - Czech Republic - Finland - France - Germany - Hong Kong - India - Israel - Italy - Japan - Malaysia - Malta - Morocco - Philippines - Singapore - Spain - Sweden - Switzerland - United Kingdom - United States of America

www.st.com