



LC89091JA

CMOS LSI

Digital Audio Interface Receiver

ON Semiconductor®

<http://onsemi.com>

1. Overview

The LC89091JA is a digital audio interface receiver that demodulates signals according to the data transfer format between digital audio devices via IEC60958, IEC61937 and JEITA CPR-1205.

It supports demodulation sampling frequencies of up to 192kHz.

The LC89091JA adjusts to using in various systems including AV receivers, digital TVs and DVD recorders.

2. Features

- S/PDIF demodulation process according to IEC60958, IEC61937 and JEITA CPR-1205
- Outputs master clock: 512fs, 256fs and 128fs (with output frequency automatic adjustment function)
- Audio data output interface: 24-bit I²S and MSB first left justified
- I²C microcontroller interface (with address automatic increment function)
- Built-in power-on reset circuit
- Supply voltages: 3.0 to 3.6V
- Package: SSOP16 (lead-free and halogen-free)
- Operation guarantee temperature: -30 to 70°C

Applications

- Consumer Audio
- Digital Audio Interface

End Products

- AV Receiver
- Home Theater-in-a-Box
- Mini Compo
- Sound Bar
- Headphone Amplifier

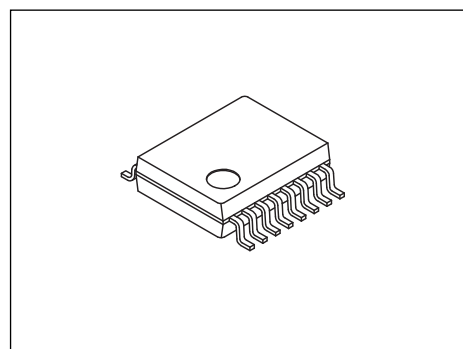

SSOP16(225mil)

* I²C Bus is a trademark of Philips Corporation.

ORDERING INFORMATION

See detailed ordering and shipping information on page 30 of this data sheet.

3. Package Dimensions

unit : mm

SSOP16 (225mil)
CASE 565AM
ISSUE A

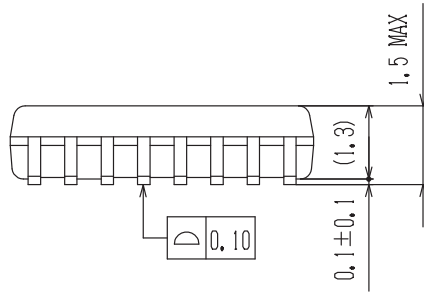
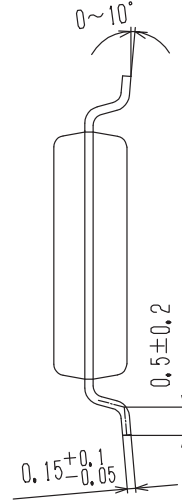
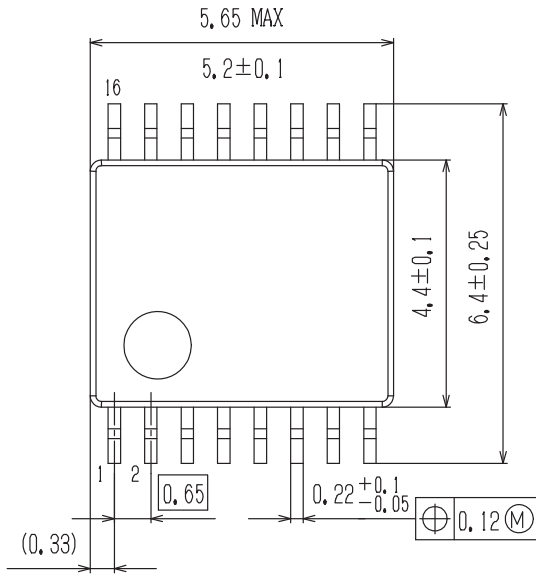

SOLDERING FOOTPRINT*

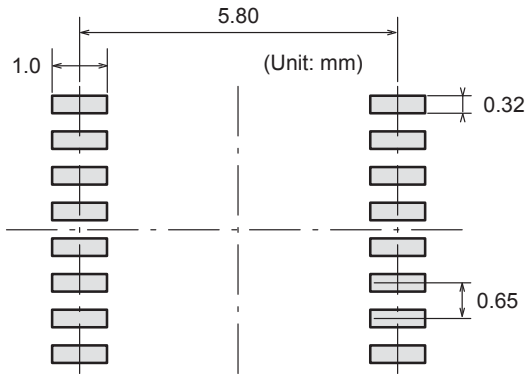

NOTE: The measurements are not to guarantee but for reference only.

*For additional information on our Pb-Free strategy and soldering details, please download the ON Semiconductor Soldering and Mounting Techniques Reference Manual, SOLDERRM/D.

GENERIC MARKING DIAGRAM*

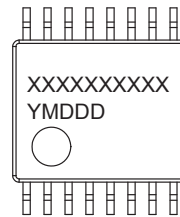

XXXXXX = Specific Device Code
Y = Year
M = Month
DDD = Additional Traceability Data

*This information is generic. Please refer to device data sheet for actual part marking. Pb-Free indicator, "G" or microdot "▪", may or may not be present.

4. Pin Assignment

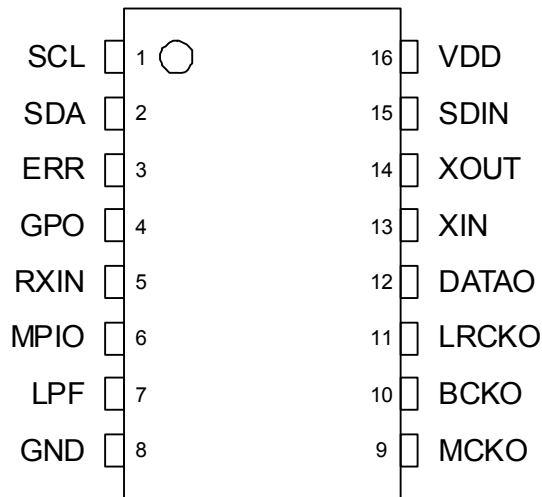

Figure 4.1: LC89091JA Pin Assignment

5. Pin Functions

Table 5.1: Pin Functions

| No | Name | I/O | Function |
|----|-------|-----|--|
| 1 | SCL | I | Microcontroller interface I ² C: clock input pin |
| 2 | SDA | I | Microcontroller interface I ² C: data input pin |
| | | O | Microcontroller interface I ² C: data output pin |
| 3 | ERR | O | PLL lock error and data error flag output pin (initial output) |
| | | | Output data mute signal output pin |
| 4 | GPO | O | Channel status bit-1 (PCM or non-PCM flag) output pin (initial output) |
| | | | Input S/PDIF (RXIN or MPIO) through output pin |
| | | | General purpose output pin |
| 5 | RXIN | I | 3.3V tolerance TTL-compatible S/PDIF input pin |
| 6 | MPIO | O | Channel status emphasis flag output pin (initial output) |
| | | I | 3.3V tolerance TTL-compatible S/PDIF input pin |
| 7 | LPF | O | PLL: Loop filter connection output pin |
| 8 | GND | | Digital GND |
| 9 | MCKO | O | Master clock output pin (512fs, 256fs, and 128fs) |
| 10 | BCKO | O | Bit clock output pin (64fs) |
| 11 | LRCKO | O | LR clock output pin (fs) |
| 12 | DATAO | O | Serial audio data output pin (I ² S and left justified) |
| 13 | XIN | I | Crystal resonator connection or external clock input pin (24.576MHz) |
| 14 | XOUT | O | Crystal resonator connection output pin |
| 15 | SDIN | I | Serial audio data input pin |
| 16 | VDD | | Digital power supply (3.3V) |

*Pin.2 and Pin 6 configure an open-drain output.

*Pin.2 needs a pull-up resistor when using microcontroller interface.

*Pin.6 needs a pull-up resistor when set to the output.

6. Block Diagram

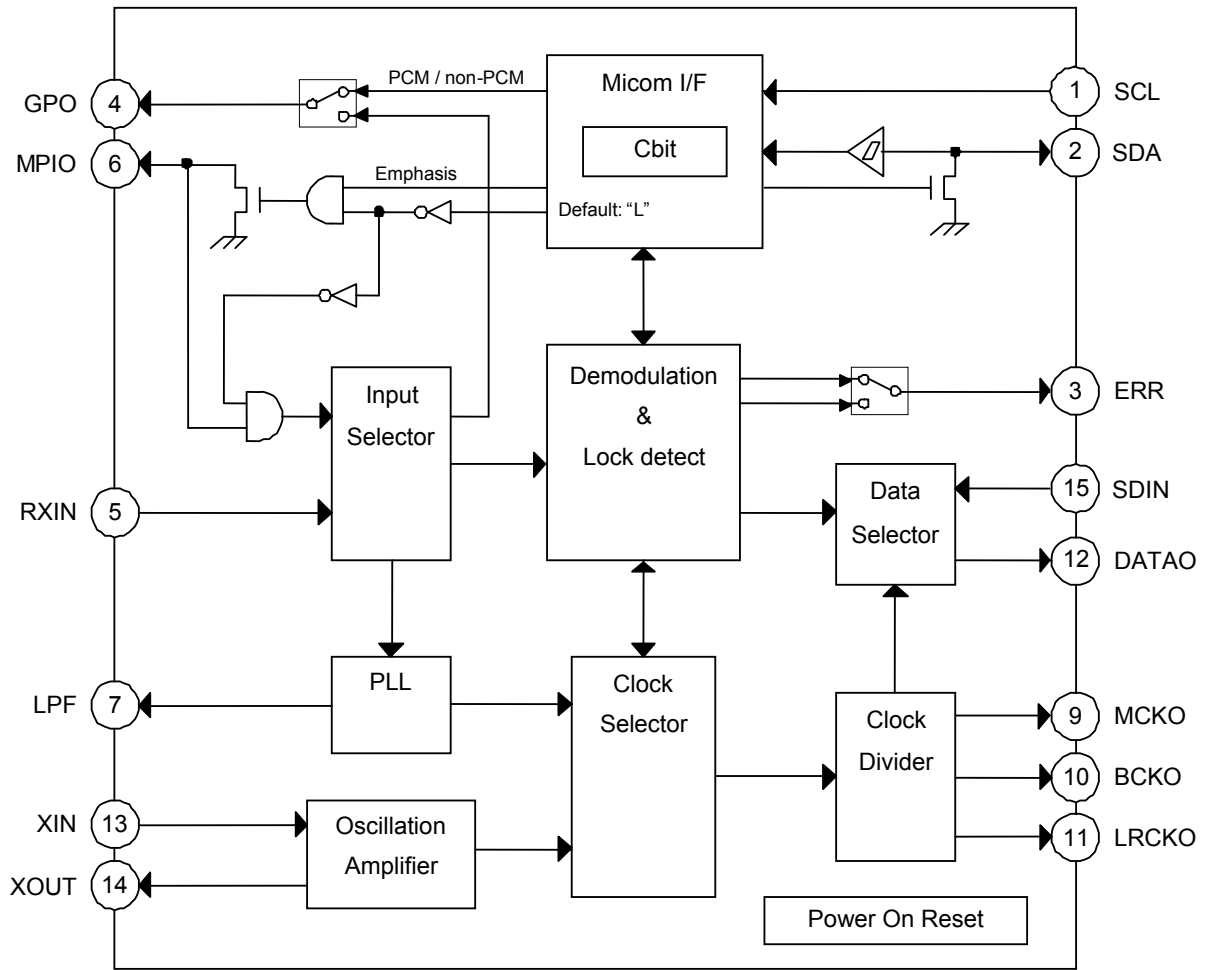

Figure 6.1: LC89091JA Block Diagram

7. Electrical Characteristics

7.1 Absolute Maximum Ratings

Table 7.1: Absolute Maximum Ratings at GND=0V

| Parameter | Symbol | Conditions | Ratings | Unit |
|-------------------------------|------------------------------------|------------|---|------|
| Maximum supply voltage | V _{DD} max | 7.1.1 | -0.3 to 4.6 | V |
| Input voltage | V _{IN} | 7.1.2 | -0.3 to V _{DD} max+0.3 (max.4.6Vp-p) | V |
| Output voltage | V _{OUT} | 7.1.3 | -0.3 to V _{DD} max+0.3 (max.4.6Vp-p) | V |
| Storage ambient temperature | T _{stg} | | -55 to 125 | °C |
| Operating ambient temperature | T _{opr} | | -30 to 70 | °C |
| Maximum input/output current | I _{IN} , I _{OUT} | 7.1.4 | ±20 | mA |

7.1.1: V_{DD} pin

7.1.2: SCL, SDA, RXIN, MPIO, XIN and SDIN pins

7.1.3: SDA, ERR, GPO, MPIO, MCKO, BCKO, LRCKO, DATAO and XOUT pins

7.1.4: Per input/output pin

Stresses exceeding those listed in the Maximum Ratings table may damage the device. If any of these limits are exceeded, device functionality should not be assumed, damage may occur and reliability may be affected.

7.2 Allowable Operating Range

Table 7.2: Recommended Operating Conditions at GND=0V

| Parameter | Symbol | Conditions | min | typ | max | Unit |
|-------------------------|------------------|------------|-----|-----|-----|------|
| Supply voltage | V _{DD} | 7.2.1 | 3.0 | 3.3 | 3.6 | V |
| Input voltage range | V _{IN} | 7.2.2 | 0 | | 3.6 | V |
| Output load capacitance | C _{L1} | 7.2.3 | | | 20 | pF |
| Output load capacitance | C _{L2} | 7.2.4 | | | 30 | pF |
| Operating temperature | V _{opr} | | -30 | 25 | 70 | °C |

7.2.1: V_{DD} pin

7.2.2: SCL, SDA, RXIN, MPIO, XIN and SDIN pins

7.2.3: MCKO pin

7.2.4: Output pins expect MCKO pin

Functional operation above the stresses listed in the Recommended Operating Ranges is not implied. Extended exposure to stresses beyond the Recommended Operating Ranges limits may affect device reliability.

7.3 DC Characteristics

Table 7.3: DC Characteristics at Ta=-30 to 70°C, V_{DD}=3.0 to 3.6V, GND=0V

| Parameter | Symbol | Conditions | min | max | Unit |
|--------------------------------|------------------|------------|----------------------|--------------------|------|
| Input, High | V _{IH} | 7-3-1 | 0.7 V _{DD} | 0.2V _{DD} | V |
| Input, Low | V _{IL} | | | | V |
| Input, High | V _{IH} | 7.3.2 | 2.0 | 0.8 | V |
| Input, Low | V _{IL} | | | | V |
| Output, High | V _{OH} | 7.3.3 | V _{DD} -0.8 | 0.4 | V |
| Output, Low | V _{OL} | | | | V |
| V _{DD} Supply Current | I _{DD1} | 7.3.4 | | 20 | mA |
| V _{DD} Supply Current | I _{DD2} | 7.3.5 | | 2 | μA |

7.3.1: CMOS-compatible: XIN pin (while external clock inputs)

7.3.2: TTL-compatible: SCL, SDA, RXIN, MPIO and SDIN pins

7.3.3: I_{OH}=-4mA, I_{OL}=4mA: ERR, MCKO, BCKO, LRCKO, DATAO and XOUT output pins

I_{OH}=-2mA, I_{OL}=2mA: SDA and MPIO output pins

7.3.4: Input fs: 96kHz, MCKO: 512fs output status

7.3.5: "PDMODE=1"

7.4 AC Characteristics

Table 7.4: AC Characteristics at Ta=-30 to 70°C, VDD=3.0 to 3.6V, GND=0V

| Parameter | Symbol | min | typ | max | Unit |
|---------------------------------------|---------------|-----|--------|-----|------|
| VDD rise slope | t_{VDD} | - | - | 100 | ms |
| RXIN and MPIO input receive frequency | f_{RFS} | 28 | - | 195 | kHz |
| RXIN and MPIO input duty factor | f_{RXDUY} | 40 | 50 | 60 | % |
| XIN clock input frequency | f_{XF} | - | 24.576 | - | MHz |
| MCKO clock output frequency | f_{MCK} | 4 | - | 50 | MHz |
| MCKO clock output duty factor | $f_{XMCKDUY}$ | 40 | - | 60 | % |
| MCKO-BCKO output delay | t_{MBO} | -10 | - | 10 | ns |
| BCKO-LRCKO output delay | t_{BLO} | -10 | - | 10 | ns |
| BCKO-DATAO output delay | t_{BDO} | -10 | - | 10 | ns |
| LRCKO-DATAO output delay | t_{LDO} | -10 | - | 10 | ns |

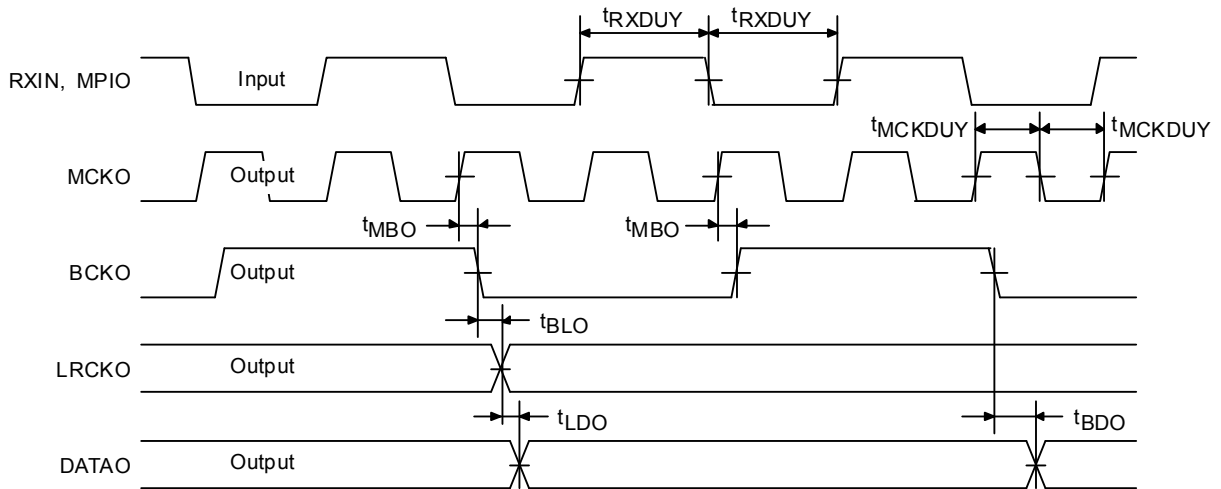

Figure 7.1: AC Characteristics

7.5 I²C Microcontroller Interface AC Characteristics

Table 7.5: AC Characteristics at Ta=-30 to 70°C, V_{DD}=3.0 to 3.6V, GND=0V

| Parameter | Symbol | min | max | Unit |
|----------------------------|------------------------|----------|-----|------|
| RSTB input pulse width (L) | t _{RSTdw} | - | 400 | kHz |
| SCL input frequency | f _{SCL} | 600 | - | ns |
| SCL input pulse width (L) | t _{SCLdw} | 1300 | - | ns |
| SCL input pulse width (H) | t _{SCLuw} | 600 | - | ns |
| Start (repeated) setup | t _{CSBuw} | 600 | - | ns |
| SDA hold | t _{SDAhold} | 0 | 900 | ns |
| SDA setup | t _{SDAsetup} | 100 | - | ns |
| SCL-SDA rise time | t _{SCLSDArd} | 20+0.1Cb | 300 | ns |
| SCL-SDA fall time | t _{SCLSDAfd} | 20+0.1Cb | 300 | ns |
| Stop setup | t _{STOPsetup} | 600 | - | ns |
| Bus open | t _{BUSopen} | 1300 | - | ns |
| Spike pulse width | t _{SPKpw} | 0 | 50 | ns |

C_b = total capacitance of one bus line in pF.

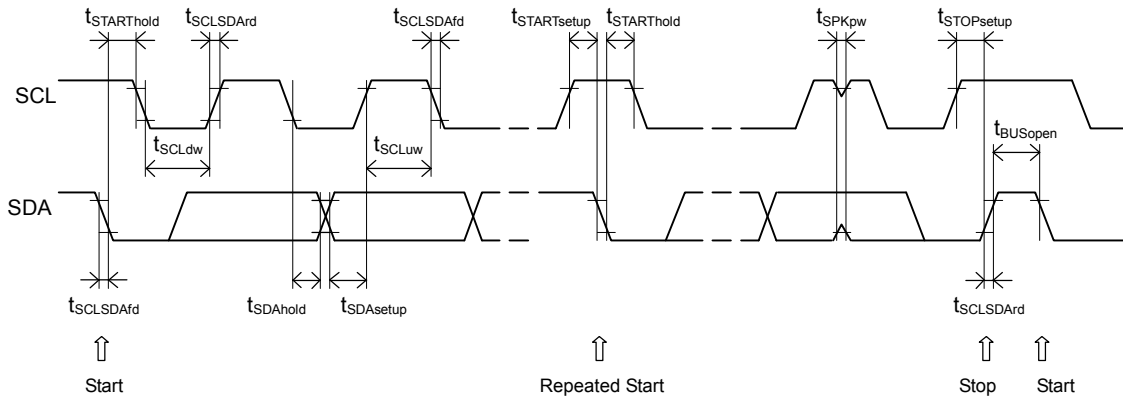

Figure 7.2: I²C Microcontroller Interface AC Characteristics

Product parametric performance is indicated in the Electrical Characteristics for the listed test conditions, unless otherwise noted. Product performance may not be indicated by the Electrical Characteristics if operated under different conditions.

8. System Settings

8.1 Power-On Reset

- The LC89091JA features a built-in power-on reset circuit, and constantly monitors the power supply status.

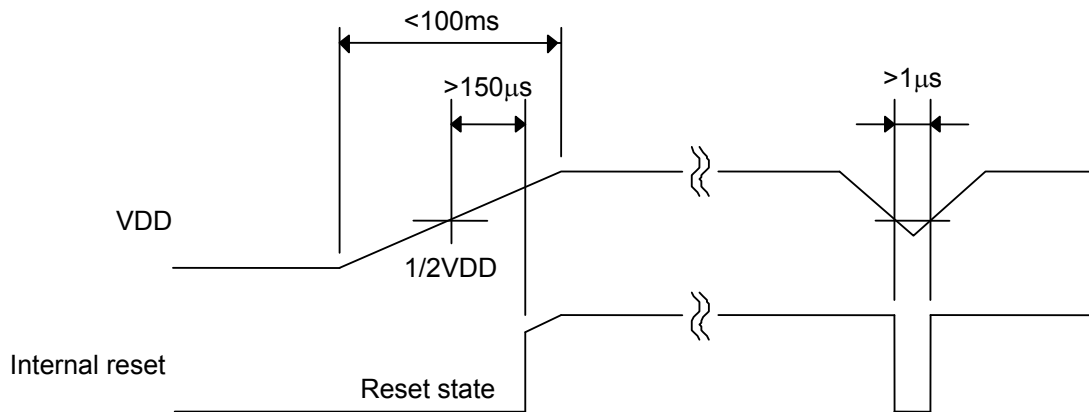

Figure 8.1: Power-On Reset Timing

Table 8.1: Output Port State Immediately after Power-On Reset

| Pin No. | Port Name | Output State | Pin No. | Port Name | Output State |
|---------|-----------|------------------------------------|---------|-----------|-------------------------------------|
| 3 | ERR | H output | 10 | BCKO | XIN/4 input clock output (6.144MHz) |
| 4 | GPO | L output (Non-PCM flag) | 11 | LRCKO | XIN/256 input clock output (96kHz) |
| 6 | MPIO | Hi-Z output (Emphasis flag) | 12 | DATAO | SDIN input data output |
| 9 | MCKO | XIN input clock output (24.576MHz) | 14 | XOUT | XIN invert output |

8.2 Register Reset and Power-Down Mode

- The SYSRST register resets circuits other than register.
- During reset period, register setting state hold and can also change.
- Although a system is reset by SYSRST register, the oscillation amplifier operates, and the clock is output to MCKO, BCKO and LRCKO pins. But, DATAO pin outputs "L" without relation to the setup.
- The system is set power-down mode by PDMODE register.
- During power-down mode period, register setting state hold and can also change.
- In power-down mode, the circuits expect a power-on reset and a microcontroller interface will be set to stop condition all the circuit operations, and the clock is not output.

8.3 Oscillation Amplifier Pin Settings (XIN, XOUT)

- The LC89091JA has a built-in oscillation amplifier, and connects a quartz resonator, feedback resistor and load capacitance to XIN and XOUT to configure an oscillation circuit. The figure below shows the connection diagram.
- When connecting a quartz resonator, use one with a fundamental wave, and be aware that the load capacitance depends on the quartz resonator characteristics, so thorough investigation should be made.
- If the built-in oscillation amplifier is not used and an oscillation module is used as the clock source instead, connect the output of an external clock supply source to XIN. At this time, it is not necessary to connect a feedback resistor between XIN and XOUT.
- Always supply 24.576MHz clock to XIN.
- XIN clock is output to MCKO, BCKO and LRCKO while PLL is locked.

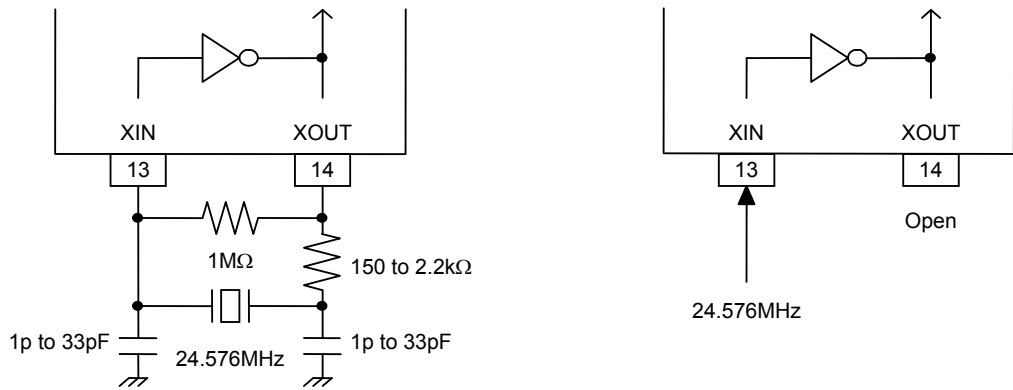

(a) XIN and XOUT Quartz Resonator Connection Diagram (b) XIN External Clock Input Diagram

Figure 8.2: XIN and XOUT External Circuit Connection Diagram

8.4 Loop Filter Pin Setting (LPF)

- The LC89091JA has a built-in VCO (Voltage Controlled Oscillator) that synchronizes with sampling frequencies from 32kHz to 192kHz and with the data with a transfer rate from 4MHz to 25MHz.
- The PLL is locked at 512fs.
- LPF is a pin for the PLL loop filter. Connect the resistor and capacitors shown in the right figure, as close to the pin as possible.

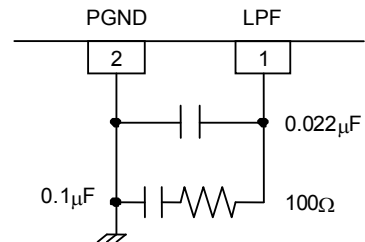

Figure 8.3: LPF External Circuit Connection Diagram

8.5 Clocks

8.5.1 Master Clock

- The clock source is selected between the following two master clocks.
 - 1) PLL source: 512fs
 - 2) XIN source: 24.576MHz

8.5.2 PLL Source Master Clock

- The PLL synchronizes with the input S/PDIF and outputs 512fs clock.
- The PLL clock is controlled by PLLACC, PLLDIV[1:0] and PRSEL[1:0] register settings.
- Normally, "PLLACC=0" is set and PLL clock is output for each input sampling frequency band. At this setting, output clock frequency fluctuation by varying the sampling frequency is kept to a narrow band, such as 512fs output when fs=32kHz to 48kHz, 256fs output when fs=64kHz to 96kHz, and 128fs output when fs=128kHz to 192kHz.
- When "PLLACC=0" is set, the PLL clock is set with the PLLDIV[1:0] register
- When "PLLACC=0" is set, during the PLL is locked, switching is not performed even when the PLLDIV[1:0] register setting is changed. These registers switching are executed when the PLL is in unlocked status. This setting becomes valid after the PLL is locked again.
- To set an output clock that does not depend on the S/PDIF input sampling frequency, "PLLACC=1" is set. At this setting, the clock frequency is always multiplied by a constant and output, such as output at 256fs for all sampling frequencies from 32kHz to 192kHz.
- When "PLLACC=1" is set, the PLL clock is set with the PRSEL[1:0] register.
- When "PLLACC=1" is set, PRSEL[1:0] register can be changed even PLL lock state.
- The change to "PLLACC=1" from "PLLACC=0" is possible even PLL lock state. But, the setting change to "PLLACC=0" from "PLLACC=1" becomes valid after the PLL is locked again.
- The PLL output clock setting flow is shown below.

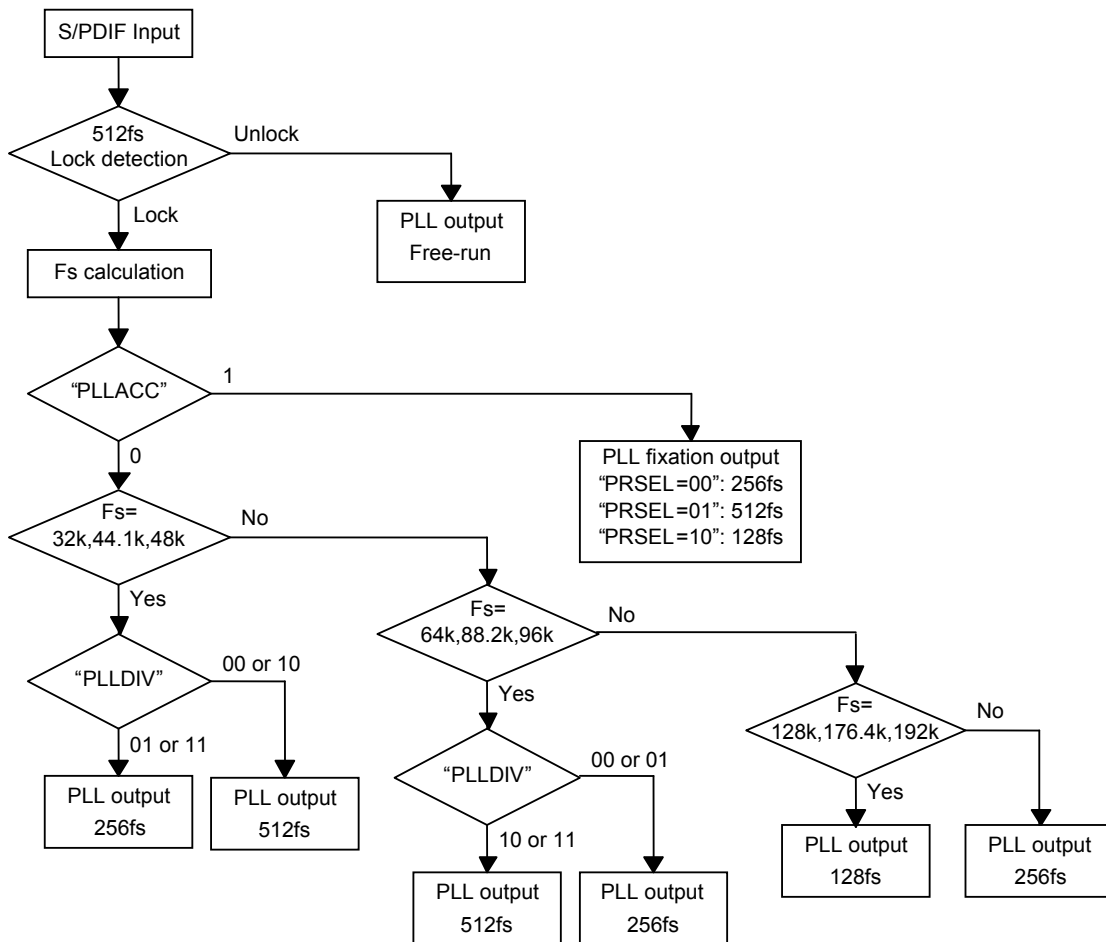

Figure 8.4: PLL Output Clock Flow Diagram

- The PLL clock output frequencies are shown below.
- When "PLLACC=1" and "PRSEL[1:0]=01" (512fs) are set, 128kHz, 176.4kHz and 192kHz S/PDIF reception results in a PLL output frequency that exceeds 50MHz, so direct output to MCKO is not guaranteed.

Table 8.2: PLL Clock Output Frequencies (Bold settings are initial values.)

| S/PDIF fs (kHz) | PLL clock output frequencies (MHz) | | | | | | |
|-----------------------|---|-------------|-------------|-------------|--|-----------------------|-----------------------|
| | "PLLACC=0" (Fixed multiple outputs for each input fs band) | | | | "PLLACC=1" (Fixed multiple outputs of input fs) | | |
| | "PLLDIV=00" | "PLLDIV=01" | "PLLDIV=10" | "PLLDIV=11" | "PRSEL=00" (256fs) | "PRSEL=01" (512fs) | "PRSEL=10" (128fs) |
| 32 | 16.38 | 8.19 | 16.38 | 8.19 | 8.19 | 16.38 | 4.09 |
| 44.1 | 22.57 | 11.28 | 22.57 | 11.28 | 11.28 | 22.57 | 5.64 |
| 48 | 24.57 | 12.28 | 24.57 | 12.28 | 12.28 | 24.57 | 6.14 |
| 64 | 16.38 | 16.38 | 32.76 | 32.76 | 16.38 | 32.76 | 8.19 |
| 88.2 | 22.57 | 22.57 | 45.15 | 45.15 | 22.57 | 45.15 | 11.28 |
| 96 | 24.57 | 24.57 | 49.15 | 49.15 | 24.57 | 49.15 | 12.28 |
| 128 | 16.38 | 16.38 | 16.38 | 16.38 | 32.76 | 65.54 * | 16.38 |
| 176.4 | 22.57 | 22.57 | 22.57 | 22.57 | 45.15 | 90.32 * | 22.57 |
| 192 | 24.57 | 24.57 | 24.57 | 24.57 | 49.15 | 98.30 * | 24.57 |

*: Direct output to the MCKO pin is not guaranteed.

8.5.3 XIN Source Master Clock (XIN, XOUT)

- Supply XIN with clocks all the time to be used in the following applications.
 - 1) Clock source when the PLL is unlocked
 - 2) PLL lock-in support
 - 3) Calculation of the S/PDIF input data sampling frequency
- 24.576MHz clock always has to supply to XIN.
- Normally, the oscillation amplifier automatically stops while the PLL is locked, but operation that always operates regardless of the PLL status can also be set. This is set with the AMPOPR register.
The AMPOPR register must be set before S/PDIF input, or the setting must be completed while the PLL is unlocked.
- For fixing a system clock to a XIN clock, PLL is changed into an unlocking state. The ADMODE register always sets PLL as an unlocking state.
- The output clock frequency at the time of XIN source is set up with the XOUTCK register.

Table 8.3: List of Output Clock Frequencies

| Output Pin Name | When PLL is unlocked, XIN source clock (XIN input clock) | When PLL is locked, PLL source clock (Internal VCO clock) |
|----------------------|---|--|
| | | 24.576 MHz |
| Master clock MCKO | 24.576 MHz | 512fs 256fs 128fs |
| Bit clock BCKO | 6.144 MHz 3.072 MHz | 64fs |
| L/R clock LRCKO | 96 kHz 48 kHz | fs |

8.5.4 Output clock switching (MCKO, BCKO, LRCKO)

- The clock source of PLL clock or XIN clock is switched automatically according to the PLL locked or unlocked status.
- The output clock switches 2.7ms after the change of PLL status.

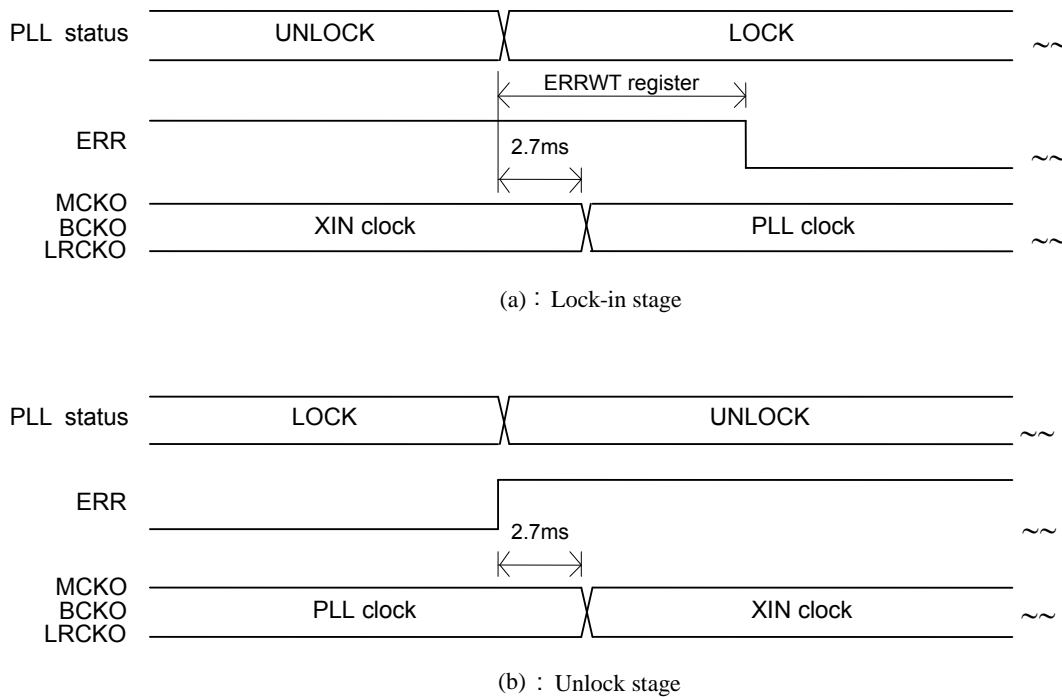

Figure 8.5: Timing Chart of Output Clock Switching

8.5.5 Calculation of digital input data sampling frequency

- The input data sampling frequency is calculated using the XIN clock.
- In the "AMPOPR=0" mode (initial value) where the oscillation amplifier automatically stops according to the lock status of the PLL, the input data sampling frequency is calculated during the ERR error period and completed when the oscillation amplifier stops with holding the value. Therefore, the value remains unchanged until the PLL becomes unlocked.
- If the oscillation amplifier is in a continuous operation mode ("AMPOPR=1"), calculation is repeated constantly. Even if sampling changes within the PLL capture range for input data whose channel status sampling information does not change, the calculation results that follow the input data can be read.
- The calculation results can be readout with the microcontroller interface.

8.6 Data

8.6.1 Reception range of S/PDIF input

- The input data reception range is 32kHz to 192kHz.

8.6.2 S/PDIF Input/Output pins (RXIN, MPIO, GPO)

- Two digital input pins and one through output pin are provided.
- RXIN and MPIO are TTL input level pins with 3.3V-tolerance voltage.
- MPSEL register needs to be set up, using MPIO as S/PDIF input.
- The demodulation data is selected with DINSEL register.
- All the S/PDIF input pins can receive 32kHz to 192kHz data.
- GPO is input selector output pin, and output the S/PDIF through data.
- The demodulated data and the through output data can be selected separately.
- The GPO pin output data is selected with GPOSEL[1:0] and THRSEL register.
- When MPIO is no-load at an output setup, don't choose MPIO by DINSEL or THRSEL register.
- In order to stop demodulation processing and to switch to oscillation amplifier operation, the S/PDIF input to RXIN and MPIO is stopped, or PLL is always set as an unlocking state by ADMODE register.

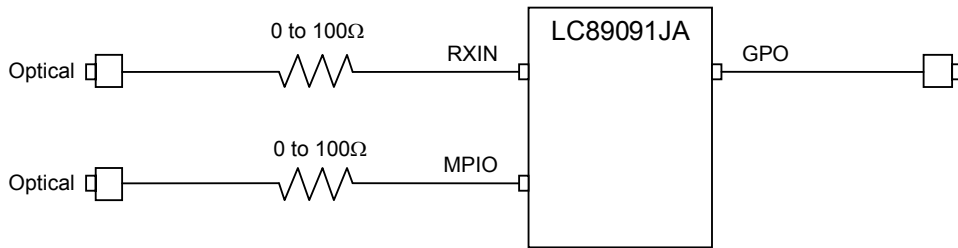
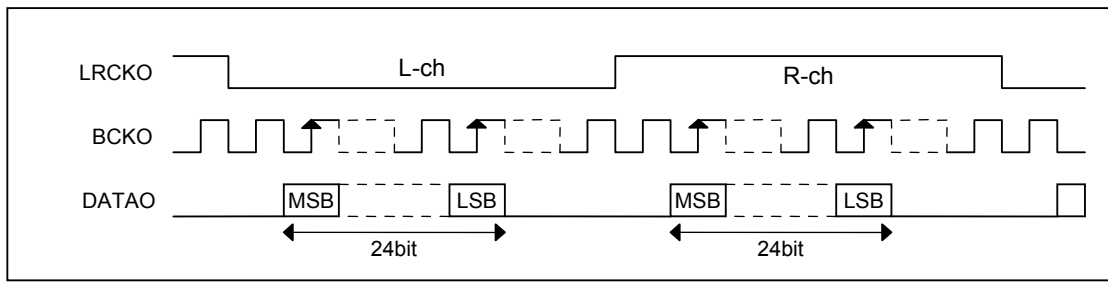

Figure 8.6: S/PDIF Input Circuit Example

8.6.3 Output Data Format (DATAO)

- The DATAO output data format is set with DAFORM register.
- The initial value of the output format is I²S. The data is output synchronized with BCKIN falling edge.



[DAFORM=0] : I²S Data Output

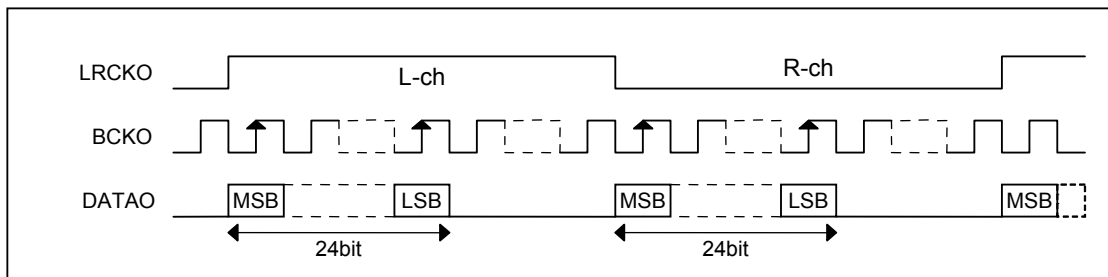

[DAFORM=1] : MSB first Left-Justified Data Output

Figure 8.7: DATAO pin Data Output Timing

8.6.4 Serial audio data input format (SDIN)

- The LC89091JA is provided with a serial data input pin of SDIN.
- The format of the serial audio data input to SDIN and the demodulation data output format must be identical.
- The SDIN data to be input must be synchronization with the BCKO and LRCKO clocks.
- The data input from the SDIN pin is through-output to the DATAO pin. Data format conversion cannot be performed.
- Normally, SDIN input data is output to DATAO pin when PLL is unlocked. But, with the ADMODE register setting, the SDIN input data is output to DATAO regardless of the locked/unlocked status of the PLL.
- The SDIN pin must be connected to GND when it is not used.

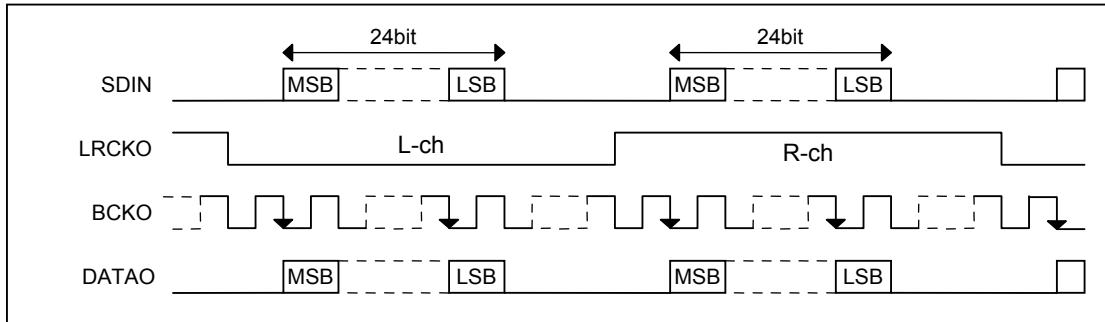

[DAFORM=0] : I²S Data Input

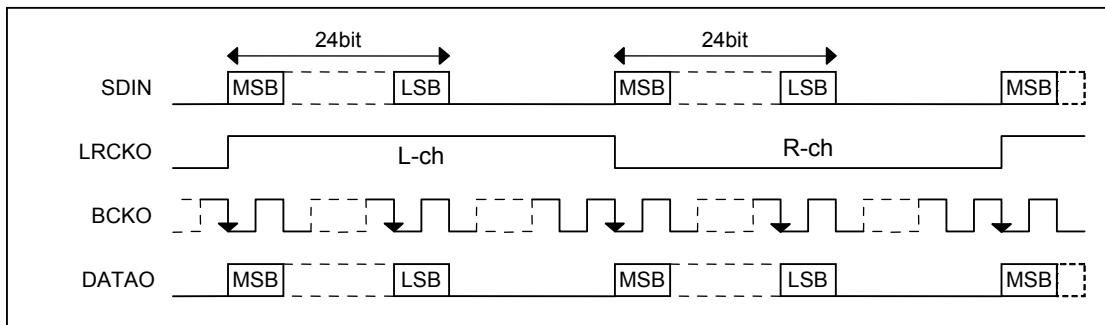

[DAFORM=1] : MSB first Left-Justified Data Input

Figure 8.8: SDIN pin Data Input Timing

8.6.5 Output data switching (SDIN, DATAO)

- DATAO outputs demodulation data when the PLL is locked, and outputs SDIN input data when the PLL is unlocked. This output is automatically switched according to the PLL locked/unlocked status.
- When SDIN input data is selected, SDIN input data must synchronize with clock source.
- DATAO output switches via a mute period.
- It adjusts by ERRWT register during the mute period at the time of PLL lock-in process.
- It adjusts by DATWT register during the mute period at the time of PLL unlock process
- With the DATMUT setting, the DATAO output data can be also muted forcibly.
- NPMODE register can be muted the DATAO output data, when non-PCM data is received. Non-PCM data applies to the state of the channel status bit 1.

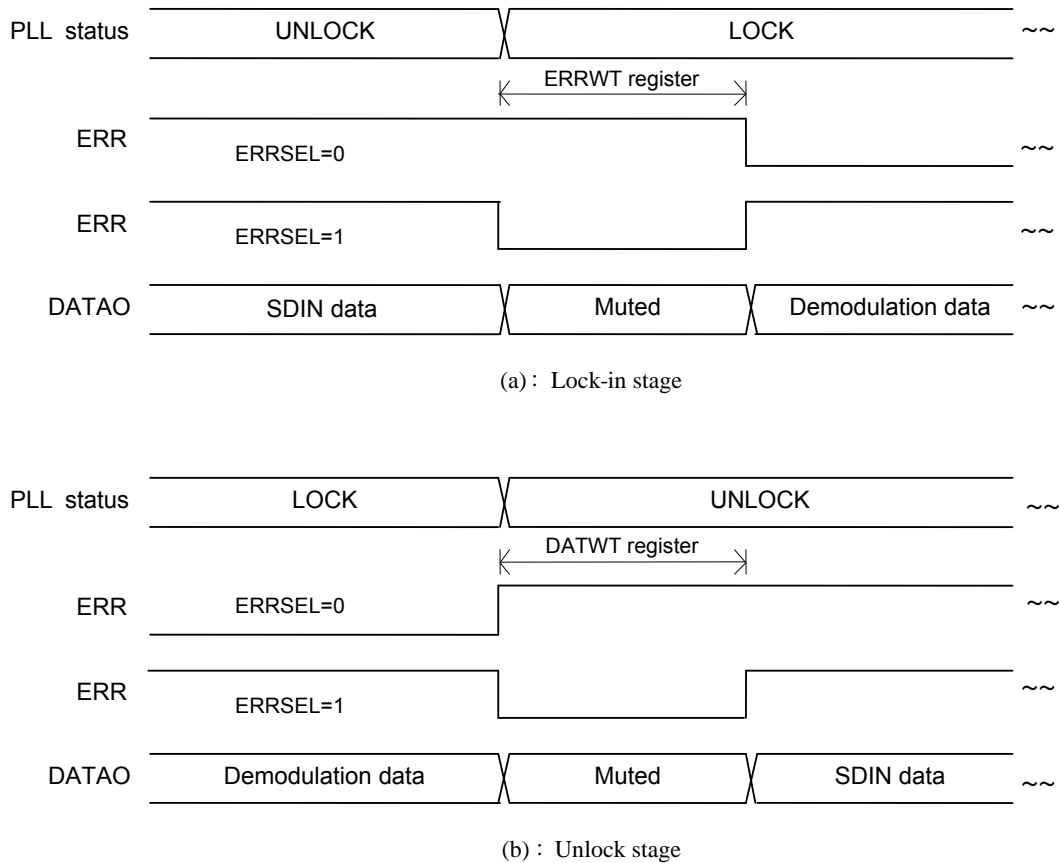

Figure 8.9: Timing Chart of DATAO Output Data Switching

8.7 Error Output Processing (ERR)

- The ERR output can be selected the following outputs by the ERRSEL register.

8.7.1 Lock Error and Data Error Output ("ERRSEL=0")

- The ERR pin outputs an error flag when PLL lock error or data error occurs.
- The ERR is output synchronizing with LRCKO and can be readout with the microcontroller interface.

8.7.1.1 PLL Lock Error

- The PLL gets unlocked for input data that lost bi-phase modulation regularity, or input data for which preambles B, M and W cannot be detected.
- However, even if preambles B, M and W are detected if the timing does not conform to the IEC60958, the PLL get unlocked and processed. For example, period of preamble B is not every 192 frames.
- The ERR outputs "H" when the PLL lock error occurs.
- The ERR outputs "L" when the data demodulation returns normal and "H" is held for somewhere between 3m to 36ms.
- This holding time is set with the ERRWT register.

Table 8.4: ERR Release Maintenance Period after a PLL Locks

| S/PDIF input sampling frequency (kHz) | ERR release maintenance period after a PLL locks (ms) | |
|---------------------------------------|---|-----------|
| | "ERRWT=0" | "ERRWT=1" |
| 32 | 18 | 36 |
| 44.1 | 13 | 26 |
| 48 | 12 | 24 |
| 88.2 | 6.5 | 13 |
| 96 | 6 | 12 |
| 176.4 | 3.3 | 6.5 |
| 192 | 3 | 6 |

8.7.1.2 Input Data Parity Error

- An odd number of errors among parity bits in input data and input parity errors are detected.
- The ERR outputs "H" when an input parity error occurs.
- When an input parity error occurs, output data is replaced to the data of one frame ago.
However, when having received non-PCM data, data does not replace. In this case, data including an error is output.

8.7.1.3 Other Errors

- Even if ERR turns to "L", the channel status bits of 24 to 27 (sampling frequency information) are always fetched and the data of the previous block is compared with the current data. Moreover, the input data sampling frequency is calculated from the fs clock extracted from the input data, and the fs calculated value is compared in the same way as described above. If any difference is detected in these data, ERR is instantly made "H" and the same processing as for PLL lock errors is carried out. In this case, the clock source is switched to XIN and processing is restarted at lock status identification processing.
- In order to support sources with a variable fs (for example, a CD player with a variable pitch function), any change in fs made after ERR is reset is not reflected on ERR unless such change exceeds the PLL capture range.

8.7.2 DATAO data Mute Signal Output ("ERRSEL=1")

- This mode outputs the state of the audio data outputted from the DATAO pin. (See "Figure 8.9")
- A mute processing setup at the time of non-PCM audio data reception ("NPMODE=1") is also reflected.

Table 8.5: DATAO Output State Signal Output

| ERR output | DATAO output conditions |
|------------|-------------------------|
| L | Muted |
| H | Outputted |

8.8 General Purpose Output (GPO)

- The GPO output can be selected the following outputs by the GPOSEL[1:0] register.

8.8.1 Channel Status Bit 1 Output ("GPOSEL[1:0]=00")

- The initial mode outputs bit 1 of the channel status that indicates whether the input bi-phase data is PCM audio data. It is immediately output upon detection of ERR even during an error output period.

Table 8.6: Channel Status Bit 1 Output

| GPO output | GPO output conditions |
|------------|--|
| L | Audio sample word represents linear PCM samples (Bit1=L) |
| H | Audio sample word used for other purposes (Bit 1=H) |

8.8.2 S/PDIF Through-output ("GPOSEL[1:0]=01")

- The data selected by the S/PDIF input selector (DINSEL register) is output. The output data is selected with the THRSEL register.

Table 8.7: Output of S/PDIF data

| GPO output | GPO output conditions |
|-------------------------|-----------------------|
| RXIN or MPIO input data | "GPOSEL[1:0]=01" |

8.8.3 Microcontroller Register Output ("GPOSEL[1:0]=10 or 11")

- This mode outputs a serial data that is set by the microcontroller interface. It can be used as a control signal of peripheral circuitry.

Table 8.8: Microcontroller Register Output

| GPO output | GPO output conditions |
|------------|-----------------------|
| L | "GPOSEL[1:0]=10" |
| H | "GPOSEL[1:0]=11" |

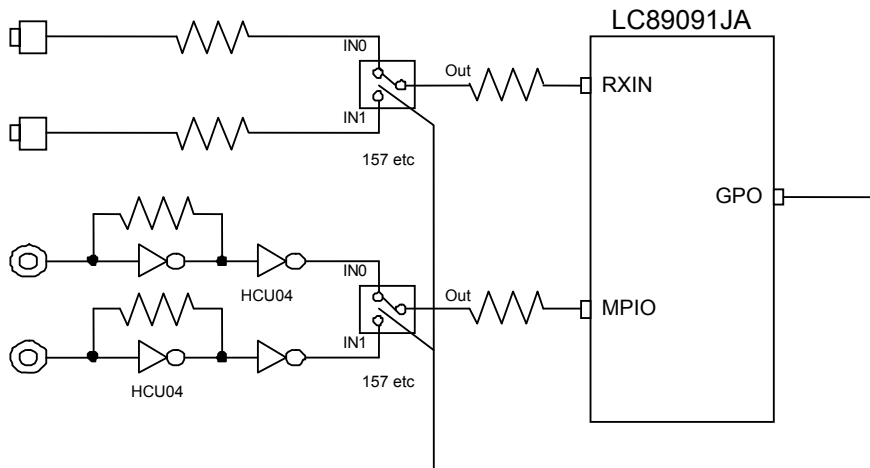

Figure 8.10: GPOSEL [1:0] register Example of Use

8.9 Multi Purpose Input/Output (MPIO)

- MPIO can be selected the following input/output by the MPSEL register.
- MPIO needs a pull-up resistor when set to the output.
- When not using MPIO, it uses no connecting (open state).
However, don't choose MPIO by DINSEL or THRSEL register.

8.9.1 Pre-emphasis Flag Output ("MPSEL=0")

- The initial mode outputs pre-emphasis of the channel status that indicates whether there is 50/15μs emphasis parameter for consumer.
- MPIO becomes a Hi-Z output when an emphasis signal is not detected. For this reason, it connects with a pull-up resistor. The example of use is shown below

Table 8.9: Pre-emphasis Flag Output

| MPIO output | MPIO output conditions |
|-------------|------------------------|
| Hi-Z (H**) | No pre-emphasis |
| L | 50/15μs pre-emphasis |

** : When MPIO connects with a pull-up resistor

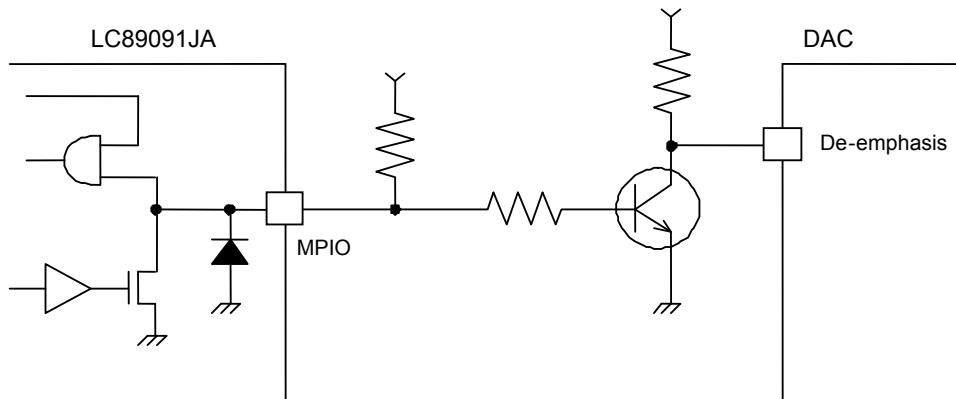

Figure 8.11: MPIO Output Example of Use (Pre-emphasis Output)

8.9.1 S/PDIF data Input ("MPSEL=1")

- MPIO can be used as S/PDIF input terminal by "MPSEL=1".
- MPIO immediately after power-on is set as an output state. For this reason, before input all the S/PDIF signals, MPIO is set as an input state by MPSEL register. If S/PDIF signal input (RXIN input) before MPSEL register setup and pre-emphasis flag is detected, MPIO output will short-circuit with peripheral circuitry. Therefore, before S/PDIF signal input, MPIO setup must be complete.

9. Microcontroller Interface

- The LC89091JA is controlled via I²C (Fast-mode, 400kHz).

9.1 Terminal Setup (SCL, SDA)

- The pull-up resistor is connected to SCL and SDA pins.
The resistor should take current and timing into consideration enough.
- If the clock line will not be Hi-Z state, the pull-up resistor of SCL may delete.
- When not using microcontroller, SCL and SDA make GND connection. In this case, initial value of register is set up.

9.2 Data Transfer

- I²C slave transceiver interface is based on ver2.1 (HS mode un-corresponding).
- At first, input Start condition and Slave-address, an acknowledge generates, WRITE operation and READ operation (input Register-address and Control-data) is executed. After the command execution, input Stop condition.
- SDA line state must be constant while SCL is "H". State change on SDA line is restricted while SCL line is "L". If SDA data changes while SCL line is "H", it will be recognized as Start condition or Stop condition.

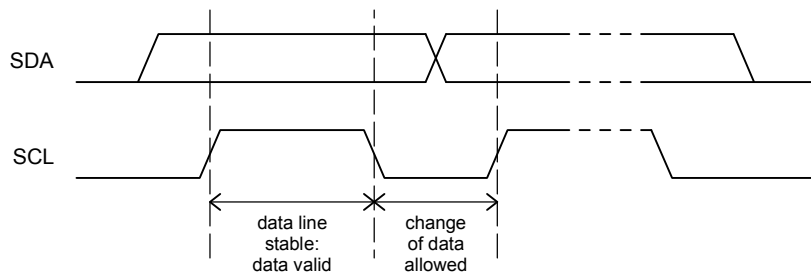

Figure 9.1: Data transfer on I²C bus

9.3 Start and Stop Condition

- The Start condition is generated by the transition of "H" to "L" on SDA line while SCL line is "H".
- The Stop condition is generated by the transition of "L" to "H" on SDA line while SCL line is "H".

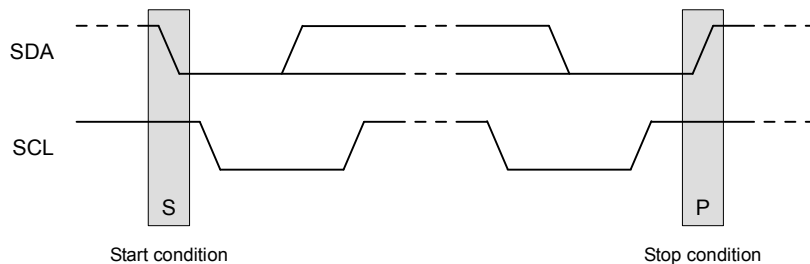

Figure 9.2: Start and Stop Condition

9.4 Acknowledge

- After receiving bits (1 byte) of data, SDA line is released, LC89091JA will stabilize SDA line in "L" state. This operation is called "acknowledgement".
- The LC89091JA generates an acknowledgement upon receipt of Start condition and Slave-address. Furthermore, for a WRITE instruction, an acknowledgement is generated whenever receipt of each byte is completed. For a READ instruction, succeeded by generation of an acknowledgement, the LC89091JA releases the SDA line after outputting data at the designated address, and it monitors the SDA line condition. When the microcontroller generates an acknowledgement without sending Stop condition, the LC89091JA outputs data at the next address location. When no acknowledgement is generated, the LC89091JA ends data output (not acknowledged).

9.5 Slave-address

- The Slave-address inputs after the Start condition.
- The Slave-address is configured with the upper 7-bits. Data of the upper 5-bits is Device code that is input "00100". The next 2-bits are Device address that is input "10".
- When the R/W bit is "1", the READ instruction is executed, and when it is "0", the WRITE instruction is executed.

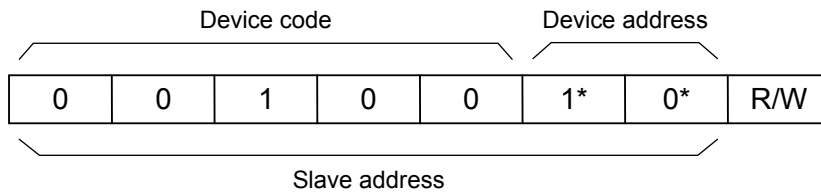

Figure 9.3: Slave-address Configuration

9.6 Register-address

- After transmitting 1 byte of data containing Slave-address, Register-address is set up from next byte.

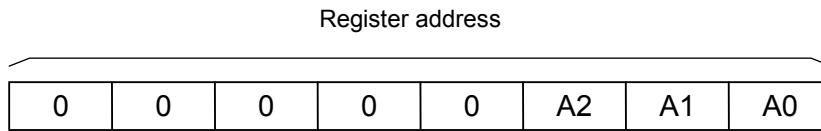

Figure 9.4: Register-address Configuration

9.7 Control Data

- The control data inputs after Register-address transmission.
- The control data (D7 to D0) is configured with MSB first.

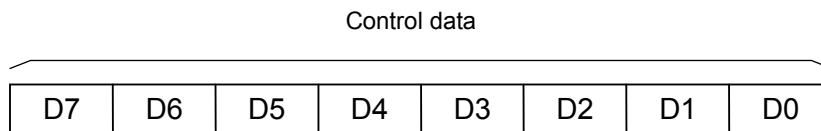

Figure 9.5: Control Data Configuration

9.8 WRITE Operation

- When the R/W bit is "0", the WRITE instruction is executed.
- After Start condition input, Slave-address (R/W=0) and Register-address are input one by one.
- After an acknowledge is generated, the write data is taken in by SCL↑ in front of an acknowledge clock pulse.
- When the Slave-address is differ, an acknowledge is not generated, SDA line will be in an open state.

In this case, it has to input from Start conditions (S).

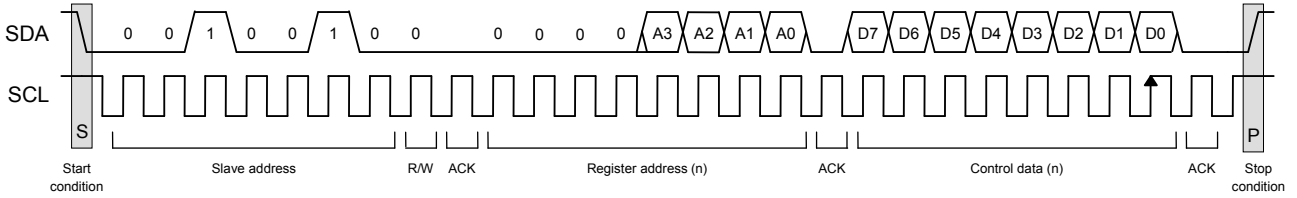

Figure 9.6: I²C Data Write Timing Chart (Byte Write)

- After receipt of 8 bits (1 byte) data, when data (1 byte) transmits further without sending Stop conditions after an acknowledge generation, the Register-address counter is incremented by one and data is stored in the next address.
- If an address value becomes 08h address, address counter will "rolls over" to 00h address and data is stored from 00h and the previous data will be overwritten.

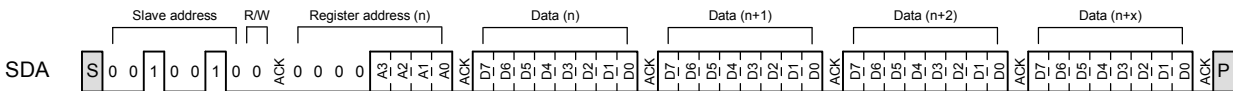

Figure 9.7: I²C Data Write Timing Chart (Page Write)

9.9 READ Operation

- When the R/W bit is "1", the READ instruction is executed.
- After Start condition input, Slave-address (R/W=0) and Register-address are input one by one.
- After an acknowledge is generated, Start condition (Sr) and Slave-address (R/W=1) input again. And, after an acknowledge is generated, the data of the Register-address specified is output.
- If the microcontroller does not generate an acknowledge but generate the Stop condition, the LC89091JA discontinues transmission.

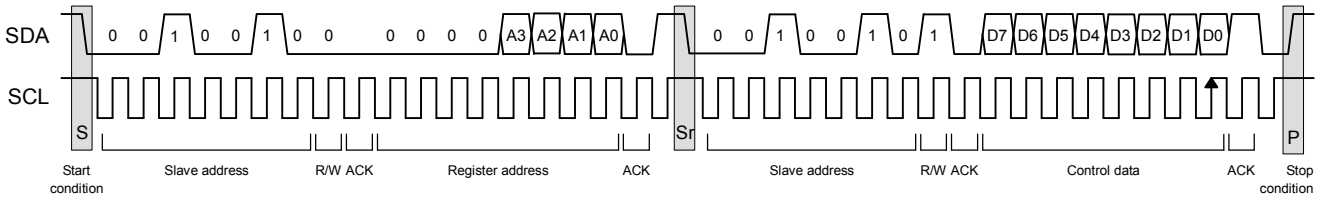

Figure 9.8: I²C Data Read Timing Chart (Random Read)

- If a microcontroller returns an acknowledge after 8 bits (1 byte) data output, the data (1 byte) of the next address will be read continuously.
- If an address value becomes 08h address, the next address will be read from 00h data one by one.
- If a microcontroller does not generate an acknowledge but generate the Stop condition, the LC89091JA discontinues transmission.

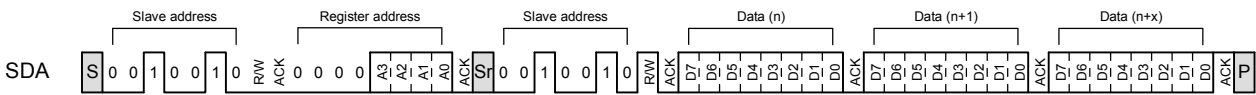

Figure 9.9: I²C Data Read Timing Chart (Sequential Read)

9.10 Registers

9.10.1 Register Map

Table 9.1: Register Map

| Setting Item | R/W | Adr | D7 | D6 | D5 | D4 | D3 | D2 | D1 | D0 |
|----------------|-----|-----|--------|--------|---------|---------|--------|---------|---------|--------|
| System | R/W | 00h | "0" | MPSEL | DATWT | ERRWT | ADMODE | AMPOPR | PDMODE | SYSRST |
| Clock | R/W | 01h | "0" | "0" | XOUTCK | PRSEL1 | PRSEL0 | PLLDIV1 | PLLDIV0 | PLLACC |
| Data | R/W | 02h | NPMODE | ERRSEL | GPOSEL1 | GPOSEL0 | DATMUT | THRSEL | DINSEL | DAFORM |
| Fs calculation | R | 03h | 0 | 0 | 0 | ERRFLG | FSC3 | FSC2 | FSC1 | FSC0 |
| Channel status | R | 04h | CS7 | CS6 | CS5 | CS4 | CS3 | CS2 | CS1 | CS0 |
| | R | 05h | CS15 | CS14 | CS13 | CS12 | CS11 | CS10 | CS9 | CS8 |
| | R | 06h | CS23 | CS22 | CS21 | CS20 | CS19 | CS18 | CS17 | CS16 |
| | R | 07h | CS31 | CS30 | CS29 | CS28 | CS27 | CS26 | CS25 | CS24 |
| | R | 08h | CS39 | CS38 | CS37 | CS36 | CS35 | CS34 | CS33 | CS32 |

- "0" is a reserved bit. Always must be set to "0".

9.10.2 Details of Registers

Address: 00h; System Setting

| 00h | D7 | D6 | D5 | D4 | D3 | D2 | D1 | D0 |
|---------------|-----|-------|-------|-------|--------|--------|--------|--------|
| Register name | "0" | MPSEL | DATWT | ERRWT | ADMODE | AMPOPR | PDMODE | SYSRST |
| Initial value | 0 | 0 | 0 | 0 | 0 | 0 | 0 | 0 |
| Setting | R | R/W | R/W | R/W | R/W | R/W | R/W | R/W |

- SYSRST** System reset
 0: Don't reset (initial value)
 1: Reset all circuits other than registers
- PDMODE** Power down mode setting
 0: Normal operation (initial value)
 1: Power down mode (clock operation stop)
- AMPOPR** Oscillation amplifier operation setting
 0: Automatic stopping of oscillation amplifier while PLL is locked (initial value)
 1: Permanent continuous operation
- ADMODE** S/PDIF reception refusal mode setting
 0: Normal operation (initial value)
 1: Always PLL unlock state
- ERRWT** ERR wait time setting after PLL is locked
 0: Error is canceled after 3 occurrences of preamble B are counted (initial value)
 1: Error is canceled after 6 occurrences of preamble B are counted
- DATWT** DATAO wait time setting after PLL is unlocked
 0: Mute is canceled after about 5.4 ms (initial value)
 1: Mute is canceled after about 342ms
- MPSEL** MPIO pin input/output setting
 0: Pre-emphasis flag output (initial value)
 1: S/PDIF input

LC89091JA

Address: 01h; Clock Setting

| 01h | D7 | D6 | D5 | D4 | D3 | D2 | D1 | D0 |
|---------------|-----|-----|--------|--------|--------|---------|---------|--------|
| Register name | "0" | "0" | XOUTCK | PRSEL1 | PRSEL0 | PLLDIV1 | PLLDIV0 | PLLACC |
| Initial value | 0 | 0 | 0 | 0 | 0 | 0 | 0 | 0 |
| Setting | R | R | R/W | R/W | R/W | R/W | R/W | R/W |

- PLLACC** PLL clock lock frequency setting
- 0: Automatic control (initial value)
 - 1: Manual setting
- PLLDIV[1:0]** PLL lock time MCKO output setting when PLLACC is set to "0"
- 00: 512fs output: When receiving 32kHz, 44.1kHz, 48kHz (initial value)
 256fs output: When receiving 64kHz, 88.2kHz, 96kHz
 128fs output: When receiving 128kHz, 176.4kHz, 192kHz
 - 01: 256fs output: When receiving 32kHz, 44.1kHz, 48kHz
 256fs output: When receiving 64kHz, 88.2kHz, 96kHz
 128fs output: When receiving 128kHz, 176.4kHz, 192kHz
 - 10: 512fs output: When receiving 32kHz, 44.1kHz, 48kHz
 512fs output: When receiving 64kHz, 88.2kHz, 96kHz
 128fs output: When receiving 128kHz, 176.4kHz, 192kHz
 - 11: 256fs output: When receiving 32kHz, 44.1kHz, 48kHz
 512fs output: When receiving 64kHz, 88.2kHz, 96kHz
 128fs output: When receiving 128kHz, 176.4kHz, 192kHz
- PRSEL[1:0]** PLL lock time MCKO output setting when PLLACC is set to "1"
- 00: 256fs output (initial value)
 - 01: 512fs output
 - 10: 128fs output
 - 11: Reserved
- XOUTCK** XIN clock output setting when PLL is unlocked
- 0: MCKO=24.576MHz, BCKO=6.144MHz, LRCKO=96kHz (initial value)
 - 1: MCKO=24.576MHz, BCKO=3.072MHz, LRCKO=48kHz

LC89091JA

Address: 02h; Data setting

| 02h | D7 | D6 | D5 | D4 | D3 | D2 | D1 | D0 |
|---------------|--------|--------|---------|---------|--------|--------|--------|--------|
| Register name | NPMODE | ERRSEL | GPOSEL1 | GPOSEL0 | DATMUT | THRSEL | DINSEL | DAFORM |
| Initial value | 0 | 0 | 0 | 0 | 0 | 0 | 0 | 0 |
| Setting | R/W | R/W | R/W | R/W | R/W | R/W | R/W | R/W |

- DAFORM** Audio data output format setting
0: I²S data output (initial value)
1: 24-bit MSB first, left-justified data output
- DINSEL** Data demodulation input setting
0: RXIN (initial value)
1: MPIO (when "MPSEL=1")
- THRSEL** GPO output data setting when "GPOSEL[1:0]=01"
0: RXIN (initial value)
1: MPIO (when "MPSEL=1")
- DATMUT** DATAO pin output setting
0: Output SDIN data while PLL is unlocked (initial value)
1: Mute, "L" output
- GPOSEL[1:0]** GPO output data setting
00: Channel status bit 1 output (initial value)
01: Input S/PDIF through output
10: "L" output
11: "H" output
- ERRSEL** ERR pin output setting
0: PLL lock error or transfer data parity error output (initial value)
1: DATAO data mute signal output
- NPMODE** DATAO pin output setting when S/PDIF non-PCM data is received
0: Output (initial value)
1: Mute, "L" output

- When MPIO is no-load at an output setup, don't choose MPIO by DINSEL or THRSEL register.
- DATAO is muted when non-PCM data is detected at "NPMODE=1". But, due to it is not a data error, ERR output PLL lock state ("L" output).

LC89091JA

Address: 03h; Input fs calculation value

| 03h | D7 | D6 | D5 | D4 | D3 | D2 | D1 | D0 |
|---------------|----|----|----|--------|------|------|------|------|
| Register name | 0 | 0 | 0 | ERRFLG | FSC3 | FSC2 | FSC1 | FSC0 |
| Setting | R | R | R | R | R | R | R | R |

FSC[3:0] Input data fs calculation result read

0000: 44.1kHz

0001: Out of range

0010: 48kHz

0011: 32kHz

0100: -

0101: -

0110: -

0111: -

1000: 88.2kHz

1001: -

1010: 96kHz

1011: 64kHz

1100: 176.4kHz

1101: 128kHz

1110: 192kHz

1111: -

ERRFLG ERR pin output read (It can be read when "ERRSEL=1")

0: No transfer error while PLL is locked

1: Transfer error exists or PLL is unlocked

LC89091JA

Address: 04h to 08h; Channel status information (read only)

| Address | D7 | D6 | D5 | D4 | D3 | D2 | D1 | D0 |
|---------|------|------|------|------|------|------|------|------|
| 04h | CS7 | CS6 | CS5 | CS4 | CS3 | CS2 | CS1 | CS0 |
| 05h | CS15 | CS14 | CS13 | CS12 | CS11 | CS10 | CS9 | CS8 |
| 06h | CS23 | CS22 | CS21 | CS20 | CS19 | CS18 | CS17 | CS16 |
| 07h | CS31 | CS30 | CS29 | CS28 | CS27 | CS26 | CS25 | CS24 |
| 08h | CS39 | CS38 | CS37 | CS36 | CS35 | CS34 | CS33 | CS32 |

Table 9.2: Channel Status Register Contents

| Adr | Reg | CS Bit | Description | Adr | Reg | CS Bit | Description |
|-----|------|--------|----------------|-----|------|--------|-----------------------------|
| 04h | CS0 | bit0 | Application | 07h | CS24 | bit24 | Sampling frequency |
| | CS1 | bit1 | Control | | CS25 | bit25 | |
| | CS2 | bit2 | | | CS26 | bit26 | |
| | CS3 | bit3 | | | CS27 | bit27 | |
| | CS4 | bit4 | | | CS28 | bit32 | Clock accuracy |
| | CS5 | bit5 | | | CS29 | bit33 | |
| | CS6 | bit6 | Not defined | | CS30 | bit30 | Not defined |
| | CS7 | bit7 | | | CS31 | bit31 | |
| 05h | CS8 | bit8 | Category code | 08h | CS32 | bit32 | Bit width |
| | CS9 | bit9 | | | CS33 | bit33 | |
| | CS10 | bit10 | | | CS34 | bit34 | |
| | CS11 | bit11 | | | CS35 | bit35 | |
| | CS12 | bit12 | | | CS36 | bit36 | Original sampling frequency |
| | CS13 | bit13 | | | CS37 | bit37 | |
| | CS14 | bit14 | | | CS38 | bit38 | |
| | CS15 | bit15 | | | CS39 | bit39 | |
| 06h | CS16 | bit16 | Source number | | | | |
| | CS17 | bit17 | | | | | |
| | CS18 | bit18 | | | | | |
| | CS19 | bit19 | | | | | |
| | CS20 | bit20 | Channel number | | | | |
| | CS21 | bit21 | | | | | |
| | CS22 | bit22 | | | | | |
| | CS23 | bit23 | | | | | |

- For details, check the IEC60958 Specifications

10. Application Circuit Example

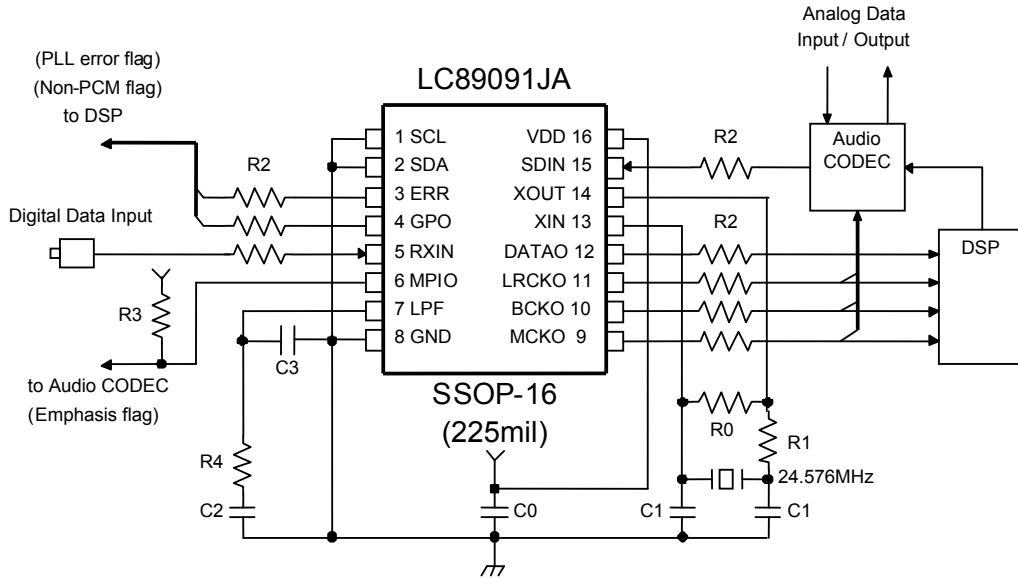

(1) Example of microcontroller interface is not used

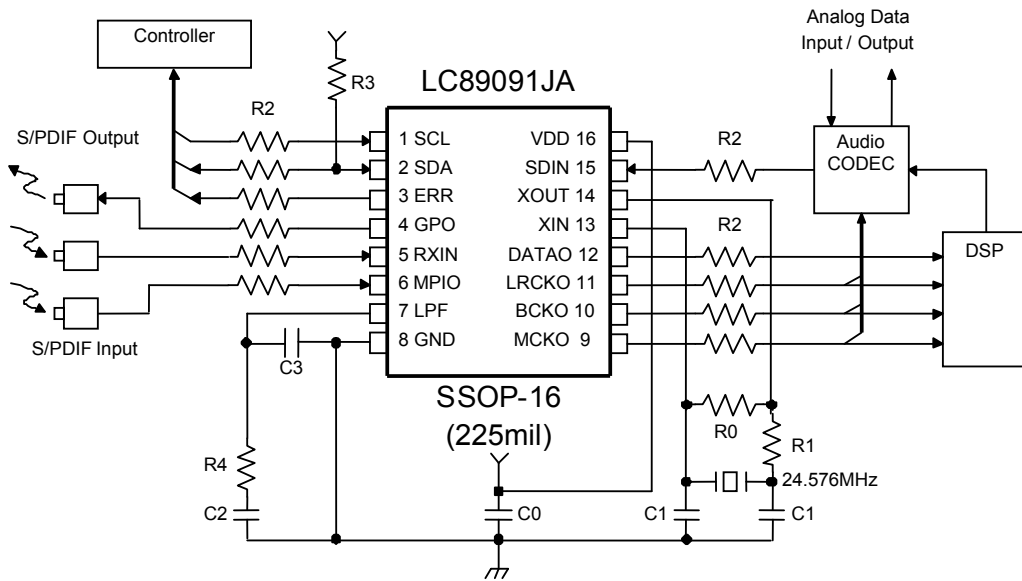

(2) Example of microcontroller interface is used

| Element Symbol | Recommended Parameter | Application | Remarks |
|----------------|-------------------------------|-------------------------------------|--|
| C0 | 0.01 μ F to 0.1 μ F | Power supply de-coupling | Ceramic capacitor |
| R0 | 1M Ω | Oscillation amplifier feedback | |
| R1 | 150 Ω to 2.2k Ω | Oscillation amplifier current limit | |
| C1 | 1pF to 33pF | Quartz resonator load | Ceramic capacitor with NP0 characteristics |
| R2 | 0 Ω to 100 Ω | Damping resistor | |
| R3 | 10k Ω to 100k Ω | Pull-up resistor | |
| R4 | 100 Ω | PLL loop filter | See 8.4 |
| C2 | 0.1 μ F | PLL loop filter | See 8.4 |
| C3 | 0.022 μ F | PLL loop filter | See 8.4 |

Figure 10.1: LC89091JA Application Circuit Example

LC89091JA

ORDERING INFORMATION

| Device | Package | Shipping (Qty / Packing) |
|--------------|--|--------------------------|
| LC89091JA-AH | SSOP16(225mil) (Pb-Free / Halogen Free) | 2000 / Tape & Reel |
| LC89091JA-H | SSOP16(225mil) (Pb-Free / Halogen Free) | 90 / Fan-Fold |

ON Semiconductor and the ON logo are registered trademarks of Semiconductor Components Industries, LLC (SCILLC). SCILLC owns the rights to a number of patents, trademarks, copyrights, trade secrets, and other intellectual property. A listing of SCILLC's product/patent coverage may be accessed at www.onsemi.com/site/pdf/Patent-Marking.pdf. SCILLC reserves the right to make changes without further notice to any products herein. SCILLC makes no warranty, representation or guarantee regarding the suitability of its products for any particular purpose, nor does SCILLC assume any liability arising out of the application or use of any product or circuit, and specifically disclaims any and all liability, including without limitation special, consequential or incidental damages. "Typical" parameters which may be provided in SCILLC data sheets and/or specifications can and do vary in different applications and actual performance may vary over time. All operating parameters, including "Typicals" must be validated for each customer application by customer's technical experts. SCILLC does not convey any license under its patent rights nor the rights of others. SCILLC products are not designed, intended, or authorized for use as components in systems intended for surgical implant into the body, or other applications intended to support or sustain life, or for any other application in which the failure of the SCILLC product could create a situation where personal injury or death may occur. Should Buyer purchase or use SCILLC products for any such unintended or unauthorized application, Buyer shall indemnify and hold SCILLC and its officers, employees, subsidiaries, affiliates, and distributors harmless against all claims, costs, damages, and expenses, and reasonable attorney fees arising out of, directly or indirectly, any claim of personal injury or death associated with such unintended or unauthorized use, even if such claim alleges that SCILLC was negligent regarding the design or manufacture of the part. SCILLC is an Equal Opportunity/Affirmative Action Employer. This literature is subject to all applicable copyright laws and is not for resale in any manner.