

LAN8810/LAN8810i

GMII 10/100/1000 Ethernet Transceiver with HP Auto-MDIX Support

PRODUCT FEATURES

Datasheet

Highlights

- Single-Chip Ethernet Physical Layer Transceiver (PHY)
- Compliant with IEEE 802.3ab (1000BASE-T), IEEE 802.3u (Fast Ethernet), and ISO 802-3/IEEE 802.3 (10BASE-T)
- HP Auto-MDIX support in accordance with IEEE 802.3ab specification at 10/100/1000 Mbps operation
- Small footprint 72-pin QFN lead-free RoHS compliant package with GMII (10 x 10 x 0.9mm height)
- Flexible configurations for LED status indicators
- Implements Reduced Power Operating Modes

Target Applications

- Set-Top Boxes
- Networked Printers and Servers
- Test Instrumentation
- LAN on Motherboard
- Embedded Telecom Applications
- Video Record/Playback Systems
- Cable Modems/Routers
- DSL Modems/Routers
- Digital Video Recorders
- IP and Video Phones
- Wireless Access Points
- Digital Televisions
- Digital Media Adaptors/Servers
- Gaming Consoles
- POE Applications

Key Benefits

- High-Performance 10/100/1000 Ethernet Transceiver
 - Compliant with IEEE 802.3ab (1000BASE-T)
 - Compliant with IEEE 802.3/802.3u (Fast Ethernet)
 - Compliant with ISO 802-3/IEEE 802.3 (10BASE-T)
 - 10BASE-T, 100BASE-TX and 1000BASE-T support
 - Loop-back modes
 - Auto-negotiation (NEXT page support)
 - Automatic polarity detection and correction
 - Link status change wake-up detection
 - Vendor specific register functions
 - Supports GMII interface
 - Controlled impedance outputs
 - Four status LED outputs and configurable LED modes with support for tricolor operation
 - Compliant with IEEE 802.3-2005 standards
 - GMII pins tolerant to 3.6V
 - Integrated DSP implements adaptive equalizer, echo cancellers, and crosstalk cancellers
 - Efficient digital baseline wander correction
- Power and I/Os
 - Configurable LED outputs
 - Various low power modes
 - Variable voltage I/O supply (2.5V/3.3V)
- Miscellaneous Features
 - IEEE 1149.1 (JTAG) boundary scan
 - Multiple clock options - 25MHz crystal or 125MHz clock
- Packaging
 - 72-pin QFN (10x10 mm) lead-free RoHS compliant package with GMII
- Environmental
 - Commercial temperature range (0°C to +70°C)
 - Industrial temperature range (-40°C to +85°C)

Datasheet

Order Numbers:

LAN8810-AKZE for 72-pin, QFN lead-free RoHS compliant package (0 to +70°C temp range)

LAN8810i-AKZE for 72-pin, QFN lead-free RoHS compliant package (-40 to +85°C temp range)

This product meets the halogen maximum concentration values per IEC61249-2-21

For RoHS compliance and environmental information, please visit www.smSC.com/rohs

Please contact your SMSC sales representative for additional documentation related to this product such as application notes, anomaly sheets, and design guidelines.

Copyright © 2013 SMSC or its subsidiaries. All rights reserved.

Circuit diagrams and other information relating to SMSC products are included as a means of illustrating typical applications. Consequently, complete information sufficient for construction purposes is not necessarily given. Although the information has been checked and is believed to be accurate, no responsibility is assumed for inaccuracies. SMSC reserves the right to make changes to specifications and product descriptions at any time without notice. Contact your local SMSC sales office to obtain the latest specifications before placing your product order. The provision of this information does not convey to the purchaser of the described semiconductor devices any licenses under any patent rights or other intellectual property rights of SMSC or others. All sales are expressly conditional on your agreement to the terms and conditions of the most recently dated version of SMSC's standard Terms of Sale Agreement dated before the date of your order (the "Terms of Sale Agreement"). The product may contain design defects or errors known as anomalies which may cause the product's functions to deviate from published specifications. Anomaly sheets are available upon request. SMSC products are not designed, intended, authorized or warranted for use in any life support or other application where product failure could cause or contribute to personal injury or severe property damage. Any and all such uses without prior written approval of an Officer of SMSC and further testing and/or modification will be fully at the risk of the customer. Copies of this document or other SMSC literature, as well as the Terms of Sale Agreement, may be obtained by visiting SMSC's website at <http://www.smSC.com>. SMSC is a registered trademark of Standard Microsystems Corporation ("SMSC"). Product names and company names are the trademarks of their respective holders.

The Microchip name and logo, and the Microchip logo are registered trademarks of Microchip Technology Incorporated in the U.S.A. and other countries.

SMSC DISCLAIMS AND EXCLUDES ANY AND ALL WARRANTIES, INCLUDING WITHOUT LIMITATION ANY AND ALL IMPLIED WARRANTIES OF MERCHANTABILITY, FITNESS FOR A PARTICULAR PURPOSE, TITLE, AND AGAINST INFRINGEMENT AND THE LIKE, AND ANY AND ALL WARRANTIES ARISING FROM ANY COURSE OF DEALING OR USAGE OF TRADE. IN NO EVENT SHALL SMSC BE LIABLE FOR ANY DIRECT, INCIDENTAL, INDIRECT, SPECIAL, PUNITIVE, OR CONSEQUENTIAL DAMAGES; OR FOR LOST DATA, PROFITS, SAVINGS OR REVENUES OF ANY KIND; REGARDLESS OF THE FORM OF ACTION, WHETHER BASED ON CONTRACT; TORT; NEGLIGENCE OF SMSC OR OTHERS; STRICT LIABILITY; BREACH OF WARRANTY; OR OTHERWISE; WHETHER OR NOT ANY REMEDY OF BUYER IS HELD TO HAVE FAILED OF ITS ESSENTIAL PURPOSE, AND WHETHER OR NOT SMSC HAS BEEN ADVISED OF THE POSSIBILITY OF SUCH DAMAGES.

Table of Contents

Chapter 1	Introduction	8
1.1	General Description	8
Chapter 2	Pin Description and Configuration	10
2.1	Buffer Types	18
Chapter 3	Functional Description	19
3.1	Auto-negotiation	19
3.1.1	Restarting Auto-negotiation	20
3.1.2	Disabling Auto-negotiation	20
3.1.3	Parallel Detection	20
3.1.4	Master/Slave	20
3.1.5	Manual Operation	21
3.1.6	Half vs. Full-Duplex	21
3.2	HP Auto-MDIX	22
3.2.1	Required Ethernet Magnetics	23
3.3	GMII Interface	24
3.3.1	MII Isolate Mode	24
3.4	Serial Management Interface (SMI)	25
3.5	Interrupt Management	26
3.6	Resets	27
3.6.1	Hardware Reset (nRESET)	27
3.6.2	Software Reset	27
3.6.3	Power-Down Reset	27
3.7	Power-Down modes	28
3.7.1	General Power-Down	28
3.7.2	Energy Detect Power-Down	28
3.7.3	Hardware Power-Down	28
3.8	Configuration	29
3.8.1	Hardware Configuration	29
3.8.2	Software Configuration	33
3.9	Miscellaneous Functions	34
3.9.1	LEDs	34
3.9.2	Variable Voltage I/O	35
3.9.3	Isolate Mode	36
3.9.4	Carrier Sense	36
3.9.5	Collision Detect	36
3.9.6	Link Integrity	36
3.9.7	Speed Optimizer	38
3.9.8	Loopback Operation	38
3.9.9	IEEE 1149.1 (JTAG) Boundary Scan	39
3.9.10	Advanced Features	39
3.10	Application Diagrams	41
3.10.1	Simplified Application Diagram	41
3.10.2	Power Supply & Twisted Pair Interface Diagram	42
Chapter 4	Register Descriptions	43
4.1	Register Nomenclature	43
4.2	Primary PHY Registers	44
4.2.1	Basic Control Register	45
4.2.2	Basic Status Register	46

Datasheet

4.2.3	PHY Identifier 1 Register	47
4.2.4	PHY Identifier 2 Register	48
4.2.5	Auto Negotiation Advertisement Register	49
4.2.6	Auto Negotiation Link Partner Ability Register	50
4.2.7	Auto Negotiation Expansion Register	51
4.2.8	Auto Negotiation Next Page TX Register	52
4.2.9	Auto Negotiation Next Page RX Register	53
4.2.10	Master/Slave Control Register	54
4.2.11	Master/Slave Status Register	55
4.2.12	Extended Status Register	56
4.2.13	Link Control Register	57
4.2.14	10/100 Mode Control/Status Register	58
4.2.15	10/100 Special Modes Register	60
4.2.16	Extended Mode Control/Status Register	61
4.2.17	Advanced Register Address Port	62
4.2.18	Advanced Register Read Data Port	63
4.2.19	Control / Status Indications Register	64
4.2.20	Interrupt Source Flags Register	65
4.2.21	Interrupt Mask Register	66
4.2.22	PHY Special Control / Status Register	67
4.3	Advanced PHY Registers	68
4.3.1	Advanced Register Mapping	68
4.3.2	User Status 1 Register	69
4.3.3	User Status 2 Register	70
4.3.4	Receive Error-Free Packets Counter High Register	71
4.3.5	Receive Error-Free Packets Counter Mid Register	72
4.3.6	Receive Error-Free Packets Counter Low Register	73
4.3.7	CRC Error Counter High Register	74
4.3.8	CRC Error Counter Mid Register	75
4.3.9	CRC Error Counter Low Register	76
4.3.10	Receive Error During Data Counter Register	77
4.3.11	Receive Error During Idle Counter Register	78
4.3.12	Transmit Packet Counter High Register	79
4.3.13	Transmit Packet Counter Mid Register	80
4.3.14	Transmit Packet Counter Low Register	81

Chapter 5 Operational Characteristics 82

5.1	Absolute Maximum Ratings*	82
5.2	Operating Conditions**	83
5.3	Power Consumption	83
5.4	DC Specifications	85
5.5	AC Specifications	87
5.5.1	Equivalent Test Load	87
5.5.2	Power Sequence Timing	88
5.5.3	Power-On Reset Timing	89
5.5.4	Reset Timing	90
5.5.5	GMII Timing (1000BASE-T)	91
5.5.6	MII Timing (100BASE-TX, 10BASE-T)	93
5.5.7	SMI Timing	95
5.5.8	JTAG Timing	96
5.6	Clock Circuit	97

Chapter 6 Package Outline 98

6.1	72-QFN Package	98
-----	--------------------------	----

Chapter 7 Datasheet Revision History..... 100

Datasheet**List of Figures**

Figure 1.1	Internal Block Diagram	8
Figure 1.2	System Level Block Diagram	9
Figure 2.1	72-QFN Pin Assignments (TOP VIEW)	10
Figure 3.1	Cable Connection Types: Straight-Through, Crossover, Semi Crossover	23
Figure 3.1	MDIO Timing and Frame Structure - READ Cycle	25
Figure 3.2	MDIO Timing and Frame Structure - WRITE Cycle	25
Figure 3.1	Simplified Application Diagram	41
Figure 3.2	Power Supply & Twisted Pair Interface Diagram	42
Figure 5.1	Output Equivalent Test Load	87
Figure 5.2	Power Sequence Timing	88
Figure 5.3	Power-On Reset Timing	89
Figure 5.4	Reset Timing	90
Figure 5.5	GMII Transmit Timing	91
Figure 5.6	GMII Receive Timing	92
Figure 5.7	MII Receive Timing	93
Figure 5.8	MII Transmit Timing	94
Figure 5.9	SMI Timing	95
Figure 5.10	JTAG Timing	96
Figure 6.1	72-QFN Package	98
Figure 6.2	72-QFN Recommended PCB Land Pattern	99

List of Tables

Table 2.1	GMII Interface Pins	11
Table 2.2	Serial Management Interface (SMI) Pins	12
Table 2.3	LED & Configuration Pins	13
Table 2.4	Ethernet Pins	14
Table 2.5	JTAG Pins	15
Table 2.6	Miscellaneous Pins	15
Table 2.7	Power Pins	16
Table 2.8	72-QFN Pin Assignments	17
Table 2.9	Buffer Types	18
Table 3.1	Master/Slave Resolution for 1000BASE-T	21
Table 3.2	CRS Behavior	22
Table 3.3	GMII/MII Signal Mapping	24
Table 3.4	Interrupt Management Table	26
Table 3.5	Configuration Straps	29
Table 3.6	Hardware Connection Determines Configuration Pin Value (CPV)	30
Table 3.7	SMI Address Configuration with PAUSE=0	30
Table 3.8	SMI Address Configuration with PAUSE=1	31
Table 3.9	Configuring the Mode of Operation with MACCLKDIS=0	32
Table 3.10	Configuring the Mode of Operation with MACCLKDIS=1	32
Table 3.11	Register Bits Impacted by the Mode of Operation (MOD)	33
Table 3.12	LED Mode 1 Operation - LED_MODE[1:0]=01b	34
Table 3.13	LED Mode 2 Operation - LED_MODE[1:0]=10b	35
Table 3.14	LED Mode 3 Operation - LED_MODE[1:0]=11b	35
Table 3.15	IEEE 1149.1 Op Codes	39
Table 4.1	Register Bit Types	43
Table 4.2	PHY Control and Status Registers	44
Table 4.3	Advanced Register Mapping	68
Table 5.1	Power Consumption - 1000BASE-T Linked	83
Table 5.2	Power Consumption - 100BASE-TX Linked	83
Table 5.3	Power Consumption - 10BASE-T Linked	84
Table 5.4	Power Consumption - Energy Detect	84
Table 5.5	Power Consumption - Hardware Power Down (PLL Enabled)	84
Table 5.6	Power Consumption - Hardware Power Down (PLL Disabled)	85
Table 5.7	I/O Buffer Characteristics	85
Table 5.8	1000BASE-T Transceiver Characteristics	86
Table 5.9	100BASE-TX Transceiver Characteristics	86
Table 5.10	10BASE-T Transceiver Characteristics	86
Table 5.11	Power Sequence Timing Values	88
Table 5.12	Power-On Reset Timing Values	89
Table 5.13	Reset Timing Values	90
Table 5.14	GMII Transmit Timing Values	91
Table 5.15	GMII Receive Timing Values	92
Table 5.16	MII Receive Timing Values	93
Table 5.17	MII Transmit Timing Values	94
Table 5.18	SMI Timing Values	95
Table 5.19	JTAG Timing Values	96
Table 5.20	Crystal Specifications	97
Table 6.1	72-QFN Dimensions	98
Table 7.1	Customer Revision History	100

Chapter 1 Introduction

1.1 General Description

The SMSC LAN8810/LAN8810i is a low-power 10BASE-T/100BASE-TX/1000BASE-T Gigabit Ethernet physical layer (PHY) transceiver with variable I/O voltage that is fully compliant with the IEEE 802.3 and 802.3ab standards.

The LAN8810/LAN8810i can be configured to communicate with an Ethernet MAC via the standard MII(IEEE 802.3u)/GMII(IEEE 802.3z) interfaces. It contains a full-duplex transceiver for 1000Mbps operation on four pairs of category 5 or better balanced twisted pair cable. Per IEEE 802.3-2005 standards, all digital interface pins are tolerant to 3.6V.

The LAN8810/LAN8810i is configurable via hardware and software, supporting both IEEE 802.3-2005 compliant and vendor-specific register functions via SMI. The LAN8810/LAN8810i implements Auto-Negotiation to automatically determine the best possible speed and duplex mode of operation. HP Auto-MDIX support allows the use of direct connect or cross-over cables.

An internal block diagram of the LAN8810/LAN8810i is shown in [Figure 1.1](#). A typical system-level diagram is shown in [Figure 1.2](#).

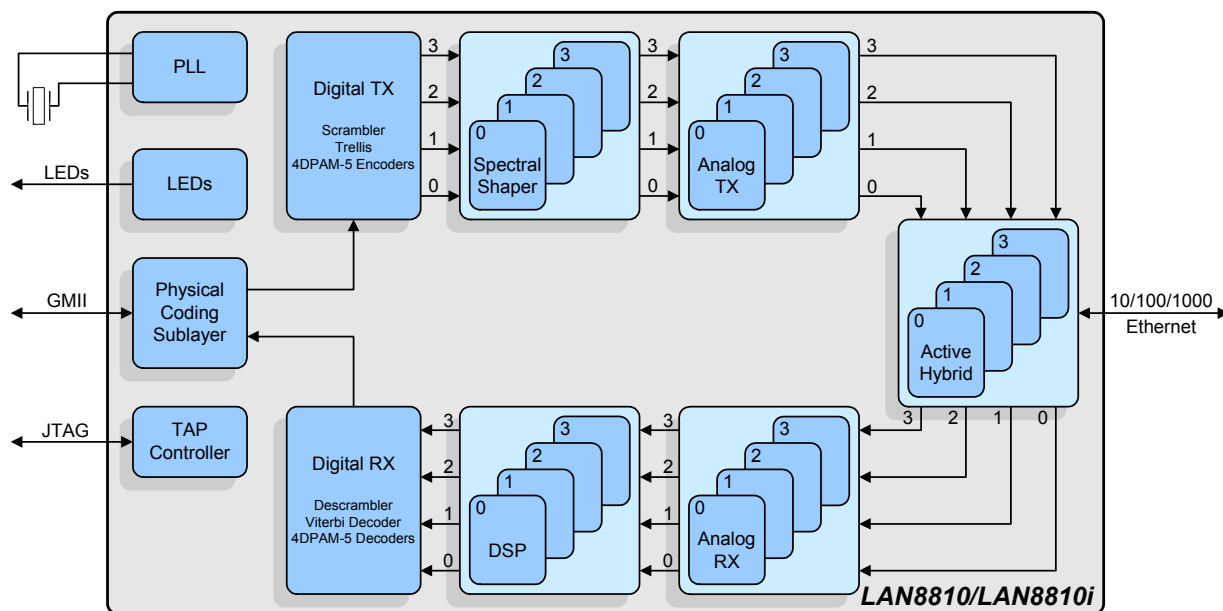

Figure 1.1 Internal Block Diagram

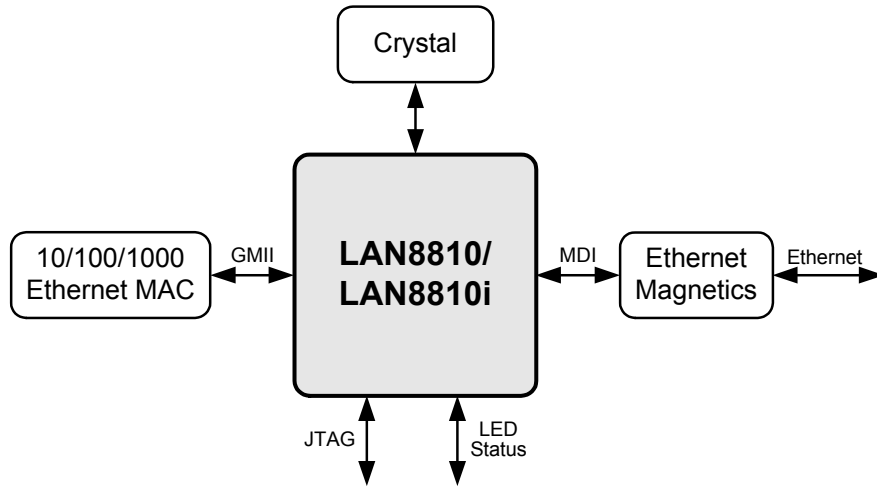
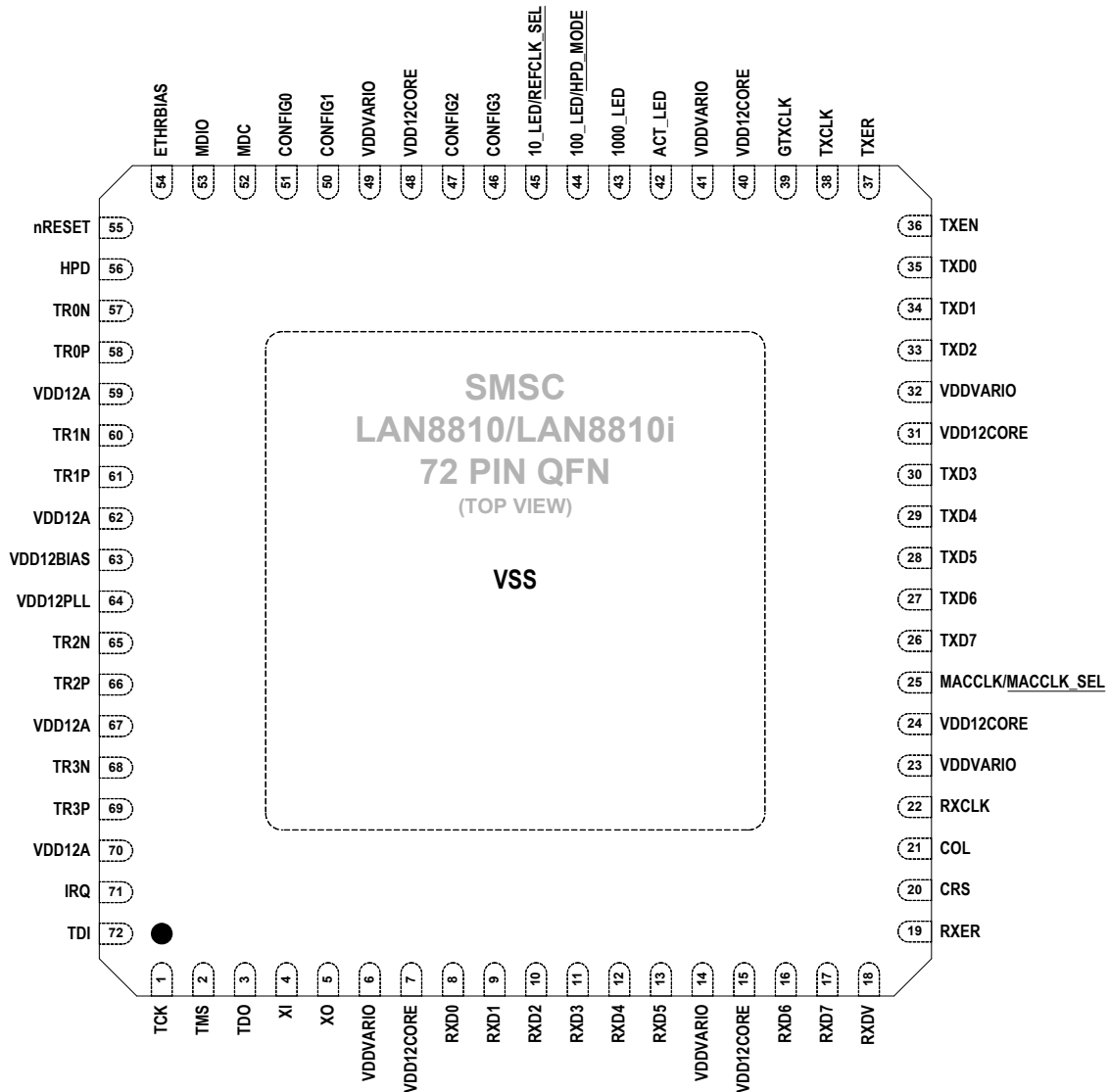

Figure 1.2 System Level Block Diagram

Chapter 2 Pin Description and Configuration



NOTE: Exposed pad (VSS) on bottom of package must be connected to ground

Figure 2.1 72-QFN Pin Assignments (TOP VIEW)

Table 2.1 GMII Interface Pins

NUM PINS	NAME	SYMBOL	BUFFER TYPE	DESCRIPTION
1	Transmit Data 0	TXD0	VIS (PD)	The MAC transmits data to the PHY using this signal.
1	Transmit Data 1	TXD1	VIS (PD)	The MAC transmits data to the PHY using this signal.
1	Transmit Data 2	TXD2	VIS (PD)	The MAC transmits data to the PHY using this signal.
1	Transmit Data 3	TXD3	VIS (PD)	The MAC transmits data to the PHY using this signal.
1	Transmit Data 4	TXD4	VIS (PD)	The MAC transmits data to the PHY using this signal.
1	Transmit Data 5	TXD5	VIS (PD)	The MAC transmits data to the PHY using this signal.
1	Transmit Data 6	TXD6	VIS (PD)	The MAC transmits data to the PHY using this signal.
1	Transmit Data 7	TXD7	VIS (PD)	The MAC transmits data to the PHY using this signal.
1	Transmit Error	TXER	VIS (PD)	Indicates a transmit error condition. Note: This input is ignored during 10BASE-T operation.
1	Transmit Enable	TXEN	VIS (PD)	Indicates the presence of valid data on TXD[7:0]
1	Transmit Clock	TXCLK	VO8	Used to latch data from the MAC into the PHY. MII (100BASE-TX): 25MHz MII (10BASE-T): 2.5MHz Note: For 1000BASE-T operation, GTXCLK is used as the transmit clock. TXCLK is not used in 1000BASE-T mode.
1	GMII Transmit Clock	GTXCLK	VIS (PD)	125MHz clock used to latch data from the MAC into the PHY in 1000BASE-T mode.
1	Receive Data 0	RXD0	VO6	The PHY transfers data to the MAC using this signal.
1	Receive Data 1	RXD1	VO6	The PHY transfers data to the MAC using this signal.
1	Receive Data 2	RXD2	VO6	The PHY transfers data to the MAC using this signal.
1	Receive Data 3	RXD3	VO6	The PHY transfers data to the MAC using this signal.
1	Receive Data 4	RXD4	VO6	The PHY transfers data to the MAC using this signal.
1	Receive Data 5	RXD5	VO6	The PHY transfers data to the MAC using this signal.

Datasheet

Table 2.1 GMII Interface Pins (continued)

NUM PINS	NAME	SYMBOL	BUFFER TYPE	DESCRIPTION
1	Receive Data 6	RXD6	VO6	The PHY transfers data to the MAC using this signal.
1	Receive Data 7	RXD7	VO6	The PHY transfers data to the MAC using this signal.
1	Receive Data Valid	RXDV	VO6	Indicates that recovered and decoded data is being presented on the receive data pins.
1	Receive Error	RXER	VO6	Asserted to indicate an error has been detected in the frame presently being transferred from the PHY.
1	Receive Clock	RXCLK	VO6	Used to transfer data to the MAC. GMII (1000BASE-T): 125MHz MII (100BASE-TX): 25MHz MII (10BASE-T): 2.5MHz
1	Collision Detect	COL	VO6	Asserted to indicate detection of a collision condition. (used in half-duplex mode only)
1	Carrier Sense	CRS	VO6	Indicates detection of carrier. (used in half-duplex mode only)
1	MAC Transmit Clock	MACCLK	VO6	125MHz or 25MHz selectable MAC clock output as required by clause 40.6.1.2.5 of the IEEE 802.3ab specification.
	MAC Clock Frequency Select Configuration Strap	<u>MACCLK_SEL</u>	VIS (PD)	This configuration strap is used to select the output frequency of MACCLK. When pulled-up to VDDVARIO, 25MHz is selected. When pulled-down to VSS, 125MHz is selected. See Note 2.1 for more information on configuration straps.

Note 2.1 Configuration strap values are latched on hardware reset. Configuration straps are identified by an underlined symbol name. Signals that function as configuration straps must be augmented with an external resistor when connected to a load. Refer to [Section 3.8, "Configuration,"](#) on page 29 for additional information.

Table 2.2 Serial Management Interface (SMI) Pins

NUM PINS	NAME	SYMBOL	BUFFER TYPE	DESCRIPTION
1	SMI Clock	MDC	VIS (PD)	Serial Management Interface clock.
1	SMI Data Input/Output	MDIO	VIS/VO8 (PU)	Serial Management Interface data input/output.

Table 2.3 LED & Configuration Pins

NUM PINS	NAME	SYMBOL	BUFFER TYPE	DESCRIPTION
1	10BASE-T Link LED Indicator	10_LED	VO8	10BASE-T LED link indication. Refer to Section 3.9.1, "LEDs," on page 34 for additional information.
	Reference Clock Freq. Select Configuration Strap	<u>REFCLK_SEL</u>	VIS (PD)	This configuration strap is used to select the reference clock frequency. When pulled-up, a 125MHz reference clock is selected. When pulled-down, a 25MHz reference clock is selected. See Note 2.2 for more information on configuration straps.
1	100BASE-TX Link LED Indicator	100_LED	VO8	100BASE-TX LED link indication. Refer to Section 3.9.1, "LEDs," on page 34 for additional information.
	Hardware Power Down (HPD) Mode Configuration Strap	<u>HPD_MODE</u>	VIS (PD)	This configuration strap is used to select the Hardware Power Down (HPD) mode. When pulled-up, the PLL is not disabled when HPD is asserted. When pulled-down, the PLL is disabled when HPD is asserted. Refer to Section 3.7.3, "Hardware Power-Down," on page 28 for additional information. See Note 2.2 for more information on configuration straps.
1	1000BASE-T Link LED Indicator	1000_LED	VO8	1000BASE-T LED link indication. Refer to Section 3.9.1, "LEDs," on page 34 for additional information.
1	Link Activity LED Indicator	ACT_LED	VO8	Link activity LED indication. Refer to Section 3.9.1, "LEDs," on page 34 for additional information.
1	Configuration Input 0	CONFIG0	VIS (PD)	This pin sets the PHYADD[1:0] bits of the 10/100 Special Modes Register on reset or power-up. It must be connected to VSS, 100_LED, 1000_LED, or VDDVARIO. Refer to Section 3.8.1.2, "CONFIG[3:0] Configuration Pins," on page 29 for additional information.
1	Configuration Input 1	CONFIG1	VIS (PD)	This pin sets the PAUSE bit of the Auto Negotiation Advertisement Register and PHYADD [2] bit of the 10/100 Special Modes Register on reset or power-up. It must be connected to VSS, 100_LED, 1000_LED, or VDDVARIO. Refer to Section 3.8.1.2, "CONFIG[3:0] Configuration Pins," on page 29 for additional information.
1	Configuration Input 2	CONFIG2	VIS (PD)	This pin sets the MOD[1:0] bits of the Extended Mode Control/Status Register on reset or power-up. It must be connected to VSS, 100_LED, 1000_LED, or VDDVARIO. Refer to Section 3.8.1.2, "CONFIG[3:0] Configuration Pins," on page 29 for additional information.
1	Configuration Input 3	CONFIG3	VIS (PD)	This pin sets the CLK125DIS bit and MOD[3] bit of the Extended Mode Control/Status Register on reset or power-up. It must be connected to VSS, 100_LED, 1000_LED, or VDDVARIO. Refer to Section 3.8.1.2, "CONFIG[3:0] Configuration Pins," on page 29 for additional information.

Datasheet

Note 2.2 Configuration strap values are latched on hardware reset. Configuration straps are identified by an underlined symbol name. Signals that function as configuration straps must be augmented with an external resistor when connected to a load. Refer to [Section 3.8, "Configuration,"](#) on page 29 for additional information.

Table 2.4 Ethernet Pins

NUM PINS	NAME	SYMBOL	BUFFER TYPE	DESCRIPTION
1	Ethernet TX/RX Positive Channel 0	TR0P	AIO	Transmit/Receive Positive Channel 0.
1	Ethernet TX/RX Negative Channel 0	TR0N	AIO	Transmit/Receive Negative Channel 0.
1	Ethernet TX/RX Positive Channel 1	TR1P	AIO	Transmit/Receive Positive Channel 1.
1	Ethernet TX/RX Negative Channel 1	TR1N	AIO	Transmit/Receive Negative Channel 1.
1	Ethernet TX/RX Positive Channel 2	TR2P	AIO	Transmit/Receive Positive Channel 2.
1	Ethernet TX/RX Negative Channel 2	TR2N	AIO	Transmit/Receive Negative Channel 2.
1	Ethernet TX/RX Positive Channel 3	TR3P	AIO	Transmit/Receive Positive Channel 3.
1	Ethernet TX/RX Negative Channel 3	TR3N	AIO	Transmit/Receive Negative Channel 3.
1	External PHY Bias Resistor	ETHRBIAS	AI	Used for the internal bias circuits. Connect to an external 8.06K 1.0% resistor to ground.

Table 2.5 JTAG Pins

NUM PINS	NAME	SYMBOL	BUFFER TYPE	DESCRIPTION
1	JTAG Test Data Out	TDO	VO8	JTAG (IEEE 1149.1) data output.
1	JTAG Test Data Input	TDI	VIS (PU)	JTAG (IEEE 1149.1) data input. Note: When not used, tie this pin to VDDVARIO.
1	JTAG Test Clock	TCK	VIS (PD)	JTAG (IEEE 1149.1) test clock. Note: When not used, tie this pin to VSS.
1	JTAG Test Mode Select	TMS	VIS (PU)	JTAG (IEEE 1149.1) test mode select. Note: When not used, tie this pin to VDDVARIO.

Table 2.6 Miscellaneous Pins

NUM PINS	NAME	SYMBOL	BUFFER TYPE	DESCRIPTION
1	Crystal Input	XI	ICLK	External 25 MHz crystal input. Note: This pin can also be driven by a single-ended clock oscillator. When this method is used, XO should be left unconnected
1	Crystal Output	XO	OCLK	External 25 MHz crystal output.
1	System Reset	nRESET	VIS (PU)	This active-low pin allows external hardware to reset the device.
1	Interrupt Request	IRQ	VO8	Programmable interrupt request. Note: When used, this pin requires an external 4.7K pull-up resistor.
1	Hardware Power Down	HPD	VIS (PD)	When asserted, this pin places the device into Hardware Power Down (HPD) mode. Refer to Section 3.7.3, "Hardware Power-Down," on page 28 for additional information.

Datasheet

Table 2.7 Power Pins

NUM PINS	NAME	SYMBOL	BUFFER TYPE	DESCRIPTION
6	+3.3V/+2.5V I/O Power Supply Input	VDDVARIO	P	+2.5V/+3.3V variable I/O power. Refer to Section 3.10, "Application Diagrams," on page 41 and the LAN8810/LAN8810i reference schematics for connection information.
6	Digital Core +1.2V Power Supply Input	VDD12CORE	P	Refer to Section 3.10, "Application Diagrams," on page 41 and the LAN8810/LAN8810i reference schematics for connection information.
4	Ethernet +1.2V Port Power Supply Input For Channels 0-3	VDD12A	P	Refer to Section 3.10, "Application Diagrams," on page 41 and the LAN8810/LAN8810i reference schematics for connection information.
1	Ethernet +1.2V Bias Power Supply Input	VDD12BIAS	P	Refer to Section 3.10, "Application Diagrams," on page 41 and the LAN8810/LAN8810i reference schematics for connection information.
1	Ethernet PLL +1.2V Power Supply Input	VDD12PLL	P	Refer to Section 3.10, "Application Diagrams," on page 41 and the LAN8810/LAN8810i reference schematics for connection information.
Note 2.3	Ground	VSS	P	Common Ground

Note 2.3 Exposed pad on package bottom ([Figure 2.1](#)).

Table 2.8 72-QFN Pin Assignments

PIN NUM	PIN NAME	PIN NUM	PIN NAME	PIN NUM	PIN NAME	PIN NUM	PIN NAME
1	TCK	19	RXER	37	TXER	55	nRESET
2	TMS	20	CRS	38	TXCLK	56	HPD
3	TDO	21	COL	39	GTCLK	57	TR0N
4	XI	22	RXCLK	40	VDD12CORE	58	TR0P
5	XO	23	VDDVARIO	41	VDDVARIO	59	VDD12A
6	VDDVARIO	24	VDD12CORE	42	ACT_LED	60	TR1N
7	VDD12CORE	25	MACCLK/ MACCLK_SEL	43	1000_LED	61	TR1P
8	RXD0	26	TXD7	44	100_LED/ HPD_MODE	62	VDD12A
9	RXD1	27	TXD6	45	10_LED/ REFCLK_SEL	63	VDD12BIAS
10	RXD2	28	TXD5	46	CONFIG3	64	VDD12PLL
11	RXD3	29	TXD4	47	CONFIG2	65	TR2N
12	RXD4	30	TXD3	48	VDD12CORE	66	TR2P
13	RXD5	31	VDD12CORE	49	VDDVARIO	67	VDD12A
14	VDDVARIO	32	VDDVARIO	50	CONFIG1	68	TR3N
15	VDD12CORE	33	TXD2	51	CONFIG0	69	TR3P
16	RXD6	34	TXD1	52	MDC	70	VDD12A
17	RXD7	35	TXD0	53	MDIO	71	IRQ
18	RXDV	36	TXEN	54	ETHRBIAS	72	TDI
EXPOSED PAD MUST BE CONNECTED TO VSS							

Datasheet

2.1 Buffer Types

Table 2.9 Buffer Types

BUFFER TYPE	DESCRIPTION
VIS	Variable voltage Schmitt-triggered input
VO6	Variable voltage output with 6mA sink and 6mA source
VO8	Variable voltage output with 8mA sink and 8mA source
PU	50uA (typical) internal pull-up. Unless otherwise noted in the pin description, internal pull-ups are always enabled. Note: Internal pull-up resistors prevent unconnected inputs from floating. Do not rely on internal resistors to drive signals external to the device. When connected to a load that must be pulled high, an external resistor must be added.
PD	50uA (typical) internal pull-down. Unless otherwise noted in the pin description, internal pull-downs are always enabled. Note: Internal pull-down resistors prevent unconnected inputs from floating. Do not rely on internal resistors to drive signals external to the device. When connected to a load that must be pulled low, an external resistor must be added.
AI	Analog input
AIO	Analog bi-directional
ICLK	Crystal oscillator input pin
OCLK	Crystal oscillator output pin
P	Power pin

Note: The digital signals are not 5V tolerant. Refer to [Section 5.1, "Absolute Maximum Ratings*,"](#) on [page 82](#) for additional buffer information.

Note: Sink and source capabilities are dependant on the VDDVARIO voltage. Refer to [Section 5.1, "Absolute Maximum Ratings*,"](#) on [page 82](#) for additional information.

Chapter 3 Functional Description

This chapter provides functional descriptions of the various device features. These features have been categorized into the following sections:

- [Auto-negotiation](#)
- [HP Auto-MDIX](#)
- [GMII Interface](#)
- [Serial Management Interface \(SMI\)](#)
- [Interrupt Management](#)
- [Resets](#)
- [Power-Down modes](#)
- [Configuration](#)
- [Miscellaneous Functions](#)
- [Application Diagrams](#)

3.1 Auto-negotiation

The purpose of the auto-negotiation function is to automatically configure the PHY to the optimum link parameters based on the capabilities of its link partner. Auto-negotiation is a mechanism for exchanging configuration information between two link-partners and automatically selecting the highest performance mode of operation supported by both sides. Auto-negotiation is fully defined in clause 28 and clause 40 of the IEEE 802.3 specification.

Once auto-negotiation has completed, information about the resolved link can be passed back to the controller via the integrated [Serial Management Interface \(SMI\)](#). The results of the negotiation process are reflected in the [Speed Indication](#) field of the [PHY Special Control / Status Register](#) as well as the [Auto Negotiation Link Partner Ability Register](#).

The advertised capabilities of the PHY are stored in [Auto Negotiation Advertisement Register](#). The defaults advertised by the device are determined as described in [Section 3.8.1.2.2, "Configuring the Mode of Operation \(CONFIG\[3:2\]\)"](#), on page 31.

The auto-negotiation protocol is a purely physical layer activity and proceeds independently of the MAC controller. When enabled, auto-negotiation is started by the occurrence of one of the following events:

- Hardware reset
- Software reset
- Power-down reset
- Link status down
- Setting the [Restart Auto-Negotiate](#) bit of the [Basic Control Register](#)

On detection of one of these events, the device begins auto-negotiation by transmitting bursts of Fast Link Pulses (FLP). The data transmitted by an FLP burst is known as a "Link Code Word." This exchange of information allows link partners to determine the Highest Common Ability (HCD).

Once a capability match has been determined, the link code words are repeated with the acknowledge bit set. Any difference in the main content of the link code words at this time will cause auto-negotiation to re-start. Auto-negotiation will also re-start if all of the required FLP bursts are not received.

Writing the [100BASE-TX Full Duplex](#), [100BASE-TX](#), [10BASE-T Full Duplex](#), and [10BASE-T](#) bits of the [Auto Negotiation Advertisement Register](#) allows software control of the advertised capabilities.

Datasheet

However, writing the [Auto Negotiation Advertisement Register](#) does not automatically re-start auto-negotiation. The [Restart Auto-Negotiate](#) bit of the [Basic Control Register](#) must be set before the new abilities will be advertised. Auto-negotiation can also be disabled via software by clearing the [Auto-Negotiation Enable](#) bit of the [Basic Control Register](#).

Auto-Negotiation also resolves the Master/Slave clocking relationship between two PHYs for a 1000BASE-T link. Refer to [Section 3.1.4, "Master/Slave," on page 20](#) for additional information.

3.1.1 Restarting Auto-negotiation

Auto-negotiation can be restarted at any time by using the [Restart Auto-Negotiate](#) bit of the [Basic Control Register](#). Auto-negotiation will also re-start if the link is broken at any time. A broken link is caused by signal loss. This may occur because of a cable break, or because of an interruption in the signal transmitted by the Link Partner. Auto-negotiation resumes in an attempt to determine the new link configuration.

If the management entity restarts Auto-negotiation by writing to the [Restart Auto-Negotiate](#) bit, the device will respond by stopping all transmission/receiving operations. Auto-negotiation will restart after approximately 1200 mS. The Link Partner will have also dropped the link and will resume auto-negotiation.

3.1.2 Disabling Auto-negotiation

Auto-negotiation can be disabled via software by clearing the [Auto-Negotiation Enable](#) bit of the [Basic Control Register](#). The device will then force its speed of operation to reflect the information in the [Speed Select\[1\]](#), [Speed Select\[0\]](#), and [Duplex Mode](#) bits of the [Basic Control Register](#). These bits are ignored when auto-negotiation is enabled.

3.1.3 Parallel Detection

If the LAN8810/LAN8810i is connected to a device lacking the ability to auto-negotiate (i.e., no FLPs are detected), it is able to determine the speed of the link based on either 100M MLT-3 symbols or 10M Normal Link Pulses. In this case, the link is presumed to be half-duplex per the IEEE standard. This ability is known as "Parallel Detection". This feature ensures inter operability with legacy link partners.

The Ethernet MAC has access to information regarding parallel detect via the [Auto Negotiation Expansion Register](#). If a link is formed via parallel detection, the [Link Partner Auto-Negotiation Able](#) bit of the [Auto Negotiation Expansion Register](#) is cleared to indicate that the Link Partner is not capable of auto-negotiation. If a fault occurs during parallel detection, the [Parallel Detection Fault](#) bit of this register is set.

The [Auto Negotiation Link Partner Ability Register](#) is updated with information from the link partner which is coded in the received FLPs. If the Link Partner is not auto-negotiation capable, then the [Auto Negotiation Link Partner Ability Register](#) is updated after completion of parallel detection to reflect the speed capability of the Link Partner.

Parallel detect cannot be used to establish Gigabit Ethernet links because echo cancellation and signal recovery on a Gigabit Ethernet link requires resolution of the Master/Slave clock relationship, which requires the exchange of FLPs.

3.1.4 Master/Slave

In 1000BASE-T, one of the two link partner devices must be configured as Master and the other as Slave. The Master device transmits data using the local clock, while the Slave device uses the clock recovered from incoming data.

The Master and Slave assignments are set using the configuration pins as described in [Section 3.8.1.2.2, "Configuring the Mode of Operation \(CONFIG\[3:2\]\)," on page 31](#) or by using the [Master/Slave Manual Config Enable](#) and [Master/Slave Manual Config Value](#) bits of the [Master/Slave](#)

Control Register. If both the link partner and the local device are manually given the same Master/Slave assignment, an error will be indicated in the **Master/Slave Configuration Fault** bit of the **Master/Slave Status Register**.

Depending on the link partner configuration, the manual Master/Slave mode can be resolved to sixteen possible outcomes, as shown in [Table 3.1](#).

Table 3.1 Master/Slave Resolution for 1000BASE-T

LAN8810/LAN8810I ADVERTISEMENT	LINK PARTNER ADVERTISEMENT	LAN8810/LAN8810I RESULT	LINK PARTNER RESULT
Single-Port	Single-Port	M/S resolved by random seed	M/S resolved by random seed
Single-Port	Multi-Port	Slave	Master
Single-Port	Manual Master	Slave	Master
Single-Port	Manual Slave	Master	Slave
Multi-Port	Single-Port	Master	Slave
Multi-Port	Multi-Port	M/S resolved by random seed	M/S resolved by random seed
Multi-Port	Manual Master	Slave	Master
Multi-Port	Manual Slave	Master	Slave
Manual Master	Single-Port	Master	Slave
Manual Master	Multi-Port	Master	Slave
Manual Master	Manual Master	No Link	No Link
Manual Master	Manual Slave	Master	Slave
Manual Slave	Single-Port	Slave	Master
Manual Slave	Multi-Port	Slave	Master
Manual Slave	Manual Master	Slave	Master
Manual Slave	Manual Slave	No Link	No Link

3.1.5 Manual Operation

The device supports a manual (forced) operation for test purposes. In manual operation, the user sets the link speed (10Mbps or 100Mbps) and the duplex state (full or half).

Auto-negotiation must be disabled in order to manually configure the speed and the duplex. This may be accomplished using the configuration pins, as described in [Section 3.8.1.2.2, "Configuring the Mode of Operation \(CONFIG\[3:2\]\)"](#), on page 31, or by using the [Basic Control Register](#) register as described in [Section 3.1.2, "Disabling Auto-negotiation"](#), on page 20. For 10BASE-T and 100BASE-TX, the link state of the device is determined by the [Speed Select\[1\]](#), [Speed Select\[0\]](#), and [Duplex Mode](#) bits of the [Basic Control Register](#). Manual operation at a link speed of 1000Mbps is not supported.

3.1.6 Half vs. Full-Duplex

Half-duplex operation relies on the CSMA/CD (Carrier Sense Multiple Access / Collision Detect) protocol to handle network traffic and collisions. In this mode, the internal carrier sense signal, CRS, responds to both transmit and receive activity. If data is received while the PHY is transmitting, a collision results.

Datasheet

In full-duplex mode, the PHY is able to transmit and receive data simultaneously and collision detection is disabled. In this mode, the internal CRS responds only to receive activity. In 10BASE-T and 100BASE-T mode, CRS is redefined to respond only to received activity. In 1000BASE-T, CRS is disabled.

[Table 3.2](#) describes the behavior of the internal CRS bit under all receive/transmit conditions.

Table 3.2 CRS Behavior

MODE	SPEED	DUPLEX	ACTIVITY	CRS BEHAVIOR (Note 3.1)
Manual	10 Mbps	Half-Duplex	Transmitting	Active
Manual	10 Mbps	Half-Duplex	Receiving	Active
Manual	10 Mbps	Full-Duplex	Transmitting	Low
Manual	10 Mbps	Full-Duplex	Receiving	Active
Manual	100 Mbps	Half-Duplex	Transmitting	Active
Manual	100 Mbps	Half-Duplex	Receiving	Active
Manual	100 Mbps	Full-Duplex	Transmitting	Low
Manual	100 Mbps	Full-Duplex	Receiving	Active
Auto-Negotiation	10 Mbps	Half-Duplex	Transmitting	Active
Auto-Negotiation	10 Mbps	Half-Duplex	Receiving	Active
Auto-Negotiation	10 Mbps	Full-Duplex	Transmitting	Low
Auto-Negotiation	10 Mbps	Full-Duplex	Receiving	Active
Auto-Negotiation	100 Mbps	Half-Duplex	Transmitting	Active
Auto-Negotiation	100 Mbps	Half-Duplex	Receiving	Active
Auto-Negotiation	100 Mbps	Full-Duplex	Transmitting	Low
Auto-Negotiation	100 Mbps	Full-Duplex	Receiving	Active

Note 3.1 The internal CRS signal operates in two modes: Active and Low. When in Active mode, the internal CRS will transition high and low upon line activity, where a high value indicates a carrier has been detected. In Low mode, the internal CRS stays low and does not indicate carrier detection.

3.2 HP Auto-MDIX

HP Auto-MDIX facilitates the use of CAT-5 (100BASE-T) media UTP interconnect cable without consideration of interface wiring scheme. If a user plugs in either a direct connect LAN cable, or a cross-over patch cable, as shown in [Figure 3.1](#), the Auto-MDIX PHY is capable of configuring the twisted pair pins for correct transceiver operation.

The internal logic of the device detects the TX and RX pins of the connecting device. It can automatically re-assign channel 0 and 1 if required to establish a link. In 1000BASE-T mode, it can re-assign channel 2 and 3. Crossover resolution precedes the actual auto-negotiation process that involves exchange of FLPs to advertise capabilities. Automatic MDI/MDIX is described in IEEE 802.3ab Clause 40, section 40.8.2. Since the RX and TX line pairs are interchangeable, special PCB design

considerations are needed to accommodate the symmetrical magnetics and termination of an Auto-MDIX design.

Auto-MDIX is enabled by default, and can be disabled by the [Auto MDIX Disable](#) bit in the [10/100 Mode Control/Status Register](#). When Auto-MDIX is disabled, the TX and RX pins can be configured manually by the [MDI/MDI-X 0:1](#) and [MDI/MDI-X 2:3](#) bits in the [Extended Mode Control/Status Register](#).

The device includes an advanced crossover resolution capability called Semi Crossover. This is an extension to HP Auto-MDIX that corrects for a cable with only two pairs crossed. If Semi Crossover is enabled, after the device has attempted to establish a link with all four signal pairs normal or crossed, it will attempt to establish a link with pairs 2/3 switched and 0/1 straight, and then with pairs 0/1 switched and pairs 2/3 straight. The Semi Crossover is enabled by default, and can be disabled by the [Semi Crossover Enable](#) bit in the [10/100 Mode Control/Status Register](#).

After resolution of crossed pairs is complete, using either HP Auto-MDIX or the Semi Crossover function, the MDI/MDI-X status is reported through the [XOVER Resolution 0:1](#) and [XOVER Resolution 2:3](#) bits of the [User Status 2 Register](#).

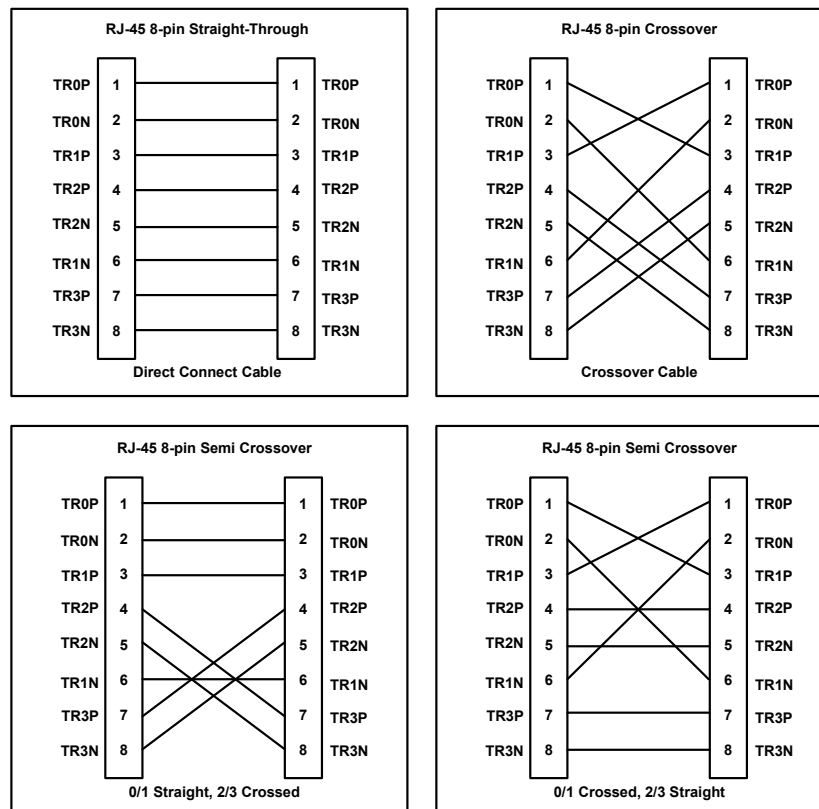

Figure 3.1 Cable Connection Types: Straight-Through, Crossover, Semi Crossover

3.2.1 Required Ethernet Magnetics

The magnetics selected for use with the device should be an Auto-MDIX style magnetic available from several vendors. Refer to SMSC Application Note 8.13 "Suggested Magnetics" for the latest qualified and suggested magnetics. Vendors and part numbers are provided in this application note.

3.3 GMII Interface

The device communicates with an external MAC using the Gigabit Media Independent Interface (GMII). The GMII is compliant with the IEEE 802.3 standard, and provides support for 1000BASE-T, 100BASE-TX, or 10BASE-T operation.

For 1000BASE-T, the MAC generated 125MHz GTXCLK transmit clock is used to synchronize the TXD, TXEN and TXER signals. For 100BASE-TX and 10BASE-T operation, the device generated TXCLK transmit clock is used to synchronize the TXD, TXEN and TXER signals. TXCLK is 25MHz or 2.5MHz for 100BASE-TX and 10BASE-T operation, respectively. TXER and TXEN are both driven by the MAC and indicate a transmit error and valid transmit data, respectively. On the receiver side, the device generated RXCLK is used to synchronize the RXD, RXDV, RXER, COL and CRS signals for all modes of operation.

The GMII provides backwards compatibility with the legacy MII. [Table 3.3, "GMII/MII Signal Mapping"](#) describes which pins are used in each mode.

Table 3.3 GMII/MII Signal Mapping

GMII MODE (IEEE 802.3 CLAUSE 35)	MII MODE (IEEE 802.3 CLAUSE 22)
TXD[3:0]	TXD[3:0]
TXD[7:4]	
TXEN	TXEN
TXER	TXER
TXCLK (10/100Mbps operation)	TXCLK
GTXCLK (1000Mbps operation)	
COL	COL
CRS	CRS
RXD[3:0]	RXD[3:0]
RXD[7:4]	
RXDV	RXDV
RXER	RXER
RXCLK	RXCLK

Timing information for the GMII/MII interface is provided in [Section 5.5, "AC Specifications," on page 87](#). For additional information on the GMII/MII interface, refer to the IEEE 802.3 specification.

3.3.1 MII Isolate Mode

The device may be configured to electrically isolate the GMII pins by setting the [Isolate](#) bit of the [Basic Control Register](#). In this mode, all MAC data interface output pins are HIGH and all MAC data interface input pins are ignored. In this mode, the SMI interface is kept active, allowing the MAC to access the SMI registers and generate interrupts. All MDI operations are halted while in isolate mode.

3.4 Serial Management Interface (SMI)

The Serial Management Interface is used to control the device and obtain its status. This interface supports the standard PHY registers required by Clause 22 of the 802.3 standard, as well as “vendor-specific” registers allowed by the specification. Non-supported registers (such as 11 to 14) will be read as hexadecimal “FFFF”. Device registers are detailed in [Chapter 4, "Register Descriptions,"](#) on [page 43](#).

At the system level, SMI provides 2 signals: MDIO and MDC. The MDC signal is an aperiodic clock provided by the station management controller (SMC). MDIO is a bi-directional data SMI input/output signal that receives serial data (commands) from the controller SMC and sends serial data (status) to the SMC. The minimum time between edges of the MDC is 160 ns. There is no maximum time between edges. The minimum cycle time (time between two consecutive rising or two consecutive falling edges) is 400 ns. These modest timing requirements allow this interface to be easily driven by the I/O port of a microcontroller.

The data on the MDIO line is latched on the rising edge of the MDC. The frame structure and timing of the data is shown in [Figure 3.1](#) and [Figure 3.2](#). The timing relationships of the MDIO signals are further described in [Section 5.5.7, "SMI Timing,"](#) on [page 95](#).

Read Cycle

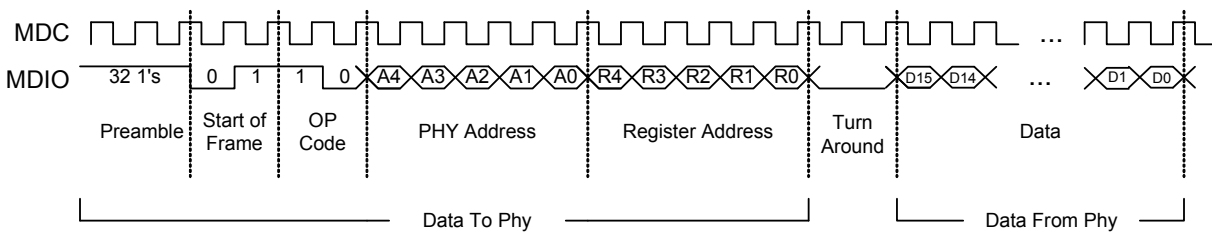

Figure 3.1 MDIO Timing and Frame Structure - READ Cycle

Write Cycle

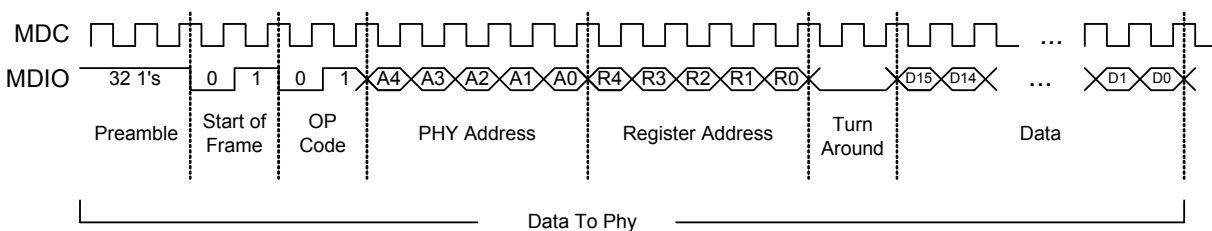

Figure 3.2 MDIO Timing and Frame Structure - WRITE Cycle

3.5 Interrupt Management

The device supports multiple interrupt capabilities which are not a part of the IEEE 802.3 specification. An active low asynchronous interrupt signal may be generated on the IRQ pin when selected events are detected, as configured by the [Interrupt Mask Register](#).

To set an interrupt, the corresponding mask bit in the [Interrupt Mask Register](#) must be set (see [Table 3.4](#)). When the associated event occurs, the IRQ pin will be asserted. When the corresponding event to deassert IRQ is true, the IRQ pin will be deasserted. All interrupts are masked following a reset.

Note: [Table 3.4](#) utilizes register index and bit number referencing in lieu of individual names. For example, “30.10” is used to reference bit 10 (transmitter elastic buffer overflow interrupt enable) of the [Interrupt Mask Register](#) (register index 30).

Table 3.4 Interrupt Management Table

MASK	INTERRUPT SOURCE FLAG		INTERRUPT SOURCE		EVENT TO ASSERT IRQ	EVENT TO DEASSERT IRQ
30.15:11	29.15:11	RESERVED	-NA-	-NA-	-NA-	-NA-
30.10	29.10	Transmitter Elastic Buffer Overflow	-NA-	-NA- (Note 3.3)	Transmitter Elastic Buffer Overflow	Overflow condition resolved
30.9	29.9	Transmitter Elastic Buffer Underflow	-NA-	-NA- (Note 3.3)	Transmitter Elastic Buffer Underflow	Underflow condition resolved
30.8	29.8	Idle Error Count Overflow	10.7:0	Idle Error Count	Idle Error Count Overflow	Reading register 10
30.7	29.7	ENERGYON	17.1	ENERGYON	Rising 17.1 (Note 3.2)	Falling 17.1 or Reading register 29
30.6	29.6	Auto-Negotiation complete	1.5	Auto-Negotiate Complete	Rising 1.5	Falling 1.5 or Reading register 29
30.5	29.5	Remote Fault Detected	1.4	Remote Fault	Rising 1.4	Falling 1.4, or Reading register 1 or Reading register 29
30.4	29.4	Link Down	1.2	Link Status	Falling 1.2	Reading register 1 or Reading register 29
30.3	29.3	RESERVED	-NA-	-NA-	-NA-	-NA-
30.2	29.2	Parallel Detection Fault	6.4	Parallel Detection Fault	Rising 6.4	Falling 6.4 or Reading register 6, or Reading register 29 or Re-AutoNegotiate or Link down
30.1	29.1	Auto-Negotiation Page Received	6.1	Page Received	Rising 6.1	Falling of 6.1 or Reading register 6, or Reading register 29 Re-auto-negotiate, or Link Down.

Note 3.2 The [ENERGYON](#) bit of the [10/100 Mode Control/Status Register](#) (17.1) defaults to “1” after a hardware reset. If no energy is detected before 256mS, the [ENERGYON](#) bit will be cleared. When [ENERGYON](#) is “0” and energy is detected, due to the establishment of a valid link or the PHY auto-negotiation moving past the ability detect state, the [ENERGYON](#) bit will be set and the [INT7](#) bit of the [Interrupt Source Flags Register](#) will assert. If [ENERGYON](#) is set and the energy is removed, the [INT7](#) bit will assert. The [ENERGYON](#) bit will clear 256mS after the interrupt. If the PHY is in manual mode, [INT7](#) will be asserted 256mS after the link is broken. If the PHY is auto-negotiating, [INT7](#) will be asserted 256mS after the PHY returns to the ability detect state (maximum of 1.5S after the link is broken).

To prevent an unexpected assertion of IRQ, the ENERGYON interrupt mask ([INT7_EN](#)) should always be cleared as part of the ENERGYON interrupt service routine.

Note 3.3 The transmitter FIFO depth can be adjusted via the [Transmitter FIFO Depth](#) field of the [Extended Mode Control/Status Register](#) (19.10:9).

3.6 Resets

The device provides the following chip-level reset sources:

- [Hardware Reset \(nRESET\)](#)
- [Software Reset](#)
- [Power-Down Reset](#)

3.6.1 Hardware Reset (nRESET)

A hardware reset will occur when the system reset nRESET input pin is driven low. When nRESET is asserted, it must be held low for the minimum time specified in [Section 5.5.3, "Power-On Reset Timing," on page 89](#) to ensure proper reset to the PHY. Following a hardware reset, the device resets the device registers and relatches the configuration straps and CONFIG[3:0] pins.

Note: A hardware reset (nRESET assertion) is required following power-up. Refer to [Section 5.5.3, "Power-On Reset Timing," on page 89](#) for additional information.

3.6.2 Software Reset

A software reset is initiated by writing a '1' to the [PHY Soft Reset \(RESET\)](#) bit of the [Basic Control Register](#). This self-clearing bit will return to '0' after approximately 256µs, at which time the PHY reset is complete. This reset initializes the logic within the PHY, with the exception of register bits marked as "NASR" (Not Affected by Software Reset).

Following a software reset, the device configuration is reloaded from the register bit values, and not from the configuration straps and CONFIG[3:0] pins. The device does not relatch the hardware configuration settings. For example, if the device is powered up and a configuration strap is changed from its initial power up state, a software reset will not load the new strap setting.

3.6.3 Power-Down Reset

A power-down reset is automatically activated when the device comes out of the power-down mode. During power-down, the registers are not reset. Configuration straps and CONFIG[3:0] pins are not latched as a result of a power-down reset. The power-down reset is internally extended by 256 µs after exiting the power-down mode to allow the PLLs to stabilize before the logic is released from reset. Refer to [Section 3.7, "Power-Down modes," on page 28](#) for details on the various power-down modes.

3.7 Power-Down modes

The device supports 3 power-down modes:

- [General Power-Down](#)
- [Energy Detect Power-Down](#)
- [Hardware Power-Down](#)

3.7.1 General Power-Down

This power-down mode is controlled by the [Power Down](#) bit of the [Basic Control Register](#). In this mode, the entire device is powered-down except for the serial management interface and MACCLK output. The device remains in the general power-down mode while [Power Down](#) is set. When [Power Down](#) is cleared, the device powers up and is automatically reset (via a [Power-Down Reset](#)). Additionally setting the [MACCLKDIS](#) bit of the [Extended Mode Control/Status Register](#) will disable the MACCLK pin output and power-down the PLL. For maximum power savings, auto-negotiation should be disabled before enabling the general power-down mode.

3.7.2 Energy Detect Power-Down

This power-down mode is controlled by the [EDPWRDOWN](#) bit of the [10/100 Mode Control/Status Register](#). In this mode, when no energy is present on the line, nothing is transmitted and the device is powered-down except for the management interface, MACCLK, the SQUELCH circuit and the ENERGYON logic.

The [ENERGYON](#) bit in the [10/100 Mode Control/Status Register](#) is asserted when there is valid energy from the line (100BASE-TX, 10BASE-T, or Auto-Negotiation signals) and the PHY powers-up. It automatically resets itself into the previous state prior to power-down, and stays in active mode as long as energy exists on the line. If the ENERGYON interrupt is enabled ([INT7_EN](#) of the [Interrupt Mask Register](#)), IRQ is asserted.

Note: The first and possibly second packet to activate ENERGYON may be lost.

3.7.3 Hardware Power-Down

This power-down mode is controlled by the HPD pin. In this mode, the entire device is powered-down except for the serial management interface. The [HPD_MODE](#) configuration strap selects whether the PLL will be shut down when in hardware power-down mode. To exit the hardware power-down mode, the HPD pin must be deasserted, followed by the deassertion of the [Power Down](#) bit in the [Basic Control Register](#). If the hardware power-down mode is set to shut down the PLL, a software reset must also be issued.

Note: The device will wake-up in the hardware power-down mode if the HPD pin is asserted during hardware reset.

Note: For additional information on the [HPD_MODE](#) configuration strap, refer to [Section 3.8.1.1, "Configuration Straps,"](#) on page 29.

3.8 Configuration

The device mode of operation may be controlled by hardware and software (register-selectable) configuration options. The initial configuration may be selected in hardware as described in [Section 3.8.1](#). In addition, register-selectable software configuration options may be used to further define the functionality of the transceiver as described in [Section 3.8.2](#). The device supports both IEEE 802.3-2005 compliant and vendor-specific register functions.

3.8.1 Hardware Configuration

Hardware configuration is controlled via multiple configuration straps and the CONFIG[3:0] configuration pins. These items are detailed in the following sub-sections.

3.8.1.1 Configuration Straps

Configuration straps are multi-function pins that are driven as outputs during normal operation. During a [Hardware Reset \(nRESET\)](#), these outputs are tri-stated. The high or low state of the signal is latched following de-assertion of the reset and is used to determine the default configuration of a particular feature. [Table 3.5](#) details the configuration straps. Configuration straps are also listed as part of [Chapter 2, "Pin Description and Configuration," on page 10](#) with underlined names.

Configuration straps include internal resistors in order to prevent the signal from floating when unconnected. If a particular configuration strap is connected to a load, an external pull-up or pull-down should be used to augment the internal resistor to ensure that it reaches the required voltage level prior to latching. The internal resistor can also be overridden by the addition of an external resistor.

Note: The system designer must guarantee that configuration straps meet the timing requirements specified in [Section 5.5.3, "Power-On Reset Timing," on page 89](#). If configuration straps are not at the correct voltage level prior to being latched, the device may capture incorrect strap values.

Note: Configuration straps must never be driven as inputs. If required, configuration straps can be augmented, or overridden with external resistors.

Table 3.5 Configuration Straps

CONFIGURATION STRAP	DESCRIPTION	LOGIC 0 (PD)	LOGIC 1 (PU)
<u>MACCLK_SEL</u>	Selects the MACCLK output clock frequency	125MHz (Default)	25MHz
<u>REFCLK_SEL</u>	Selects the reference clock frequency	25MHz (Default)	125MHz
<u>HPD_MODE</u>	Selects the hardware power-down (HPD) mode	HPD with PLL disabled (Default)	HPD with PLL enabled

3.8.1.2 CONFIG[3:0] Configuration Pins

The device provides 4 dedicated configuration pins, CONFIG[3:0], which are used to select the default SMI address and mode of operation. The CONFIG[3:0] configuration pins differ from configuration straps in that they are single-purpose pins and have different latch timing requirements. The high or low states of the CONFIG[3:0] pins are latched following deassertion of a [Hardware Reset \(nRESET\)](#). Refer to [Section 5.5.3, "Power-On Reset Timing," on page 89](#) for additional CONFIG[3:0] timing information.

Each CONFIG[3:0] configuration pin can be connected in one of four ways. The Configuration Pin Value (CPV) represented by each connection option is shown in [Table 3.6](#).

Table 3.6 Hardware Connection Determines Configuration Pin Value (CPV)

CONFIG[X] CONNECTS TO:	VALUE
GND	CPV(0)
100_LED	CPV(1)
1000_LED	CPV(2)
VDD	CPV(3)

Using the CPV nomenclature for each CONFIG[3:0] pin, [Section 3.8.1.2.1](#) describes how to configure the SMI address and [Section 3.8.1.2.2](#) describes how to configure the initial mode of operation.

Note: The HPD pin is also a dedicated configuration pin. HPD forces the entire device to power down except for the management interface. The Hardware Power-Down mode is described in [Section 3.7.3, "Hardware Power-Down," on page 28.](#)

3.8.1.2.1 CONFIGURING THE SMI ADDRESS (CONFIG[1:0])

The SMI address may be configured via hardware to any value between 0 and 7. If an address greater than 7 is required, the user can configure the PHY address using [Software Configuration](#) via the [PHYADD\[4:0\]](#) field of the [10/100 Special Modes Register](#) (after SMI communication at an address is established).

The CONFIG1 pin is used to configure both the SMI address and the value of the [Pause Operation \(PAUSE\)](#) bit in the [Auto Negotiation Advertisement Register](#). The user must first determine the desired PAUSE value. The configuration pin values for CONFIG1 and CONFIG0 should then be selected using [Table 3.7](#) (PAUSE=0) or [Table 3.8](#) (PAUSE=1), respectively.

Table 3.7 SMI Address Configuration with PAUSE=0

PHYADD[2:0]	CONFIG1	CONFIG0
000	CPV(0)	CPV(0)
001	CPV(0)	CPV(1)
010	CPV(0)	CPV(2)
011	CPV(0)	CPV(3)
100	CPV(1)	CPV(0)
101	CPV(1)	CPV(1)
110	CPV(1)	CPV(2)
111	CPV(1)	CPV(3)

Table 3.8 SMI Address Configuration with PAUSE=1

PHYADD[2:0]	CONFIG1	CONFIG0
000	CPV(2)	CPV(0)
001	CPV(2)	CPV(1)
010	CPV(2)	CPV(2)
011	CPV(2)	CPV(3)
100	CPV(3)	CPV(0)
101	CPV(3)	CPV(1)
110	CPV(3)	CPV(2)
111	CPV(3)	CPV(3)

3.8.1.2.2 CONFIGURING THE MODE OF OPERATION (CONFIG[3:2])

This section describes the initial modes of operation that are available using the CONFIG[3:2] configuration pins. The user may configure additional modes using [Software Configuration](#) when the CONFIG[3:2] options do not include the desired mode.

The CONFIG3 pin is used to configure the values of the MOD field (19.15:11) and the MACCLKDIS bit (19.3) of the [Extended Mode Control/Status Register](#). To select a default configuration mode via the CONFIG[3:0] pins, the user must first select whether to enable or disable the MACCLK (MACCLKDIS bit). The configuration pin values for CONFIG3 and CONFIG2 should be selected using [Table 3.9](#) to set MACCLKDIS=0, or [Table 3.10](#) to set MACCLKDIS=1. These tables also detail how the MOD field of the [Extended Mode Control/Status Register](#) will be configured.

[Section 3.8.1.2.3](#) describes how the MOD field controls other configuration bits in the device. When a soft reset is issued via the PHY Soft Reset (RESET) bit of the [Basic Control Register](#), configuration is controlled by the register bit values and the CONFIG[3:0] pins have no affect. Likewise, changing the MOD field of the [Extended Mode Control/Status Register](#) bits does not change the configuration of the device in this case.

Note: [Table 3.9](#) and [Table 3.10](#) utilize register index and bit number referencing in lieu of individual names.

Datasheet

Table 3.9 Configuring the Mode of Operation with MACCLKDIS=0

MODE DEFINITIONS	CONFIG3	CONFIG2	REG 19 [15:11]
10BASE-T Half Duplex. Auto-negotiation disabled.	CPV(0)	CPV(0)	00000
10BASE-T Full Duplex. Auto-negotiation disabled.	CPV(0)	CPV(1)	00001
100BASE-TX Half Duplex. Auto-negotiation disabled. CRS is active during Transmit & Receive.	CPV(0)	CPV(2)	00010
100BASE-TX Half Duplex. Auto-negotiation disabled. CRS is active during Receive.	CPV(0)	CPV(3)	00011
All mode capable (10/100/1000). Auto-negotiation enabled. Auto master/slave resolution single port.	CPV(1)	CPV(0)	00111
10BASE-T/100BASE-TX capable. Auto-negotiation enabled. CRS is active during Transmit & Receive.	CPV(1)	CPV(1)	00100
All mode capable (10/100/1000). Auto-negotiation enabled. Manual master/slave resolution slave port.	CPV(1)	CPV(2)	01001
All capable (10/100/1000). Auto-negotiation enabled. Manual master/slave resolution master port.	CPV(1)	CPV(3)	01010

Table 3.10 Configuring the Mode of Operation with MACCLKDIS=1

MODE DEFINITIONS	CONFIG3	CONFIG2	REG 19 [15:11]
10BASE-T Half Duplex. Auto-negotiation disabled.	CPV(2)	CPV(0)	00000
10BASE-T Full Duplex. Auto-negotiation disabled.	CPV(2)	CPV(1)	00001
100TX Half Duplex. Auto-negotiation disabled. CRS is active during Transmit & Receive.	CPV(2)	CPV(2)	00010
100BASE-TX Half Duplex. Auto-negotiation disabled. CRS is active during Receive.	CPV(2)	CPV(3)	00011
All mode capable (10/100/1000). Auto-negotiation enabled. Auto master/slave resolution single port.	CPV(3)	CPV(0)	00111
10BASE-T/100BASE-TX capable. Auto-negotiation enabled. CRS is active during Transmit & Receive.	CPV(3)	CPV(1)	00100
All mode capable (10/100/1000). Auto-negotiation enabled. Manual master/slave resolution slave port.	CPV(3)	CPV(2)	01001
All mode capable (10/100/1000). Auto-negotiation enabled. Manual master/slave resolution master port.	CPV(3)	CPV(3)	01010

3.8.1.2.3 CONFIGURATION BITS IMPACTED BY THE MODE OF OPERATION

Immediately after a reset, the **MOD** field of the [Extended Mode Control/Status Register](#) will be set dependent on the configuration pin values of the CONFIG3 and CONFIG2 pins, as described in [Section 3.8.1.2.2](#). [Table 3.11](#) details how the **MOD** field effects other device configuration register bits.

Note: [Table 3.11](#) utilizes register index and bit number referencing in lieu of individual names.

Table 3.11 Register Bits Impacted by the Mode of Operation (MOD)

REG 19 [15:11]	MODE DEFINITIONS	REG 0 [13,12,8,6]	REG 4 [8,7,6,5]	REG 9 [12,11,10,9,8]
00000	10BASE-T Half Duplex. Auto-negotiation disabled.	0000	XXXX	XXX00
00001	10BASE-T Full Duplex. Auto-negotiation disabled.	0010	XXXX	XXX00
00010	100BASE-TX Half Duplex. Auto-negotiation disabled. CRS is active during Transmit & Receive.	1000	XXXX	XXX00
00011	100BASE-TX Full Duplex. Auto-negotiation disabled. CRS is active during Receive.	1010	XXXX	XXX00
00100	100BASE-TX Half Duplex. Auto-negotiation enabled. CRS is active during Transmit & Receive.	1100	0100	XXX00
00101	RESERVED	-	-	-
00110	RESERVED	-	-	-
00111	All capable. Auto-negotiation enabled. Auto master/slave resolution single port.	01X1	1111	00011
01000	RESERVED	-	-	-
01001	All capable. Auto-negotiation enabled. Manual master/slave resolution slave port.	01X1	1111	10011
01010	All capable. Auto-negotiation enabled. Manual master/slave resolution master port.	01X1	1111	11111
01011 - 11111	RESERVED	-	-	-

3.8.2 Software Configuration

The Serial Management Interface (SMI) allows for the configuration and control of multiple transceivers. Several 16-bit status and control registers are accessible through the management interface pins MDC and MDIO for 10/100/1000Mbps operation. The device implements all the required MII registers and optional registers as described in [Chapter 4, "Register Descriptions," on page 43](#). Configuring the SMI address is described in [Section 3.8.1.2.1](#). Refer to [Section 3.4, "Serial Management Interface \(SMI\)," on page 25](#) for additional information on the SMI.

Datasheet

3.9 Miscellaneous Functions

3.9.1 LEDs

The device provides the following LED signals to enable visual indication of status:

- 1000_LED
- 100_LED
- 10_LED
- ACT_LED

In all modes, the Full Duplex LED (ACT_LED) is driven immediately after auto-negotiation has resolved the duplex state and before the link is established. The Speed LEDs (1000_LED, 100_LED, 10_LED) are driven after a link is established. Three LED modes of operation are available:

- LED Mode 1 ([Table 3.12](#))
- LED Mode 2 ([Table 3.13](#))
- LED Mode 3 (Default Mode - [Table 3.14](#))

The LED mode is configured via the [LED_MODE\[1:0\]](#) field of the [Extended Mode Control/Status Register](#). The functional operation of the LEDs in each mode is described in [Table 3.12](#), [Table 3.13](#) and [Table 3.14](#).

Note: LED Mode 3 is the default mode of operation and requires four LEDs for full operation.

Note: LED Modes 1 and 2 require two dual LED packages (two LEDs in each package). LED Mode 2 provides collision detection, while LED Mode 1 does not.

Table 3.12 LED Mode 1 Operation - LED_MODE[1:0]=01b

LED	STATUS	DESCRIPTION
100_LED	On Color1	100BASE-T link
1000_LED	On Color2	1000BASE-T link
100_LED & 1000_LED	On Color3	10BASE-T link
10_LED	On Color1 Note 3.4	Link operates at full duplex
ACT_LED	On Color2	Transmit/receive activity
10_LED & ACT_LED	Off	Half duplex, no activity
	On Color1	Full duplex, no activity
	Off/Color2	Half duplex, transmit/receive activity
	Color1/Color2	Full duplex, transmit/receive activity

Note 3.4 Activity will cause duplex LED color to blink.

Table 3.13 LED Mode 2 Operation - LED_MODE[1:0]=10b

LED	STATUS	DESCRIPTION
100_LED	On Color1	1000BASE-T link
1000_LED	On Color2	100BASE-T link
100_LED & 1000_LED	On Color3	10BASE-T link
10_LED	On Color1 Note 3.5	Link operates at full duplex
ACT_LED	On Color2	Transmit/receive activity
10_LED & ACT_LED	On Color3	Collision
	Off	Half duplex, no activity
	On Color1	Full duplex, no activity
	Off/Color2	Half duplex, transmit/receive activity
	Color1/Color2	Full duplex, transmit/receive activity

Note 3.5 Activity will cause duplex LED color to blink.

Table 3.14 LED Mode 3 Operation - LED_MODE[1:0]=11b

LED	STATUS	DESCRIPTION
1000_LED	On	1000BASE-T link
	Blinking	Transmit/receive activity
100_LED	On	100BASE-T link
	Blinking	Transmit/receive activity
10_LED	On	10BASE-T link
	Blinking	Transmit/receive activity
ACT_LED	On	Link operates at full duplex
	Off	Link operates at half duplex

3.9.2 Variable Voltage I/O

The device's digital I/O pins are variable voltage, allowing them to take advantage of low power savings from shrinking technologies. These pins can operate at +2.5V or 3.3V. The applied I/O voltage must maintain its value within the tolerances specified in [Chapter 5, "Operational Characteristics"](#). Varying the voltage up or down after the transceiver has completely powered-on can cause errors in the transceiver operation. Refer to [Chapter 5, "Operational Characteristics," on page 82](#) for additional information.

Datasheet

3.9.3 Isolate Mode

The device data paths may be electrically isolated from the GMII interface by setting the [Isolate](#) bit of the [Basic Control Register](#) to "1". In isolation mode, the transceiver does not respond to the TXD, TXEN and TXER inputs, but does respond to management transactions.

Isolation provides a means for multiple transceivers to be connected to the same GMII interface without contention. By default, the transceiver is not isolated (on power-up, [Isolate](#)=0).

3.9.4 Carrier Sense

The carrier sense signal is output on CRS. Carrier sense operation is defined in the IEEE 802.3u standard. The PHY asserts carrier sense based only on receive activity whenever the PHY is either in repeater mode or full-duplex mode. Otherwise, the PHY asserts carrier sense based on either transmit or receive activity.

The carrier sense logic uses the encoded, unscrambled data to determine carrier activity status. It activates carrier sense with the detection of 2 non-contiguous zeros within any 10 bit span. Carrier sense terminates if a span of 10 consecutive ones is detected before a [/J/K/](#) Start-of Stream Delimiter pair. If an [SSD](#) pair is detected, carrier sense is asserted until either [/T/R/](#) End-of-Stream Delimiter pair or a pair of IDLE symbols is detected. Carrier is negated after the [/T/](#) symbol or the first IDLE. If [/T/](#) is not followed by [/R/](#), then carrier is maintained. Carrier is treated similarly for IDLE followed by some non-IDLE symbol.

3.9.5 Collision Detect

A collision is the occurrence of simultaneous transmit and receive operations. The COL output is asserted to indicate that a collision has been detected. COL remains active for the duration of the collision. COL is changed asynchronously to both RXCLK and TXCLK. A collision can only occur in half-duplex mode. The COL output becomes inactive during full duplex mode.

COL may be tested by setting the [Collision Test](#) bit of the [Basic Control Register](#). This enables the collision test. COL will be asserted within 512 bit times of TXEN rising and will be de-asserted within 4 bit times of TXEN falling.

In 10BASE-T mode, COL pulses for approximately 10 bit times (1us), 2us after each transmitted packet (de-assertion of TXEN). This serves as the Signal Quality Error (SQE) signal and indicates that the transmission was successful.

3.9.6 Link Integrity

This section details the establishment, maintenance and removal of links between the device and a link partner in 1000BASE-T, 100BASE-TX and 10BASE-T modes. Link status is reported in the [Link Status](#) bit of the [Basic Status Register](#). The link status is also used to drive the device LEDs as described in [Section 3.9.1, "LEDs," on page 34](#).

3.9.6.1 Establishing and Maintaining a Link

Once a link state is determined via auto-negotiation, parallel detection, or forced operation, the device and the link partner establish a link.

The completion of the auto-negotiation process is reported via the [Auto-Negotiate Complete](#) bit of the [Basic Status Register](#) and issues an interrupt as described in [Section 3.5, "Interrupt Management," on page 26](#). The speed of the link is reported in the [Speed Indication](#) field of the [PHY Special Control / Status Register](#). The speed is also reported on the LED pins for any link.

Failure to complete the auto-negotiation process is reported through the following status bits:

- **Parallel Detection Fault** reported in the [Auto Negotiation Expansion Register](#) while operating in 10BASE-T or 100BASE-TX modes.
- **Master/Slave Configuration Fault** reported in the [Master/Slave Status Register](#) while operating in 1000BASE-T mode.

A fault occurs if the Master/Slave configuration conditions do not allow master/slave resolution, as defined in the [Master/Slave Manual Config Enable](#) and [Master/Slave Manual Config Value](#) bits in the [Master/Slave Control Register](#) of the local and remote link partners.

3.9.6.2 1000BASE-T

For 1000BASE-T links, the device and its link partner enter a training phase after completion of the auto-negotiation process. The links exchange idle symbols and use the information obtained from receiving this signal to set their adaptive filter coefficients.

These coefficients are used in the receiver to equalize the incoming signal, as well as eliminate signal impairments such as echo and cross-talk. Each side indicates completion of the training phase to its link partner by changing the encoding of the idle-symbols it transmits.

The link is established after both sides indicate completion of the training phase. Each side continues to send idle symbols whenever it has no data to transmit. The link is maintained as long as valid idle, data, or carrier extension symbols are received.

Status of both local and remote receivers is reported in the [Local Receiver Status](#) and [Remote Receiver Status](#) bits of the [Master/Slave Status Register](#).

The device also provides an advanced Auto Link Breaker feature (only for 1000BASE-T links). Using this feature, the link can be taken down if the bit error rate (BER) exceeds the threshold defined in [Link Break Threshold](#) field of the [Link Control Register](#). The error counting occurs during the idle time for a period commensurate with the specified BER. The Auto Link Breaker feature is enabled via the [Link Break Enable](#) bit of the [Link Control Register](#).

3.9.6.3 100BASE-TX

For 100BASE-TX links, the device and its link partner begin transmitting idle symbols after completion of the auto-negotiation process. Each side continues sending idle symbols whenever it has no data to transmit. The link is maintained as long as valid idle symbols or data are received.

3.9.6.4 10BASE-T

For 10BASE-T links, the device and its link partner begin exchanging normal link pulses (NLPs) after completion of the auto-negotiation process. The device transmits an NLP every 16ms and expects to receive an NLP every 8 to 24ms. A link is maintained as long as NLPs are received.

3.9.6.5 Taking Down a Link

The device takes down an established link when the required conditions are no longer met. When a link is down, data transmission stops. For 10BASE-T links, the link is taken down after NLPs are no longer received. For 100BASE-TX and 1000BASE-T links, the link is taken down after valid idle codes are no longer received.

After a link is down, the device does the following:

- If auto-negotiation is enabled, the device re-enters the auto-negotiation phase and begins transmitting FLPs
- If auto-negotiation is not enabled, the device transmits NLPs in 10BASE-T mode, and MLT-3s in 100BASE-TX mode.

Datasheet

3.9.7 Speed Optimizer

The Speed Optimize function is designed to resolve the issue of using auto-negotiation to establish a link on impaired cable plants.

Examples of impaired cable plants for 1000BASE-T (Gigabit) connections include:

- Channel 2 twisted pair cable plant is broken
- Channel 3 twisted pair cable plant is broken
- Channel 2 and 3 twisted pair cable plants are broken
- Cable plant is too long

Examples of impaired cable plants for 100BASE-TX connections include:

- Cable plant is too long
- Using wrong cable plant (such as CAT-3)

The Speed Optimize function requires the MAC to support 1000/100/10 Mbps speeds, 1000/100 Mbps speeds, 1000/10 Mbps or 100/10 Mbps speeds.

If a link fails to establish after the link partners go through auto-negotiation several times at the HCD (Highest Common Denominator), the device advertises the next highest-allowable speed (as set in the [Auto Negotiation Advertisement Register](#)) and restarts auto-negotiation with the new speed.

When 1000BASE-T is advertised, the Speed Optimize function can change its advertised speed from 1000BASE-T to 100BASE-TX and from 100BASE-TX to 10BASE-T. When 100BASE-TX is advertised, the Speed Optimize function can change its advertised speed from 100BASE-TX to 10BASE-T. If a previous link has used the Speed Optimize function to establish a link, when the link goes down, the device begins advertising with all capable speeds.

The Speed Optimize function resets itself to advertise HCD/all speed capabilities after any of the following occurrences:

- Hardware reset
- Software reset
- While link partners exchange link pulses through the Speed Optimize process, the device does not receive link pulses for a period of few seconds
- After an established link goes down

The Speed Optimize function is enabled via [Speed Optimize Enable](#) bit in the [10/100 Mode Control/Status Register](#). When a link (with a speed slower than HCD) is being established through the Speed Optimize process, it is reported via the [Speed Optimize Status](#) bit in the [User Status 2 Register](#).

3.9.8 Loopback Operation

The local loopback mode is enabled by setting the [Loopback](#) bit of the [Basic Control Register](#). In this mode, the scrambled transmit data (output of the scrambler) is looped into the receive logic (input of the descrambler). This mode is useful as a board diagnostic and serves as a quick functional verification of the device. The COL signal will be inactive in this mode, unless the [Collision Test](#) bit of the [Basic Control Register](#) is set.

Note: During transmission in local loopback mode, nothing is transmitted to the line and the transmitters are powered down.

3.9.9 IEEE 1149.1 (JTAG) Boundary Scan

The device includes an integrated JTAG boundary-scan test port for board-level testing. The interface consists of four pins (TDO, TDI, TCK and TMS) and includes a state machine, data register array, and an instruction register. The JTAG pins are described in [Table 2.5, "JTAG Pins," on page 15](#). The JTAG interface conforms to the IEEE Standard 1149.1 - *1990 Standard Test Access Port (TAP) and Boundary-Scan Architecture*.

All input and output data is synchronous to the TCK test clock input. TAP input signals TMS and TDI are clocked into the test logic on the rising edge of TCK, while the output signal TDO is clocked on the falling edge.

The JTAG logic is reset via a hardware reset or when the TMS and TDI pins are high for five TCK periods.

The implemented IEEE 1149.1 instructions and their op codes are shown in [Table 3.15](#).

Table 3.15 IEEE 1149.1 Op Codes

INSTRUCTION	OP CODE	COMMENT
Bypass	111	Mandatory Instruction
Sample/Preload	010	Mandatory Instruction
EXTEST	000	Mandatory Instruction
Clamp	011	Optional Instruction
HIGHZ	100	Optional Instruction
IDCODE	001	Optional Instruction

Note: All digital I/O pins support IEEE 1149.1 operation. Analog pins and the XO pin do not support IEEE 1149.1 operation.

3.9.10 Advanced Features

The device implements several advanced features to enhance manageability of the Ethernet link. These features are detailed in the following sub-sections.

3.9.10.1 Crossover Indicators

The device reports crossed channels in the [XOVER Resolution 0:1](#) and [XOVER Resolution 2:3](#) fields of the [User Status 2 Register](#). This feature is useful for trouble-shooting problems during network installation.

3.9.10.2 Polarity Inversion Indicators

The device automatically detects and corrects inverted signal polarity. This is reported in the polarity inversion bits ([POLARITY_INV_3](#), [POLARITY_INV_2](#), [POLARITY_INV_1](#) and [POLARITY_INV_0](#)) of the [User Status 1 Register](#).

The polarity inversion bit for Channel 1 ([POLARITY_INV_1](#)) is valid after auto-negotiation is complete as indicated by the [Auto-Negotiate Complete](#) bit of the [Basic Status Register](#). The polarity inversion bits for Channels 0, 2 and 3 ([POLARITY_INV_0](#), [POLARITY_INV_2](#), [POLARITY_INV_3](#)) are valid only after the link is up as indicated by the [Link Status](#) bit of the [Basic Status Register](#).

Datasheet**3.9.10.3 Receive Error-Free Packets Counter**

The quality of a link can be monitored by using the Receive Error-Free Packets Counter. The device counts the number of good packets received and reports a 48-bit value across 3 advanced registers: [Receive Error-Free Packets Counter Low Register](#), [Receive Error-Free Packets Counter Mid Register](#), and [Receive Error-Free Packets Counter High Register](#). The [Receive Error-Free Packets Counter Low Register](#) latches the two other related counter registers and must always be read first. The [Receive Error-Free Packets Counter High Register](#) register must be read last, and will automatically clear the counter.

3.9.10.4 CRC Error Counter

This 48-bit counter counts the number of CRC errors detected. It's value can be read across 3 advanced registers: [CRC Error Counter Low Register](#), [CRC Error Counter Mid Register](#), and [CRC Error Counter High Register](#). The [CRC Error Counter Low Register](#) latches the two other related counter registers and must always be read first. The [CRC Error Counter High Register](#) must be read last, and will automatically clear the counter.

3.9.10.5 Receive Error During Data Counter

This 16-bit counter counts the number of errors that occurred while data was being received. The value is read from the [Receive Error During Data Counter Register](#).

3.9.10.6 Receive Error During Idle Counter

This 16-bit counter counts the number of errors that occurred during idle. The value is read from the [Receive Error During Idle Counter Register](#) register.

3.9.10.7 Transmitted Packets Counter

This 48-bit counter counts the number of packets that were transmitted. It's value can be read across 3 advanced registers: [Transmit Packet Counter Low Register](#), [Transmit Packet Counter Mid Register](#), and [Transmit Packet Counter High Register](#). The [Transmit Packet Counter Low Register](#) latches the two other related counter registers and must always be read first. The [Transmit Packet Counter High Register](#) must be read last, and it will automatically clear the counter.

3.10 Application Diagrams

This section provides typical application diagrams for the following:

- Simplified Application Diagram
- Power Supply & Twisted Pair Interface Diagram

3.10.1 Simplified Application Diagram

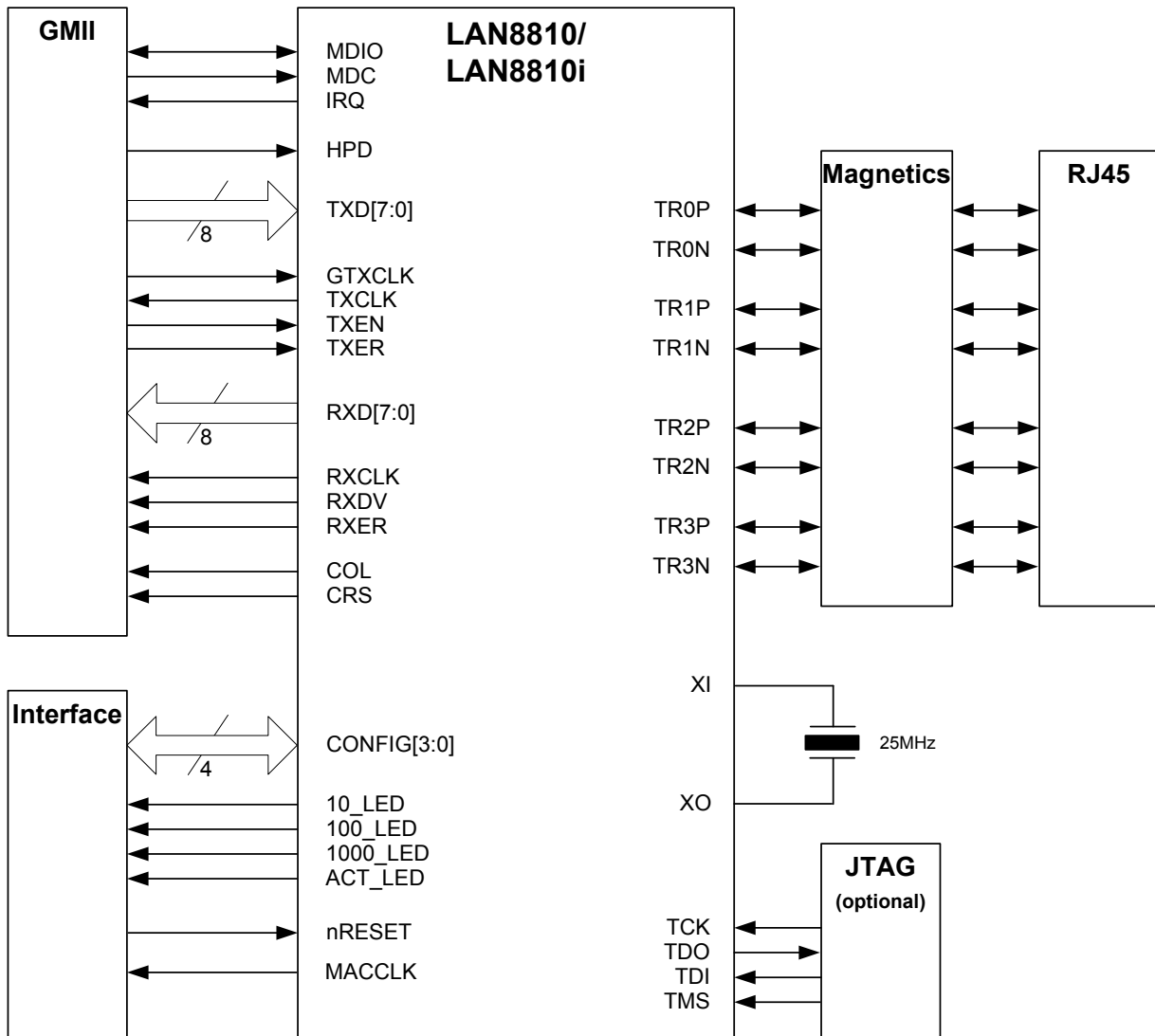

Figure 3.1 Simplified Application Diagram

3.10.2 Power Supply & Twisted Pair Interface Diagram

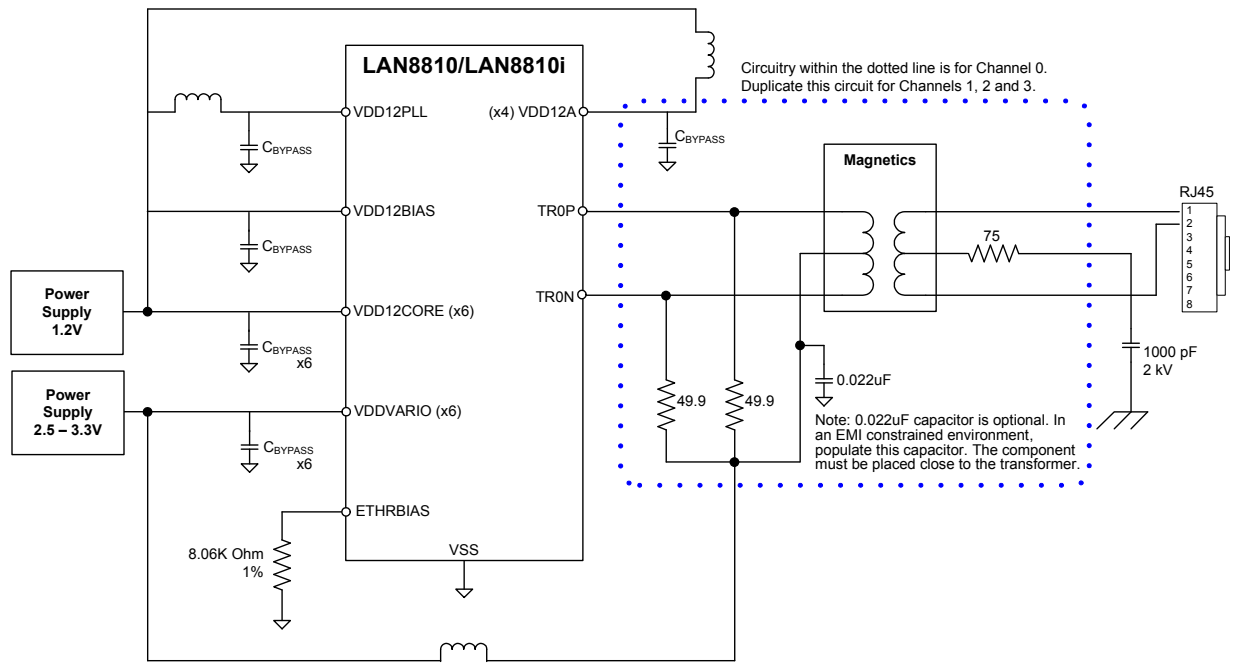

Figure 3.2 Power Supply & Twisted Pair Interface Diagram

Chapter 4 Register Descriptions

This chapter describes the various control and status registers (CSR's). All registers follow the IEEE 802.3 (clause 22.2.4) management register set. All functionality and bit definitions comply with these standards. The IEEE 802.3 specified register index (in decimal) is included with each register definition, allowing for addressing of these registers via the Serial Management Interface (SMI) protocol.

The device registers are categorized into following groups:

- Primary PHY Registers
- Advanced PHY Registers

4.1 Register Nomenclature

Table 4.1 describes the register bit attributes used throughout this document.

Table 4.1 Register Bit Types

REGISTER BIT TYPE NOTATION	REGISTER BIT DESCRIPTION
R	Read: A register or bit with this attribute can be read.
W	Write: A register or bit with this attribute can be written.
RO	Read only: Read only. Writes have no effect.
WO	Write only: If a register or bit is write-only, reads will return unspecified data.
WC	Write One to Clear: writing a one clears the value. Writing a zero has no effect.
WAC	Write Anything to Clear: writing anything clears the value.
RC	Read to Clear: Contents is cleared after the read. Writes have no effect.
LL	Latch Low: Clear on read of register.
LH	Latch High: Clear on read of register.
SC	Self-Clearing: Contents is self-cleared after the being set. Writes of zero have no effect. Contents can be read.
RO/LH	Read Only, Latch High: This mode is used by the Ethernet PHY registers. Bits with this attribute will stay high until the bit is read. After it a read, the bit will remain high, but will change to low if the condition that caused the bit to go high is removed. If the bit has not been read the bit will remain high regardless of if its cause has been removed.
NASR	Not Affected by Software Reset: The state of NASR bits does not change on assertion of a software reset.
X	Either a 1 or 0.
RESERVED	Reserved Field: Reserved fields must be written with zeros, unless otherwise indicated, to ensure future compatibility. The value of reserved bits is not guaranteed on a read.

Many of these register bit notations can be combined. Some examples of this are shown below:

- **R/W:** Can be written. Will return current setting on a read.
- **R/WAC:** Will return current setting on a read. Writing anything clears the bit.

Datasheet

4.2 Primary PHY Registers

The primary PHY registers are accessed via the SMI bus. An index is used to access individual primary registers. Primary PHY register indexes are shown in [Table 4.2, "PHY Control and Status Registers"](#). Additional read-only advanced registers are indirectly accessible via the [Advanced Register Address Port](#) and [Advanced Register Read Data Port](#). [Section 4.3, "Advanced PHY Registers,"](#) on page 68 provides detailed information regarding the advanced registers.

Note: All unlisted register index values are not supported and should not be addressed.

Note: The NASR (Not Affected by Software Reset) designation is only applicable when the [PHY Soft Reset \(RESET\)](#) bit of the [Basic Control Register](#) is set.

Table 4.2 PHY Control and Status Registers

INDEX (IN DECIMAL)	REGISTER NAME
0	Basic Control Register
1	Basic Status Register
2	PHY Identifier 1 Register
3	PHY Identifier 2 Register
4	Auto Negotiation Advertisement Register
5	Auto Negotiation Link Partner Ability Register
6	Auto Negotiation Expansion Register
7	Auto Negotiation Next Page TX Register
8	Auto Negotiation Next Page RX Register
9	Master/Slave Control Register
10	Master/Slave Status Register
15	Extended Status Register
16	Link Control Register
17	10/100 Mode Control/Status Register
18	10/100 Special Modes Register
19	Extended Mode Control/Status Register
20	Advanced Register Address Port
21	Advanced Register Read Data Port
27	Control / Status Indications Register
29	Interrupt Source Flags Register
30	Interrupt Mask Register
31	PHY Special Control / Status Register

4.2.1 Basic Control Register

Index (In Decimal): 0

Size: 16 bits

BITS	DESCRIPTION	TYPE	DEFAULT
15	PHY Soft Reset (RESET) 1 = PHY software reset. This bit is self-clearing. When setting this bit, do not set other bits in this register. The configuration is set from the register bit values as described in Section 3.6.2, "Software Reset," on page 27 . Note: The PHY will be in the normal mode after a PHY software reset.	R/W SC	0b
14	Loopback 0 = normal operation 1 = loopback mode	R/W	0b
13	Speed Select[0] Together with Speed Select[1] , sets speed per the following table: <u>[Speed Select1][Speed Select 0]</u> 00 = 10Mbps 01 = 100Mbps 10 = 1000Mbps 11 = Reserved Note: Ignored if the Auto-Negotiation Enable bit of this register is 1.	R/W	Note 4.1
12	Auto-Negotiation Enable 0 = disable auto-negotiate process 1 = enable auto-negotiate process (overrides the Speed Select[0] , Speed Select[1] , and Duplex Mode bits of this register)	R/W	Note 4.1
11	Power Down 0 = normal operation 1 = General power down mode Note: Auto-Negotiation Enable must be cleared before setting this bit.	R/W	0b
10	Isolate 0 = normal operation 1 = electrical isolation of PHY from GMII	R/W	0b
9	Restart Auto-Negotiate 0 = normal operation 1 = restart auto-negotiate process Note: Bit is self-clearing.	R/W SC	0b
8	Duplex Mode 0 = half duplex 1 = full duplex Note: Ignored if the Auto-Negotiation Enable bit of this register is 1.	R/W	Note 4.1
7	Collision Test 0 = disable COL test 1 = enable COL test	R/W	0b
6	Speed Select[1] See description for Speed Select[0] for details.	RO	Note 4.1
5:0	RESERVED	RO	-

Note 4.1 The default is determined by the CONFIG[3:2] pins as described in [Section 3.8.1.2.3, "Configuration Bits Impacted by the Mode of Operation," on page 33](#)

Datasheet

4.2.2 Basic Status Register

Index (In Decimal): 1

Size: 16 bits

BITS	DESCRIPTION	TYPE	DEFAULT
15	100BASE-T4 0 = no T4 ability 1 = T4 able	RO	0b
14	100BASE-TX Full Duplex 0 = no TX full duplex ability 1 = TX with full duplex	RO	1b
13	100BASE-TX Half Duplex 0 = no TX half duplex ability 1 = TX with half duplex	RO	1b
12	10BASE-T Full Duplex 0 = no 10Mbps with full duplex ability 1 = 10Mbps with full duplex	RO	1b
11	10BASE-T Half Duplex 0 = no 10Mbps with half duplex ability 1 = 10Mbps with half duplex	RO	1b
10	100BASE-T2 Full Duplex 0 = PHY not able to perform full duplex 100BASE-T2 1 = PHY able to perform full duplex 100BASE-T2	RO	0b
9	100BASE-T2 Half Duplex 0 = PHY not able to perform half duplex 100BASE-T2 1 = PHY able to perform half duplex 100BASE-T2	RO	0b
8	Extended Status 0 = no extended status information in register 15 1 = extended status information in register 15	RO	1b
7:6	RESERVED	RO	-
5	Auto-Negotiate Complete 0 = auto-negotiate process not completed 1 = auto-negotiate process completed	RO	0b
4	Remote Fault 0 = no remote fault 1 = remote fault condition detected	RO/LH	0b
3	Auto-Negotiate Ability 0 = unable to perform auto-negotiation function 1 = able to perform auto-negotiation function	RO	1b
2	Link Status 0 = link is down 1 = link is up	RO/LL	0b
1	Jabber Detect 0 = no jabber condition detected 1 = jabber condition detected	RO/LH	0b
0	Extended Capabilities 0 = does not support extended capabilities registers 1 = supports extended capabilities registers	RO	1b

4.2.3 PHY Identifier 1 Register

Index (In Decimal): 2

Size: 16 bits

BITS	DESCRIPTION	TYPE	DEFAULT
15:0	PHY ID Number Assigned to the 3rd through 18th bits of the Organizationally Unique Identifier (OUI), respectively. OUI=00800Fh	R/W	0007h

Datasheet

4.2.4 PHY Identifier 2 Register

Index (In Decimal): 3

Size: 16 bits

BITS	DESCRIPTION	TYPE	DEFAULT
15:10	PHY ID Number Assigned to the 19th through 24th bits of the OUI.	R/W	C0h
9:4	Model Number Six-bit manufacturer's model number.	R/W	0Ch
3:0	Revision Number Four-bit manufacturer's revision number.	R/W	Note 4.2

Note 4.2 The default value of this field will vary dependant on the silicon revision number.

4.2.5 Auto Negotiation Advertisement Register

Index (In Decimal): 4

Size: 16 bits

BITS	DESCRIPTION	TYPE	DEFAULT
15	Next Page 0 = no next page ability 1 = next page capable Note: This device does not support next page ability.	R/W	0b
14	RESERVED	RO	-
13	Remote Fault 0 = no remote fault 1 = remote fault detected	R/W	0b
12	RESERVED	RO	-
11	Asymmetric Pause 0 = Asymmetrical pause direction is not supported by MAC 1 = Asymmetrical pause direction is supported by MAC	R/W	0b
10	Pause Operation (PAUSE) 0 = Pause operation is not supported by MAC 1 = Pause operation is supported by MAC	R/W	Note 4.3
9	RESERVED	RO	-
8	100BASE-TX Full Duplex 0 = no TX full duplex ability 1 = TX with full duplex	R/W	Note 4.4
7	100BASE-TX 0 = no TX ability 1 = TX able	R/W	Note 4.4
6	10BASE-T Full Duplex 0 = no 10Mbps with full duplex ability 1 = 10Mbps with full duplex	R/W	Note 4.4
5	10BASE-T 0 = no 10Mbps ability 1 = 10Mbps able	R/W	Note 4.4
4:0	Selector Field 00001 = IEEE 802.3	R/W	00001b

Note 4.3 The default is determined by the CONFIG1 pin as described in [Section 3.8.1.2.1, "Configuring the SMI Address \(CONFIG\[1:0\]\)"](#), on page 30

Note 4.4 The default is determined by the CONFIG[3:2] pins as described in [Section 3.8.1.2.3, "Configuration Bits Impacted by the Mode of Operation"](#), on page 33.

Datasheet

4.2.6 Auto Negotiation Link Partner Ability Register

Index (In Decimal): 5

Size: 16 bits

BITS	DESCRIPTION	TYPE	DEFAULT
15	Next Page 0 = no next page ability 1 = next page capable	RO	0b
14	Acknowledge 0 = link code word not yet received 1 = link code word received from partner	RO	0b
13	Remote Fault 0 = no remote fault 1 = remote fault detected	RO	0b
12:11	RESERVED	RO	-
10	Pause Operation (PAUSE) 0 = Pause Operation is not supported by remote MAC 1 = Pause Operation is supported by remote MAC	RO	0b
9	100BASE-T4 0 = no T4 ability 1 = T4 able Note: This PHY does not support T4 ability.	RO	0b
8	100BASE-TX Full Duplex 0 = no TX full duplex ability 1 = TX with full duplex	RO	0b
7	100BASE-TX 0 = no TX ability 1 = TX able	RO	0b
6	10BASE-T Full Duplex 0 = no 10Mbps with full duplex ability 1 = 10Mbps with full duplex	RO	0b
5	10BASE-T 0 = no 10Mbps ability 1 = 10Mbps able	RO	0b
4:0	Selector Field 00001 = IEEE 802.3	RO	00001b

4.2.7 Auto Negotiation Expansion Register

Index (In Decimal): 6

Size: 16 bits

BITS	DESCRIPTION	TYPE	DEFAULT
15:5	RESERVED	RO	-
4	Parallel Detection Fault 0 = no fault detected by parallel detection logic 1 = fault detected by parallel detection logic	RO/LH	0b
3	Link Partner Next Page Able 0 = link partner does not have next page ability 1 = link partner has next page ability	RO	0b
2	Next Page Able 0 = local device does not have next page ability 1 = local device has next page ability	RO	0b
1	Page Received 0 = new page not yet received 1 = new page received	RO/LH	0b
0	Link Partner Auto-Negotiation Able 0 = link partner does not have auto-negotiation ability 1 = link partner has auto-negotiation ability	RO	0b

Datasheet

4.2.8 Auto Negotiation Next Page TX Register

Index (In Decimal): 7

Size: 16 bits

BITS	DESCRIPTION	TYPE	DEFAULT
15	Next Page 0 = no next page ability 1 = next page capable	R/W	0b
14	RESERVED	RO	-
13	Message Page 0 = unformatted page 1 = message page	R/W	1b
12	Acknowledge 2 0 = device cannot comply with message 1 = device will comply with message	R/W	0b
11	Toggle 0 = previous value was HIGH 1 = previous value was LOW	RO	0b
10:0	Message Code Message/Unformatted Code Field	RW	00 0000 0001b

4.2.9 Auto Negotiation Next Page RX Register

Index (In Decimal): 8

Size: 16 bits

BITS	DESCRIPTION	TYPE	DEFAULT
15	Next Page 0 = no next page ability 1 = next page capable	RO	0b
14	Acknowledge 0 = Link code word not yet received from partner 1 = Link code word received from partner	RO	0b
13	Message Page 0 = unformatted page 1 = message page	RO	1b
12	Acknowledge 2 0 = device cannot comply with message 1 = device will comply with message	RO	0b
11	Toggle 0 = previous value was HIGH 1 = previous value was LOW	RO	0b
10:0	Message Code Message/Unformatted Code Field	RO	000 0000 0000b

Datasheet

4.2.10 Master/Slave Control Register

Index (In Decimal): 9

Size: 16 bits

BITS	DESCRIPTION	TYPE	DEFAULT
15:13	Test Mode 000 = Normal mode 001 = Test Mode 1 - Transmit waveform test 010 = Test Mode 2 - Transmit jitter test in Master mode 011 = Test Mode 3 - Transmit jitter test in Slave mode 100 = Test Mode 4 - Transmitter distortion test 101 = Reserved 110 = Reserved 111 = Reserved Note: Setting these bits may prevent correct link partner connection if both the device PHY and link partner PHY are set as masters.	R/W	000b
12	Master/Slave Manual Config Enable 0 = disable MASTER-SLAVE manual configuration value 1 = enable MASTER-SLAVE manual configuration value	R/W	Note 4.5
11	Master/Slave Manual Config Value Active only when the Master/Slave Manual Config Enable bit of this register is 0. 0 = Slave 1 = Master	R/W	Note 4.5
10	Port Type Active only when the Master/Slave Manual Config Enable bit of this register is 0. 0 = Single port device 1 = Multiport device	R/W	Note 4.5
9	1000BASE-T Full Duplex 0 = advertise PHY is not 1000BASE-T full duplex capable 1 = advertise PHY is 1000BASE-T full duplex capable	R/W	Note 4.5
8	1000BASE-T Half Duplex 0 = advertise PHY is not 1000BASE-T half duplex capable 1 = advertise PHY is 1000BASE-T half duplex capable	R/W	Note 4.5
7:0	RESERVED	RO	-

Note 4.5 The default is determined by the CONFIG[3:2] pins as described in [Section 3.8.1.2.3, "Configuration Bits Impacted by the Mode of Operation,"](#) on page 33.

4.2.11 Master/Slave Status Register

Index (In Decimal): 10

Size: 16 bits

BITS	DESCRIPTION	TYPE	DEFAULT
15	Master/Slave Configuration Fault 0 = No MASTER-SLAVE configuration fault detected 1 = MASTER-SLAVE configuration fault detected	RO/LH	0b
14	Master/Slave Configuration Resolution 0 = Local PHY configuration resolved to SLAVE 1 = Local PHY configuration resolved to MASTER	RO	0b
13	Local Receiver Status 0 = Local Receiver not OK 1 = Local Receiver OK	RO	0b
12	Remote Receiver Status 0 = Remote Receiver not OK 1 = Remote Receiver OK	RO	0b
11	LP 1000T FD This bit is valid only when the Page Received bit of the Auto Negotiation Expansion Register is 1. 0 = Link Partner is not capable of 1000BASE-T full duplex 1 = Link Partner is capable of 1000BASE-T full duplex	RO	0b
10	LP 1000T HD This bit is valid only when the Page Received bit of the Auto Negotiation Expansion Register is 1. 0 = Link Partner is not capable of 1000BASE-T half duplex 1 = Link Partner is capable of 1000BASE-T half duplex	RO	0b
9:8	RESERVED	RO	-
7:0	Idle Error Count Cumulative count of the errors detected when the receiver is receiving idles. These bits are reset to all zeroes when the error count is read by the management function or upon execution of a hardware reset, software reset, or logical reset. This field is held at all ones in case of over-flow. This field can be used to trigger an interrupt upon overflow. Refer to Section 3.5, "Interrupt Management," on page 26 for additional information.	RO	00h

Datasheet

4.2.12 Extended Status Register

Index (In Decimal): 15

Size: 16 bits

BITS	DESCRIPTION	TYPE	DEFAULT
15	1000BASE-X Full Duplex 0 = PHY not able to perform full duplex 1000BASE-X 1 = PHY able to perform full duplex 1000BASE-X	RO	0b
14	1000BASE-X Half Duplex 0 = PHY not able to perform half duplex 1000BASE-X 1 = PHY able to perform half duplex 1000BASE-X	RO	0b
13	1000BASE-T Full Duplex 0 = PHY not able to perform full duplex 1000BASE-T 1 = PHY able to perform full duplex 1000BASE-T	RO	1b
12	1000BASE-T Half Duplex 0 = PHY not able to perform half duplex 1000BASE-T 1 = PHY able to perform half duplex 1000BASE-T	RO	1b
11:0	RESERVED	RO	-

4.2.13 Link Control Register

Index (In Decimal): 16

Size: 16 bits

BITS	DESCRIPTION	TYPE	DEFAULT
15:10	RESERVED	RO	-
9:8	<p>Speed Optimize Control This register sets the number of Auto Negotiation attempts before the Speed Optimize mechanism reduces the advertised speed. 00 = 7 attempts 01 = 5 attempts 10 = 4 attempts 11 = 3 attempts</p> <p>Note: Refer to Section 3.9.7, "Speed Optimizer," on page 38 for additional information.</p>	R/W	00b
7:6	RESERVED	RO	-
5:4	<p>Link Break Threshold Idle error threshold for failing the link, if Link break in enabled. 00 = link break threshold is 10E-8. 01 = link break threshold is 10E-9. 10 = link break threshold is 10E-10. 11 = link break threshold is 10E-11</p>	R/W	10b
3	<p>Link Break Enable 0 = link break is disabled 1 = link break is enabled</p>	R/W	0b
2	<p>Power Optimization Disable 0 = Automatic power optimization is enabled 1 = Automatic power optimization is disabled (power consumption is maximum)</p>	R/W	0b
1	RESERVED	RO	-
0	<p>LRST Logic reset. This bit generates a reset that put all the logic into a known state, but DOES NOT affect the register sets and 10/100 circuits. This bit is NOT a self-clearing bit. Writing "1" to this bit generates synchronous reset.</p>	RO	-

Datasheet

4.2.14 10/100 Mode Control/Status Register

Index (In Decimal): 17

Size: 16 bits

BITS	DESCRIPTION	TYPE	DEFAULT
15	EDSHORT Energy Detect Short detection mode 0 = Normal detect mode 1 = Short detect mode	R/W	0b
14	FASTRIP 10BASE-T fast mode 0 = normal operation 1 = activates PHYT_10 test mode	R/W	0b
13	EDPWRDOWN Enable the Energy Detect Power-Down mode 0 = Energy Detect Power-Down is disabled 1 = Energy Detect Power-Down is enabled	R/W	0b
12	ED Power Down Mode Select energy detect power down mode 0 = ED power down mode without NLP transmission 1 = ED power down mode with NLP transmission	R/W	0b
11:8	RESERVED	RO	-
7	Speed Optimize Enable 0 = Disable Speed Optimize 1 = Enable Speed Optimize Note: Refer to Section 3.9.7, "Speed Optimizer," on page 38 for additional information.	R/W	0b
6	AutoNeg NP Enable 0 = Next page is disabled in the auto-negotiation process 1 = Next page is enabled in the auto-negotiation process	R/W	1b
5	Auto MDIX Disable 0 = Auto Xover is enabled 1 = Auto Xover is disabled selection is done manually	R/W	0b
4	Auto Next Page Disable Setting this bit disables automatic next page exchange in 1000BASE-T. Advertising of next pages then depends on the value of the Next Page bit of the Auto Negotiation Advertisement Register . In this case, if Next Page is cleared, only the base page is sent. 0 = Normal operation 1 = Automatic next page is disabled	R/W	0b
3:2	RESERVED	RO	-
1	ENERGYON This bit indicates whether energy is detected on the line. It is reset to "1" by a hardware reset. When a software reset is asserted, this bit is cleared. If this bit was set prior to a software reset, it will cause the INT7 bit of the Interrupt Source Flags Register to be set. Therefore, after a software or hardware reset, the INT7 bit should be cleared by writing a "1" to it. Refer to Section 3.5, "Interrupt Management," on page 26 for additional ENERGYON information.	RO	1b

BITS	DESCRIPTION	TYPE	DEFAULT
0	Semi Crossover Enable Setting this register enables semi cross over. 0 = Disable Semi cross over 1 = Enable Semi cross over Note: Refer to Section 3.2, "HP Auto-MDIX," on page 22 for additional information.	R/W	0b

Datasheet

4.2.15 10/100 Special Modes Register

Index (In Decimal): 18

Size: 16 bits

BITS	DESCRIPTION	TYPE	DEFAULT
15	Enable RXDV Early Assertion Setting this bit enables early assertion of RXDV in 10BASE-T. RXDV is asserted before the SFD. 0 = Disable 1 = Enable	R/W	0b
14	10BT HD Loopback Disable Setting this bit disables MII loopback in 10BASE-T half duplex mode. 0 = normal operation 1 = activates PHYT_10 test mode	R/W NASR	000000b
13:8	RESERVED	RO	-
7	CRC Error Counter Data Source Setting this bit changes the data source of the 1000BASE-T CRC error counter. 0 = Data source in 1000BASE-T received data 1 = Data source in 1000BASE-T transmitted data	R/W	0b
6	MCLK25EN Enable an 25Mhz MAC clock output. 0 = 125MHz 1 = 25MHz	RO	0b
5	RESERVED	RO	-
4:0	PHYADD[4:0] The PHY Address is used for the SMI address and for the initialization of the Cipher (Scrambler) key.	R/W NASR	Note 4.6

Note 4.6 The default is determined by the CONFIG[1:0] pins as described in [Section 3.8.1.2.1, "Configuring the SMI Address \(CONFIG\[1:0\]\),"](#) on page 30.

4.2.16 Extended Mode Control/Status Register

Index (In Decimal): 19

Size: 16 bits

BITS	DESCRIPTION	TYPE	DEFAULT
15:11	MOD Configures mode of operation. Refer to Section 3.8.1.2.2, "Configuring the Mode of Operation (CONFIG[3:2])" , on page 31 for details.	R/W NASR	Note 4.7
10:9	Transmitter FIFO Depth 00 = 4 bytes 01 = 5 bytes 10 = 6 bytes 11 = 7 bytes	R/W	00b
8:6	RESERVED	RO	-
5:4	LED_MODE[1:0] 00 = Reserved 01 = LED mode 1 10 = LED mode 2 11 = LED mode 3 Refer to Section 3.9.1, "LEDs," on page 34 for additional information.	R/W	11b
3	MACCLKDIS 0 = Normal mode, MACCLK pin is toggling at 125MHz or 25MHz 1 = Disable MACCLK pin from toggling, (driving it low)	R/W NASR	Note 4.8
2	MDI/MDI-X 0:1 Selects between MDI and MDI-X for channel 0 and channel 1 only if the Auto MDIX Disable bit of the 10/100 Mode Control/Status Register is 1. 0 = MDI 1 = MDI-X	RW	0b
1	MDI/MDI-X 2:3 Selects between MDI and MDI-X for channel 2 and channel 3 only if the Auto MDIX Disable bit of the 10/100 Mode Control/Status Register is 1. 0 = MDI 1 = MDI-X	RW	0b
0	CONDITIONAL PARALLEL DETECT 0 = Parallel detect. (Auto Negotiation Advertisement Register is ignored.) 1 = Conditional Parallel Detect only at the speed advertised in the Auto Negotiation Advertisement Register . 10BASE-T half duplex (10BASE-T bit =1) 100BASE-TX half duplex (100BASE-TX bit =1)	RW	0b

Note 4.7 The default mode is determined by the CONFIG[3:2] pins as described in [Section 3.8.1.2.2, "Configuring the Mode of Operation \(CONFIG\[3:2\]\)"](#), on page 31

Note 4.8 .The default is determined by the CONFIG3 pin as described in [Section 3.8.1.2.2, "Configuring the Mode of Operation \(CONFIG\[3:2\]\)"](#), on page 31.

Datasheet

4.2.17 Advanced Register Address Port

Index (In Decimal): 20

Size: 16 bits

BITS	DESCRIPTION	TYPE	DEFAULT
15	Read When this bit is set to 1, the contents of the advanced register selected by the Register Address field are latched to the Advanced Register Read Data Port . This bit is self-cleared.	SC	0b
14:7	RESERVED Must be written with 00000011b for proper operation. The values of RESERVED bits are not guaranteed on a read.	R/W	-
6:0	Register Address The address of the Advanced Register being accessed (0-12).	RO	0000000b

Note: Refer to [Section 4.3, "Advanced PHY Registers,"](#) on [page 68](#) for additional information on the advanced register set.

4.2.18 Advanced Register Read Data Port

Index (In Decimal): 21

Size: 16 bits

BITS	DESCRIPTION	TYPE	DEFAULT
15:0	Read Data read from the Advanced Register selected via the Advanced Register Address Port .	RO	0000h

Note: Refer to [Section 4.3, "Advanced PHY Registers,"](#) on page 68 for additional information on the advanced register set.

Datasheet

4.2.19 Control / Status Indications Register

Index (In Decimal): 27

Size: 16 bits

BITS	DESCRIPTION	TYPE	DEFAULT
15:5	RESERVED	RO	-
4	XPOL Polarity state of the 10BASE-T: 0 = Normal polarity 1 = Reversed polarity	RO	0b
3:0	RESERVED	RO	-

4.2.20 Interrupt Source Flags Register

Index (In Decimal): 29

Size: 16 bits

BITS	DESCRIPTION	TYPE	DEFAULT
15:11	RESERVED	RO	-
10	INT10 0 = Not source of interrupt 1 = Transmitter Elastic Buffer Overflow	LH/WC	0b
9	INT9 0 = Not source of interrupt 1 = Transmitter Elastic Buffer Underflow	LH/WC	0b
8	INT8 0 = Not source of interrupt 1 = Idle Error Count Overflow	LH/WC	0b
7	INT7 0 = Not source of interrupt 1 = ENERGYON generated This bit is set when there is a "0" to "1" transition of the ENERGYON bit in the 10/100 Mode Control/Status Register . This occurs when transitioning from no energy detected to energy detected, or vice versa.	LH/WC	0b
6	INT6 0 = Not source of interrupt 1 = Auto-Negotiation complete	LH/WC	0b
5	INT5 0 = Not source of interrupt 1 = Remote Fault Detected	LH/WC	0b
4	INT4 0 = Not source of interrupt 1 = Link Down (link status negated)	LH/WC	0b
3	INT3 0 = Not source of interrupt 1 = Auto-Negotiation LP Acknowledged	LH/WC	0b
2	INT2 0 = Not source of interrupt 1 = Parallel Detection Fault or Master/Slave Configuration Fault	LH/WC	0b
1	INT1 0 = Not source of interrupt 1 = Auto-Negotiation Page Received	LH/WC	0b
0	RESERVED	RO	-

Note: Refer to [Section 3.5, "Interrupt Management,"](#) on page 26 for additional information.

Datasheet

4.2.21 Interrupt Mask Register

Index (In Decimal): 30

Size: 16 bits

BITS	DESCRIPTION	TYPE	DEFAULT
15:11	RESERVED	RO	-
10	INT10_EN Transmitter Elastic Buffer Overflow interrupt enable. 0 = interrupt source is masked 1 = interrupt source is enabled	R/W	0b
9	INT9_EN Transmitter Elastic Buffer Underflow interrupt enable. 0 = interrupt source is masked 1 = interrupt source is enabled	R/W	0b
8	INT8_EN Idle Error Count Overflow interrupt enable. 0 = interrupt source is masked 1 = interrupt source is enabled	R/W	0b
7	INT7_EN ENERGYON interrupt enable 0 = interrupt source is masked 1 = interrupt source is enabled	R/W	0b
6	INT6_EN Auto-Negotiation interrupt enable 0 = interrupt source is masked. 1 = interrupt source is enabled.	R/W	0b
5	INT5_EN Remote Fault Detected interrupt enable. 0 = interrupt source is masked. 1 = interrupt source is enabled.	R/W	0b
4	INT4_EN Link Down (Link status negated) interrupt enable. 0 = interrupt source is masked. 1 = interrupt source is enabled.	R/W	0b
3	INT3_EN Auto-Negotiation LP Acknowledge interrupt enable. 0 = interrupt source is masked. 1 = interrupt source is enabled.	R/W	0b
2	INT2_EN Parallel Detection Fault or Master/Slave Configuration Fault interrupt enable. 0 = interrupt source is masked. 1 = interrupt source is enabled.	R/W	0b
1	INT1_EN Auto-Negotiation Page Received interrupt enable. 0 = interrupt source is masked. 1 = interrupt source is enabled.	R/W	0b
0	RESERVED	RO	-

Note: Refer to [Section 3.5, "Interrupt Management,"](#) on [page 26](#) for additional information.

4.2.22 PHY Special Control / Status Register

Index (In Decimal): 31

Size: 16 bits

BITS	DESCRIPTION	TYPE	DEFAULT
15:13	RESERVED	RO	-
12	Auto-negotiation done indication 0 = Auto-negotiation is not done or disabled (or not active) 1 = Auto-negotiation is done Note: This is a duplicate of register 1.5, however reads to register 31 do not clear status bits.	RO	0b
11:5	RESERVED	RO	-
4:2	Speed Indication HCDSPEED value: [001]=10Mbps Half-duplex [101]=10Mbps Full-duplex [010]=100BASE-TX Half-duplex [110]=100BASE-TX Full-duplex	RO	Note 4.9
1:0	RESERVED	RO	-

Note 4.9 Set according to the results of Auto-Negotiation.

4.3 Advanced PHY Registers

The advanced PHY registers are accessed using the following procedure:

1. Write to the [Advanced Register Address Port](#) with the [Read](#) bit set high, and the address of the desired advanced register in the [Register Address](#) field.
2. Read the contents of the selected register from [Advanced Register Read Data Port](#).

Note: The advanced registers cannot be written. All advanced registers are comprised of read-only (RO), or read-to-clear (RC) bits.

4.3.1 Advanced Register Mapping

Table 4.3 Advanced Register Mapping

REGISTER NUMBER	REGISTER NAME
U0	User Status 1 Register
U1	User Status 2 Register
U2	Receive Error-Free Packets Counter High Register
U3	Receive Error-Free Packets Counter Mid Register
U4	Receive Error-Free Packets Counter Low Register
U5	CRC Error Counter High Register
U6	CRC Error Counter Mid Register
U7	CRC Error Counter Low Register
U8	Receive Error During Data Counter Register
U9	Receive Error During Idle Counter Register
U10	Transmit Packet Counter High Register
U11	Transmit Packet Counter Mid Register
U12	Transmit Packet Counter Low Register

4.3.2 User Status 1 Register

Index: U0 Size: 16 bits

BITS	DESCRIPTION	TYPE	DEFAULT
15	PLLREADY 0 = PLL is not locked 1 = PLL is locked	RO	0b
14	POLARITY_INV_3 This bit indicates reverse polarity on channel 3 when operating in 1000BASE-T mode. 0 = Channel 3 polarity is correct 1 = Channel 3 polarity is reversed	RO	0b
13	POLARITY_INV_2 This bit indicates reverse polarity on channel 2 when operating in 1000BASE-T mode. 0 = Channel 2 polarity is correct 1 = Channel 2 polarity is reversed	RO	0b
12	POLARITY_INV_1 This bit indicates reverse polarity on channel 1 when operating in 1000BASE-T mode. 0 = Channel 1 polarity is correct 1 = Channel 1 polarity is reversed	RO	0b
11	POLARITY_INV_0 This bit indicates reverse polarity on channel 0 when operating in 1000BASE-T mode. 0 = Channel 0 polarity is correct 1 = Channel 0 polarity is reversed	RO	0b
10:9	RESERVED	RO	-
8	CLKREF_SEL 0 = Reference clock frequency = 125MHz 1 = Reference clock frequency = 25MHz The value of this bit is based upon the configuration strap settings, as detailed in Section 3.8.1.1, "Configuration Straps," on page 29.	RO	0b
7:0	RESERVED	RO	-

Datasheet

4.3.3 User Status 2 Register

Index: U1 Size: 16 bits

BITS	DESCRIPTION	TYPE	DEFAULT
15	XOVER Resolution 0:1 0 = Channel 0 and Channel 1 resolved as MDI. 1 = Channel 0 and Channel 1 resolved as MDI-X.	RO	0b
14	XOVER Resolution 2:3 0 = Channel 2 and Channel 3 resolved as MDI. 1 = Channel 2 and Channel 3 resolved as MDI-X.	RO	0b
13	Speed Optimize Status When set, indicates the link was established using the Speed Optimize mechanism. Note: Refer to Section 3.9.7, "Speed Optimizer," on page 38 for additional information.	RO	0b
12:0	RESERVED	RO	-

4.3.4 Receive Error-Free Packets Counter High Register

Index: U2 Size: 16 bits

BITS	DESCRIPTION	TYPE	DEFAULT
15:0	RCVGPKT[47:32] Counts the received error-free packets. Contains the 16 upper bits of the 48-bit counter. Reading this register resets all bits in the Receive Error-Free Packets Counter.	RO/ RC	0000h

Note: The 48-bit receive error-free packets counter is split across 3 registers. In order to read the counter correctly, the registers must be read in the following order: [Receive Error-Free Packets Counter Low Register](#), [Receive Error-Free Packets Counter Mid Register](#), [Receive Error-Free Packets Counter High Register](#). After reading the high register, the counter will be automatically cleared.

Datasheet

4.3.5 Receive Error-Free Packets Counter Mid Register

Index: U3 Size: 16 bits

BITS	DESCRIPTION	TYPE	DEFAULT
15:0	RCVGPKT[31:16] Counts the received error-free packets. Contains the 16 middle bits of the 48-bit counter.	RO	0000h

Note: The 48-bit receive error-free packets counter is split across 3 registers. In order to read the counter correctly, the registers must be read in the following order: [Receive Error-Free Packets Counter Low Register](#), [Receive Error-Free Packets Counter Mid Register](#), [Receive Error-Free Packets Counter High Register](#). After reading the high register, the counter will be automatically cleared.

4.3.6 Receive Error-Free Packets Counter Low Register

Index: U4 Size: 16 bits

BITS	DESCRIPTION	TYPE	DEFAULT
15:0	RCVGPKT[15:0] Counts the received error-free packets. Contains the 16 low-order bits of the 48-bit counter.	RO	0000h

Note: The 48-bit receive error-free packets counter is split across 3 registers. In order to read the counter correctly, the registers must be read in the following order: [Receive Error-Free Packets Counter Low Register](#), [Receive Error-Free Packets Counter Mid Register](#), [Receive Error-Free Packets Counter High Register](#). After reading the high register, the counter will be automatically cleared.

Datasheet

4.3.7 CRC Error Counter High Register

Index: U5 Size: 16 bits

BITS	DESCRIPTION	TYPE	DEFAULT
15:0	CRCERR[47:32] Counts the CRC errors, which are generated by the CRC checker circuit. Contains the 16 upper bits of the 48-bit counter. Reading this register resets all bits in the CRC Error Counter.	RO/ RC	0000h

Note: The 48-bit CRC error counter is split across 3 registers. In order to read the counter correctly, the registers must be read in the following order: [CRC Error Counter Low Register](#), [CRC Error Counter Mid Register](#), [CRC Error Counter High Register](#). After reading the high register, the counter will be automatically cleared.

4.3.8 CRC Error Counter Mid Register

Index: U6 Size: 16 bits

BITS	DESCRIPTION	TYPE	DEFAULT
15:0	CRCERR[31:16] Counts the CRC errors, which are generated by the CRC checker circuit. Contains the 16 middle bits of the 48-bit counter.	RO	0000h

Note: The 48-bit CRC error counter is split across 3 registers. In order to read the counter correctly, the registers must be read in the following order: [CRC Error Counter Low Register](#), [CRC Error Counter Mid Register](#), [CRC Error Counter High Register](#). After reading the high register, the counter will be automatically cleared.

Datasheet

4.3.9 CRC Error Counter Low Register

Index: U7 Size: 16 bits

BITS	DESCRIPTION	TYPE	DEFAULT
15:0	CRCERR[15:0] Counts the CRC errors, which are generated by the CRC checker circuit. Contains the 16 low-order bits of the 48-bit counter.	RO	0000h

Note: The 48-bit CRC error counter is split across 3 registers. In order to read the counter correctly, the registers must be read in the following order: [CRC Error Counter Low Register](#), [CRC Error Counter Mid Register](#), [CRC Error Counter High Register](#). After reading the high register, the counter will be automatically cleared.

4.3.10 Receive Error During Data Counter Register

Index: U8 Size: 16 bits

BITS	DESCRIPTION	TYPE	DEFAULT
15:0	RXERIND_DATA[15:0] Counts the assertions of RXER (going from low to high) when RXDV is <u>high</u> .	RO/ RC	0000h

Datasheet

4.3.11 Receive Error During Idle Counter Register

Index: U9 Size: 16 bits

BITS	DESCRIPTION	TYPE	DEFAULT
15:0	RXERIND_IDLE[15:0] Counts the assertions of RXER (going from low to high) when RXDV is <u>low</u> .	RO/ RC	0000h

4.3.12 Transmit Packet Counter High Register

Index: U10 Size: 16 bits

BITS	DESCRIPTION	TYPE	DEFAULT
15:0	TXPKT[47:32] Counts the number of transmitted packets. Contains the 16 upper bits of the 48-bit counter. Reading this register resets all bits in the Transmit Packet Counter.	RO/ RC	0000h

Note: The 48-bit transmit packet counter is split across 3 registers. In order to read the counter correctly, the registers must be read in the following order: [Transmit Packet Counter Low Register](#), [Transmit Packet Counter Mid Register](#), [Transmit Packet Counter High Register](#). After reading the high register, the counter will be automatically cleared.

Datasheet

4.3.13 Transmit Packet Counter Mid Register

Index: U11 Size: 16 bits

BITS	DESCRIPTION	TYPE	DEFAULT
15:0	TXPKT[31:16] Counts the number of transmitted packets. Contains the 16 middle bits of the 48-bit counter.	RO	0000h

Note: The 48-bit transmit packet counter is split across 3 registers. In order to read the counter correctly, the registers must be read in the following order: [Transmit Packet Counter Low Register](#), [Transmit Packet Counter Mid Register](#), [Transmit Packet Counter High Register](#). After reading the high register, the counter will be automatically cleared.

4.3.14 Transmit Packet Counter Low Register

Index: U12 Size: 16 bits

BITS	DESCRIPTION	TYPE	DEFAULT
15:0	TXPKT[15:0] Counts the number of transmitted packets. Contains the 16 low-order bits of the 48-bit counter.	RO	0000h

Note: The 48-bit transmit packet counter is split across 3 registers. In order to read the counter correctly, the registers must be read in the following order: [Transmit Packet Counter Low Register](#), [Transmit Packet Counter Mid Register](#), [Transmit Packet Counter High Register](#). After reading the high register, the counter will be automatically cleared.

Chapter 5 Operational Characteristics

5.1 Absolute Maximum Ratings*

Supply Voltage (VDDVARIO) (Note 5.1)-0.5V to +3.6V
Analog Supply Voltage (VDD12A) (Note 5.1)-0.5V to +1.5V
Digital Core Supply Voltage (VDD12CORE) (Note 5.1)-0.5V to +1.5V
Ethernet Magnetics Supply Voltage-0.5V to +3.6V
Positive voltage on signal pins, with respect to ground (Note 5.2)+6.0V
Negative voltage on signal pins, with respect to ground (Note 5.3)-0.5V
Positive voltage on XI, with respect to ground+4.6V
Positive voltage on XO, with respect to ground+2.5V
Ambient Operating Temperature in Still Air (T_A) Note 5.4
Junction to Ambient (θ_{JA})22.5°C/W
Junction to Top of Package (Ψ_{JT})0.1°C/W
Storage Temperature-55°C to +150°C
Lead Temperature Range Refer to JEDEC Spec. J-STD-020
Latch-up Performance per EIA/JESD 78 +/-150mA

Note 5.1 When powering this device from laboratory or system power supplies, it is important that the absolute maximum ratings not be exceeded or device failure can result. Some power supplies exhibit voltage spikes on their outputs when AC power is switched on or off. In addition, voltage transients on the AC power line may appear on the DC output. If this possibility exists, it is suggested that a clamp circuit be used.

Note 5.2 This rating does not apply to the following pins: XI, XO, ETHRBIAS.

Note 5.3 This rating does not apply to the following pins: ETHRBIAS.

Note 5.4 0°C to +70°C for commercial version, -40°C to +85°C for industrial version.

*Stresses exceeding those listed in this section could cause permanent damage to the device. This is a stress rating only. Exposure to absolute maximum rating conditions for extended periods may affect device reliability. Functional operation of the device at any condition exceeding those indicated in Section 5.2, "Operating Conditions***", Section 5.4, "DC Specifications", or any other applicable section of this specification is not implied. Note, device signals are *NOT* 5 volt tolerant unless specified otherwise.

5.2 Operating Conditions**

Supply Voltage (VDDVARIO)	+2.25V to +3.6V
Supply Voltage (VDD12A).....	+1.14V to +1.26V
Digital Core Supply Voltage (VDD12CORE)	+1.14V to +1.26V
Ethernet Magnetics Supply Voltage	+2.25V to +3.6V
Ambient Operating Temperature in Still Air (T _A).....	Note 5.4

**Proper operation of the device is guaranteed only within the ranges specified in this section. After the device has completed power-up, VDDVARIO and the magnetics power supply must maintain their voltage level within +/-10%. Varying the voltage greater than +/-10% after the device has completed power-up can cause errors in device operation.

5.3 Power Consumption

This section details the power consumption of the device as measured during various modes of operation. Power consumption values are provided for both the device-only, and for the device plus Ethernet components. Power dissipation is impacted by temperature, supply voltage, and external source/sink requirements. All measurements were taken at +25°C.

Note: All power consumption values are preliminary and subject to change.

Table 5.1 Power Consumption - 1000BASE-T Linked

PARAMETER	TYPICAL	UNIT
Supply Current (VDDVARIO) (@ +3.3V)	36	mA
Supply Current (VDD12CORE, VDD12BIAS, VDD12PLL, VDD12A) (@ +1.2V)	454	mA
External Magnetics Current (@ +3.3V)	202	mA
Total Power Dissipation (Device Only) (Note 5.5)	665	mW
Total Power Dissipation (Device and Ethernet components) (Note 5.5)	1331	mW

Note 5.5 When the external magnetics operate at +2.5V, current consumption remains the same. However, Ethernet component power consumption will be reduced accordingly.

Table 5.2 Power Consumption - 100BASE-TX Linked

PARAMETER	TYPICAL	UNIT
Supply Current (VDDVARIO) (@ +3.3V)	24	mA
Supply Current (VDD12CORE, VDD12BIAS, VDD12PLL, VDD12A) (@ +1.2V)	82	mA
External Magnetics Current (@ +3.3V)	63	mA
Total Power Dissipation (Device Only) (Note 5.6)	177	mW
Total Power Dissipation (Device and Ethernet components) (Note 5.6)	385	mW

Note 5.6 When the external magnetics operate at +2.5V, current consumption remains the same. However, Ethernet component power consumption will be reduced accordingly.

Datasheet

Table 5.3 Power Consumption - 10BASE-T Linked

PARAMETER	TYPICAL	UNIT
Supply Current (VDDVARIO) (@ +3.3V)	21	mA
Supply Current (VDD12CORE, VDD12BIAS, VDD12PLL, VDD12A) (@ +1.2V)	32	mA
External Magnetics Current (@ +3.3V)	123	mA
Total Power Dissipation (Device Only) (Note 5.7)	107	mW
Total Power Dissipation (Device and Ethernet components) (Note 5.7)	513	mW

Note 5.7 When the external magnetics operate at +2.5V, current consumption remains the same. However, Ethernet component power consumption will be reduced accordingly.

Table 5.4 Power Consumption - Energy Detect

PARAMETER	TYPICAL	UNIT
Supply Current (VDDVARIO) (@ +3.3V)	30	mA
Supply Current (VDD12CORE, VDD12BIAS, VDD12PLL, VDD12A) (@ +1.2V)	28	mA
External Magnetics Current (@ +3.3V)	21	mA
Total Power Dissipation (Device Only) (Note 5.8)	133	mW
Total Power Dissipation (Device and Ethernet components) (Note 5.8)	203	mW

Note 5.8 When the external magnetics operate at +2.5V, current consumption remains the same. However, Ethernet component power consumption will be reduced accordingly.

Table 5.5 Power Consumption - Hardware Power Down (PLL Enabled)

PARAMETER	TYPICAL	UNIT
Supply Current (VDDVARIO) (@ +3.3V)	0.12	mA
Supply Current (VDD12CORE, VDD12BIAS, VDD12PLL, VDD12A) (@ +1.2V)	17.29	mA
External Magnetics Current (@ +3.3V)	7.00	mA
Total Power Dissipation (Device Only) (Note 5.9)	21.16	mW
Total Power Dissipation (Device and Ethernet components) (Note 5.9)	44.26	mW

Note 5.9 When the external magnetics operate at +2.5V, current consumption remains the same. However, Ethernet component power consumption will be reduced accordingly.

Table 5.6 Power Consumption - Hardware Power Down (PLL Disabled)

PARAMETER	TYPICAL	UNIT
Supply Current (VDDVARIO) (@ +3.3V)	0.12	mA
Supply Current (VDD12CORE, VDD12BIAS, VDD12PLL, VDD12A) (@ +1.2V)	4.39	mA
External Magnetics Current (@ +3.3V)	0.02	mA
Total Power Dissipation (Device Only) (Note 5.10)	5.68	mW
Total Power Dissipation (Device and Ethernet components) (Note 5.10)	5.73	mW

Note 5.10 When the external magnetics operate at +2.5V, current consumption remains the same. However, Ethernet component power consumption will be reduced accordingly.

5.4 DC Specifications

Table 5.7 I/O Buffer Characteristics

PARAMETER	SYMBOL	MIN	2.5V TYP	3.3V TYP	MAX	UNITS	NOTES
VIS Type Input Buffer							
Low Input Level	V_{ILI}	-0.3				V	
High Input Level	V_{IHI}				3.6	V	
Negative-Going Threshold	V_{ILT}	0.64	1.15	1.41	1.76	V	Schmitt trigger
Positive-Going Threshold	V_{IHT}	0.81	1.29	1.65	1.90	V	Schmitt trigger
SchmittTrigger Hysteresis ($V_{IHT} - V_{ILT}$)	V_{HYS}	102	136	138	288	mV	
Input Leakage ($V_{IN} = VSS$ or VDDVARIO)	I_{IH}	-10			10	uA	Note 5.11
Input Capacitance	C_{IN}				3	pF	
VO6 Type Buffers							
Low Output Level	V_{OL}				0.4	V	$I_{OL} = 6mA$
High Output Level	V_{OH}	VDDVARIO - 0.4				V	$I_{OH} = -6mA$
VO8 Type Buffers							
Low Output Level	V_{OL}				0.4	V	$I_{OL} = 8mA$
High Output Level	V_{OH}	VDDVARIO - 0.4				V	$I_{OH} = -8mA$
ICLK Type Buffer (XI Input)							
Low Input Level	V_{ILI}	-0.3			0.5	V	Note 5.12
High Input Level	V_{IHI}	1.4			3.6	V	

Note 5.11 This specification applies to all inputs and tri-stated bi-directional pins. Internal pull-down and pull-up resistors add +/- 50uA per-pin (typical).

Datasheet

Note 5.12 XI can optionally be driven from a 25MHz single-ended clock oscillator.

Table 5.8 1000BASE-T Transceiver Characteristics

PARAMETER	SYMBOL	MIN	TYP	MAX	UNITS	NOTES
Peak Differential Output Voltage	V_{OP}	670		820	mV	Note 5.13
Signal Amplitude Symmetry	V_{SS}			1	%	Note 5.13
Signal Scaling	V_{SC}			2	%	Note 5.14
Output Droop	V_{OD}	73.1			%	Note 5.13
Transmission Distortion				10	mV	Note 5.15

Note 5.13 IEEE 802.ab Test Mode 1

Note 5.14 From 1/2 of average V_{OP} Test Mode 1

Note 5.15 IEEE 802.ab distortion processing

Table 5.9 100BASE-TX Transceiver Characteristics

PARAMETER	SYMBOL	MIN	TYP	MAX	UNITS	NOTES
Peak Differential Output Voltage High	V_{PPH}	950	-	1050	mVpk	Note 5.16
Peak Differential Output Voltage Low	V_{PPL}	-950	-	-1050	mVpk	Note 5.16
Signal Amplitude Symmetry	V_{SS}	98	-	102	%	Note 5.16
Signal Rise and Fall Time	T_{RF}	3.0	-	5.0	nS	Note 5.16
Rise and Fall Symmetry	T_{RFS}	-	-	0.5	nS	Note 5.16
Duty Cycle Distortion	D_{CD}	35	50	65	%	Note 5.17
Overshoot and Undershoot	V_{OS}	-	-	5	%	
Jitter				1.4	nS	Note 5.18

Note 5.16 Measured at line side of transformer, line replaced by 100 Ω (+/- 1%) resistor.

Note 5.17 Offset from 16nS pulse width at 50% of pulse peak.

Note 5.18 Measured differentially.

Table 5.10 10BASE-T Transceiver Characteristics

PARAMETER	SYMBOL	MIN	TYP	MAX	UNITS	NOTES
Transmitter Peak Differential Output Voltage	V_{OUT}	2.2	2.5	2.8	V	Note 5.19
Receiver Differential Squelch Threshold	V_{DS}	300	420	585	mV	

Note 5.19 Min/max voltages guaranteed as measured with 100 Ω resistive load.

5.5 AC Specifications

This section details the various AC timing specifications of the device.

Note: The GMII/MII timing adheres to the IEEE 802.3 specification. Refer to the IEEE 802.3 specification for additional GMII/MII timing information.

Note: The Ethernet TX/RX pin timing adheres to the IEEE 802.3 specification. Refer to the IEEE 802.3 specification for detailed Ethernet timing information.

5.5.1 Equivalent Test Load

Output timing specifications assume a 25pF equivalent test load, unless otherwise noted, as illustrated in [Figure 5.1](#).

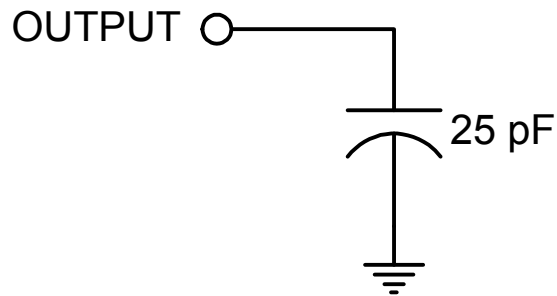

Figure 5.1 Output Equivalent Test Load

Datasheet

5.5.2 Power Sequence Timing

Power supplies must adhere to the following rules:

- All power supplies of the same voltage must be powered up/down together.
- There is no power-up sequencing requirement, however all power supplies must reach operational levels within the time periods specified in [Table 5.11](#).
- There is no power-down sequencing or timing requirement, however the device must not be powered for an extended period of time without all supplies at operational levels.
- Following initial power-on, or if a power supply brownout occurs (i.e., one or more supplies drops below operational limits), a power-on reset must be executed once all power supplies reach operational levels. Refer to [Section 5.5.3, "Power-On Reset Timing," on page 89](#) for power-on reset requirements.
- Do not drive input signals without power supplied to the device.

Note: Violation of these specifications may damage the device.

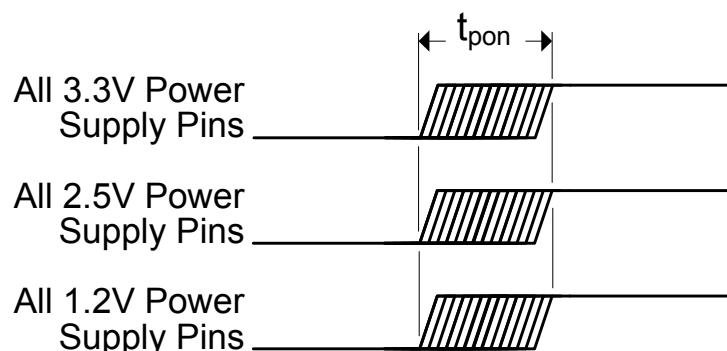

Figure 5.2 Power Sequence Timing

Table 5.11 Power Sequence Timing Values

SYMBOL	DESCRIPTION	MIN	TYP	MAX	UNITS
t_{pon}	Power supply turn on time	0		25	mS

Note: The VDDVARIO power supply can be run at 2.5V or 3.3V.

Note: The magnetics power supply can be run at 2.5V or 3.3V.

5.5.3 Power-On Reset Timing

Figure 5.3 illustrates the nRESET, configuration strap/pin, and CONFIG[3:0] timing requirements in relation to power-on. A hardware reset (nRESET assertion) is required following power-up. For proper operation, nRESET must be asserted for no less than t_{rstia} . The nRESET pin can be asserted at any time, but must not be deasserted before t_{purstd} after all external power supplies have reached operational levels. In order for valid configuration strap values to be read at power-up, the t_{css} and t_{csh} timing constraints must be followed. In order for CONFIG[3:0] values to be read at power-up, the t_{cs} and t_{ch} timing constraints must be followed. Refer to Section 3.6.1, "Hardware Reset (nRESET)," on page 27 for additional information.

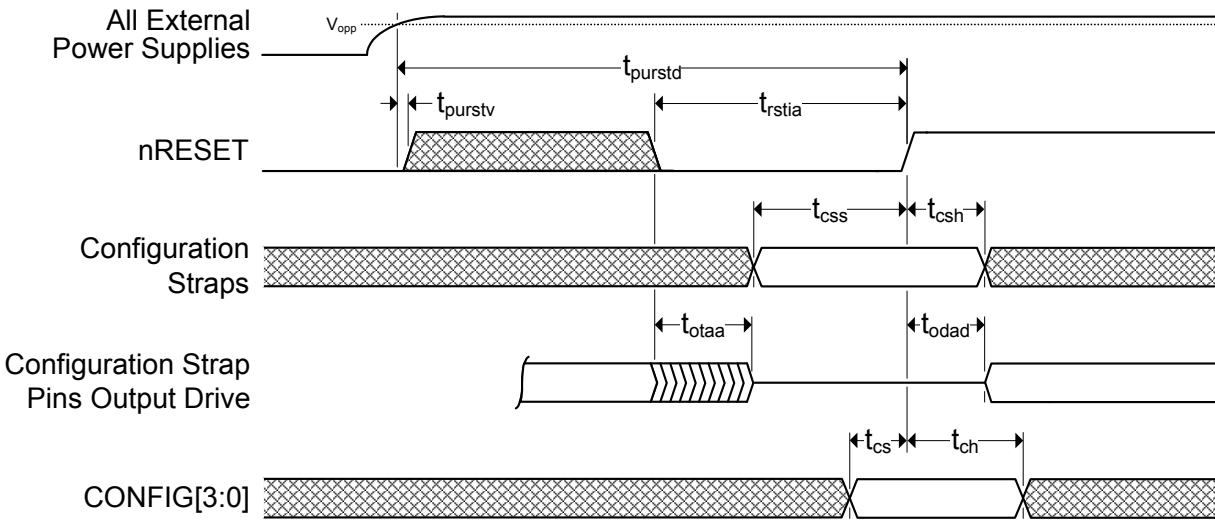

Figure 5.3 Power-On Reset Timing

Table 5.12 Power-On Reset Timing Values

SYMBOL	DESCRIPTION	MIN	TYP	MAX	UNITS
t_{purstd}	External power supplies at operational level to nRESET deassertion	25			mS
t_{purstv}	External power supplies at operational level to nRESET valid	0			nS
t_{rstia}	nRESET input assertion time	100			μ S
t_{css}	Configuration strap pins setup to nRESET deassertion	200			nS
t_{csh}	Configuration strap pins hold after nRESET deassertion	10			nS
t_{otaa}	Output tri-state after nRESET assertion			50	nS
t_{odad}	Output drive after deassertion	40		800	nS
t_{cs}	CONFIG[3:0] setup to nRESET deassertion	0			nS
t_{ch}	CONFIG[3:0] hold after nRESET deassertion	1			μ S

Note: Device configuration straps are latched as a result of nRESET assertion. Refer to Section 3.8.1.1, "Configuration Straps," on page 29 details. Configuration straps must only be pulled high or low and must not be driven as inputs.

Note: nRESET deassertion must be monotonic.

5.5.4 Reset Timing

Figure 5.4 illustrates the nRESET pin timing requirements. For proper operation, nRESET must be asserted for no less than t_{rstia} . In order for valid configuration strap values to be read upon a nRESET assertion, the t_{css} and t_{csh} timing constraints must be followed. In order for CONFIG[3:0] values to be read at power-up, the t_{cs} and t_{ch} timing constraints must be followed. Refer to Section 3.6.1, "Hardware Reset (nRESET)," on page 27 for additional information.

Note: A hardware reset (nRESET assertion) is required following power-up. Refer to Section 5.5.3, "Power-On Reset Timing," on page 89 for additional information.

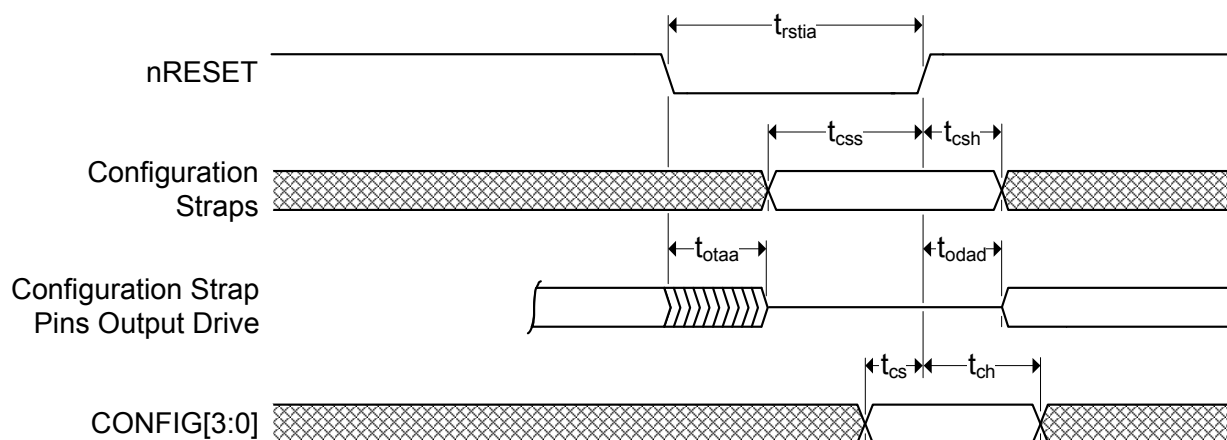

Figure 5.4 Reset Timing

Table 5.13 Reset Timing Values

SYMBOL	DESCRIPTION	MIN	TYP	MAX	UNITS
t_{rstia}	nRESET input assertion time	1			μ S
t_{css}	Configuration strap pins setup to nRESET deassertion	200			nS
t_{csh}	Configuration strap pins hold after nRESET deassertion	10			nS
t_{otaa}	Output tri-state after nRESET assertion			50	nS
t_{odad}	Output drive after deassertion	40		800	nS
t_{cs}	CONFIG[3:0] setup to nRESET deassertion	0			nS
t_{ch}	CONFIG[3:0] hold after nRESET deassertion	1			μ S

Note: Device configuration straps are latched as a result of nRESET assertion. Refer to Section 3.8.1.1, "Configuration Straps," on page 29 details. Configuration straps must only be pulled high or low and must not be driven as inputs.

5.5.5 GMI Timing (1000BASE-T)

This section specifies the GMI interface transmit and receive timing. Please refer to [Section 3.3, "GMI Interface,"](#) on page 24 for additional details.

Note: All GMI timing specifications assume a point-to-point test circuit as defined in Section 35.4.2.2 of the IEEE 802.3-2005 specification.

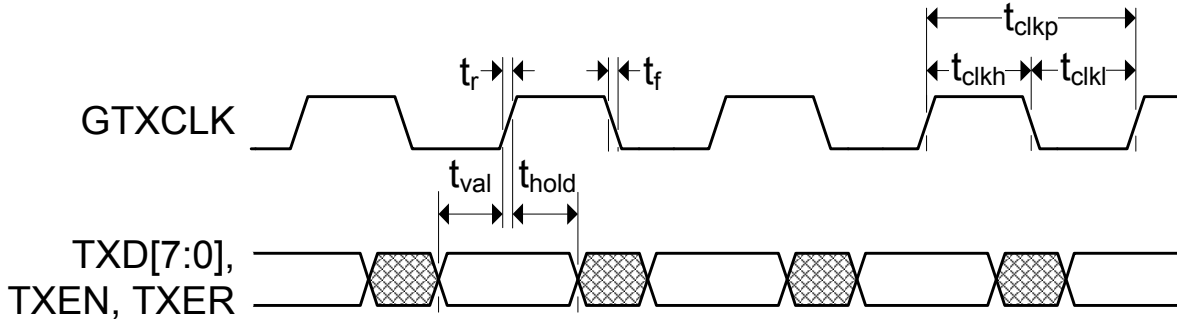

Figure 5.5 GMI Transmit Timing

Table 5.14 GMI Transmit Timing Values

SYMBOL	DESCRIPTION	MIN	MAX	UNITS	NOTES
f_{gtxclk}	GTXCLK Frequency	125 - 100ppm	125 + 100ppm	MHz	
t_{clkp}	GTXCLK period	7.5	8.5	ns	Note 5.20
t_{clkh}	GTXCLK high time	2.5		ns	
t_{clkl}	GTXCLK low time	2.5		ns	
t_{val}	TXD[7:0], TXEN, TXER setup time to rising edge of GTXCLK	2.0		ns	
t_{hold}	TXD[7:0], TXEN, TXER hold time after rising edge of GTXCLK	0.0		ns	
t_r	GTXCLK rise time		1	ns	Note 5.21
t_f	GTXCLK fall time		1	ns	Note 5.21

Note 5.20 Min/max limits are non-sustainable long term.

Note 5.21 t_r and t_f are measured from $V_{IL_AC(Max)}=0.7V$ to $V_{IH_AC(Min)}=1.9V$.

Datasheet

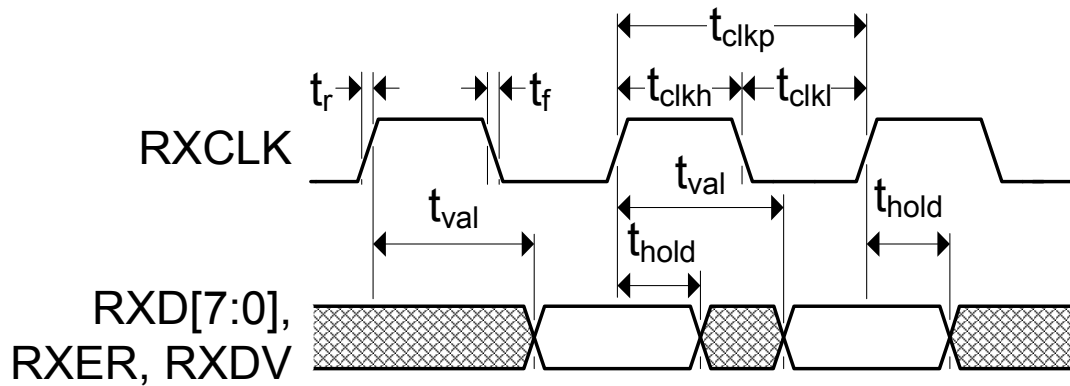

Figure 5.6 GMII Receive Timing

Table 5.15 GMII Receive Timing Values

SYMBOL	DESCRIPTION	MIN	MAX	UNITS	NOTES
t_{clkp}	RXCLK period	7.5		ns	
t_{clkh}	RXCLK high time	2.5		ns	
t_{clkl}	RXCLK low time	2.5		ns	
t_{val}	RXD[7:0], RXDV, RXER output valid from rising edge of RXCLK		5.0	ns	
t_{hold}	RXD[7:0], RXDV, RXER output hold from rising edge of RXCLK	0.5		ns	
t_r	RXCLK rise time		1	ns	Note 5.22
t_f	RXCLK fall time		1	ns	Note 5.22

Note 5.22 t_r and t_f are measured from $V_{IL_AC(Max)}=0.7V$ to $V_{IH_AC(Min)}=1.9V$.

5.5.6 MII Timing (100BASE-TX, 10BASE-T)

This section specifies the MII interface transmit and receive timing. Please refer to [Section 3.3, "GMII Interface,"](#) on page 24 for additional details.

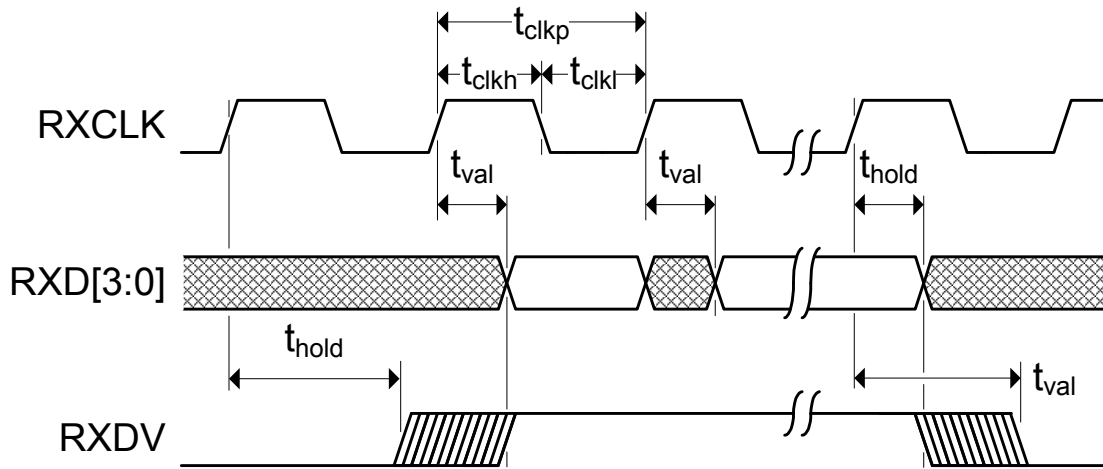

Figure 5.7 MII Receive Timing

Table 5.16 MII Receive Timing Values

SYMBOL	DESCRIPTION	MIN	MAX	UNITS	NOTES
t_{clkp}	RXCLK period	Note 5.23		ns	
t_{clkh}	RXCLK high time	$t_{clkp} * 0.4$	$t_{clkp} * 0.6$	ns	
t_{clkl}	RXCLK low time	$t_{clkp} * 0.4$	$t_{clkp} * 0.6$	ns	
t_{val}	RXD[3:0], RXDV output valid from rising edge of RXCLK		28.0	ns	Note 5.24
t_{hold}	RXD[3:0], RXDV output hold from rising edge of RXCLK	10.0		ns	Note 5.24

Note 5.23 40ns for 100BASE-TX operation, 400ns for 10BASE-T operation.

Note 5.24 Timing was designed for system load between 10 pf and 25 pf.

Datasheet

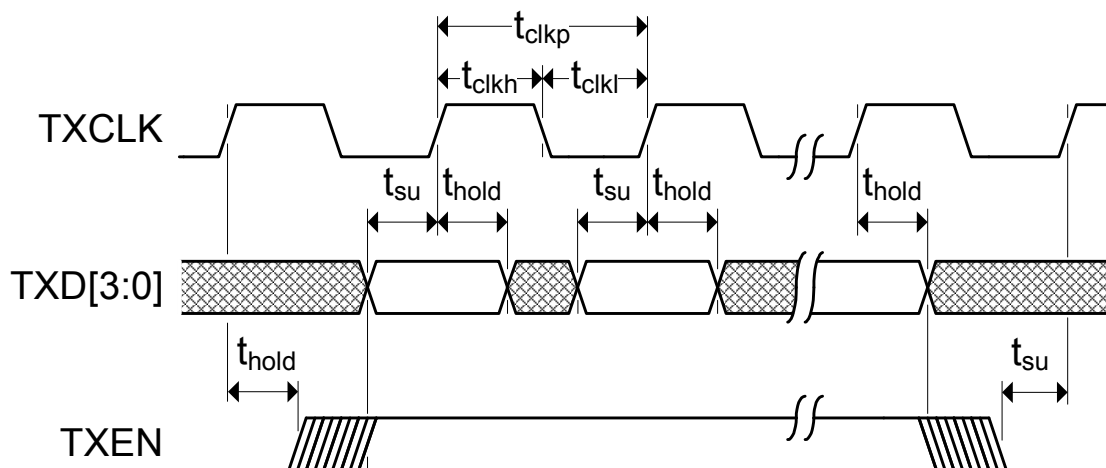

Figure 5.8 MII Transmit Timing

Table 5.17 MII Transmit Timing Values

SYMBOL	DESCRIPTION	MIN	MAX	UNITS	NOTES
t_{clkp}	TXCLK period	Note 5.25		ns	
t_{clkh}	TXCLK high time	$t_{clkp} * 0.4$	$t_{clkp} * 0.6$	ns	
t_{clkl}	TXCLK low time	$t_{clkp} * 0.4$	$t_{clkp} * 0.6$	ns	
t_{su}	TXD[3:0], TXEN setup time to rising edge of TXCLK	12.0		ns	Note 5.26
t_{hold}	TXD[3:0], TXEN hold time after rising edge of TXCLK	0		ns	Note 5.26

Note 5.25 40ns for 100BASE-TX operation, 400ns for 10BASE-T operation.

Note 5.26 Timing was designed for system load between 10 pf and 25 pf.

5.5.7 SMI Timing

This section specifies the SMI timing of the device. Please refer to [Section 3.4, "Serial Management Interface \(SMI\)," on page 25](#) for additional details.

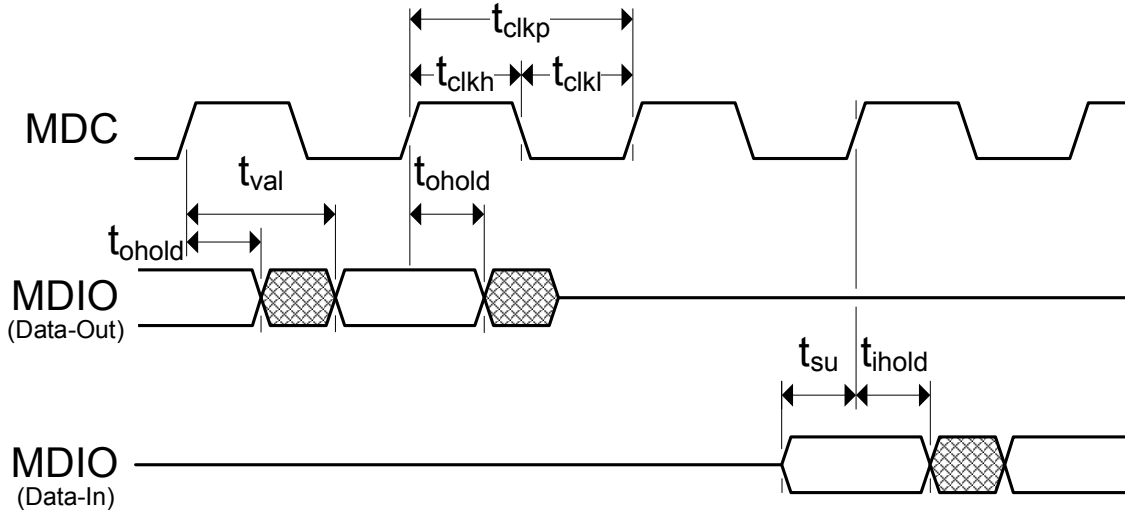

Figure 5.9 SMI Timing

Table 5.18 SMI Timing Values

SYMBOL	DESCRIPTION	MIN	MAX	UNITS	NOTES
t_{clkp}	MDC period	400		ns	
t_{clkh}	MDC high time	160 (80%)		ns	
t_{clkl}	MDC low time	160 (80%)		ns	
t_{val}	MDIO (read from PHY) output valid from rising edge of MDC		300	ns	
t_{hold}	MDIO (read from PHY) output hold from rising edge of MDC	0		ns	
t_{su}	MDIO (write to PHY) setup time to rising edge of MDC	10		ns	
t_{ihold}	MDIO (write to PHY) input hold time after rising edge of MDC	10		ns	

Datasheet

5.5.8 JTAG Timing

This section specifies the JTAG timing of the device. Please refer to [Section 3.9.9, "IEEE 1149.1 \(JTAG\) Boundary Scan,"](#) on page 39 for additional details.

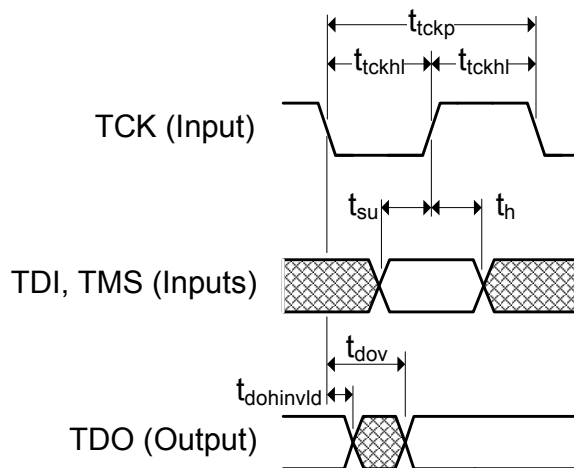

Figure 5.10 JTAG Timing

Table 5.19 JTAG Timing Values

SYMBOL	DESCRIPTION	MIN	MAX	UNITS	NOTES
t_{tckp}	TCK clock period	66.67		ns	
t_{tckhl}	TCK clock high/low time	$t_{tckp} * 0.4$	$t_{tckp} * 0.6$	ns	
t_{su}	TDI, TMS setup to TCK rising edge	10		ns	
t_h	TDI, TMS hold from TCK rising edge	10		ns	
t_{dov}	TDO output valid from TCK falling edge		16	ns	
$t_{dohinvld}$	TDO output invalid from TCK falling edge	0		ns	

5.6 Clock Circuit

The device can accept either a 25MHz crystal (preferred) or a 25MHz single-ended clock oscillator (+/- 50ppm) input. If the single-ended clock oscillator method is implemented, XO should be left unconnected and XI should be driven with a nominal 0-3.3V clock signal. The input clock duty cycle is 40% minimum, 50% typical and 60% maximum.

It is recommended that a crystal utilizing matching parallel load capacitors be used for the crystal input/output signals (XI/XO). See [Table 5.20](#) for the recommended crystal specifications.

Table 5.20 Crystal Specifications

PARAMETER	SYMBOL	MIN	NOM	MAX	UNITS	NOTES
Crystal Cut	AT, typ					
Crystal Oscillation Mode	Fundamental Mode					
Crystal Calibration Mode	Parallel Resonant Mode					
Frequency	F_{fund}	-	25.000	-	MHz	
Frequency Tolerance @ 25°C	F_{tol}	-	-	+/-50	PPM	Note 5.27
Frequency Stability Over Temp	F_{temp}	-	-	+/-50	PPM	Note 5.27
Frequency Deviation Over Time	F_{age}	-	+/-3 to 5	-	PPM	Note 5.28
Total Allowable PPM Budget		-	-	+/-50	PPM	Note 5.29
Shunt Capacitance	C_O	-		7	pF	
Load Capacitance	C_L	-		18	pF	
Drive Level	P_W	300	-	-	uW	
Equivalent Series Resistance	R_1	-	-	50	Ohm	
Operating Temperature Range		Note 5.30	-	Note 5.31	°C	
XI Pin Capacitance		-	3 typ	-	pF	Note 5.32
XO Pin Capacitance		-	3 typ	-	pF	Note 5.32

Note 5.27 The maximum allowable values for Frequency Tolerance and Frequency Stability are application dependant. Since any particular application must meet the IEEE +/-50 PPM Total PPM Budget, the combination of these two values must be approximately +/-45 PPM (allowing for aging).

Note 5.28 Frequency Deviation Over Time is also referred to as Aging.

Note 5.29 The total deviation for the Transmitter Clock Frequency is specified by IEEE 802.3u as +/- 50 PPM.

Note 5.30 0°C for commercial version, -40°C for industrial version.

Note 5.31 +70°C for commercial version, +85°C for industrial version.

Note 5.32 This number includes the pad, the bond wire and the lead frame. PCB capacitance is not included in this value. The XO/XI pin and PCB capacitance values are required to accurately calculate the value of the two external load capacitors. These two external load capacitors determine the accuracy of the 25.000 MHz frequency.

Chapter 6 Package Outline

6.1 72-QFN Package

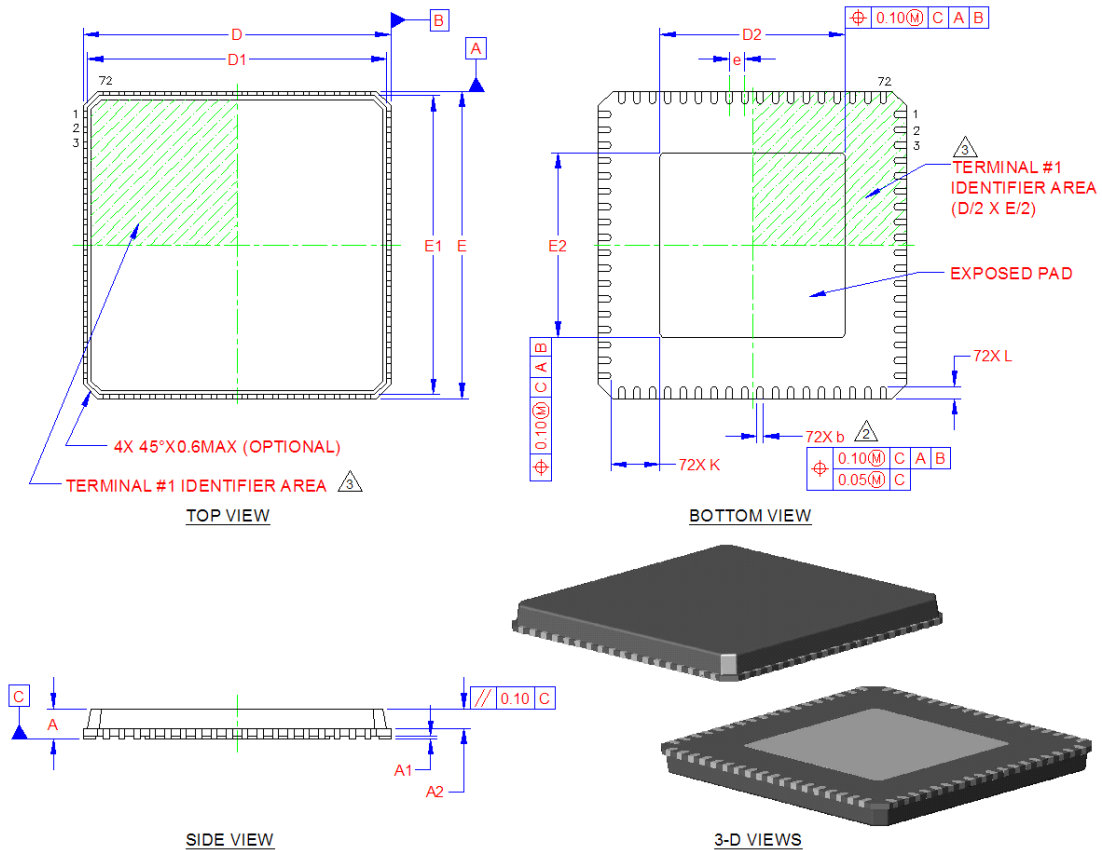

Figure 6.1 72-QFN Package

Table 6.1 72-QFN Dimensions

	MIN	NOMINAL	MAX	REMARKS
A	0.80	0.85	1.00	Overall Package Height
A1	0.00	0.02	0.05	Standoff
A2	-	0.65	0.80	Mold Cap Thickness
D/E	9.90	10.00	10.10	X/Y Body Size
D1/E1	9.65	9.75	9.85	X/Y Mold Cap Size
D2/E2	5.90	6.00	6.10	X/Y Exposed Pad Size
L	0.30	0.40	0.50	Terminal Length
b	0.18	0.25	0.30	Terminal Width
K	1.50	-	-	Center Pad to Pin Clearance
e	0.50 BSC			Terminal Pitch

Notes:

1. All dimensions are in millimeters unless otherwise noted.
2. Dimension "b" applies to plated terminals and is measured between 0.15 and 0.30 mm from the terminal tip.
3. The pin 1 identifier may vary, but is always located within the zone indicated.

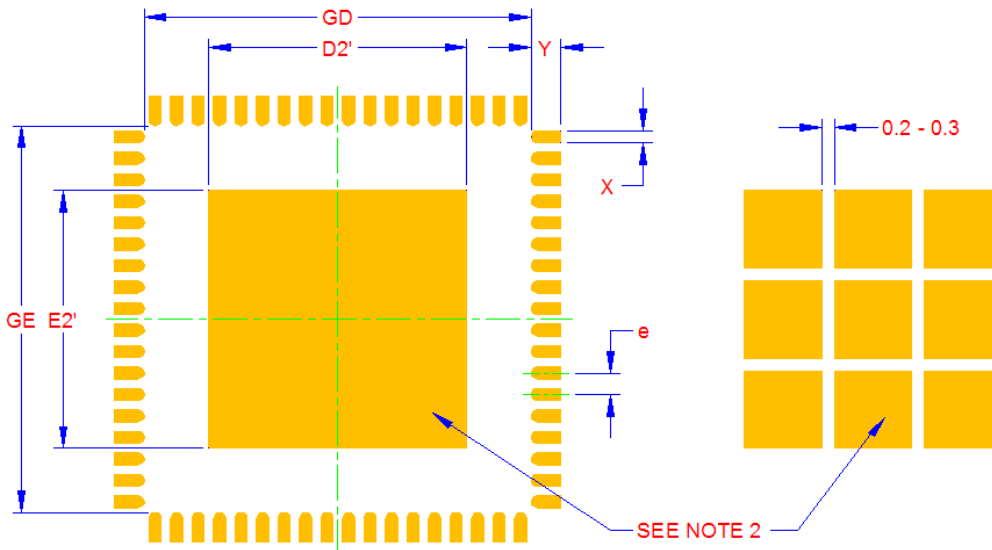

LAND PATTERN DIMENSIONS			
SYMBOL	MIN	NOM	MAX
GD/GE	9.00	-	9.10
D2'/E2'	-	6.00	-
X	-	0.28	0.28
Y	-	0.69	0.69
e		0.50	

NOTES:

1. THE USER MAY MODIFY THE PCB LAND PATTERN DESIGN AND DIMENSIONS BASED ON THEIR EXPERIENCE AND/OR PROCESS CAPABILITY
2. EXPOSED SOLDERABLE COPPER AREA OF THE CENTER PAD CAN BE EITHER SOLID OR SEGMENTED
3. MAXIMUM THERMAL AND ELECTRICAL PACKAGE PERFORMANCE IS ACHIEVED WHEN AN ARRAY OF SOLID VIAS IS INCORPORATED IN THE CENTER LAND PATTERN

PCB LAND PATTERN

Figure 6.2 72-QFN Recommended PCB Land Pattern

Chapter 7 Datasheet Revision History

Table 7.1 Customer Revision History

REVISION LEVEL & DATE	SECTION/FIGURE/ENTRY	CORRECTION
Rev. 1.0 (02-06-13)		Document co-branded: Microchip logo added, company disclaimer modified.
Rev. 1.0 (08-02-12)	Section 5.3, "Power Consumption"	Updated power numbers with latest lab measurements.
	All	Added commercial version.
	Table 5.15, "GMII Receive Timing Values," on page 92	Removed t_{val} min value and added t_{val} max value of 5.0ns.
Rev. 1.0 (06-29-11)	All	Initial release