

---

## Low Power PCIe to Gigabit Ethernet Controller with Integrated Ethernet MAC / PHY

---

### Highlights

- Single Chip PCIe to 10/100/1000 Ethernet Controller with integrated:
  - PCIe 3.1 PHY supporting 1 Lane at 2.5GT/s
  - PCIe 3.1 Endpoint Controller
  - Gigabit Ethernet PHY (LAN7430)
  - RGMII v1.3 and v2.0 / MII (LAN7431)
- IEEE Std 1588™-2008 PTP
  - Master and Slave Ordinary clock support
  - End-to-end or peer-to-peer support
  - PTP multicast and unicast message support
  - PTP message transport over IPv4/v6, IEEE 802.3
- Power Management
  - PCI-PM and ASPM L0s and L1
  - L1.1 and L1.2 PCIe sub-states support
  - D3 hot / cold with VAUX detection for PME wakeup
  - Wake on LAN support (WoL, AOAC)
  - IEEE 802.3az Energy Efficient Ethernet (EEE) with 100BASE-TX/1000BASE-T Low Power Idle and 10BASE-Tx TX Amplitude Reduction (LAN7430)

### Target Applications

- Automotive Infotainment / Telematics
- PCIe to Gigabit Ethernet Adapter / Bridge
- PCIe to Gigabit Ethernet on Embedded System
- Gigabit Backplane
- LTE Modem
- Networked Cameras
- Industrial PC (IPC)
- Test Instrumentation / Industrial

### System Considerations

- Power and I/Os
  - Single 3.3V supply operation with on-chip Switching and LDO Regulators for core and I/Os
  - GPIOs: 4 (LAN7430), 12 (LAN7431)
  - Variable voltage I/O supply (1.8V, 2.5V, or 3.3V)
- Software Support
  - Windows 7, 8, 8.1, 10, and OneCore drivers
  - Linux driver
  - Android driver
  - Windows command line OTP / EEPROM programming and testing utility
- Packaging
  - LAN7430: 48-pin SQFN (7 x 7 mm)
  - LAN7431: 72-pin SQFN (10 x 10 mm)
- Environmental
  - Commercial temp. range (0°C to +70°C)
  - Industrial temp. range (-40°C to +85°C)
  - AEC-Q100 Grade 2 Automotive Qualified temp. range (-40°C to +105°C)

### Product Features

- Gigabit Ethernet PHY (LAN7430)
  - Auto-Negotiation and Auto-MDIX support
  - On-chip termination resistors for differential pairs
  - LinkMD® TDR-Based cable diagnostic to identify faulty copper cabling
  - Signal Quality Indicator
  - Quiet-WIRE® technology to reduce line emissions and enhance immunity for 100BASE-TX
  - Programmable LED Outputs for Link, Activity, Speed
  - Signal Quality Indicator (SQI) support
  - IEEE 802.3az Energy Efficient Ethernet (EEE)
- MAC with External Ethernet PHY (LAN7431)
  - RGMII supporting Internal Delay, Non-Internal Delay and Hybrid modes
  - MII supporting Fast Ethernet PHY
  - Flexibility to operate at 1.8V, 2.5V, or 3.3V
  - 9220 Byte Maximum Frame Size
- Gigabit Ethernet MAC includes
  - 10/100/1000Mbps half/full-duplex operation (only full-duplex operation at 1000Mbps)
  - Flow control with pause frame for full-duplex mode
  - 100/1000Mbps Low Power Idle for EEE
  - MDC/MDIO management for external PHY
  - RX frame, link status, EEE wakeup for WoL
- DMA Controller
  - Scatter-gather based for efficient data transfer to/from multiple on-chip RAM locations
  - Multi-channel for RX prioritization
- FIFO Controller
  - Utilize internal SRAMs to buffer RX and TX traffic between PCIe and Ethernet
  - TX LSO and TX Checksum Offload
- Receive Ethernet Packet Filtering
  - IP, TCP/UDP, L3, ICMP/IGMP Checksum offload
  - IEEE 802.1Q VLAN
  - Unicast, Multicast, Broadcast
  - Perfect / Hash Address
  - Priority based channel selection
  - Receive Side Scaling (RSS)
- PME Support
  - PCIe WAKE# and Beaconsing
  - PCIe PME Messaging
  - GPIO, Link Change, Ethernet Frame for wakeup
- EEPROM / OTP
  - External EEPROM support for MAC address and PCIe configuration
  - Integrated OTP memory for EEPROM displacement
- 1149.1 (JTAG) boundary scan

## TO OUR VALUED CUSTOMERS

It is our intention to provide our valued customers with the best documentation possible to ensure successful use of your Microchip products. To this end, we will continue to improve our publications to better suit your needs. Our publications will be refined and enhanced as new volumes and updates are introduced.

If you have any questions or comments regarding this publication, please contact the Marketing Communications Department via E-mail at [docerrors@microchip.com](mailto:docerrors@microchip.com). We welcome your feedback.

### Most Current Data Sheet

To obtain the most up-to-date version of this data sheet, please register at our Worldwide Web site at:

<http://www.microchip.com>

You can determine the version of a data sheet by examining its literature number found on the bottom outside corner of any page. The last character of the literature number is the version number, (e.g., DS30000000A is version A of document DS30000000).

### Errata

An errata sheet, describing minor operational differences from the data sheet and recommended workarounds, may exist for current devices. As device/documentation issues become known to us, we will publish an errata sheet. The errata will specify the revision of silicon and revision of document to which it applies.

To determine if an errata sheet exists for a particular device, please check with one of the following:

- Microchip's Worldwide Web site; <http://www.microchip.com>
- Your local Microchip sales office (see last page)

When contacting a sales office, please specify which device, revision of silicon and data sheet (include -literature number) you are using.

### Customer Notification System

Register on our web site at [www.microchip.com](http://www.microchip.com) to receive the most current information on all of our products.

## Table of Contents

1.0 Preface .....	4
2.0 Introduction .....	8
3.0 Pin Descriptions and Configuration .....	12
4.0 Power Connectivity .....	26
5.0 Device Configuration .....	30
6.0 Functional Descriptions .....	31
7.0 Operational Characteristics .....	48
8.0 Package Information .....	69
Appendix A: Data Sheet Revision History .....	73
Product Identification System .....	74
The Microchip Web Site .....	75
Customer Change Notification Service .....	75
Customer Support .....	75

# LAN7430/LAN7431

## 1.0 PREFACE

### 1.1 General Terms

**TABLE 1-1: GENERAL TERMS**

Term	Description
1000BASE-T	1 Gbps Ethernet over twisted pair, IEEE 802.3 compliant
100BASE-TX	100 Mbps Ethernet over twisted pair, IEEE 802.3 compliant
10BASE-T	10 Mbps Ethernet over twisted pair, IEEE 802.3 compliant
ADC	Analog-to-Digital Converter
AFE	Analog Front End
AN, ANEG	Auto-Negotiation
AOAC	Always on Always Connected
ARP	Address Resolution Protocol
BELT	Best Effort Latency Tolerance
BYTE	8-bits
CSMA/CD	Carrier Sense Multiple Access/Collision Detect
CSR	Control and Status Register
DA	Destination Address
DWORD	32-bits
EC	Embedded Controller
EEE	Energy Efficient Ethernet
FCS	Frame Check Sequence
FIFO	First In First Out buffer
FSM	Finite State Machine
FW	Firmware
GMII	Gigabit Media Independent Interface
GPIO	General Purpose I/O
HOST	External system (Includes processor, application software, etc.)
HW	Hardware. Refers to function implemented by digital logic.
IGMP	Internet Group Management Protocol
LDO	Linear Drop-Out Regulator
Level-Triggered Sticky Bit	This type of status bit is set whenever the condition that it represents is asserted. The bit remains set until the condition is no longer true, and the status bit is cleared by writing a zero.
LFSR	Linear Feedback Shift Register
LPM	Link Power Management
lsb	Least Significant Bit
LSB	Least Significant Byte
LTM	Latency Tolerance Messaging
MAC	Media Access Controller
MDI	Medium Dependent Interface
MDIX	Media Independent Interface with Crossover
MEF	Multiple Ethernet Frames
MII	Media Independent Interface
MLT-3	Multi-Level Transmission Encoding (3-Levels). A tri-level encoding method where a change in the logic level represents a code bit "1" and the logic output remaining at the same level represents a code bit "0".

**TABLE 1-1: GENERAL TERMS (CONTINUED)**

Term	Description
MSI / MSI-X	Message Signaled Interrupt
N/A	Not Applicable
OTP	One Time Programmable
PCS	Physical Coding Sublayer
PLL	Phase Locked Loop
PMIC	Power Management IC
POR	Power on Reset.
PTP	Precision Time Protocol
QWORD	64-bits
RESERVED	Refers to a reserved bit field or address. Unless otherwise noted, reserved bits must always be zero for write operations. Unless otherwise noted, values are not guaranteed when reading reserved bits. Unless otherwise noted, do not read or write to reserved addresses.
RGMI	Reduced Gigabit Media Independent Interface
RMII	Reduced Media Independent Interface
RMON	Remote Monitoring
SA	Source Address
SCSR	System Control and Status Registers
SEF	Single Ethernet Frame
SFD	Start of Frame Delimiter - The 8-bit value indicating the end of the preamble of an Ethernet frame
SMNP	Simple Network Management Protocol
TMII	Turbo Media Independent Interface
UDP	User Datagram Protocol - A connectionless protocol run on top of IP networks
WORD	16-bits

# LAN7430/LAN7431

## 1.2 Buffer Types

TABLE 1-2: BUFFER TYPE DESCRIPTIONS

Buffer	Description
AI	Analog input
AO	Analog output
AIO	Analog bi-directional
ICLK	Crystal oscillator input pin
OCLK	Crystal oscillator output pin
RGMI <sub>I</sub>	RGMI compliant input
RGMI <sub>O</sub>	RGMI compliant output
IS	Input with Schmitt trigger
OD4	Open-drain output with 4 mA sink
VIS	Variable voltage input with Schmitt trigger
VO8	Variable voltage output with 8 mA sink and 8 mA source
VOD8	Variable voltage open-drain output with 8 mA sink
VO12	Variable voltage output with 12 mA sink and 12 mA source
VOD12	Variable voltage open-drain output with 12 mA sink
VOS12	Variable voltage open-source output with 12 mA source
PU	<p>Internal pull-up with 47<math>\mu</math>A (typical @ 3.3V). Unless otherwise noted in the pin description, internal pull-ups are always enabled.</p> <p>Internal pull-up resistors prevent unconnected inputs from floating. Do not rely on internal resistors to drive signals external to the device. When connected to a load that must be pulled high, an external resistor must be added.</p>
PD	<p>Internal pull-down with 47<math>\mu</math>A (typical @ 3.3V). Unless otherwise noted in the pin description, internal pull-downs are always enabled.</p> <p>Internal pull-down resistors prevent unconnected inputs from floating. Do not rely on internal resistors to drive signals external to the device. When connected to a load that must be pulled low, an external resistor must be added.</p>
P	Power pin

## 1.3 Register Bit Types

Table 1-3 describes the register bit attributes used throughout this document.

**TABLE 1-3: REGISTER BIT TYPES**

Register Bit Type Notation	Register Bit Description
R	<b>Read:</b> A register or bit with this attribute can be read.
W	<b>Write:</b> A register or bit with this attribute can be written.
RO	<b>Read only:</b> Read only. Writes have no effect.
WO	<b>Write only:</b> If a register or bit is write-only, reads will return unspecified data.
W1S	<b>Write One to Set:</b> Writing a one sets the value. Writing a zero has no effect.
W1C	<b>Write One to Clear:</b> Writing a one clears the value. Writing a zero has no effect.
WAC	<b>Write Anything to Clear:</b> Writing anything clears the value.
RC	<b>Read to Clear:</b> Contents is cleared after the read. Writes have no effect.
LL	<b>Latch Low:</b> Clear on read of register.
LH	<b>Latch High:</b> Clear on read of register.
SC	<b>Self-Clearing:</b> Contents is self-cleared after being set. Writes of zero have no effect. Contents can be read.
RO/LH	<b>Read Only, Latch High:</b> This mode is used by the Ethernet PHY registers. Bits with this attribute will stay high until the bit is read. After it a read, the bit will remain high, but will change to low if the condition that caused the bit to go high is removed. If the bit has not been read the bit will remain high regardless of if its cause has been removed.
NALR	<b>Not Affected by Lite Reset.</b> The state of NALR bits does not change on assertion of a lite reset.
NASR	<b>Not Affected by Software Reset.</b> The state of NASR bits does not change on assertion of a software reset.
STKY	This field is "Sticky" in that it is neither initialized nor modified by hot reset or Function Level Reset.
RESERVED	<b>Reserved Field:</b> Reserved fields must be written with zeros, unless otherwise indicated, to ensure future compatibility. The value of reserved bits is not guaranteed on a read.

## 1.4 Reference Documents

1. *IEEE 802.3<sup>TM</sup>-2015 IEEE Standard for Ethernet*, <http://standards.ieee.org/about/get/802/802.3.html>
2. *IEEE 802.1D<sup>TM</sup>-2004 IEEE Standard for Local and Metropolitan Area Networks - Media Access Control (MAC) Bridges*, <http://standards.ieee.org/about/get/802/802.1.html>
3. *IEEE 802.1Q<sup>TM</sup>-2014 IEEE Standard for Local and Metropolitan Area Networks - Bridges and Bridged Networks*, <http://standards.ieee.org/about/get/802/802.1.html>
4. *IEEE 1149.1-2013 IEEE Standard for Test Access Port and Boundary-Scan Architecture*, <https://standards.ieee.org/findstds/standard/1149.1-2013.html>
5. *IEEE 1588-2008 IEEE Standard for Precision Clock Synchronization Protocol for Networked Measurement and Control Systems*, <https://standards.ieee.org/findstds/standard/1588-2008.html>
6. *Reduced Gigabit Media Independent Interface (RGMI) Specification Version 2.0*, [https://web.archive.org/web/20160303171328/http://www.hp.com/rnd/pdfs/RGMIiv2\\_0\\_final\\_hp.pdf](https://web.archive.org/web/20160303171328/http://www.hp.com/rnd/pdfs/RGMIiv2_0_final_hp.pdf)
7. *PCI Express® Base Specification Revision 3.1a*, <https://pcisig.com/specifications>
8. *PCI Bus Power Management Interface Specification Revision 1.2*, <https://pcisig.com/specifications>

# LAN7430/LAN7431

## 2.0 INTRODUCTION

### 2.1 General Description

The LAN7430/LAN7431 is a highly integrated PCIe to Gigabit Ethernet Controller, with IEEE Std 1588™-2008 and advanced power management features, that provides a high performance and cost effective PCIe/Ethernet bridging solution for automotive and industrial applications.

The PCIe 3.1 PHY supports 1 Lane at 2.5GT/s for chip-to-chip and card-to-card connectivity across a combination of printed circuit boards, connectors, backplane wirings, and cables.

The LAN7430 has an integrated 10/100/1000 Ethernet PHY port with IEEE 802.3az Energy Efficient Ethernet (EEE) and 10BASE-T<sub>e</sub> support, while the LAN7431 supports either a RGMII (v1.3 and v2.0) or a MII MAC port for direct connectivity to transceivers, such as 100BASE-T1 or HDBaseT.

The LAN7430/LAN7431 further integrates PCIe Endpoint Controller, DMA Controller, Receive Filtering Engine, FIFO Controller, Ethernet MAC, EEPROM Controller, OTP Memory, TAP Controller, PME, and Clock/Reset/Power Management functions.

The IEEE1588-2008 PTP functions provide hardware support for the IEEE Std 1588-2008 (v2) Precision Time Protocol (PTP), allowing clock synchronization with remote Ethernet devices, packet time stamping, and time driven event generation. The device may function as a master or a slave clock per the IEEE Std 1588-2008 specification. End-to-end and peer-to-peer link delay mechanisms are supported as are one-step and two-step operations.

Power Management functions include:

- Enabling the host to place the device in a reduced power state, by selectively disabling internal clocks, placing it into EEE Low Power Idle mode, and powering down the Ethernet PHY (LAN7430 only).
- Providing for detection of various wakeup events.
- Providing a host-readable READY flag which is set when the device is fully operational.
- Controlling the loading of OTP or EEPROM values after a system reset.
- Supporting D0 and D3<sub>hot</sub> and D3<sub>cold</sub> states
- Supporting L0s, L1 states and L1.1 and L1.2 Sub-states

Single 3.3V supply operation is achieved by enabling the on-chip Switching and LDO Regulators to supply the core and I/O voltages.

An internal EEPROM controller exists to load PCIe and MAC Address configuration parameters. For EEPROM-less applications, the LAN7430/LAN7431 provides 1K Bytes of OTP memory that can be used to preload this same configuration data before enumeration.

The integrated IEEE 1149.1 compliant TAP controller provides boundary scan via JTAG.

Device specific features that do not pertain to the entire LAN7430/LAN7431 family are called out independently throughout this document. [Table 2-1](#) provides a summary of the feature differences between family members:

**TABLE 2-1: LAN7430/LAN7431 FAMILY FEATURE MATRIX**

Part Number	Package	Integrated PCIe PHY	Integrated PCIe Endpoint Controller	Integrated Gigabit Ethernet PHY	Integrated Gigabit Ethernet MAC	MIIM Support	RGMII Support	IEEE 1588-2008	Commercial Temp. (0° to 70°C)	Industrial Temp. (-40° to 85°C)	Automotive Temp. (-40° to 105°C)
LAN7430	48-SQFN	X	X	X	X			X	X	X	X
LAN7431	72-SQFN	X	X		X	X	X	X	X	X	X



# LAN7430/LAN7431

An internal block diagram of the LAN7430/LAN7431 is shown in [Figure 2-1](#).

**FIGURE 2-1: LAN7430/LAN7431 BLOCK DIAGRAM**

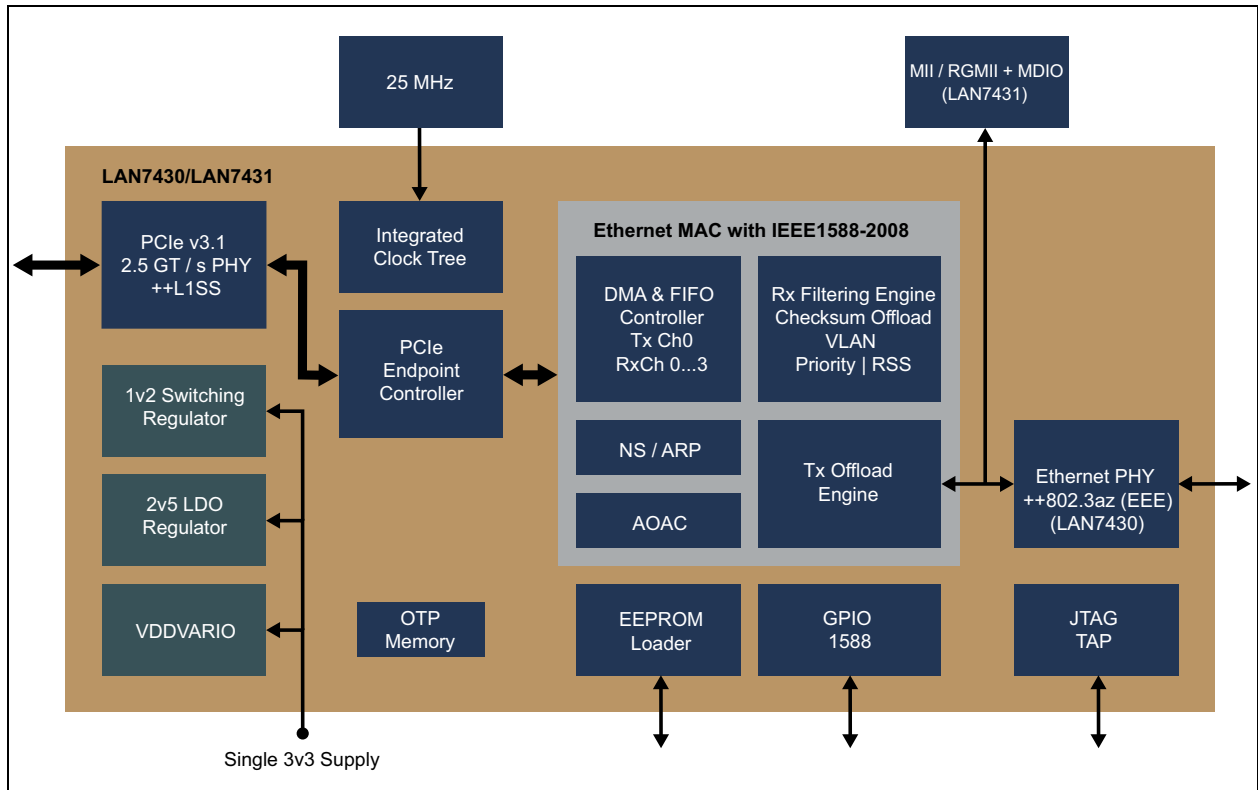

The following system-level block diagrams detail the LAN7430/LAN7431 in typical applications.

# LAN7430/LAN7431

Figure 2-2 details the LAN7430's integrated Ethernet PHY port connected across a backplane to an application processor.

FIGURE 2-2: LAN7430 CONNECTED ACROSS BACKPLANE TO APPLICATION PROCESSOR

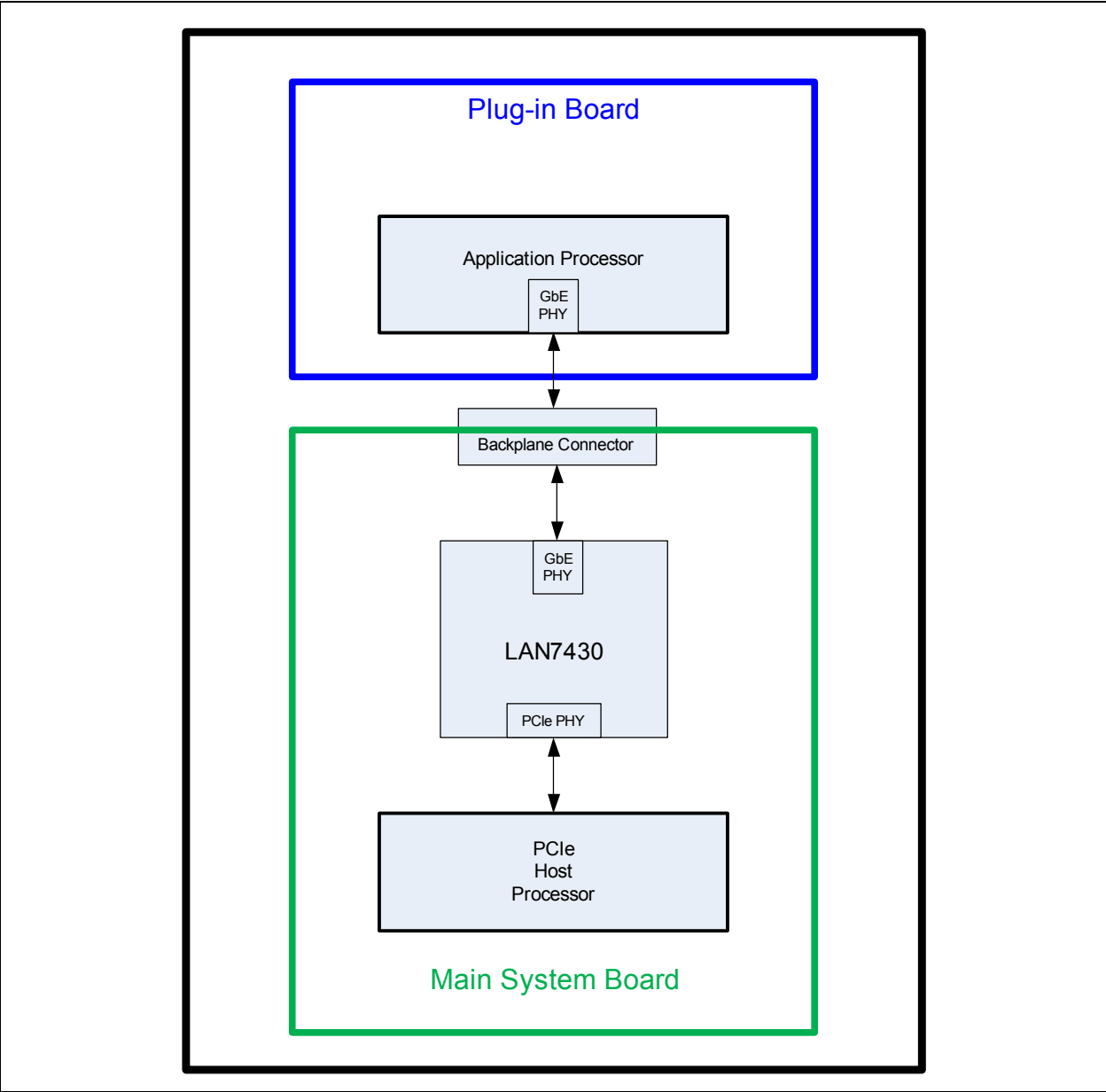
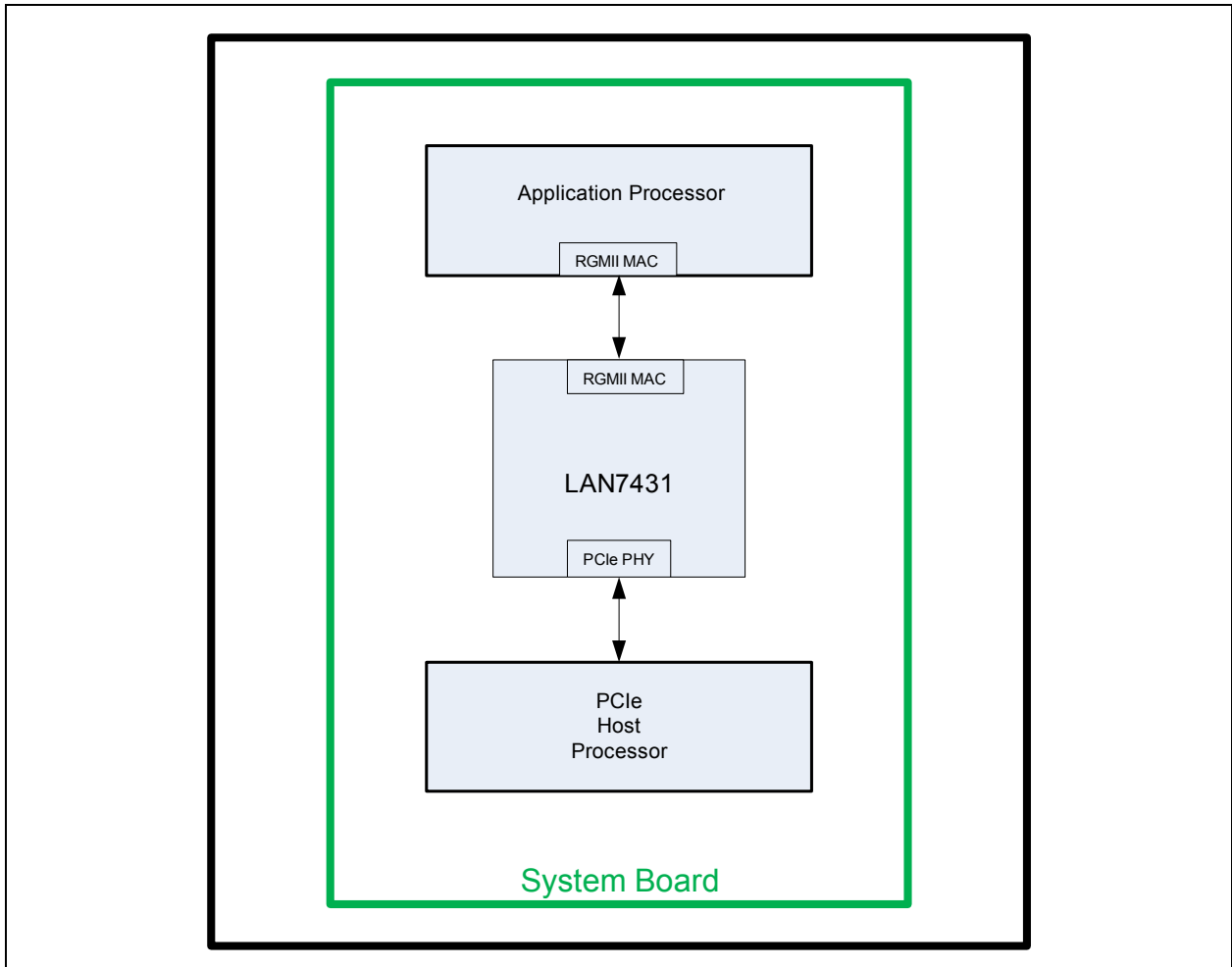

Figure 2-3 details the LAN7431's RGMII MAC port connected to the RGMII MAC of an application processor.

**FIGURE 2-3: LAN7431 CONNECTED VIA RGMII TO APPLICATION PROCESSOR**



# LAN7430/LAN7431

## 3.0 PIN DESCRIPTIONS AND CONFIGURATION

The pin assignments for the LAN7430 are detailed in [Section 3.1, "LAN7430 Pin Assignments"](#). The pin assignments for the LAN7431 are detailed in [Section 3.2, "LAN7431 Pin Assignments"](#). Pin descriptions are provided in [Section 3.3, "Pin Descriptions"](#).

### 3.1 LAN7430 Pin Assignments

The device pin diagram for the LAN7430 can be seen in [Figure 3-1](#). [Table 3-1](#) provides a LAN7430 pin assignments table. Pin descriptions are provided in [Section 3.3, "Pin Descriptions"](#).

**FIGURE 3-1: LAN7430 PIN ASSIGNMENTS**

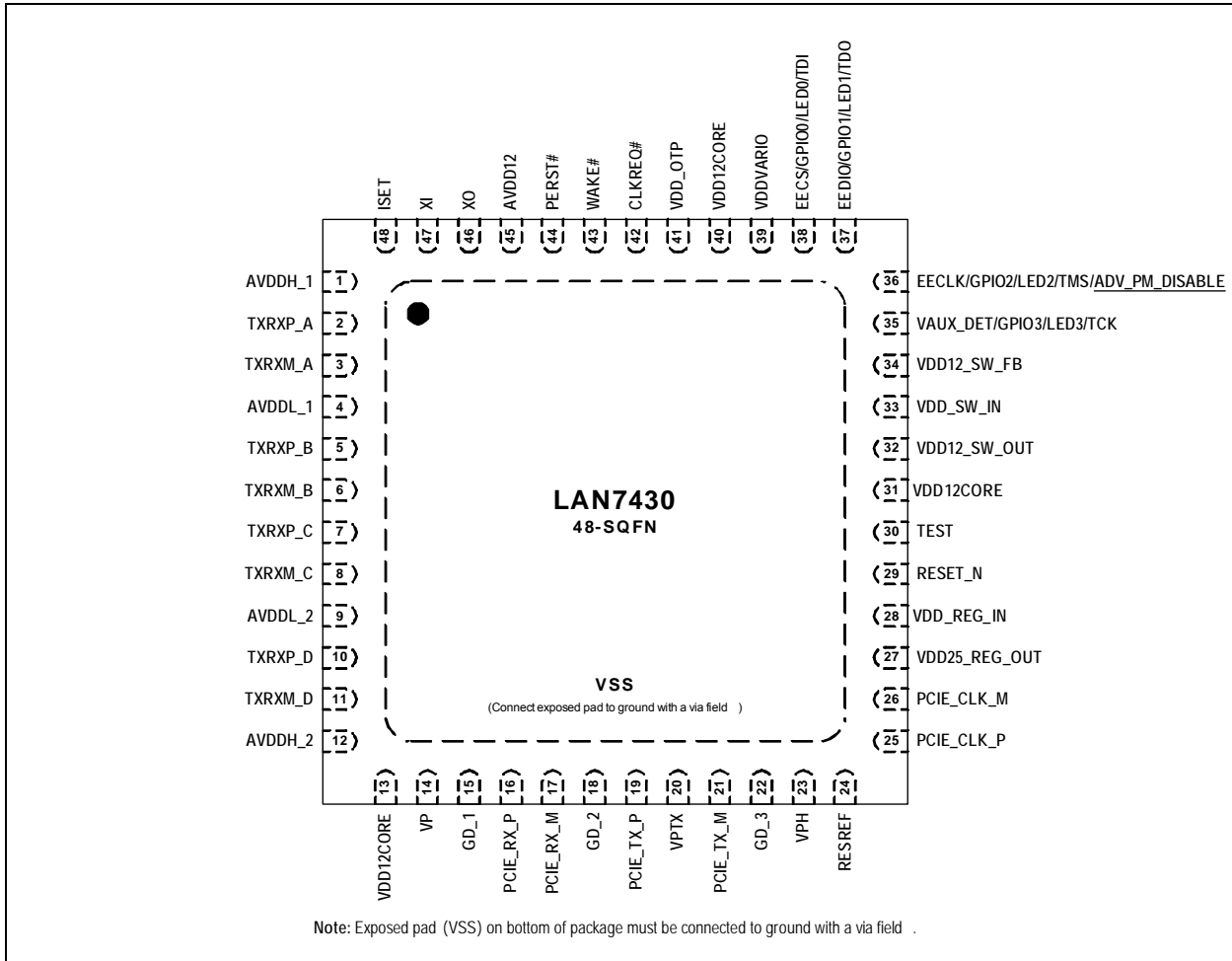

**Note:** Configuration straps are identified by an underlined symbol name. Signals that function as configuration straps must be augmented with an external resistor when connected to a load.

# LAN7430/LAN7431

**TABLE 3-1: LAN7430 PIN ASSIGNMENTS**

Pin	Pin Name	Pin	Pin Name
1	AVDDH_1	25	PCIE_CLK_P
2	TXRXP_A	26	PCIE_CLK_M
3	TXRXM_A	27	VDD25_REG_OUT
4	AVDDL_1	28	VDD_REG_IN
5	TXRXP_B	29	RESET_N
6	TXRXM_B	30	TEST
7	TXRXP_C	31	VDD12CORE
8	TXRXM_C	32	VDD12_SW_OUT
9	AVDDL_2	33	VDD_SW_IN
10	TXRXP_D	34	VDD12_SW_FB
11	TXRXM_D	35	VAUX_DET/GPIO3/LED3/TCK
12	AVDDH_2	36	EECLK/GPIO2/LED2/TMS/ ADV_PM_DISABLE
13	VDD12CORE	37	EEDIO/GPIO1/LED1/TDO
14	VP	38	EECS/GPIO0/LED0/TDI
15	GD_1	39	VDDVARIO
16	PCIE_RX_P	40	VDD12CORE
17	PCIE_RX_M	41	VDD_OTP
18	GD_2	42	CLKREQ#
19	PCIE_TX_P	43	WAKE#
20	VPTX	44	PERST#
21	PCIE_TX_M	45	AVDD12
22	GD_3	46	XO
23	VPH	47	XI
24	RESREF	48	ISSET
Exposed Pad (VSS) must be connected to ground.			

# LAN7430/LAN7431

## 3.2 LAN7431 Pin Assignments

The device pin diagram for the LAN7431 can be seen in [Figure 3-2](#). [Table 3-2](#) provides a LAN7431 pin assignments table. Pin descriptions are provided in [Section 3.3, "Pin Descriptions"](#).

**FIGURE 3-2: LAN7431 PIN ASSIGNMENTS**

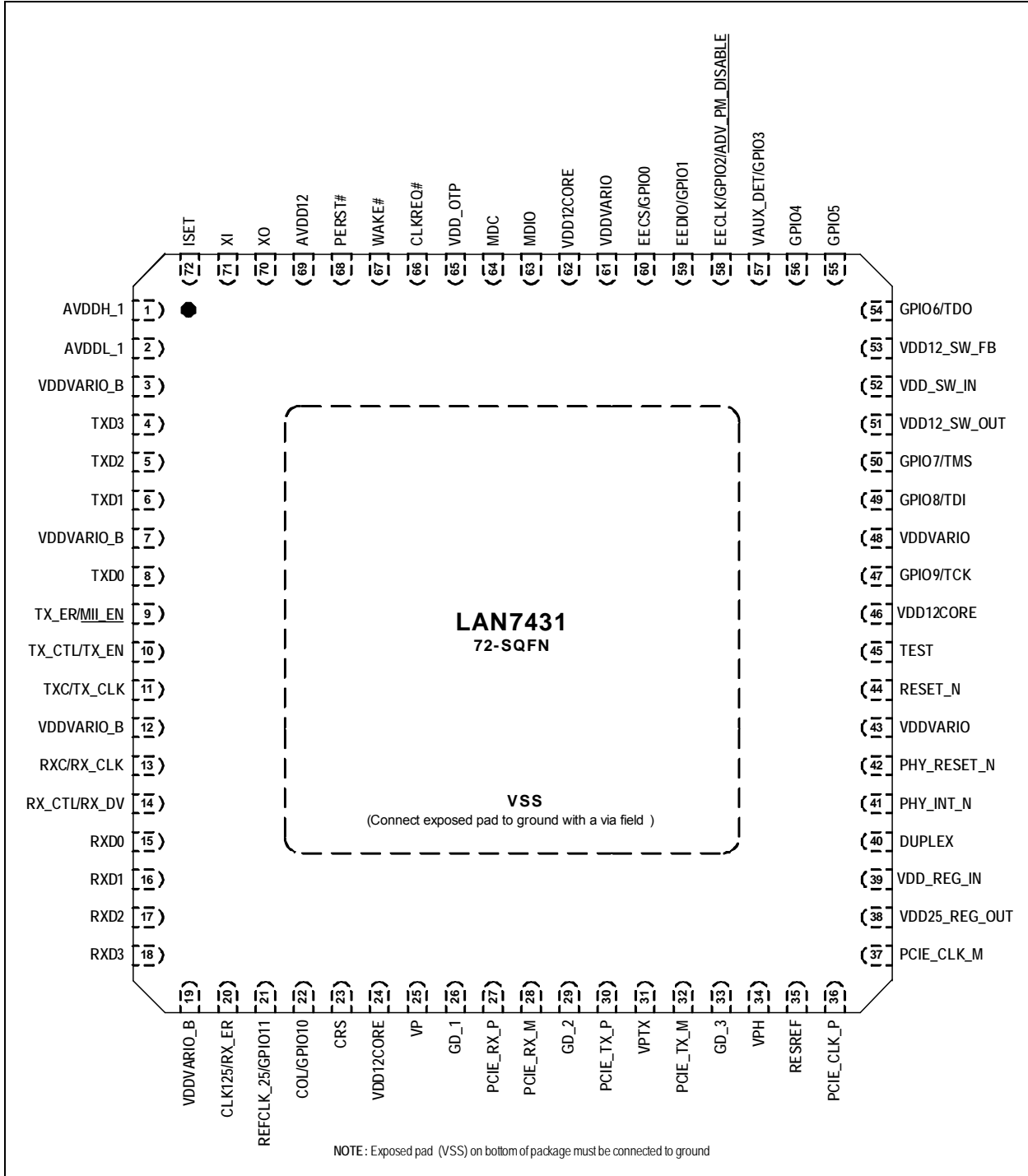

**Note:** Configuration straps are identified by an underlined symbol name. Signals that function as configuration straps must be augmented with an external resistor when connected to a load.

# LAN7430/LAN7431

**TABLE 3-2: LAN7431 PIN ASSIGNMENTS**

Pin	Pin Name	Pin	Pin Name
1	AVDDH_1	37	PCIE_CLK_M
2	AVDDL_1	38	VDD25_REG_OUT
3	VDDVARIO_B	39	VDD_REG_IN
4	TXD3	40	DUPLEX
5	TXD2	41	PHY_INT_N
6	TXD1	42	PHY_RESET_N
7	VDDVARIO_B	43	VDDVARIO
8	TXD0	44	RESET_N
9	TX_ER/MII_EN	45	TEST
10	TX_CTL/TX_EN	46	VDD12CORE
11	TXC/TX_CLK	47	GPIO9/TCK
12	VDDVADIO_B	48	VDDVARIO
13	RXC/RX_CLK	49	GPIO8/TDI
14	RX_CTL/RX_DV	50	GPIO7/TMS
15	RXD0	51	VDD12_SW_OUT
16	RXD1	52	VDD_SW_IN
17	RXD2	53	VDD12_SW_FB
18	RXD3	54	GPIO6/TDO
19	VDDVARIO_B	55	GPIO5
20	CLK125/RX_ER	56	GPIO4
21	REFCLK_25/GPIO11	57	VAUX_DET/GPIO3
22	COL/GPIO10	58	EECLK/GPIO2/ADV_PM_DISABLE
23	CRS	59	EEDIO/GPIO1
24	VDD12CORE	60	EECS/GPIO0
25	VP	61	VDDVARIO
26	GD_1	62	VDD12CORE
27	PCIE_RX_P	63	MDIO
28	PCIE_RX_M	64	MDC
29	GD_2	65	VDD_OTP
30	PCIE_TX_P	66	CLKREQ#
31	VPTX	67	WAKE#
32	PCIE_TX_M	68	PERST#
33	GD_3	69	AVDD12
34	VPH	70	XO
35	RESREF	71	XI
36	PCIE_CLK_P	72	ISSET

Exposed Pad (VSS) must be connected to ground.

# LAN7430/LAN7431

## 3.3 Pin Descriptions

This section provides descriptions of each individual pin function. Buffer type definitions are detailed in [Table 1-2](#).

**TABLE 3-3: PIN DESCRIPTIONS**

Name	Symbol	Buffer Type	Description
Gigabit Ethernet PHY Interface (LAN7430 only)			
Ethernet TX/RX Positive Channel A	TXRXP_A	AIO	Media Dependent Interface[0], positive signal of differential pair  1000BT mode: TXRXP_A corresponds to BI_DA+ for MDI configuration and BI_DB+ for MDI-X configuration, respectively.  10BT/100BT mode: TXRXP_A is the positive transmit signal (TX+) for MDI configuration and the positive receive signal (RX+) for MDI-X configuration, respectively.
Ethernet TX/RX Negative Channel A	TXRXM_A	AIO	Media Dependent Interface[0], negative signal of differential pair  1000BT mode: TXRXM_A corresponds to BI_DA- for MDI configuration and BI_DB- for MDI-X configuration, respectively.  10BT/100BT-TX mode: TXRXM_A is the negative transmit signal (TX-) for MDI configuration and the negative receive signal (RX-) for MDI-X configuration, respectively.
Ethernet TX/RX Positive Channel B	TXRXP_B	AIO	Media Dependent Interface[1], positive signal of differential pair  1000BT mode: TXRXP_B corresponds to BI_DB+ for MDI configuration and BI_DA+ for MDI-X configuration, respectively.  10BT/100BT mode: TXRXP_B is the positive receive signal (RX+) for MDI configuration and the positive transmit signal (TX+) for MDI-X configuration, respectively.
Ethernet TX/RX Negative Channel B	TXRXM_B	AIO	Media Dependent Interface[1], negative signal of differential pair  1000BT mode: TXRXM_B corresponds to BI_DB- for MDI configuration and BI_DA- for MDI-X configuration, respectively.  10BT/100BT mode: TXRXP_B is the negative receive signal (RX-) for MDI configuration and the negative transmit signal (TX-) for MDI-X configuration, respectively.
Ethernet TX/RX Positive Channel C	TXRXP_C	AIO	Media Dependent Interface[2], positive signal of differential pair  1000BT mode: TXRXP_C corresponds to BI_DC+ for MDI configuration and BI_DD+ for MDI-X configuration, respectively.  10BT/100BT mode: TXRXP_C is not used.



# LAN7430/LAN7431

**TABLE 3-3: PIN DESCRIPTIONS (CONTINUED)**

Name	Symbol	Buffer Type	Description
Ethernet TX/RX Negative Channel C	TXRXM_C	AIO	Media Dependent Interface[2], negative signal of differential pair  1000BT mode: TXRXM_C corresponds to BI_DC- for MDI configuration and BI_DD- for MDI-X configuration, respectively.  10BT/100BT mode: TXRXM_C is not used.
Ethernet TX/RX Positive Channel D	TXRXP_D	AIO	Media Dependent Interface[3], positive signal of differential pair  1000BT mode: TXRXP_D corresponds to BI_DD+ for MDI configuration and BI_DC+ for MDI-X configuration, respectively.  10BT/100BT mode: TXRXP_D is not used.
Ethernet TX/RX Negative Channel D	TXRXM_D	AIO	Media Dependent Interface[3], negative signal of differential pair  1000BT mode: TXRXM_D corresponds to BI_DD- for MDI configuration and BI_DC- for MDI-X configuration, respectively.  10BT/100BT mode: TXRXM_D is not used.
External Gigabit Ethernet PHY RGMII (LAN7431 only)			
Transmit Data	TXD3 TXD2 TXD1 TXD0	RGMII_O	The MAC transmits data to the external Ethernet PHY using these signals.
Transmit Control	TX_CTL	RGMII_O	Indicates both the transmit data enable (TXEN) and transmit error (TXER) functions per the RGMII specification.
RGMII Transmit Clock	TXC	RGMII_O	Used to latch data from the MAC into the external Ethernet PHY in RGMII mode.  1000BASE-T: 125MHz 100BASE-TX: 25MHz 10BASE-T: 2.5MHz
Receive Data	RXD3 RXD2 RXD1 RXD0	RGMII_I	The external Ethernet PHY transfers data to the MAC using these signals.
Receive Control	RX_CTL	RGMII_I	Indicates both the receive data valid (RXDV) and receive error (RXER) functions per the RGMII specification.
RGMII Receive Clock	RXC	RGMII_I	Used to transfer data from the external Ethernet PHY to the MAC in RGMII mode.  1000BASE-T: 125MHz 100BASE-TX: 25MHz 10BASE-T: 2.5MHz
25 MHz Reference Clock	REFCLK_25	VO12	25 MHz reference clock to be provided to and used as a reference by the external Gigabit Ethernet PHY.

# LAN7430/LAN7431

**TABLE 3-3: PIN DESCRIPTIONS (CONTINUED)**

Name	Symbol	Buffer Type	Description
CLK125 MHz	CLK125	VIS	Used as an input from external Ethernet PHY. This signal may be used by the controller to generate the RGMII TX clock.
PHY Interrupt	PHY_INT_N	VIS	Interrupt from external Ethernet PHY.
PHY Reset	PHY_RESET_N	VO12	Reset to external Ethernet PHY.
Duplex Mode	DUPLEX	VIS	Duplex Mode. This signal connects to the Duplex Mode output from external Ethernet PHY.  When set the external Ethernet PHY is in Full Duplex mode.  <b>Note:</b> If the Ethernet PHY does not have a duplex output signal, then it is recommended that this signal should be tied to <b>VDDVARIO</b> to force full duplex operation
Management Interface Data	MDIO	VIS/ VO8 (PU)	This is the management data to/from an external Ethernet PHY.  <b>Note:</b> An external pull-up is required when the MII management interface is used, to ensure that the IDLE state of the MDIO signal is a logic one.  <b>Note:</b> An external pull-up is recommended when the MII management interface is not used, to avoid a floating signal.
Management Interface Clock	MDC	VO8	This is the management clock output to an external Ethernet PHY
External Fast Ethernet PHY MII (LAN7431 only)			
Transmit Data	TXD3 TXD2 TXD1 TXD0	VO12	The MAC transmits data to the external Ethernet PHY using these signals.
Transmit Enable	TX_EN	VO12	Indicates the presence of valid data on TXD[3:0]
Transmit Error	TX_ER	VO12	Indicates a transmit error condition.
Transmit Clock	TX_CLK	VIS	Used to transfer data from the MAC to the external Ethernet PHY in MII mode.  100BASE-TX: 25MHz 10BASE-T: 2.5MHz
Collision Detect	COL	VIS	Asserted by external Ethernet PHY to indicate detection of a collision condition.  <b>Note:</b> Used in half-duplex mode only.
Carrier Sense	CRS	VIS	Indicates detection of carrier by external Ethernet PHY.  <b>Note:</b> Used in half-duplex mode only.
Receive Data	RXD3 RXD2 RXD1 RXD0	VIS	The external Ethernet PHY transfers data to the MAC using these signals.
Receive Data Valid	RX_DV	VIS	Indicates that recovered and decoded data is being presented on the receive data pins.

# LAN7430/LAN7431

**TABLE 3-3: PIN DESCRIPTIONS (CONTINUED)**

Name	Symbol	Buffer Type	Description
Receive Error	RX_ER	VIS	Asserted to indicate an error has been detected in the frame presently being transferred from the external Ethernet PHY.
Receive Clock	RX_CLK	VIS	Used to transfer data from the external Ethernet PHY to the MAC in MII mode.  100BASE-TX: 25MHz 10BASE-T: 2.5MHz
25 MHz Reference Clock	REFCLK_25	VO12	25 MHz reference clock to be provided to and used as a reference by the external Fast Ethernet PHY.
PHY Interrupt	PHY_INT_N	VIS	Interrupt from external Ethernet PHY.
PHY Reset	PHY_RESET_N	VO12	Reset to external Ethernet PHY.
Duplex Mode	DUPLEX	VIS	Duplex Mode. This signal connects to the Duplex Mode output from external Ethernet PHY.  When set the external Ethernet PHY is in Full Duplex mode.  <b>Note:</b> If the external Ethernet PHY does not have a duplex output signal, then it is recommended that this signal should be tied to <a href="#">VDDVARIO</a> to force full duplex operation
Management Interface Data	MDIO	VIS/ VO8 (PU)	This is the management data to/from an external Ethernet PHY.  <b>Note:</b> An external pull-up is required when the MII management interface is used, to ensure that the IDLE state of the MDIO signal is a logic one.  <b>Note:</b> An external pull-up is recommended when the MII management interface is not used, to avoid a floating signal.  <b>APPLICATION NOTE:</b> A pull-up (internal or external) will result in a return value of FFFFh when a non-existent or non-addressed PHY is read. If a value of 0000h is desired instead, a pull-down may be used.
Management Interface Clock	MDC	VO8	This is the management clock output to an external Ethernet PHY
PCIe			
TX Positive	PCIE_TX_P	AO	PCIe Serial Data Output positive.  Serial differential output link in the PCIe interface running at 2.5 GT/s.  A series capacitor in the range of 100nF to 200nF is required.

# LAN7430/LAN7431

**TABLE 3-3: PIN DESCRIPTIONS (CONTINUED)**

Name	Symbol	Buffer Type	Description
TX Negative	PCIE_TX_M	AO	<p>PCIe Serial Data Output negative.</p> <p>Serial differential output link in the PCIe interface running at 2.5 GT/s.</p> <p>A series capacitor in the range of 100nF to 200nF is required.</p>
RX Positive	PCIE_RX_P	AI	<p>PCIe Serial Data Input positive.</p> <p>Serial differential input link in the PCIe interface running at 2.5 GT/s.</p>
RX Negative	PCIE_RX_M	AI	<p>PCIe Serial Data Input negative.</p> <p>Serial differential input link in the PCIe interface running at 2.5 GT/s.</p>
External Reference Clock Positive	PCIE_CLK_P	AI	<p>PCIe Differential Reference Clock In positive</p> <p>This pin receives a 100 MHz differential clock input.</p>
External Reference Clock Negative	PCIE_CLK_M	AI	<p>PCIe Differential Reference Clock In negative</p> <p>This pin receives a 100 MHz differential clock input.</p>
External Reference Resistor	RESREF	AI	<p>This pin should be connect to ground through a 200 ohm 1% 100 ppm / C resistor.</p>
Wake up	WAKE#	IS / OD4	<p>Wake</p> <p>This signal is driven low when the device detects a wakeup.</p> <p>In OBFF mode, OBFF events are signaled using the <b>WAKE#</b> pin as an input.</p> <p><b>Note:</b> When the device is powered down, this pin is isolated from the PCIe bus and does not present any significant loading or provide any drive.</p>
PCIe Reset	PERST#	IS	<p>Power and Clock Good Indication</p> <p>The <b>PERST#</b> signal indicates that both PCIe power and clock are available.</p> <p><b>Note:</b> When the device is powered down, this pin is isolated from the PCIe bus and does not present any significant loading or provide any drive.</p>
Clock Request	CLKREQ#	IS / OD4	<p>Clock Request</p> <p>The <b>CLKREQ#</b> signal is used to power manage the Link clock. It is also used for L1 power management Sub state control.</p> <p><b>Note:</b> When the device is powered down, this pin is isolated from the PCIe bus and does not present any significant loading or provide any drive.</p>

# LAN7430/LAN7431

**TABLE 3-3: PIN DESCRIPTIONS (CONTINUED)**

Name	Symbol	Buffer Type	Description
Auxiliary Voltage Detect	VAUX_DET	VIS (PD)	<p>Auxiliary Voltage Detection</p> <p>The <b>VAUX_DET</b> is used to indicate when PME from D3<sub>cold</sub> is supported.</p> <p>When tied to VSS, PME from D3<sub>cold</sub> is not supported. The weak pull-down will create a logic low when plugged into a system board that does not support the delivery of the auxiliary voltage (the auxiliary voltage connection is floating).</p> <p>When the device is powered exclusively from auxiliary voltage, this pin is tied to the auxiliary voltage (3.3V) to indicate PME from D3<sub>cold</sub> is supported.</p> <p>When the device is powered from a multiplexed main voltage / auxiliary voltage, this pin is tied to the auxiliary voltage (3.3V) to indicate PME from D3<sub>cold</sub> is supported and to monitor the presence of the auxiliary voltage.</p> <p><b>Note:</b> If alternate usage of this pin (<b>GPIO3</b>, <b>LED3</b> or <b>TCK</b>) is enabled, the pull-down is disabled and the input value of the pin is overridden to a low value.</p> <p>Since this pin is shared with <b>GPIO3</b>, <b>LED3</b> and <b>TCK</b>, a series resistor is recommended to prevent an accidental conflict with the auxiliary voltage. This resistor must be low enough in value to override the on chip pull-down.</p>
Crystal / Oscillator / External Reference Clock			
Crystal / Oscillator / External Reference Clock Input	XI	ICLK	<p>When using a 25MHz crystal, this input is connected to one lead of the crystal.</p> <p>When using a 3.3V oscillator or external reference clock, this is the input from the clock source.</p> <p>The crystal, oscillator, or external reference clock should have a tolerance of <math>\pm 50</math>ppm.</p>
Crystal Output	XO	OCLK	<p>When using a 25MHz crystal, this output is connected to one lead of the crystal.</p> <p>When using an oscillator or external clock source, this pin is not connected.</p>
EEPROM			
EEPROM Chip Select	EECS	VO12 (PD)	<p>This pin drives the chip select input of the external EEPROM.</p> <p><b>Note:</b> The internal pull-down holds a low on the output pin during reset.</p>

# LAN7430/LAN7431

**TABLE 3-3: PIN DESCRIPTIONS (CONTINUED)**

Name	Symbol	Buffer Type	Description
EEPROM Data In / Out	EEDIO	VIS / VO12 (PD)	This bidirectional pin is used for the EEPROM data. This pin directly drives the data input of the external EEPROM. The data output of the external EEPROM drives this pin through an external resistor.  <b>Note:</b> The internal pull-down holds a low on the pin during reset and provides a low on the input if an EEPROM is not connected.  <b>Note:</b> An external resistor, on the EEPROM's data output, must be used to prevent contention during data read operations.
EEPROM Clock	EECLK	VO12 (PD)	This pin drives the clock input of the external EEPROM.  <b>Note:</b> The internal pull-down holds a low on the output pin during reset.
Miscellaneous			
General Purpose I/O x	GPIO0 GPIO1 GPIO2 GPIO3 GPIO4 GPIO5 GPIO6 GPIO7 GPIO8 GPIO9 GPIO10 GPIO11	VIS/ VO8/ VOD8 (PU)	Each of these general purpose I/O pins is fully programmable as either a push-pull output, an open-drain output, or a Schmitt-triggered input with pull-up.  <b>Note:</b> The pull-up is only enabled if the pin is set as a GPIO.  <b>Note:</b> <b>GPIO0</b> through <b>GPIO3</b> are available for the LAN7430 and LAN7431.  <b>Note:</b> <b>GPIO4</b> through <b>GPIO11</b> are available only for the LAN7431.
Test Pin	TEST	VIS (PD)	This pin is used to enable test modes and must be connected to ground for proper functional operation.
System Reset	RESET_N	VIS	System reset. This pin is active low.  <b>Note:</b> If this signal is unused it must be pulled up to <a href="#">VDDVARIO</a> .
Indicator LEDs	LED0 LED1 LED2 LED3	VOD12 VOS12	(LAN7430 only) LED signal sourced from Gigabit Ethernet PHY.  <b>Note:</b> When enabled as LED outputs, the pins are either open-Drain or open-Source drivers.
External PHY Bias Resistor	ISET	AI	This pin should be connect to ground through a 6.04K 1% resistor.
JTAG			
JTAG Test Mux Select	TMS	VIS	JTAG test mode select.
JTAG Test Clock	TCK	VIS	JTAG test clock.  <b>Note:</b> The maximum operating frequency of this clock is half of the system clock.
JTAG Test Data Input	TDI	VIS	JTAG data input
JTAG Test Data Output	TDO	VO12	JTAG data output.

**TABLE 3-3: PIN DESCRIPTIONS (CONTINUED)**

Name	Symbol	Buffer Type	Description
Configuration Straps			
MII Enable Configuration Strap	MII_EN	VIS (PD)	<p>(LAN7431 only) When pulled high, the port operates in MII mode. When pulled low or floated, the port operates in RGMII mode. See <a href="#">Section 3.4, "Configuration Straps"</a> for additional information.</p> <p><b>Note:</b> The internal pull-down is disabled once the strap is latched.</p> <p><b>Note:</b> If an external pull-up is used, it should be connected to <a href="#">VDDVARIO_B</a>.</p>
Advance Power Management Disable Configuration Strap	ADV_PM_DISABLE	VIS (PD)	<p>When pulled high, the following bits default low. When pulled low or floated, the register bits default high.</p> <ul style="list-style-type: none"> <li>• Clock Power Management in Link Capabilities</li> <li>• L1 PM Substates Supported in L1 PM Substates Capabilities</li> <li>• ASPM L1.1 Supported in L1 PM Substates Capabilities</li> <li>• ASPM L1.2 Supported in L1 PM Substates Capabilities</li> <li>• PCI-PM L1.1 Supported in L1 PM Substates Capabilities</li> <li>• PCI-PM L1.2 Supported in L1 PM Substates Capabilities</li> </ul> <p><b>Note:</b> Regardless of the strap default, the bits may be loaded from OTP or EEPROM. The default is used in the absence of a programmed OTP or EEPROM.</p> <p><b>Note:</b> The internal pull-down is disabled once the strap is latched.</p> <p><b>Note:</b> If an external pull-up is used, it should be connected to <a href="#">VDDVARIO</a>.</p>
Power / Ground			
Ethernet PHY +1.2V Analog Power Supply	AVDD12	P	1.2V power for PLL/DLL
Ethernet PHY +2.5V / 3.3V Analog Power Supply	AVDDH_1	P	<p>2.5V or 3.3V power for analog IO</p> <p>LAN7430 only This pin provides power for Gigabit PHY transmitter, bandgap reference, and crystal oscillator amplifier.</p> <p>LAN7431 only This pin provides power for bandgap reference and crystal oscillator amplifier.</p>
Ethernet PHY +2.5V / 3.3V Analog Power Supply	AVDDH_2	P	<p>2.5V or 3.3V power for analog IO</p> <p>(LAN7430 only) This pin provides power for Gigabit PHY transmitter.</p>

# LAN7430/LAN7431

**TABLE 3-3: PIN DESCRIPTIONS (CONTINUED)**

Name	Symbol	Buffer Type	Description
Ethernet PHY +1.2V Analog Power Supply	AVDDL_1	P	1.2V power for analog core
Ethernet PHY +1.2V Analog Power Supply	AVDDL_2	P	1.2V power for analog core  (LAN7430 only) This is an additional power pin for the 1.2V analog core.
PCIe PHY High Voltage Supply	VPH	P	2.5V PCIe PHY power
PCIe PHY Transmit Supply	VPTX	P	1.2V PCIe PHY TX power
PCIe PHY Analog and Digital Supply	VP	P	1.2V PCIe PHY power
Variable I/O Power Supply Input Group A	VDDVARIO	P	1.8V - 3.3V variable supply for I/Os
Variable I/O Power Supply Input Group B	VDDVARIO_B	P	1.8V - 3.3V variable supply for RGMII and MII related I/Os  (LAN7431 only) This is the power pin for the RGMII and MII related I/Os (TXD3, TXD2, TXD1, TXD0, TX_ER/MII_EN, TX_CTL/TX_EN, TXC/TX_CLK, RXC/RX_CLK, RX_CTL/RX_DV, RXD0, RXD1, RXD2, RXD3, CLK125/RX_ER, REF-CLK_25/GPIO11, COL/GPIO10, CRS).
OTP Power	VDD_OTP	P	3.3V to OTP charge pump  3.3V supply voltage for PCIe I/Os (CLKREQ#, WAKE#, PERST#)
Switcher Input Voltage	VDD_SW_IN	P	1.8V - 3.3V input voltage for switching regulator
Switcher Feedback	VDD12_SW_FB	P	Feedback pin for the integrated switching regulator  <b>Note:</b> Tie this pin to <a href="#">VDD_SW_IN</a> to disable the switching regulator.
Switcher +1.2V Unfiltered Output Voltage	VDD12_SW_OUT	P	1.2V output voltage from switching regulator
LDO Input Voltage	VDD_REG_IN	P	3.3V input supply to the integrated LDO  <b>Note:</b> If this supply is set to 2.5V than it shall be externally connected to <a href="#">VDD25_REG_OUT</a> . See <a href="#">Section 4.0, "Power Connectivity"</a> for details.
LDO Output	VDD25_REG_OUT	P	2.5V output supply from the integrated LDO  This is used to supply power to the PCIE PHY and optionally to the Gigabit Ethernet PHY AFE.
Digital Core +1.2V Power Supply Input	VDD12CORE	P	1.2V digital core power.



**TABLE 3-3: PIN DESCRIPTIONS (CONTINUED)**

Name	Symbol	Buffer Type	Description
PCIe Ground	GD_1 GD_2 GD_3	P	PCIe ground.
Ground	VSS	P	Common ground.  This exposed pad must be connected to the ground plane with a via array.

### 3.4 Configuration Straps

Configuration straps are latched on [Power-On Reset \(POR\)](#) and [External Chip Reset \(RESET\\_N\)](#) and are identified by an underlined symbol name. Configuration straps are multi-function pins that are driven as outputs during normal operation. During a [Power-On Reset \(POR\)](#) or an [External Chip Reset \(RESET\\_N\)](#), these outputs are not driven. The high or low state of the signal is latched following deassertion of the reset and is used to determine the default configuration of a particular feature. The following configuration strap signals are available:

- [ADV\\_PM\\_DISABLE](#)
- [MII\\_EN](#) (LAN7431 only)

Configuration straps include internal resistors in order to prevent the signal from floating when unconnected. If a particular configuration strap is connected to a load, an external pull-up or pull-down should be used to augment the internal resistor to ensure that it reaches the required voltage level prior to latching. The internal resistor can also be overridden by the addition of an external resistor. When externally pulling configuration straps high, the strap should be tied to [VDDVARIO](#) or [VDDVARIO\\_B](#) as indicated in the pin descriptions.

The system designer must ensure that configuration straps meet the timing requirements specified in [Section 7.6.3, "Power-On Configuration Strap Timing"](#) and [Section 7.6.4, "Reset Pin Configuration Strap Timing"](#). If configuration straps are not at the correct voltage level prior to being latched, the device may capture incorrect strap values.

**Note:** Configuration straps must never be driven as inputs. If required, configuration straps can be augmented, or overridden with external resistors.

# LAN7430/LAN7431

## 4.0 POWER CONNECTIVITY

This section details the power connectivity of the LAN7430 and LAN7431 in various configurations. Power sequence timing is detailed in [Section 7.6.2, "Power Sequence Timing"](#).

### 4.1 LAN7430 Power Connectivity

The following diagrams illustrate the power connectivity for LAN7430 with on-chip regulators enabled and disabled.

**FIGURE 4-1: LAN7430 POWER CONNECTIVITY ON-CHIP REGULATORS ENABLED**

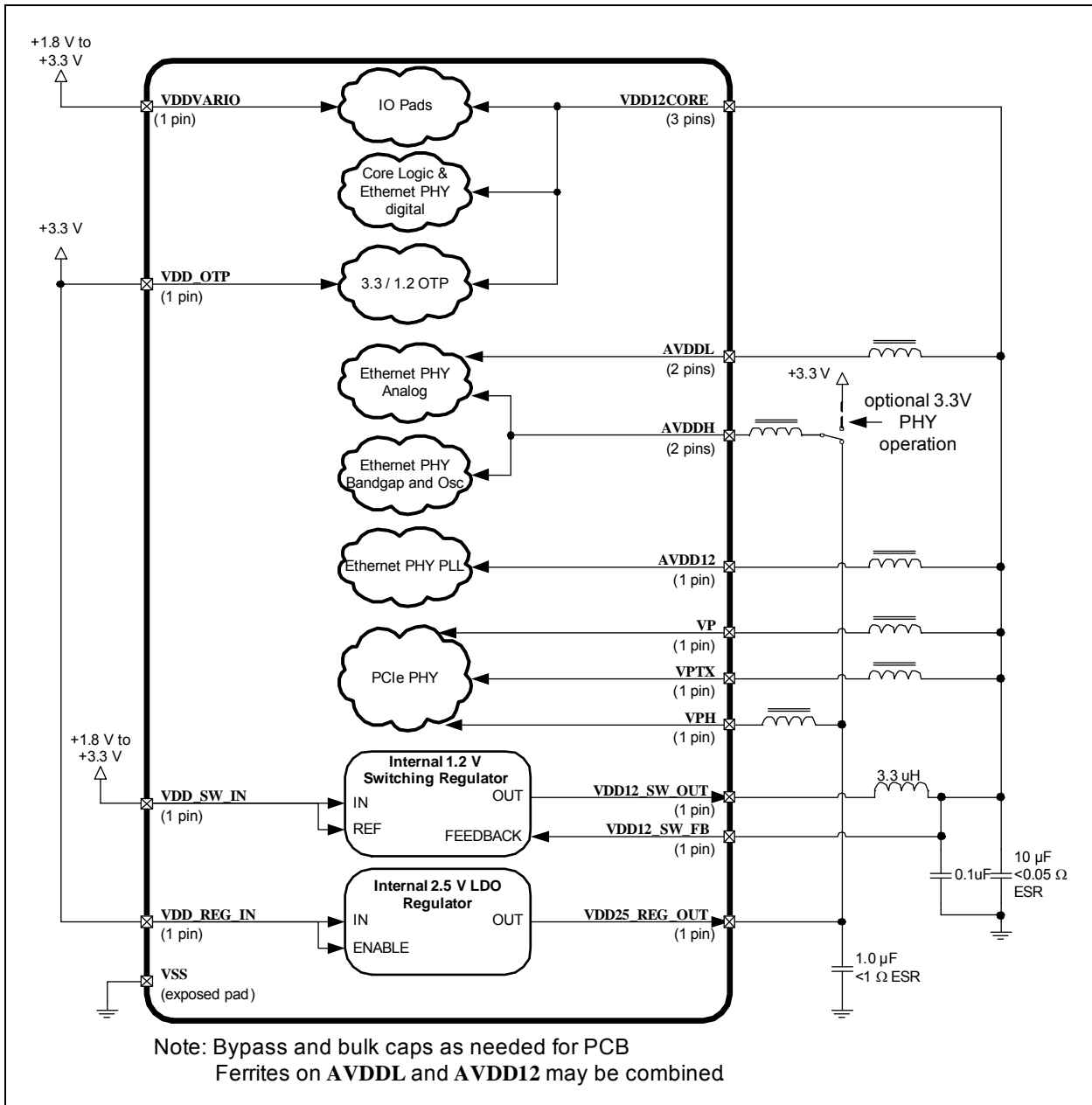

**FIGURE 4-2: LAN7430 POWER CONNECTIVITY ON-CHIP REGULATORS DISABLED**

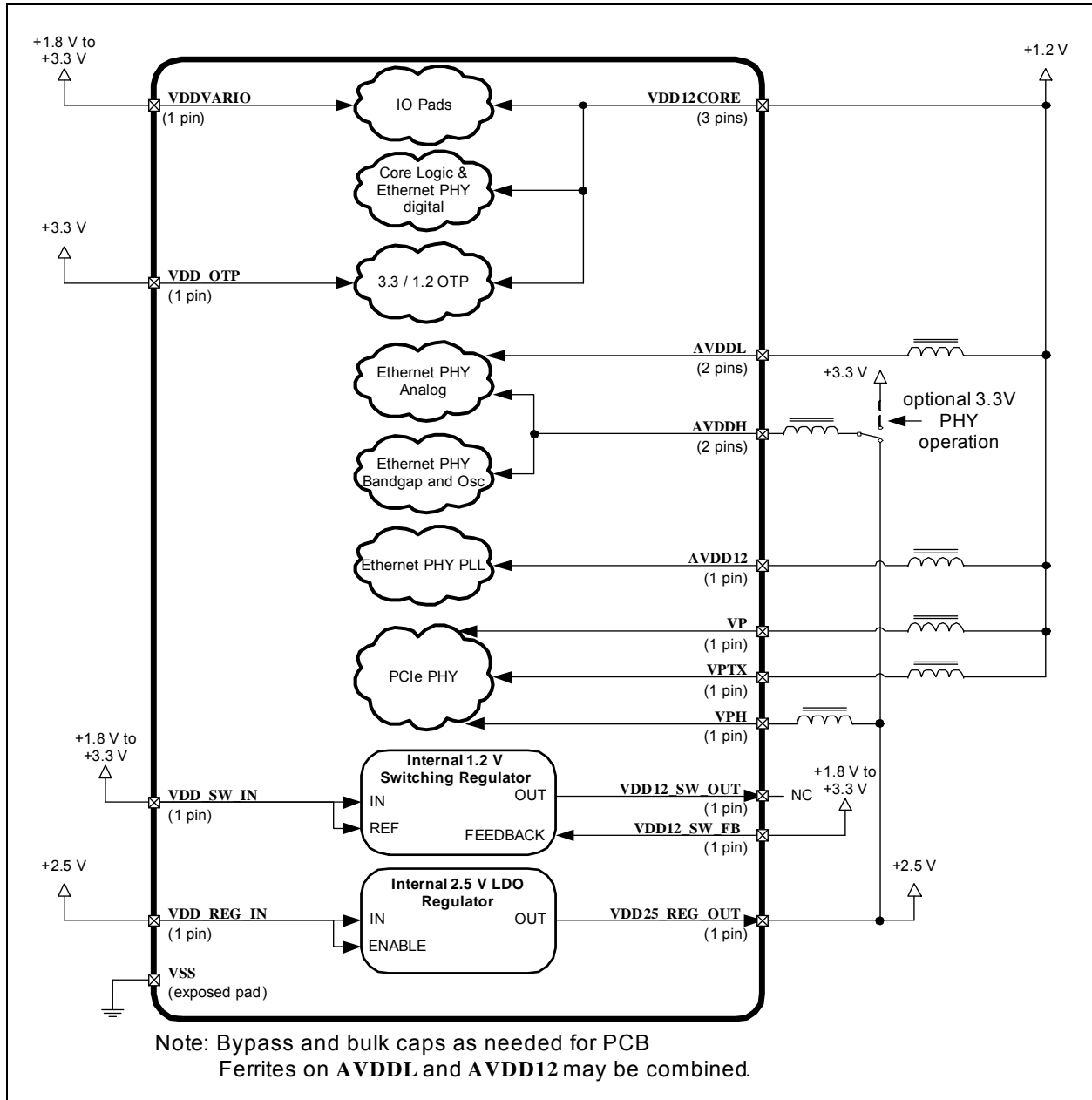

# LAN7430/LAN7431

## 4.2 LAN7431 Power Connectivity

The following diagram illustrates the power connectivity for LAN7431 with on-chip regulators enabled and disabled.

**FIGURE 4-3: LAN7431 POWER CONNECTIVITY ON-CHIP REGULATORS ENABLED**

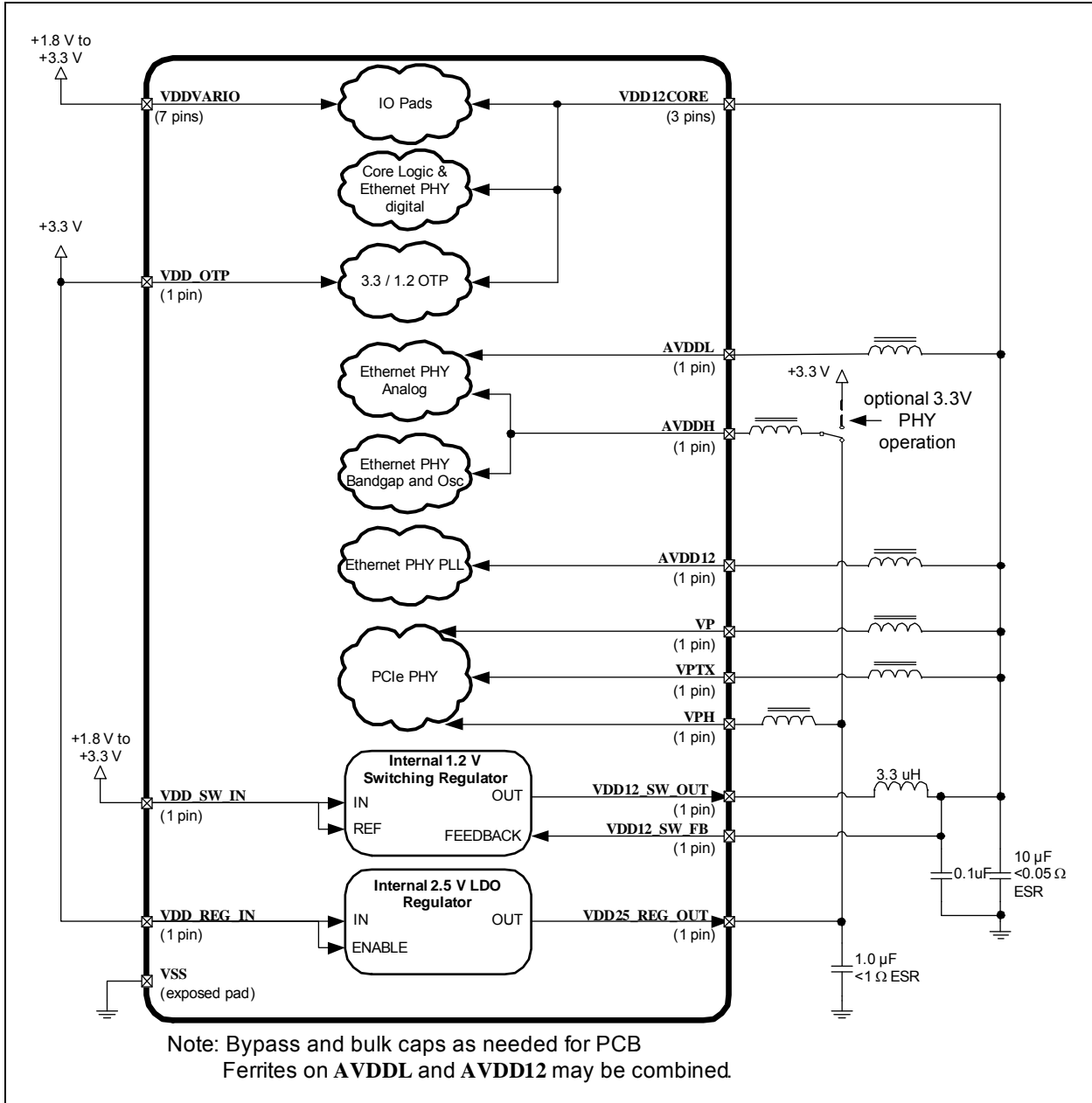

**FIGURE 4-4: LAN7431 POWER CONNECTIVITY ON-CHIP REGULATORS DISABLED**

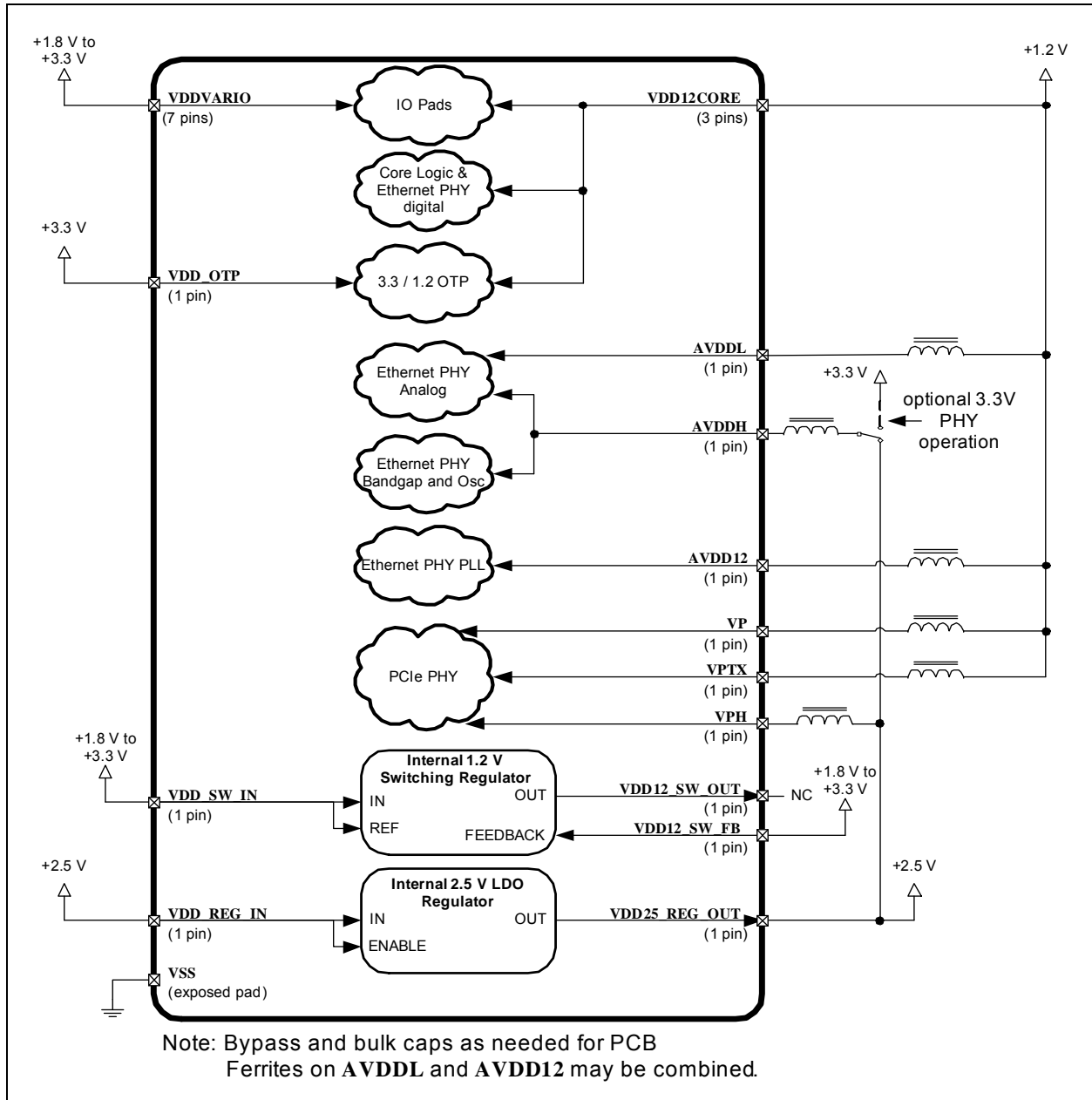

# LAN7430/LAN7431

---

## 5.0 DEVICE CONFIGURATION

### 5.1 Device Drivers

Microchip provides LAN7430/LAN7431 software device drivers for the following operating systems:

- Windows 10
- Windows 8.x
- Windows 7
- Windows OneCore
- Linux
- Android

To download the latest LAN7430/LAN7431 drivers, refer to the Microchip product pages at [www.microchip.com/LAN7430](http://www.microchip.com/LAN7430) and [www.microchip.com/LAN7431](http://www.microchip.com/LAN7431).

### 5.2 Programming Tools

The LAN7430/LAN7431 supports a large number of configurable features. Microchip provides a comprehensive software programming tool, MPLAB Connect Configurator (formerly ProTouch2), for EEPROM and OTP configuration of various device functions and registers. All configuration is to be performed via the MPLAB Connect Configurator programming tool. For additional information on this tool, refer to the MPLAB Connect Configurator programming tool product page at <http://www.microchip.com/design-centers/usb/mplab-connect-configurator>.

**Note:** Device configuration straps are detailed in [Section 3.4, "Configuration Straps," on page 25](#). Refer to [Section 6.10, "EEPROM Controller \(EEP\)"](#) and [Section 6.11, "One Time Programmable Memory \(OTP\)"](#) for detailed information on each device interface.

## 6.0 FUNCTIONAL DESCRIPTIONS

This section provides additional details of the major features supported by the LAN7430/LAN7431.

- [PCI Express PHY \(PCIe PHY\)](#)
- [PCI Express Endpoint Controller \(PCIe EP\)](#)
- [Gigabit Ethernet Media Access Controller \(MAC\)](#)
- [RGMII \(LAN7431 Only\)](#)
- [Gigabit Ethernet PHY \(GPHY\) \(LAN7430 Only\)](#)
- [IEEE 1588v2 \(PTP\)](#)
- [Receive Filtering Engine \(RFE\)](#)
- [DMA Controller \(DMAC\)](#)
- [FIFO Controller \(FCT\)](#)
- [EEPROM Controller \(EEP\)](#)
- [One Time Programmable Memory \(OTP\)](#)
- [Resets](#)
- [Power Management](#)
- [Integrated Voltage Regulators](#)
- [JTAG](#)
- [Miscellaneous](#)

### 6.1 PCI Express PHY (PCIe PHY)

The PCIe PHY forms the physical interface between the device's PCIe endpoint control and the PCIe host bus. It supports chip-to-chip and card-to-card connectivity across a combination of printed circuit board, connectors, backplane wiring or cables.

The PCIe PHY is compliant with all of the required features of the PCIe Base Specification, Revision 3.1 (for legacy 2.5 GT/s support).

The low power L1, L1.1 and L1.2 sub-states are supported per the PCIe Base 3.1 Specification.

#### 6.1.1 FEATURES

- 2.5 GT/s data transmission rate
- PIPE3 compliant Transceiver Interface
- Integrated PHY includes transmitter, receiver, PLL, and digital core
- Programmable RX equalization
- Designed for excellent performance margin and receiver sensitivity
- Low jitter PLL technology with excellent supply isolation

The PHY supports a 2.5 GT/s data rate. Since bytes are encoded using the 8b/10b mechanism, this equates to a 2.0 Gbps data rate.

This device supports a PCIe link width of one lane.

#### 6.1.2 REFERENCE CLOCK

The PHY utilizes an external 100MHz differential reference clock, supplied by the host system. PCIe architecture defines three clock distribution methods: common clock, data clock, and separate clock. The LAN7430/LAN7431 devices support the common clock method where both end devices, such as a host and the device, are using the same clock source. The details of the common clock method are provided in the PCIe specification.

#### 6.1.3 TERMINATION RESISTANCE

The PHY includes on chip terminations for the TX and RX I/Os.

Termination on the PCIe reference clock pins is provided by the host.

##### 6.1.3.1 Termination Resistance Tuning

The PHY uses an external resistor to calibrate the termination impedances of the high speed inputs and outputs of the PHY. A 200 Ohm +/-1% resistor should be connected from the **RESREF** pin to ground.

# LAN7430/LAN7431

---

## 6.1.4 TERMINATION CAPACITORS

The TX pins require series capacitors in the range of 100nF to 200nF.

## 6.1.5 BEACONING

The PHY supports the PCIe beaconing wake-up mechanism.

## 6.2 PCI Express Endpoint Controller (PCIe EP)

The device integrates a PCIe 3.1 Endpoint controller that includes the following common PCIe features:

- Split transaction, packet-based protocol
- Common flat address space for load/store access
  - 32 and 64-bit memory address spaces
  - I/O address space
  - Configuration address space
- Transaction layer mechanism
- Credit-based flow control
- Various packet sizes and formats
- Reset and initialization
- Data integrity support
- Link layer retry for recovery following error detection
- 8b/10b encoding with running disparity
- In-band messaging
- Power management:
  - Wake capability from D3cold state
  - Compliant with ACPI, PCI-PM software model
  - Active state power management

Additional functional features supported include:

- All non-optional features of the PCI Express Base 3.1 Specification
- The following optional features of the specification:
  - Latency Tolerance Reporting (LTR)
  - Completion Timeout Ranges
  - Function Level Reset (FLR)
  - L1 Substates (L1SS, L1.1SS, L1.2SS)
  - Optimized Buffer Fill and Flush (OBFF)
  - Readiness Notifications (RN)
  - PCI Express Active State Power Management (ASPM)
  - PCI Express Advanced Error Reporting (AER) with Multiple Header Logging
  - Device Serial Number
  - ECRC generation and checking
- x1 Gen1 Lane @ 2.5 GT/s
- Advanced Power and Clock Management
- Configurable Max\_Payload\_Size (128 bytes to 512 bytes)
- MSI and MSI-X with Per-Vector Masking (PVM)
- INTx Legacy interrupt emulation
- Type 0 Configuration space



## 6.3 Gigabit Ethernet Media Access Controller (MAC)

The Ethernet Media Access controller (MAC) incorporates the essential protocol requirements for operating an Ethernet/IEEE 802.3-compliant node and interfaces to the integrated Gigabit Ethernet PHY (LAN7430 only), or MII/RGMII interface (LAN7431 only). The MAC can operate in full-duplex 1000 Mbps or half/full-duplex 10/100 Mbps mode.

When operating in half-duplex mode, the MAC complies fully with Section 4 of ISO/IEC 8802-3 (ANSI/IEEE standard) and ANSI/IEEE 802.3 standards. When operating in full-duplex mode, the MAC complies with IEEE 802.3x full-duplex operation standard.

The MAC provides programmable enhanced features designed to minimize Host supervision, bus utilization, and pre- or post-message processing. These features include the ability to disable retries after a collision, dynamic FCS (Frame Check Sequence) generation on a frame-by-frame basis, automatic pad field insertion and deletion to enforce minimum frame size attributes, and automatic retransmission and detection of collision frames.

The primary attributes of the MAC are:

- Interfaces to the internal Gigabit Ethernet PHY (LAN7430 only), or MII/RGMII interface (LAN7431 only)
- Transmit and receive message data encapsulation
- Framing (frame boundary delimitation, frame synchronization)
- Error detection (physical medium transmission errors)
  - Including Length Field testing
- FCS checking/stripping/generation
- Preamble stripping/generation
- Media access management
- Medium allocation (collision detection, except in full-duplex operation)
- Contention resolution (collision handling, except in full-duplex operation)
- Flow control during full-duplex mode
- Decoding of control frames (PAUSE command) and disabling the transmitter
- Generation of control frames (PAUSE command)
- Maintains minimum inter packet gap (IPG)
- Magic packet/Wake-On-LAN (WOL) detection
- Remote wakeup frame detection
- Neighbor Solicitation offload
- ARP offload
- Implements Simple Network Management Protocol (SNMP) and Remote Monitoring (RMON) management counter sets
- Jumbo frames supported up to 9220 bytes

## 6.4 RGMII (LAN7431 Only)

The integrated Reduced Gigabit Media Independent Interface (RGMII) is a Dual Data Rate (DDR) interface that consists of a transmit path and a receive path. Both paths have an independent clock (**TXC** & **RXC**), 4 data signals, and a control signal. Because of this design, RGMII does not have distinct PHY/MAC roles and special hardware considerations are not required for a MAC-to-MAC connection. When source-synchronous clocking is used for MAC-to-MAC connections, the clock signal that is output (by either path) is synchronous with the related data signals. This requires the PCB to be designed to add a 1.5-2 ns delay to the clock signal to meet the setup and hold times on the sink. The RGMII interface supports both Version 1.3 and Version 2.0 of the RGMII specification. Version 1.3 of the RGMII Specification requires a 1.5 to 2ns clock delay via a PCB trace delay. Version 2.0 of the RGMII Specification introduces the option of an on-chip Internal Delay (ID). These distinct RGMII modes of operation are referred to as “Non-ID Mode” and “ID Mode”, respectively.

The LAN7431 requires an external 125MHz clock reference on the **CLK125** pin. The LAN7431 MAC may receive a 125 MHz reference clock from the partner PHY or MAC, which is used for generating the RGMII **TXC** signal. If this option is not available, the Generate CLK125 MHz Enable (CLK125\_EN) field of the Hardware Configuration Register (HW\_CFG) shall be set. When set, the device will generate the 125 MHz clock internally. For the processor MAC, several options are possible:

- The 125MHz clock reference is available internally.

# LAN7430/LAN7431

- The 125MHz clock is provided from an external clock source.
- The LAN7431 can output a 25MHz reference Clock that can be converted for generating the RGMII TXC Signal.

Table 6-1 describes the RGMII signals. Refer to the RGMII Version 2.0 Specification for more detailed information.

**TABLE 6-1: RGMII SIGNAL DEFINITION**

RGMII Signal Name	Pin Type (with respect to LAN7431)	Pin Type (with respect to MAC)	Description
TXC	Output	Input	Transmit Reference Clock (125MHz for 1000Mbps, 25MHz for 100 Mbps, 2.5MHz for 10 Mbps)
TX_CTL	Output	Input	Transmit Control
TXD[3:0]	Output	Input	Transmit Data [3:0]
RXC	Input	Output	Receive Reference Clock (125MHz for 1000Mbps, 25MHz for 100 Mbps, 2.5MHz for 10 Mbps)
RX_CTL	Input	Output	Receive Control
RXD[3:0]	Input	Output	Receive Data [3:0]

The LAN7431 RGMII pin connections to a MAC are detailed in Figure 6-1.

**FIGURE 6-1: RGMII SIGNAL DIAGRAM**

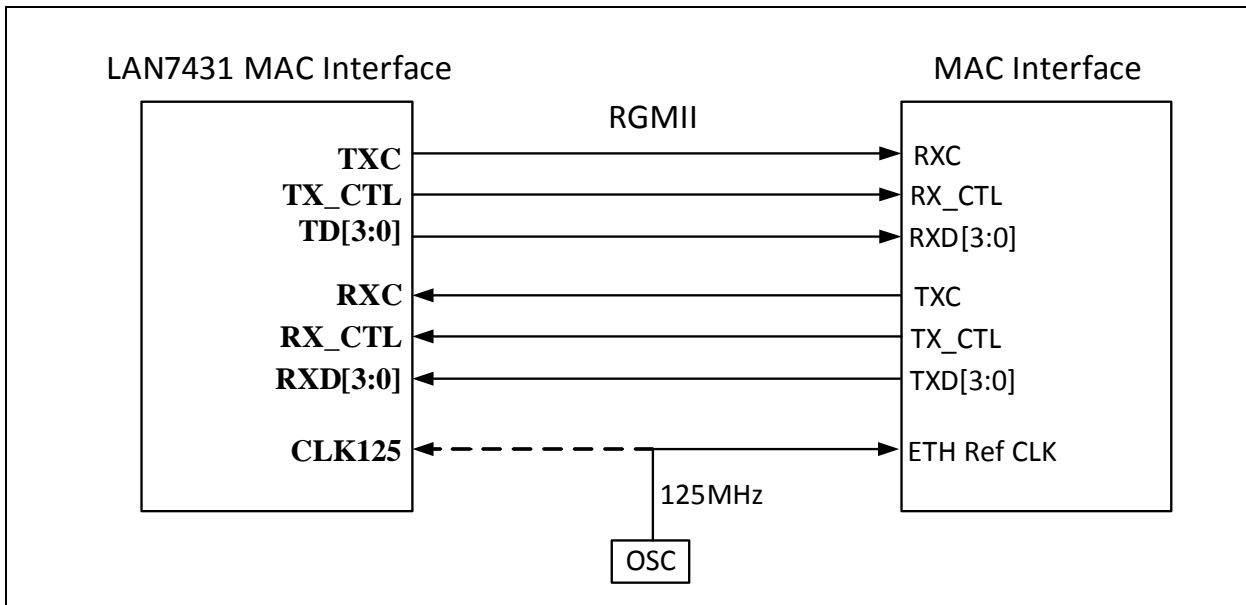

## 6.5 Gigabit Ethernet PHY (GPHY) (LAN7430 Only)

The device (LAN7430 only) incorporates a low-power Gigabit Ethernet PHY (GPHY) transceiver that is fully compliant with the IEEE 802.3, 802.3u, 802.3ab, and 802.3az (Energy Efficient Ethernet) standards. It provides a low electromagnetic interference (EMI) line driver, and integrated line side termination resistors that conserve both power and printed circuit board (PCB) space.

The mixed signal and digital signal processing (DSP) architecture of the Ethernet PHY assures robust performance even under less-than-favorable environmental conditions. It supports both half-duplex and full-duplex 10BASE-T and 100BASE-TX, and full-duplex 1000BASE-T communication speeds over Category 5 (Cat5) unshielded twisted pair (UTP) cable at distances greater than 100m, displaying excellent tolerance to NEXT, FEXT, echo, and other types of ambient environment and system electronic noise. The Ethernet PHY implements Auto-Negotiation to automatically determine the best possible speed and duplex mode of operation. Auto-MDIX support allows the use of direct connect or cross-over LAN cables.

The Ethernet PHY is configurable via the Ethernet PHY Control and Status. These registers are accessed indirectly through the Ethernet MAC via the MII Access Register (MII\_ACCESS) and MII Data Register (MII\_DATA).

The Gigabit Ethernet PHY has the following main features:

- Auto-Negotiation to Automatically Select the Highest Link-Up Speed (10/100/1000 Mbps) and Duplex (Half/Full)
- Voltage-mode Line driver with On-Chip Termination Resistors for the Differential Pairs
- Jumbo Frame Support Up to 16 KB (MAC supports 9220 bytes)
- Energy-Detect Power-Down Mode for Reduced Power Consumption When the Cable is not attached
- Energy Efficient Ethernet (EEE) Support with Low-Power Idle (LPI) Mode and Clock Stoppage for 100BASE-TX/1000BASE-T and Transmit Amplitude Reduction with 10BASE-T<sub>e</sub> Option
- Programmable LED Outputs for Link, Activity, and Speed
- Baseline Wander Correction
- TDR-based Cable Diagnostic to Identify Faulty Copper Cabling
- Loopback Modes for Diagnostics
- Automatic MDI/MDI-X Crossover to Detect and Correct Pair Swap at All Speeds of Operation
- Automatic Detection and Correction of Pair Swaps, Pair Skew, and Pair Polarity
- Power-Down and Power-Saving Modes
- Signal Quality Indication

## 6.6 IEEE 1588v2 (PTP)

The device provides hardware support for the IEEE 1588-2008 (v2) Precision Time Protocol (PTP), allowing clock synchronization with remote Ethernet devices, packet time stamping, and time driven event generation.

The device may function as a master or a slave clock per the IEEE 1588-2008 specification. End-to-end and peer-to-peer link delay mechanisms are supported as are one-step and two-step operations.

A 32-bit seconds and 30-bit nanoseconds tunable clock is provided that is used as the time source for all PTP timestamp related functions. A 1588 Clock Events sub-module provides 1588 Clock comparison based interrupt generation and timestamp related GPIO event generation. GPIO pins can be used to trigger a timestamp capture when configured as an input, or output a signal based on a 1588 Clock timer compare event.

All features of the IEEE 1588 unit can be monitored and configured via their respective configuration and status registers.

### 6.6.1 IEEE 1588-2008

IEEE 1588-2008 specifies a Precision Time Protocol (PTP) used by master and slave clock devices to pass time information in order to achieve clock synchronization. Ten network message types are defined:

- Sync
- Follow\_Up
- Delay\_Req
- Delay\_Resp
- PDelay\_Req
- PDelay\_Resp

# LAN7430/LAN7431

---

- PDelay\_Resp\_Follow\_Up
- Announce
- Signaling
- Management

The first seven message types are used for clock synchronization. Using these messages, the protocol software may calculate the offset and network delay between timestamps, adjusting the slave clock frequency as needed. Refer to the IEEE 1588-2008 protocol for message definitions and proper usage.

A PTP domain is segmented into PTP sub-domains, which are then segmented into PTP communication paths. Within each PTP communication path there is a maximum of one master clock, which is the source of time for each slave clock. The determination of which clock is the master and which clock(s) is(are) the slave(s) is not fixed, but determined by the IEEE 1588-2008 protocol. Similarly, each PTP sub-domain may have only one master clock, referred to as the Grand Master Clock.

PTP communication paths are conceptually equivalent to Ethernet collision domains and may contain devices which extend the network. However, unlike Ethernet collision domains, the PTP communication path does not stop at a network switch, bridge, or router. This leads to a loss of precision when the network switch/bridge/router introduces a variable delay. Boundary clocks are defined which conceptually bypass the switch/bridge/router (either physically or via device integration). Essentially, a boundary clock acts as a slave to an upstream master, and as a master to a downstream slave. A boundary clock may contain multiple ports, but a maximum of one slave port is permitted.

Although boundary clocks solve the issue of the variable delay influencing the synchronization accuracy, they add clock jitter as each boundary clock tracks the clock of its upstream master. Another approach that is supported is the concept of transparent clocks. These devices measure the delay they have added when forwarding a message (the residence time) and report this additional delay either in the forwarded message (one-step) or in a subsequent message (two-step).

The PTP relies on the knowledge of the path delays between the master and the slave. With this information, and the knowledge of when the master has sent the packet, a slave can calculate its clock offset from the master and make appropriate adjustments. There are two methods of obtaining the network path delay. Using the end-to-end method, packets are exchanged between the slave and the master. Any intermediate variable bridge or switch delays are compensated by the transparent clock method described above. Using the round trip time and accounting for the residence time reported, the slave can calculate the mean delay from the master. Each slave sends and receives its own messages and calculates its own delay. While the end-to-end method is the simplest, it does add burden on the master since the master must process packets from each slave in the system. This is amplified when boundary clocks are replaced by transparent clocks. Also, the end-to-end delays must be recalculated if there is a change in the network topology. Using the peer-to-peer method, packets are exchanged only between adjacent master, slaves and transparent clocks. Each peer pair calculates the receive path delay. As time synchronization packets are forwarded between the master and the slave, the transparent clock adds the pre-measured receive path delay into the residence time. The final receiver adds its receive path delay. Using the peer-to-peer method, the full path delay is accounted for without the master having to service each slave. The peer-to-peer method better supports network topology changes since each path delay is kept up-to-date regardless of the port status.

The PTP implementation consists of the following major function blocks:

- PTP Timestamp  
This block provides time stamping and packet modification functions.
- 1588 Clock  
This block provides a tunable clock that is used as the time source for all PTP timestamp related functions.
- 1588 Clock Events  
This block provides clock comparison-based interrupt generation and timestamp related GPIO event generation.
- 1588 GPIOs  
This block provides for time stamping GPIO input events and for outputting clock comparison-based interrupt status.
- 1588 Interrupts  
This block provides interrupt generation, masking and status.
- 1588 Registers  
This block provides contains all configuration, control and status registers.

## 6.7 Receive Filtering Engine (RFE)

The RFE receives Ethernet frames from the Ethernet MAC, processes them, and passes them to the RX FIFO Controller (FCT). The RFE is responsible for filtering the received Ethernet frames, verifying the TCP/UDP/ICMP/IGMP and IP checksum, and removing the VLAN tag.

When receiving a frame from the MAC, the RFE will obtain the frame data and status information. Upon completion of frame processing, the RFE encapsulates its status with the status information obtained from the MAC, and passes this information (along with the frame data) on to the FCT in the form of RX Command A, RX Command B, RX Command C and RX Command D. The RFE also passes the receive timestamp from the 1588 module to the FCT.

The RFE, if enabled, can remove a VLAN tag from the frame. VLAN tag stripping is controlled by the Enable VLAN Tag Stripping bit of the Receive Filtering Engine Control Register (RFE\_CTL). If this bit is set, the tag will be stripped. If clear, the RFE will not modify the frame in any way.

If multiple VLAN tags are present in a frame, the RFE only removes the first tag (adjacent to the MAC source address).

The RFE provides the Layer 3 Checksum (if enabled) and VLAN ID via RX Command B, while RX Command A, RX Command C and RX Command D contain the frame's status.

When the RFE determines a frame has a checksum error, it sets the appropriate error bits in RX Command A to identify the error condition.

The FCT does not rewind frames that failed checksum validation from the FCT RX FIFO.

The RFE also determines the correct RX FCT channel in which to place the frame, based on various priorities methods or MAC source or destination address or based on the Microsoft Receive Side Scaling specification. In order to minimize delays through the RFE, data is processed on the fly and stored into all FIFOs in parallel. Once a determination is made as to the correct destination FIFOs, the other FIFOs are instructed to drop the packet.

## 6.8 DMA Controller (DMAC)

The DMA Controller (DMAC) consists of independent receive (RX) and transmit (TX) DMACs, a series of arbiters, and a control and status register space (CSRs). The TX DMAC transfers Ethernet frames from host memory to the FIFO Controller (FCT), while the RX DMAC transfers Ethernet frames from the FCT to host memory. Both the RX and TX DMACs have independent channels allocated to them (4 RX, 1 TX), through which the data transfer occurs.

Both the RX and TX DMACs utilize descriptors to efficiently move data from source to destination with minimal CPU intervention. Descriptors are data structures in host memory that inform the DMAC of the location of data buffers in host memory. In the case of the RX DMAC, it also provides a mechanism for communicating status to the CPU on completion of DMA transactions. The host is responsible for setting up the descriptor rings and allocating RX descriptor buffers. TX descriptor buffers are allocated and placed into the ring as needed. Each channel has its own descriptor ring and data buffers. Descriptors are cached on chip to help absorb host bus latency.

The DMAC can be programmed to assert an interrupt for situations such as frame transmit or receive transfer completed, and other conditions.

## 6.9 FIFO Controller (FCT)

The FIFO controller uses internal RAMs to buffer RX and TX traffic. Host transmit data, via the DMAC, is directly stored into the FCT TX FIFO(s). The FCT is responsible for extracting Ethernet frames from the host data and passing the frames to the MAC.

Received Ethernet Frames are stored into the FCT RX FIFOs and become the basis for DMAC to host memory transfers.

### 6.9.1 RX PATH (ETHERNET TO HOST)

The Receive direction buffer space consists of four parallel, independent channels. Each of the four 32 KB RX FIFOs buffer Ethernet frames received from the RFE. The DMAC transfers these frames from the FCT to the host system memory. Host software will ultimately reassemble the Ethernet frames from the DMAC transfers.

# LAN7430/LAN7431

---

## 6.9.2 TX PATH (HOST TO ETHERNET)

The 20 KB TX FIFO buffers data transferred by the DMAC from system memory. The FCT is responsible for extracting the Ethernet frames embedded in the data and passing them to the MAC.

The FCT receives valid data from the DMAC and writes it into the TX FIFO. The write side of the FCT does not perform any processing on the data. No provisions for rewind on the write side are required, as the DMAC manages its own buffer RAM and performs rewinds in the event that a DMA transfer is errored. When the FCT writes the Ethernet frame into the FCT TX FIFO RAM, it prepends a DWORD in front of the TX Command Words, used for internal processing, that contains the length of the Ethernet frame. The read side of the FCT TX FIFO is responsible for extracting the Ethernet frames.

## 6.10 EEPROM Controller (EEP)

The device may use an external EEPROM to store the default values for the PCIe controller and the MAC address. The EEPROM controller supports most "93C56 or 93C66" type 256/512 byte EEPROMs. A total of nine address bits are used.

After a system-level reset occurs, the device loads the default values from EEPROM. The device is connected to the PCIe bus but responds with CRS until this process is completed. The EEPROM controller also allows the Host to read, write and erase the contents of the Serial EEPROM.

**Note:** A Microwire-style 2K/4K EEPROM that is organized for 256/512 x 8-bit operation must be used.

**Note:** All EEPROM configuration is to be performed via the MPLAB Connect Configurator programming tool. Refer to [Section 5.2, "Programming Tools"](#) for additional information.

### 6.10.1 EEPROM AND OTP RELATIONSHIP

A detected external EEPROM always takes precedence over the OTP. When determining the source to configure the device the following order is used.

1. EEPROM Configuration
2. OTP Configuration
3. CSR defaults

The Configuration and Status Registers defaults are used if neither the EEPROM nor OTP is determined to be configured.

### 6.10.2 EEPROM / OTP AUTO-LOAD

Certain system level resets ([PCIe Fundamental Reset](#), [Hot Resets](#), [Function-Level Reset \(FLR\)](#), [Power Management Soft Reset](#), [Power-On Reset \(POR\)](#), [External Chip Reset \(RESET\\_N\)](#) and [Soft Reset](#)) may cause the EEPROM or OTP contents to be auto-loaded into the device.

Depending on the reset event, either the PCIe Configuration registers, the system Configuration Status Registers, or both are programmed. See [Section 6.12, "Resets"](#) for additional information.

**APPLICATION NOTE:** Certain reset events cause a restoration from previously read EEPROM / OTP values rather than rereading the EEPROM or OTP.

#### 6.10.2.1 Magic Byte

##### 6.10.2.1.1 EEPROM

After a reset, the EEPROM loader attempts to read the first byte of data from the EEPROM. If the value A5h or AAh is read from the first address, then the EEPROM loader will assume that a programmed external Serial EEPROM is present. A value of AAh in the first address indicates that only the MAC address is to be read and used.

##### 6.10.2.1.2 OTP

As with the EEPROM, a signature is required to define whether or not the OTP has been programmed. If the value F3h or F7h is found at byte 0, the OTP shall be determined to be programmed.

A signature of F3h indicates that the device is configured using values (MAC Address and subsequent as per EEPROM Contents) from byte offset 1 in the OTP. A value of F7h indicates that the device is configured loading values (MAC Address and subsequent as per EEPROM Contents) from byte offset 513 in the OTP.

**APPLICATION NOTE:** The dual signatures enable a mechanism for the OTP to be programmed twice. This may prove useful for initial bring up of the device where inadvertently mis-programming the device could render it non-functional. This scheme requires that when a signature of F3h is used that only the first 512 bytes (0 through 511) of the OTP are programmed. In the event that the OTP was mis-configured the device can be “saved” by changing the signature on byte 0 from F3h to F7h and writing the new content starting at byte 513.

As with the EEPROM, if a valid signature is not present at byte 0, the OTP shall be deemed to not be programmed and the hardware shall not use it for configuring the device. Unlike the EEPROM, there is no signature value (e.g. AAh) that indicates that only the MAC address is to be loaded.

## 6.10.2.2 Blank / No EEPROM

If A5h or AAh (EEPROM) or F3h or F7h (OTP) is not read from the first address, the EEPROM loader will end initialization. The device default values will be assumed unless a configured OTP is present.

Where there is no EEPROM or OTP, it is the responsibility of the Host LAN driver software to set the IEEE 802.3 address by writing to the MAC Receive Address High Register (RX\_ADDRH) and MAC Receive Address Low Register (RX\_ADDR\_L).

## 6.11 One Time Programmable Memory (OTP)

The device integrates a 1K One Time Programmable (OTP) memory to store various configuration data and serve as an EEPROM replacement to reduce bill of material costs. The OTP supports single bit writes and 8-bit reads. An included OTP interrupt is available to indicate when the OTP is ready. The OTP provides a configurable standby mode that reduces its power when operations have been completed.

OTP may potentially co-exist with an external EEPROM. Refer to [Section 6.10.1, "EEPROM and OTP Relationship"](#) for additional details.

Certain system level resets may cause the OTP contents to be auto-loaded into the device. Refer to [Section 6.10.2, "EEPROM / OTP Auto-Load"](#) for additional details.

**Note:** All OTP configuration is to be performed via the MPLAB Connect Configurator programming tool. Refer to [Section 5.2, "Programming Tools"](#) for additional information.

## 6.12 Resets

The device provides the following chip-level reset sources:

- [Power-On Reset \(POR\)](#)
- [External Chip Reset \(RESET\\_N\)](#)
- [PCIe Fundamental Reset](#)
- [Hot Resets](#)
- [Function-Level Reset \(FLR\)](#)
- [Soft Reset](#)
- [Soft-Lite Reset](#)
- [Power Management Soft Reset](#)

Additionally, the device provides non-chip-level resets:

- [Ethernet PHY Software Reset](#)
- [External PHY Reset](#)

# LAN7430/LAN7431

---

## 6.12.1 POWER-ON RESET (POR)

A Power-On Reset (POR) occurs whenever power is initially applied to the device, or if power is removed and reapplied to the device. A timer within the device will assert the internal reset for approximately 20 ms. EEPROM/OTP contents are loaded by this reset. Configuration straps are also loaded by this reset.

The POR is a combination of four separate POR circuits that measure the voltage on the following domains:

- 3.3V to 1.8V (set for 1.8V typical) - [VDDVARIO](#), [VDDVARIO\\_B](#)
- 1.2V - [AVDD12](#), [AVDDL\\_1](#), [AVDDL\\_2](#), [VPTX](#), [VP](#), [VDD12CORE](#) (monitored on [AVDD12](#) and [VDD12CORE](#))
- 2.5V - [VPH](#), [AVDDH\\_1](#), [AVDDH\\_2](#) (monitored on [VDD25\\_REG\\_OUT](#))
- 3.3V - [VDD\\_OTP](#), [AVDDH\\_1](#), [AVDDH\\_2](#) (monitored on [VDD\\_OTP](#))

## 6.12.2 EXTERNAL CHIP RESET (RESET\_N)

A hardware reset will occur when the [RESET\\_N](#) pin is driven low. Assertion of [RESET\\_N](#) is not required at power-on. However, if used, [RESET\\_N](#) must be driven low for a minimum period as defined in [Section 7.6.4, "Reset Pin Configuration Strap Timing"](#). The [RESET\\_N](#) pin is not pulled-high internally and must be connected to [VDDVARIO](#) if unused.

**Note:** If configured, the EEPROM/OTP contents are reloaded by this reset. The configuration straps are also loaded by this reset.

## 6.12.3 PCIE FUNDAMENTAL RESET

The PCIe fundamental reset uses the [PERST#](#) pin, which indicates that the PCIe main power and reference clock are valid. It is used as a cold reset when the device operates from the main PCIe power source. It is used as a warm reset when the device operates from the auxiliary PCIe power source and indicates, to the still powered and operational device, that the main power and / or reference clock are not valid.

**Note:** Resets occur on the release of [PERST#](#), not on the active level.

### 6.12.3.1 Warm Reset

A warm reset occurs when the device is operating on auxiliary power or multiplexed main / auxiliary power ([VAUX\\_DET](#) pin = 1) and [PERST#](#) is asserted. The device enters the D3<sub>cold</sub> state. Warm reset is normally preceded by the PCIe link being placed into the L2/L3 Ready state. The D3<sub>cold</sub> state is exited when [PERST#](#) deasserts.

## 6.12.4 HOT RESETS

Hot resets include

- An in-band mechanism for propagating Conventional Reset across a Link
- An in-band mechanism for software to force a Link into Electrical Idle, disabling the Link
- The Data Link Layer reporting DL\_Down status.

## 6.12.5 FUNCTION-LEVEL RESET (FLR)

Function-Level Reset is a software issued reset triggered when the Initiate Function Level Reset bit in the PCIe Device Control configuration register is set. It is used to reset the device without affection the link state. An FLR starts, is processed and then exits.

During an FLR:

- All requests and completions for the function that arrived from the wire before the FLR started are handled by silently dropping them.
- All requests following the FLR are discarded using Unsupported Request (UR) (for posted and non-posted requests), and using Unexpected Completion (UC) for completions. Therefore, the software driver should put the function into a quiescent state (by clearing the BME or otherwise) before initiating an FLR so that the function does not issue requests in close proximity to the FLR event. Otherwise, any completions from these requests will be dropped later on.
- The function should not issue requests during FLR. Otherwise, completions from these requests (received by the device after the function has exited FLR) are treated as unexpected and dropped.
- Any outstanding INTx interrupt asserted by the function must be deasserted by sending the corresponding Deassert\_INTx Message.



- The device's non-PCIe functionality is reset.
- The FLR routine exits.

## 6.12.6 SOFT RESET

This is a software issued reset when the Soft Reset (SRST) bit in the Hardware Configuration Register (HW\_CFG) is set. It is used to completely reset the device as if it was a cold reset.

As with a POR and [RESET\\_N](#):

- The entire device is reset.
- A timer within the device will assert the internal reset for approximately 20 ms.
- The EEPROM/OTP contents are loaded by this reset.

**Note:** This reset will cause a detach from the PCIe bus, which may cause host software issues if unexpected.

## 6.12.7 SOFT-LITE RESET

This is a software issued reset when the Soft Lite Reset (LRST) bit in the Hardware Configuration Register (HW\_CFG) is set. It is used to reset only the device function without resetting the PCIe portion.

**Note:** Software must stop all RX and TX channels of the DMA controller before setting this bit.

Software must disable all interrupts before setting this bit.

Software must not access any device Control and Status Registers (PCIe Configuration Space registers excluded) for at least 5µs after setting Soft Lite Reset (LRST).

Software should verify that Soft Lite Reset (LRST) has self-cleared before performing any device operations or setting any device CSRs (PCIe Configuration Space registers excluded)

**APPLICATION NOTE:** Although some registers are returned to their last EEPROM or OTP specified default upon a Soft Like Reset (LRST), the device does not automatically reload its full configuration (including the User Initialization Table) from OTP or EEPROM. If necessary or desired, software may issue a Host Initiated EEPROM or OTP Reload.

## 6.12.8 POWER MANAGEMENT SOFT RESET

This reset is created when the device's power state is changed from D3<sub>hot</sub> to D0u by writing a 00b to the PowerState field in the Power Management Control/Status PCIe configuration register while the No\_Soft\_Reset field is clear.

## 6.12.9 ETHERNET PHY SOFTWARE RESET

The Ethernet PHY software reset is triggered via the Ethernet PHY Reset (ETH\_PHY\_RST) bit in the Power Management Control Register (PMT\_CTL). It holds the Ethernet PHY reset for a minimum of 2 ms.

For the LAN7431 (external Ethernet PHY), the [PHY\\_RESET\\_N](#) pin is asserted during this reset. The Device Ready (READY) bit in the Power Management Control Register (PMT\_CTL) asserts after the 2 ms [PHY\\_RESET\\_N](#) assertion interval completes. An optional 125ms delay can be enabled to allow for the external PHY to become ready. This is enabled with the External PHY Ready Delay Enable (EXT\_PHY\_RDY\_EN) bit.

For the LAN7430 (internal Ethernet PHY), the Device Ready (READY) asserts when the internal PHY is functional, following the reset.

**Note:** The Ethernet PHY Software Reset is not a chip-level reset. It resets only the Ethernet PHY.

## 6.12.10 EXTERNAL PHY RESET

The LAN7431 uses the dedicated [PHY\\_RESET\\_N](#) pin for automatically resetting the external Ethernet PHY. This pin automatically asserts as part of the reset sequence. The [PHY\\_RESET\\_N](#) may also be asserted by an [Ethernet PHY Software Reset](#).

# LAN7430/LAN7431

---

## 6.13 Power Management

The device supports two categories of Power Management (PM) operations to control the device state (D-state) and link state of the PCIe PHY and Endpoint Controller functional blocks.

Software PCI Compatible PM (PCI-PM) allows the host software to direct the function to enter into the D3<sub>hot</sub> and D3<sub>cold</sub> low-power states. This indirectly causes a change in the link power state. The L1 state is entered when the device is programmed to a non-D0 state. Further entry into L1.1 and L1.2 sub-states is initiated by the downstream port. Clock power management during the L1 state provides for the removal of the PCIe reference clock.

Native PCIe PM Mechanisms include Active State PM (ASPM) which, while in the L0 state, detects idle on the link for a specific time duration and automatically transitions the link to the L0s or L1 power states. L1 Sub-states are also supported that disables components on a link to further reduce idle power consumption while the link is in the L1 state, including almost complete removal of power for the high speed PHY circuits.

The power management functions include:

- Enabling the host to place the device in a reduced power state, by selectively disabling internal clocks and powering down the Ethernet PHY (LAN7430 only).
- Providing for detection of various wakeup events.
- Providing a host-readable READY flag which is set when the device is fully operational.
- Controlling the loading of OTP or EEPROM values after a system reset.
- Supporting D0 and D3<sub>hot</sub> and D3<sub>cold</sub> states
- Supporting L0s, L1 states and L1.1 and L1.2 Sub-states

Power Management Event (PME) functions include:

- Supporting PCIe WAKE# and Beaconsing.
- Supporting PCIe PME Messaging.
- Supporting GPIO, Link Change, Ethernet Frame as sources for wakeup.

### 6.13.1 PCIe DEVICE STATES

The device supports the mandatory D0 (herein referred to as D0u (uninitialized), D0a (active)), D3<sub>hot</sub>, and D3<sub>cold</sub> power states. The optional D1 and D2 states are not supported by the device.

The device can signal a wake event detection by sending a PME message and asserting wakeup via Beaconsing and the WAKE# pin. The PME messaging can be generated in all states, except the D0u and D3<sub>cold</sub> state. Wakeup via Beaconsing and the WAKE# pin can be generated in all states, including the D3<sub>cold</sub> state, except D0u.

The device can send PME messaging and assert wakeup upon detection of various power management events, such as an Ethernet “Wake On LAN”, Energy Efficient Ethernet activity, PHY link and energy detection and GPIO events. As a result, the host can reconfigure the power management state.

As a single function device, the device implements power management capabilities and power management control/status registers, which are mapped into the PCIe configuration space. The PME\_Support and Aux\_Current fields of the Power Management Capabilities register is dependent on the setting of the external VAUX\_DET pin. The Data\_Scale and Data\_Select fields of the Power Management Capabilities register will always return zero, as the Data Register is not implemented.

The descriptions that follow refer to the “PME Context”. PME Context is defined as:

- The PME\_Status and PME\_En fields in the PCIe Power Management Control/Status configuration register
- The Aux Power PM Enable field in the PCIe Device Control configuration register
- The Wakeup Source Register (WK\_SRC) register

Device power management states are directly controlled by software by writing the Power State field in the PCIe Power Management Control/Status configuration register.

In addition, the device utilizes two control signals. These are PERST#, to determine when main power is valid, and VAUX\_DET to determine if auxiliary power exists.

<b>Note:</b> If alternate usage of the VAUX_DET pin (e.g. GPIO3, LED3 or TMS) is enabled, the input value of the pin is overridden to a low value.
--

PME wakeup is enabled via the PME\_En field in the PCIe Power Management Control/Status configuration register. Although this does not directly affect the power state transitions, it does affect the allowable current draw while in certain states. As an alternate, the Aux Power PM Enable field in the PCIe Device Control configuration register also allows current draw while in certain states without enabling the PME function.

## 6.13.1.1 D0

D0 is divided into two distinct substates, the “un-initialized” substate and the “active” substate. When a component comes out of Conventional Reset, all Functions of the component enter the D0<sub>uninitialized</sub> (D0u) state. When a Function completes FLR, it enters the D0u state. After configuration is complete, a Function enters the D0<sub>active</sub> (D0a) state, the fully operational state for a PCI Express Function. A Function enters the D0a state whenever any single or combination of the Function’s Memory Space Enable, I/O Space Enable, or Bus Master Enable bits have been set.

**Note:** A Function remains in D0a even if these enable bits are subsequently cleared.

## 6.13.1.2 D3

D3 support is required (both the D3<sub>cold</sub> and the D3<sub>hot</sub> states). Functions supporting PME generation from D3 must support it for both D3<sub>cold</sub> and the D3<sub>hot</sub> states.

Functional context is required to be maintained by Functions in the D3<sub>hot</sub> state if the No\_Soft\_Reset field in the PCIe Power Management Control/Status configuration register is Set. In this case, software is not required to re-initialize the Function after a transition from D3<sub>hot</sub> to D0 (the Function will be in the D0<sub>active</sub> state). If the No\_Soft\_Reset bit is Clear, functional context is not required to be maintained by the Function in the D3<sub>hot</sub> state. As a result, in this case software is required to fully re-initialize the Function after a transition to D0 as the Function will be in the D0<sub>uninitialized</sub> state.

The Function will be reset if the Link state has transitioned to the L2/L3 Ready state regardless of the value of the No\_Soft\_Reset bit.

### 6.13.1.2.1 D3<sub>hot</sub>

While in the D3<sub>hot</sub> state, a Function must not initiate any Request TLPs on the Link with the exception of a PME Message. Completion TLPs may still be sent.

Configuration and Message requests are the only TLPs accepted by a Function in the D3<sub>hot</sub> state. All other received Requests must be handled as Unsupported Requests, and all received Completions may optionally be handled as Unexpected Completions.

If an error caused by a received TLP (e.g., an Unsupported Request) is detected while in D3<sub>hot</sub>, and reporting is enabled, the Link must be returned to L0 if it is not already in L0 and an error Message must be sent. If an error caused by an event other than a received TLP (e.g., a Completion Timeout) is detected while in D3<sub>hot</sub>, an error Message may optionally be sent when the Function is programmed back to the D0 state. Once in D3<sub>hot</sub> the Function can later be transitioned into D3<sub>cold</sub> (by removing power from its host component).

Note that D3<sub>hot</sub> is also a useful state for reducing power consumption by idle components in an otherwise running system.

### 6.13.1.2.2 D3<sub>cold</sub>

A Function transitions to the D3<sub>cold</sub> state when its main power is removed. A power-on sequence with its associated cold reset transitions a Function from the D3<sub>cold</sub> state to the D0<sub>uninitialized</sub> state. At this point, software must perform a full initialization of the Function in order to re-establish all functional context, completing the restoration of the Function to its D0<sub>active</sub> state. This device has the option to reset only the PCIe controller and maintain the device’s functional context.

Functions that support wakeup functionality from D3<sub>cold</sub> must maintain their PME context for inspection by PME service routine software during the course of the resume process. A Function’s PME assertion is acknowledged when system software performs a “write 1 to clear” configuration transaction to the asserting Function’s PME\_Status bit of its PCI-PM compatible PCIe Power Management Control/Status configuration register.

An auxiliary power source must be used to support PME event detection within a Function, Link reactivation, and to preserve PME context from within D3<sub>cold</sub>. Note that once the I/O Hierarchy has been brought back to a fully communicating state, as a result of the Link reactivation, the waking agent then propagates a PME Message to the root of the Hierarchy indicating the source of the PME event.

# LAN7430/LAN7431

---

## 6.13.2 PCIe LINK STATES (LOW POWER SUB-STATES)

The link states are not visible to PCI-PM legacy compatible software and are either derived from the power management D-states of the corresponding components connected to that Link or by ASPM protocols.

The PCIe specification describes the rules and conditions for entry and exit of the link states.

The device supports the following Link power management states:

### **L0 - Active state**

In this state, the main power supplies, reference clocks and the devices internal PLL are active. The platform's Vaux may or may not be active.

All PCI Express transactions and other operations are enabled.

L0 support is required for both ASPM and PCI-PM compatible power management.

L0 is available while in D0. It is also temporarily used in D3<sub>hot</sub> for messages during this state.

### **L0s – A low resume latency, energy saving “standby” state**

In this state, the main power supplies, reference clocks and the devices internal PLL are active. The platform's Vaux may or may not be active.

TLP and DLLP transmission is disabled for a Port whose Link is in Tx\_L0s.

The Physical Layer provides mechanisms for quick transitions from this state to the L0 state. When common (distributed) reference clocks are used on both sides of a Link, the transition time from L0s to L0 is typically less than 100 Symbol Times.

It is possible for the Transmit side of one component on a Link to be in L0s while the Transmit side of the other component on the Link is in L0.

L0s is not applicable to PCI-PM compatible power management and is optionally used by ASPM power management.

L0s is only available while in D0.

### **L1 – Higher latency, lower power “standby” state**

In this state, the main power supplies are active. Reference clocks must remain active during L1, except as permitted by Clock Power Management (using CLKREQ#) and/or L1 PM Sub-states when enabled. The devices internal PLL is active, based on the availability of the reference clock. The platform's Vaux may or may not be active.

TLP and DLLP transmission is disabled for a Link in L1.

Two power management Messages provide support for the PCI-PM L1 state:

- PM\_Enter\_L1 (DLLP)
- PM\_Request\_Ack (DLLP)

The L1 state is entered whenever all Functions of a Downstream component on a given Link are programmed to a D-state other than D0. It may also be optionally entered by ASPM power management while in the D0 state.

The PCIe specification describes the rules for entry and exit of the link states. Exit from L1 is initiated by an Upstream-initiated transaction targeting a Downstream component, or by the Downstream component's initiation of a transaction heading Upstream. Transition from L1 to L0 is typically a few microseconds.

L1 support is required for PCI-PM compatible power management and is optionally used by ASPM.

#### *L1 Clock Power Management*

If L1 Sub-states (below) are not enabled, the reference clock may still be removed and the PLL turned off. This function is controlled by the Enable Clock Power Management field in the PCIe Link Control configuration register. Software must only set this field if the Clock Power Management bit of the Link Capabilities register is a 1.

L1 Clock PM and L1 Sub-states work orthogonal to each other. However, L1 Sub-states takes precedence over Clock PM. This means that when the entry conditions for any L1 Sub-state are satisfied then the device executes the corresponding L1 Substate protocol.

**L1 PM Sub-states** – optional L1.1 and L1.2 sub-states of the L1 low power Link state for PCI-PM and ASPM are supported by the device.

## L1.0 Sub-state

This sub-state corresponds to the conventional L1 Link state, when L1 PM Sub-states are enabled by setting one or more of the enable bits in the PCIe L1 PM Substates Control 1 configuration register but the device is not in either of those sub-states.

This sub-state is entered whenever the Link enters L1.

The port is required to be enabled to detect Electrical Idle and the Link common mode voltages are maintained.

## L1.1 Sub-state

The port is not required to be enabled to detect Electrical Idle but the Link common mode voltages are maintained.

The bidirectional open-drain clock request (CLKREQ#) signal controls entry and exit from this state. After the link has entered L1 through the normal L1 negotiation, the device can initiate the sequence for entering L1.1 by three-stating the CLKREQ# output buffer. The entry sequence can only proceed if the DSP is also three-stating its CLKREQ# output buffer, resulting in the bidirectional CLKREQ# signal being pulled up to 1. Otherwise CLKREQ# will remain asserted at 0 and the link state will stay in L1.0.

The exit sequence can be initiated by either port by asserting CLKREQ# to 0.

## L1.2 Sub-state

The port is not required to be enabled to detect Electrical Idle nor maintain the Link common mode voltages.

The bidirectional open-drain clock request (CLKREQ#) signal controls entry and exit from this state. After the link has entered L1 through the normal L1 negotiation, the device can initiate the sequence for entering L1.2 by three-stating the CLKREQ# output buffer. The entry sequence can only proceed if the DSP is also three-stating its CLKREQ# output buffer, resulting in the bidirectional CLKREQ# signal being pulled up to 1. Otherwise CLKREQ# will remain asserted at 0 and the link state will stay in L1.0.

The exit sequence can be initiated by either port by asserting CLKREQ# to 0.

L1.2 is further subdivided into L1.2.Entry, L1.2.Idle and L1.2.Exit.

[Table 6-2](#) details the various L1 sub-state exit latencies.

**TABLE 6-2: L1 SUB-STATE EXIT LATENCIES**

L1 Sub-state	Exit Latency (uS)
L1	<7
L1 with CLKREQ# (CPM)	<68
L1.1	<68
L1.2	<88

### 6.13.3 LATENCY TOLERANCE REPORTING (LTR) MECHANISM

The Latency Tolerance Reporting (LTR) mechanism enables the endpoint to report the service latency requirements for Memory Reads and Writes to the Root Complex. Power management policies for central platform resources (such as main memory, RC internal interconnects, and snoop resources) can be implemented to consider the endpoint service requirements. The Root Complex is not required to honor the requested service latencies, but is strongly encouraged to provide a worst case service latency that does not exceed the latencies indicated by the LTR mechanism.

This device supports LTR as indicated by the LTR Mechanism Supported bit in the PCIe Device Capabilities 2 configuration register. LTR is enabled via the LTR Mechanism Enable bit in the PCIe Device Control 2 configuration register.

The LTR mechanism tells the host the latency tolerance the device has in response to a request from the device. This allows the host to judiciously decide how long to wait before servicing the interrupt from the device. System power consumption is optimized by enabling the Host CPU and memory sub-system to utilize the device's latency, and power down and stay in their low power states longer.

# LAN7430/LAN7431

---

## 6.14 Integrated Voltage Regulators

The LAN7430/LAN7431 includes both a switching regulator and LDO to facilitate ease of integration and to allow operation off of a single power supply.

### 6.14.1 SWITCHING REGULATOR

The switching regulator supplies 1.2 volts to the main core digital logic, the I/O pads and the Gigabit Ethernet PHY's digital logic, all via the **VDD12CORE** inputs. It also supplies the 1.2V power to the Gigabit Ethernet PHY's analog sections and the PCIe PHY's analog, digital and transmit sections, all via external connections. It operates from a 1.8V to 3.3V input supply and can supply up to 600mA output current.

When the **VDD12\_SW\_FB** pin is connected to the 1.2V regulated voltage, the switching regulator is enabled and receives 1.8V to 3.3V on the **VDD\_SW\_IN** pin.

The switching regulator requires an external LC filter to generate the 1.2V regulated voltage. A 3.3uH inductor should be connected between the switching regulator's output, **VDD12\_SW\_OUT** pin, and the 1.2V regulated supply. A 10uF ceramic capacitor, along with a noise filtering 0.1uF ceramic, should be connected from the 1.2V regulated supply to ground.

Over-Current Protection and Short-Circuit Protection are supported.

The switching regulator can be disabled to allow for an external 1.2V supply. When the **VDD12\_SW\_FB** pin is connected to the **VDD\_SW\_IN** pin, the switching regulator is disabled. However, 1.8V to 3.3V must still be supplied to the **VDD\_SW\_IN** pin.

Refer to [Section 4.0, "Power Connectivity"](#) for additional details.

### 6.14.2 LOW-DROPOUT REGULATOR

The LDO regulator supplies 2.5 volts to the PCIe PHY and the Gigabit Ethernet PHY, all via external connections. It operates from a 3.3V input supply and can supply up to 250mA output current. The Gigabit Ethernet PHY can alternatively be powered by an external 3.3V supply.

When the **VDD\_REG\_IN** pin is connected to 3.3V, the LDO regulator is enabled. A 1.0 uF 0.1-ohm ESR capacitor must be connected to the **VDD25\_REG\_OUT** pin.

The LDO regulator can be bypassed to allow for an external 2.5V supply. When the **VDD25\_REG\_OUT** pin is connected to the **VDD\_REG\_IN** pin, the LDO regulator is disabled. However, 2.5V must still be supplied to the **VDD\_REG\_IN** pin.

Refer to [Section 4.0, "Power Connectivity"](#) for additional details.

## 6.15 JTAG

The integrated IEEE 1149.1 compliant TAP Controller supports boundary scan and various test modes via the JTAG test port. The interface consists of four pins (**TDO**, **TDI**, **TCK** and **TMS**) and includes a state machine, data register array, and an instruction register. The JTAG pins are described in [Table 3-3, "Pin Descriptions," on page 16](#). The JTAG interface conforms to the IEEE Standard 1149.1 - 2001 Standard Test Access Port (TAP) and Boundary-Scan Architecture.

All input and output data is synchronous to the **TCK** test clock input. TAP input signals **TMS** and **TDI** are clocked into the test logic on the rising edge of **TCK**, while the output signal **TDO** is clocked on the falling edge.

The JTAG functionality is selected when the **TEST** pin is asserted. The implemented IEEE 1149.1 instructions and their op codes are shown in [Table 6-3](#). The JTAG IDs for each version of the device are shown in [Table 6-4](#). Refer to [Section 7.6.8, "JTAG Timing"](#) for detailed JTAG timing specifications.

**TABLE 6-3: IEEE 1149.1 OP CODES**

Instruction	Op Code	Comment
BYPASS 0	28'h0000000	Mandatory Instruction
BYPASS 1	28'hFFFFFFF	Mandatory Instruction
SAMPLE / PRELOAD	28'hFFFFFFF8	Mandatory Instruction
EXTEST	28'hFFFFFFE8	Mandatory Instruction
CLAMP	28'hFFFFFFEF	Optional Instruction
ID_CODE	28'hFFFFFFFE	Optional Instruction
HIGHZ	28'hFFFFFFCF	Optional Instruction

**TABLE 6-4: JTAG ID**

Device	JTAG ID
LAN7430	001E1445h
LAN7431	001F1445h

## 6.16 Miscellaneous

### 6.16.1 GENERAL PURPOSE INPUTS/OUTPUTS (GPIOs)

The GPIO controller is comprised of 4 (for the LAN7430) or 12 (for the LAN7431) programmable input / output pins (**GPIO[11:0]**). These pins are individually configurable via the GPIO configuration registers. Push/pull and open-drain output buffers are supported for each GPIO. When a GPIO pin is set to an output, the input buffer and pull-up are disabled. When a GPIO pin is set as an input, the pull-up is enabled. Each GPIO has the ability to be used as a 1588 input or output.

**Note:** Internal pull-up resistors prevent unconnected inputs from floating. Do not rely on internal resistors to drive signals external to the device. When connected to a load that must be pulled high, an external resistor must be added.

### 6.16.2 GENERAL PURPOSE TIMER (GPT)

The device includes a programmable general purpose timer that can be used to generate periodic system interrupts. The resolution of this timer is 100uS. The GPT is loaded and enabled via the General Purpose Timer Configuration Register. Once the enabled general purpose timer counts down to zero, the general purpose timer interrupt is asserted to alert the user.

# LAN7430/LAN7431

## 7.0 OPERATIONAL CHARACTERISTICS

### 7.1 Absolute Maximum Ratings\*

Supply Voltage (VDDVARIO, VDDVARIO_B, VDD_SW_IN, VDD_REG_IN, VDD_OTP) (Note 7-1)	.....	-0.5 V to +4.6 V
+2.5/3.3 V Analog Supply Voltage (AVDDH_1, AVDDH_2) (Note 7-1)	.....	-0.5 V to +4.6 V
+2.5 V Analog Supply Voltage (VPH) (Note 7-1)	.....	-0.5 V to +3.2 V
+1.2 V Analog Supply Voltage (AVDD12, AVDDL_1, AVDDL_2, VPTX, VP) (Note 7-1)	.....	-0.5 V to +1.5 V
+1.2 V Digital Supply Voltage (VDD12CORE) (Note 7-1)	.....	-0.5 V to +1.5 V
Positive voltage on input signal pins, with respect to ground	.....	+4.6 V
Negative voltage on input signal pins, with respect to ground	.....	-0.5 V
Storage Temperature	.....	-65°C to +150°C
Lead Temperature Range	.....	Refer to JEDEC Spec. J-STD-020
HBM ESD Performance	.....	+/-2kV

**Note 7-1** When powering this device from laboratory or system power supplies, it is important that the absolute maximum ratings not be exceeded or device failure can result. Some power supplies exhibit voltage spikes on their outputs when AC power is switched on or off. In addition, voltage transients on the AC power line may appear on the DC output. If this possibility exists, it is suggested that a clamp circuit be used.

\*Stresses exceeding those listed in this section could cause permanent damage to the device. This is a stress rating only. Exposure to absolute maximum rating conditions for extended periods may affect device reliability. Functional operation of the device at any condition exceeding those indicated in [Section 7.2, "Operating Conditions\\*\\*"](#), [Section 7.5, "DC Specifications"](#), or any other applicable section of this specification is not implied.

### 7.2 Operating Conditions\*\*

Supply Voltage (VDD_SW_IN)	.....	+1.62 V to +3.63 V
Supply Voltage (VDDVARIO, VDDVARIO_B)	.....	+1.62 V to +3.63 V
Supply Voltage (VDD_REG_IN, VDD_OTP)	.....	+2.97 V to +3.63 V
+2.5/3.3 V Ethernet PHY Analog Supply Voltage (AVDDH_1, AVDDH_2)	.....	<a href="#">Note 7-2</a> +2.33 V to +2.75 V +2.97 V to +3.63 V
+2.5 V PCIe PHY Analog Supply Voltage (VPH)	.....	+2.33 V to +2.75 V
+1.2 V PCIe PHY Analog Supply Voltage (VPTX, VP)	.....	+1.12 V to +1.32 V
+1.2 V Ethernet PHY Analog Supply Voltage (AVDD12, AVDDL_1, AVDDL_2)	.....	+1.14 V to +1.32 V
Digital Supply Voltage (VDD12CORE)	.....	+1.14 V to +1.32 V
Positive voltage on input signal pins, with respect to ground	.....	+3.63 V
Negative voltage on input signal pins, with respect to ground	.....	-0.3 V
Ambient Operating Temperature in Still Air (T <sub>A</sub> )	.....	<a href="#">Note 7-3</a>

**Note 7-2** The 10BASE-T transmit amplitude will not pass the 10BASE-T spec limits over process, voltage, and temperature at 2.5V (nominal).

**Note 7-3** 0°C to +70°C for commercial version, -40°C to +85°C for industrial version, -40°C to +105°C for automotive version.



## 7.3 Package Thermal Specifications

### 7.3.1 48-SQFN (LAN7430 ONLY)

**TABLE 7-1: 48-SQFN PACKAGE THERMAL PARAMETERS**

Symbol	°C/W	Velocity (Meters/s)
$\Theta_{JA}$	26.4	0
	23.1	1
$\Psi_{JT}$	0.2	0
	0.3	1
$\Theta_{JC}$	1.8	N/A

**Note:** Thermal parameters are measured or estimated for devices in a multi-layer 2S2P PCB per JESDN51.

### 7.3.2 72-SQFN (LAN7431 ONLY)

**TABLE 7-2: 72-SQFN PACKAGE THERMAL PARAMETERS**

Symbol	°C/W	Velocity (Meters/s)
$\Theta_{JA}$	20.6	0
	18.0	1
$\Psi_{JT}$	0.1	0
	0.2	1
$\Theta_{JC}$	1.6	N/A

**Note:** Thermal parameters are measured or estimated for devices in a multi-layer 2S2P PCB per JESDN51.

# LAN7430/LAN7431

## 7.4 Power Consumption

### 7.4.1 LAN7430 POWER CONSUMPTION

**TABLE 7-3: LAN7430 POWER CONSUMPTION**

Mode		3.3V Typical Current (mA)	Typical Power (mW)	
Suspend	Without WoL support	44	145	
	WoL - 1000BASE-T	208	686	
	WoL - 100BASE-TX	107	353	
	WoL - 10BASE-Te	57	188	
	WoL - 100BASE-TX EEE	76	251	
	WoL - 1000BASE-T EEE	70	231	
1000BASE-T	Active Operation	L0s	284	936
		L1	273	901
		L1 with CPM	252	832
		L1.SS	247	814
	Idle	L0s	281	927
		L1	255	842
		L1 with CPM	232	766
		L1.SS	230	759
	Idle w/EEE	L0s	133	439
		L1	105	347
		L1 with CPM	86	284
		L1.SS	85	281
100BASE-TX	Active Operation	L0s	173	572
		L1	147	485
		L1 with CPM	134	444
		L1.SS	132	437
	Idle	L0s	173	571
		L1	144	475
		L1 with CPM	125	413
		L1.SS	124	409
	Idle w/EEE	L0s	139	459
		L1	111	366
		L1 with CPM	92	304
		L1.SS	91	300
10BASE-Te	Active Operation	L0s	126	416
		L1	105	347
		L1 with CPM	82	270
		L1.SS	81	267
	Idle	L0s	118	389
		L1	91	300
		L1 with CPM	72	238
		L1.SS	71	234

# LAN7430/LAN7431

**TABLE 7-3: LAN7430 POWER CONSUMPTION (CONTINUED)**

Mode		3.3V Typical Current (mA)	Typical Power (mW)
Energy Detect Power Down	L0s	105	347
	L1	79	260
	L1 with CPM	59	194
	L1.SS	58	191

## 7.4.2 LAN7431 POWER CONSUMPTION

**TABLE 7-4: LAN7431 POWER CONSUMPTION**

Mode		Typical Current (mA)	Typical Power (mW)	
RGMII 100BASE-T	VDDVARIO	1.8V	23	41
		2.5V	33	83
		3.3V	38	125
	3.3V (VDD_SW_IN, VDD_REG_IN, VDD_OTP)	L0s	90	297
		L1	75	248
		L1 with CPM	63	208
		L1.SS	62	205
RGMII 100BASE-TX	VDDVARIO	1.8V	6	11
		2.5V	8	20
		3.3V	11	36
	3.3V (VDD_SW_IN, VDD_REG_IN, VDD_OTP)	L0s	90	297
		L1	75	248
		L1 with CPM	63	208
		L1.SS	62	205
RGMII 10BASE-Te	VDDVARIO	1.8V	2	4
		2.5V	3	8
		3.3V	5	17
	3.3V (VDD_SW_IN, VDD_REG_IN, VDD_OTP)	L0s	90	297
		L1	65	215
		L1 with CPM	50	165
		L1.SS	49	162
MII 100BASE-TX	VDDVARIO	1.8V	2	4
		2.5V	3	8
		3.3V	8	26
	3.3V (VDD_SW_IN, VDD_REG_IN, VDD_OTP)	L0s	90	297
		L1	75	248
		L1 with CPM	63	208
		L1.SS	62	205

# LAN7430/LAN7431

**TABLE 7-4: LAN7431 POWER CONSUMPTION (CONTINUED)**

Mode		Typical Current (mA)	Typical Power (mW)	
MII 10BASE-Te	VDDVARIO	1.8V	4	
		2.5V	8	
		3.3V	26	
	3.3V (VDD_SW_IN, VDD_REG_IN, VDD_OTP)	L0s	90	297
		L1	65	215
		L1 with CPM	50	165
		L1.SS	49	162

## 7.5 DC Specifications

**TABLE 7-5: NON-VARIABLE I/O DC ELECTRICAL CHARACTERISTICS**

Parameter	Symbol	Min	Typ	Max	Units	Notes
IS Type Input Buffer						
Low Input Level	$V_{IL}$			0.8	V	Schmitt trigger
High Input Level	$V_{IH}$	2.0			V	Schmitt trigger
Schmitt Trigger Hysteresis ( $V_{IHT} - V_{ILT}$ )	$V_{HYS}$	100	127	245	mV	
Input Leakage ( $V_{IN} = VSS$ or $VDD\_OTP$ )	$I_{IH}$	-10		10	$\mu A$	Note 7-4
Input Capacitance	$C_{IN}$		2	3	pF	
OD4 Type Buffer						
Low Output Level	$V_{OL}$			0.2	V	$I_{OL} = -4$ mA
ICLK Type Input Buffer						
Low Input Level	$V_{IL}$			0.5	V	Note 7-5
High Input Level	$V_{IH}$	2.0			V	
Input Leakage	$I_{IH}$	-10		10	$\mu A$	

**Note 7-4** This specification applies to all inputs and tri-stated bi-directional pins.

**Note 7-5** XI can optionally be driven from a 25 MHz single-ended clock oscillator to which these specifications apply.

# LAN7430/LAN7431

**TABLE 7-6: VARIABLE I/O DC ELECTRICAL CHARACTERISTICS**

Parameter	Symbol	Min	Typ 1.8	Typ 2.5	Typ 3.3	Max	Units	Notes
VIS Type Input Buffer								
Low Input Level	$V_{IL}$					$0.39 \cdot V_{DDVARIO}$	V	
High Input Level	$V_{IH}$	$0.63 \cdot V_{DDVARIO}$					V	
Schmitt Falling Trip Point	$V_{T-}$	0.67	0.80	1.09	1.42	1.61	V	Schmitt trigger
Schmitt Rising Trip Point	$V_{T+}$	0.81	0.94	1.22	1.54	1.74	V	Schmitt trigger
Schmitt Trigger Hysteresis ( $V_{IHT} - V_{ILT}$ )	$V_{HYS}$	100	141	123	127	245	mV	
Input Leakage ( $V_{IN} = VSS$ or $VDDVARIO$ )	$I_{IH}$	-10				10	$\mu A$	Note 7-6
Input Capacitance	$C_{IN}$		2	2	2	3	pF	
Pull-Up Impedance ( $V_{IN} = VSS$ )	$R_{DPU}$	59.1	70	70	70	82.1	K $\Omega$	
Pull-Up Current ( $V_{IN} = VSS$ )	$I_{DPU}$	19.7	26	36	47	61.4	$\mu A$	
Pull-Down Impedance ( $V_{IN} = VDDVARIO$ )	$R_{DPD}$	59.4	70	70	70	82.7	K $\Omega$	
Pull-Down Current ( $V_{IN} = VDDVARIO$ )	$I_{DPD}$	19.7	26	36	47	61.1	$\mu A$	
VO8 Type Buffer								
Low Output Level	$V_{OL}$					0.4	V	$I_{OL} = -8$ mA
High Output Level	$V_{OH}$	$V_{DDVARIO} - 0.4$					V	$I_{OH} = 8$ mA
VOD8 Type Buffer								
Low Output Level	$V_{OL}$					0.4	V	$I_{OL} = -8$ mA
VO12 Type Buffer								
Low Output Level	$V_{OL}$					0.4	V	$I_{OL} = -12$ mA
High Output Level	$V_{OH}$	$V_{DDVARIO} - 0.4$					V	$I_{OH} = 12$ mA
VOD12 Type Buffer								
Low Output Level	$V_{OL}$					0.4	V	$I_{OL} = -12$ mA
VOS12 Type Buffer								
High Output Level	$V_{OH}$	$V_{DDVARIO} - 0.4$					V	$I_{OH} = 12$ mA

# LAN7430/LAN7431

**TABLE 7-6: VARIABLE I/O DC ELECTRICAL CHARACTERISTICS (CONTINUED)**

Parameter	Symbol	Min	Typ 1.8	Typ 2.5	Typ 3.3	Max	Units	Notes
RGMII_I Type Buffer								
Low Input Level	$V_{IL}$					$0.4 \cdot V_{DDVARIO}$	V	
High Input Level	$V_{IH}$	$0.6 \cdot V_{DDVARIO}$					V	
Schmitt Falling Trip Point	$V_{T-}$	0.74	0.89	1.08	1.39	1.57	V	Schmitt trigger
Schmitt Rising Trip Point	$V_{T+}$	0.84	0.96	1.18	1.50	1.69	V	Schmitt trigger
Schmitt Trigger Hysteresis ( $V_{IHT} - V_{ILT}$ )	$V_{HYS}$	58	66	110	122	150	mV	
Input Leakage ( $V_{IN} = V_{SS}$ or $V_{DDVARIO}$ )	$I_{IH}$	-15				15	$\mu A$	
Input Capacitance	$C_{IN}$		2	2	2	3	pF	
RGMII_O Type Buffer								
Low Output Level	$V_{OL}$					0.4	V	$I_{OL} = -6 \text{ mA}$
High Output Level	$V_{OH}$	$0.7 \cdot V_{DDVARIO}$					V	$I_{OH} = 6 \text{ mA}$
Output Impedance	$R_O$		50	50	50		$\Omega$	

**Note 7-6** This specification applies to all inputs and three-stated bi-directional pins.

**TABLE 7-7: 1000BASE-T TRANSCEIVER CHARACTERISTICS**

Parameter	Symbol	Min	Typ	Max	Units	Notes
Peak Differential Output Voltage IEEE 802.3 clause 40.6.1.2.1	$V_{OP}$	670		820	mV	Note 7-7
Signal Amplitude Symmetry IEEE 802.3 clause 40.6.1.2.1	$V_{SS}$			1	%	Note 7-7
Signal Scaling IEEE 802.3 clause 40.6.1.2.1	$V_{SC}$			2	%	Note 7-8
Output Droop IEEE 802.3 clause 40.6.1.2.2	$V_{OD}$	73.1			%	Note 7-7
Transmission Distortion IEEE 802.3 clause 40.6.1.2.4				10	mV	Note 7-9

**Note 7-7** IEEE 802.ab Test Mode 1

**Note 7-8** From 1/2 of average  $V_{OP}$ , Test Mode 1

**Note 7-9** IEEE 802.ab distortion processing

# LAN7430/LAN7431

**TABLE 7-8: 100BASE-TX TRANSCEIVER CHARACTERISTICS**

Parameter	Symbol	Min	Typ	Max	Units	Notes
Peak Differential Output Voltage ANSI X3.263 clause 9.1.2.2	$V_{OUT}$	$\pm 0.95$	-	$\pm 1.05$	V	Note 7-10
Signal Amplitude Symmetry ANSI X3.263 clause 9.1.4	$V_{SS}$		-	2	%	Note 7-10
Signal Rise and Fall Time ANSI X3.263 clause 9.1.6	$T_{RF}$	3	-	5	nS	Note 7-10
Rise and Fall Symmetry ANSI X3.263 clause 9.1.6	$T_{RFS}$	-	-	0.5	nS	Note 7-10
Duty Cycle Distortion ANSI X3.263 clause 9.1.8	$D_{CD}$			$\pm 0.25$	nS	Note 7-11
Overshoot and Undershoot ANSI X3.263 clause 9.1.3	$V_{OS}$	-	-	5	%	
Output Jitter ANSI X3.263 clause 9.1.9			0.7	1.4	nS	Note 7-12
Reference Voltage of ISET (using 6.04k $\Omega$ - 1% resistor)	$V_{SET}$		0.65		V	

**Note 7-10** Measured at line side of transformer, line replaced by 100 $\Omega$  (+/- 1%) resistor.

**Note 7-11** Offset from 16nS pulse width at 50% of pulse peak.

**Note 7-12** Peak to Peak, measured differentially.

**TABLE 7-9: 10BASE-T/10BASE-Te TRANSCEIVER CHARACTERISTICS**

Parameter	Symbol	Min	Typ	Max	Units	Notes
Transmitter Peak Differential Output Voltage IEEE 802.3 clause 14.3.1.2.1	$V_{OUT}$ 10BASE-T	2.2	2.5	2.8	V	Note 7-13
	$V_{OUT}$ 10BASE-Te	1.54		1.96	V	Note 7-13
Output Jitter IEEE 802.3 clause 14.3.1.2.3			1.8	3.5	nS	Note 7-14
Signal Rise and Fall Time	$T_{RF}$		25		nS	
Receiver Differential Squelch Threshold IEEE 802.3 clause 14.3.1.3.2	$V_{DS}$	300	400		mV	Note 7-15

**Note 7-13** Min/max voltages guaranteed as measured with 100 $\Omega$  resistive load.

**Note 7-14** Measured differentially following the twisted-pair model with a 100 $\Omega$  resistive load.

**Note 7-15** 5MHz square wave.

**TABLE 7-10: PCIe TRANSCEIVER CHARACTERISTICS**

Parameter	Symbol	Min	Typ	Max	Units	Notes
Receiver Input Leakage (terminations off)	$I_{II}$			2	$\mu$ A	
Transmitter Input Leakage	$I_{II}$			25	$\mu$ A	
PCIe Clock Input Leakage	$I_{II}$			32	nA	

# LAN7430/LAN7431

## 7.6 AC Specifications

This section details the various AC timing specifications of the device.

**Note:** The MII timing adheres to or exceeds the IEEE 802.3 specification. Refer to the IEEE 802.3 specification for additional MII timing information.

**Note:** The RGMII timing adheres to or exceeds the HP RGMII Specification Version 2.0. Refer to this specification for additional RGMII timing information.

### 7.6.1 EQUIVALENT TEST LOAD

Output timing specifications assume a 25pF equivalent test load, unless otherwise noted, as illustrated in [Figure 7-1](#).

**FIGURE 7-1: OUTPUT EQUIVALENT TEST LOAD**

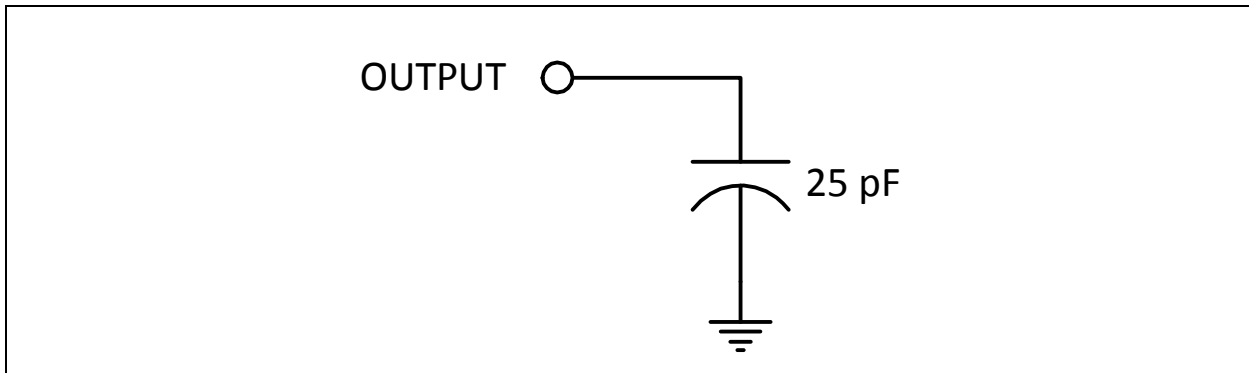

### 7.6.2 POWER SEQUENCE TIMING

This section details the device power sequencing requirements. The [VDDVARIO](#), [VDDVARIO\\_B](#), [VDD\\_SW\\_IN](#), [VDD\\_REG\\_IN](#), [VDD\\_OTP](#), [AVDDH\\_1](#) and [AVDDH\\_2](#) power supplies must all reach operational levels within the specified time period  $t_{pon}$ , as shown in [Figure 7-2](#). When operating with the internal regulators disabled, [VDD12CORE](#), [AVDD12](#), [AVDDL\\_1](#), [AVDDL\\_2](#), [VPH](#), [VPTX](#) and [VP](#) are also included in this requirement, as shown in [Figure 7-3](#).

In addition, all of the power supplies must reach 80% of their operating voltage level within 15ms. This requirement can be safely ignored if using an external reset as shown in [Section 7.6.4](#).

Device power supplies can turn off in any order provided they all reach 0 volts within the specified time period  $t_{poff}$ .

**FIGURE 7-2: POWER SEQUENCE TIMING (INTERNAL REGULATORS)**

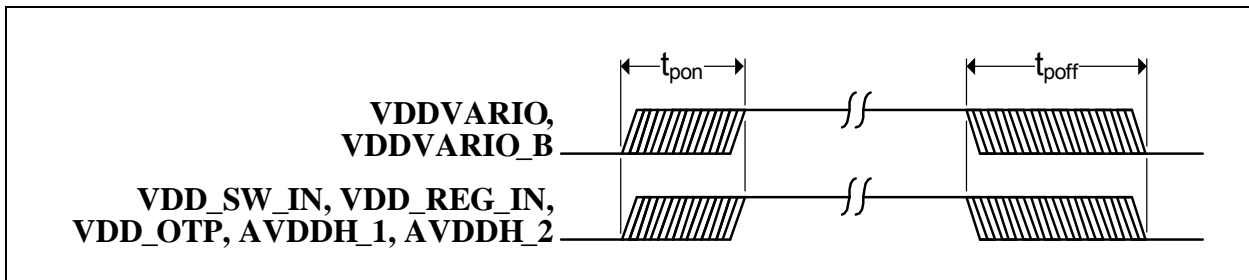



**FIGURE 7-3: POWER SEQUENCE TIMING (EXTERNAL REGULATORS)**

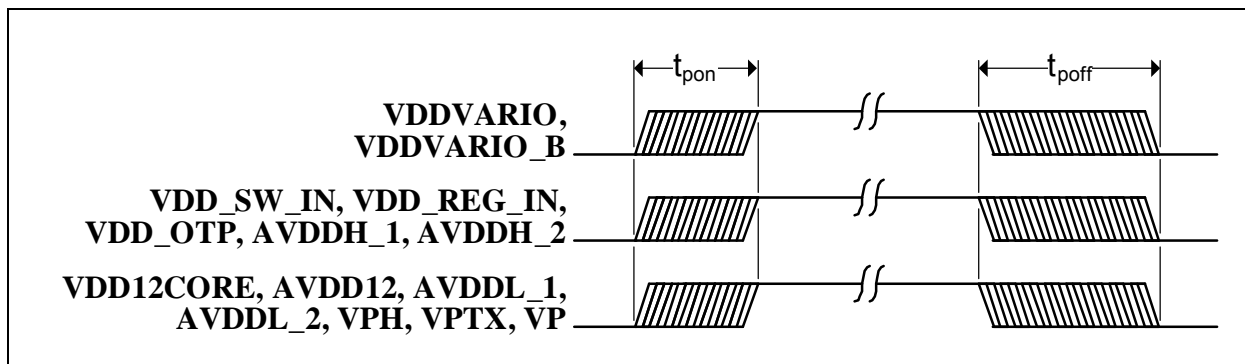

**TABLE 7-11: POWER SEQUENCING TIMING VALUES**

Symbol	Description	Min	Typ	Max	Units
$t_{pon}$	Power supply turn on time			50	ms
$t_{poff}$	Power supply turn off time			500	ms

### 7.6.3 POWER-ON CONFIGURATION STRAP TIMING

Figure 7-4 illustrates the configuration strap timing requirements, in relation to power-on, for applications where RESET\_N is not used at power-on. The operational level ( $V_{opp}$ ) for the external power supply is detailed in Section 7.2, "Operating Conditions\*\*," on page 48.

**FIGURE 7-4: POWER-ON CONFIGURATION STRAP TIMING**

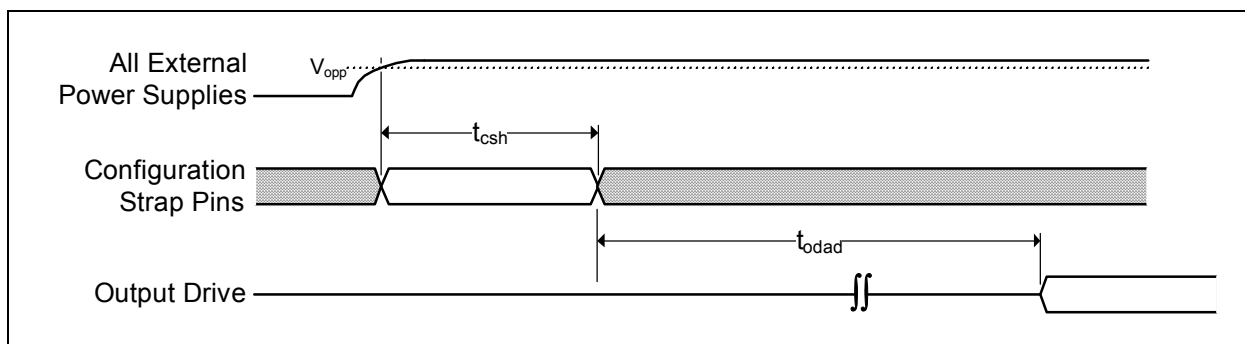

**TABLE 7-12: POWER-ON CONFIGURATION STRAP TIMING**

Symbol	Description	Min	Typ	Max	Units
$t_{csh}$	Configuration strap hold after external power supply at operational level	22			ms
$t_{odad}$	Output drive after straps latched	3			$\mu$ s

# LAN7430/LAN7431

## 7.6.4 RESET PIN CONFIGURATION STRAP TIMING

Figure 7-5 illustrates the **RESET\_N** timing requirements and its relation to the configurations traps. Assertion of **RESET\_N** is not a requirement. However, if used, it must be asserted for the minimum period specified.

**FIGURE 7-5: RESET\_N CONFIGURATION STRAP TIMING**

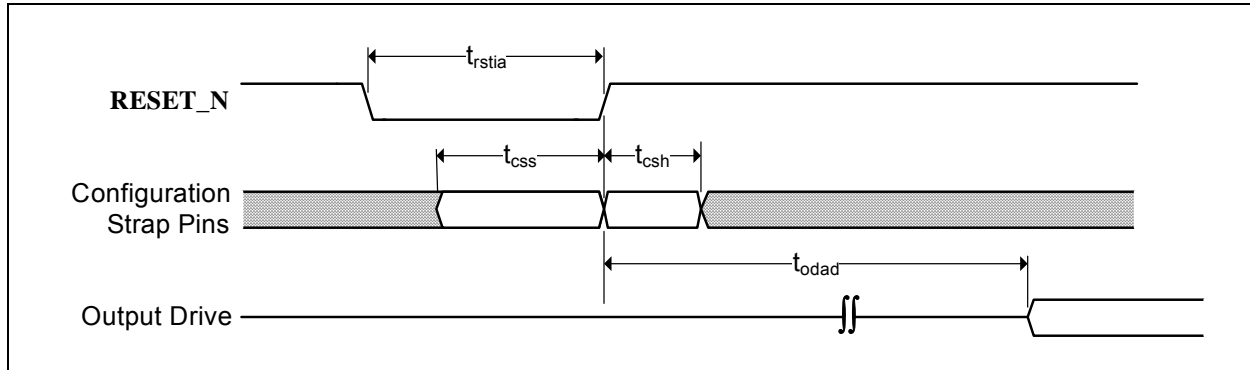

**TABLE 7-13: RESET\_N CONFIGURATION STRAP TIMING**

Symbol	Description	Min	Typ	Max	Units
$t_{rstia}$	<b>RESET_N</b> input assertion time	1			us
$t_{css}$	Configuration strap setup before <b>RESET_N</b> deassertion	200			ns
$t_{csh}$	Configuration strap hold after <b>RESET_N</b> deassertion	10			ns
$t_{odad}$	Output drive after <b>RESET_N</b> deassertion	3			$\mu$ s

## 7.6.5 MII TIMING (100BASE-TX, 10BASE-T) (LAN7431 ONLY)

This section specifies the LAN7431 MII interface transmit and receive timing.

**FIGURE 7-6: MII TRANSMIT TIMING**

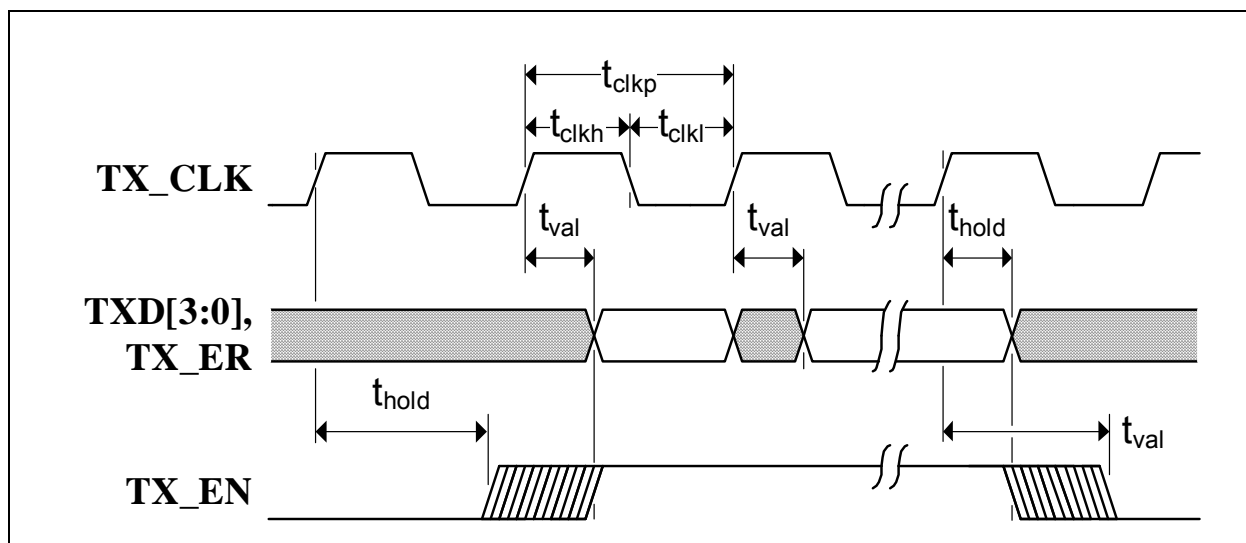

**TABLE 7-14: MII TRANSMIT TIMING VALUES**

Symbol	Description	Min	Max	Units	Notes
$t_{clkp}$	TX_CLK period	Note 7-16		ns	
$t_{clkh}$	TX_CLK high time	$t_{clkp} * 0.4$	$t_{clkp} * 0.6$	ns	
$t_{clkl}$	TX_CLK low time	$t_{clkp} * 0.4$	$t_{clkp} * 0.6$	ns	
$t_{val}$	TXD[3:0], TX_EN, TX_ER output valid from rising edge of TX_CLK		22.0	ns	Note 7-17
$t_{hold}$	TXD[3:0], TX_EN, TX_ER output hold from rising edge of TX_CLK	0		ns	Note 7-17

**Note 7-16** 40ns for 100BASE-TX operation, 400ns for 10BASE-T operation.

**Note 7-17** Timing was designed for system load between 10 pf and 25 pf.

# LAN7430/LAN7431

**FIGURE 7-7: MII RECEIVE TIMING**

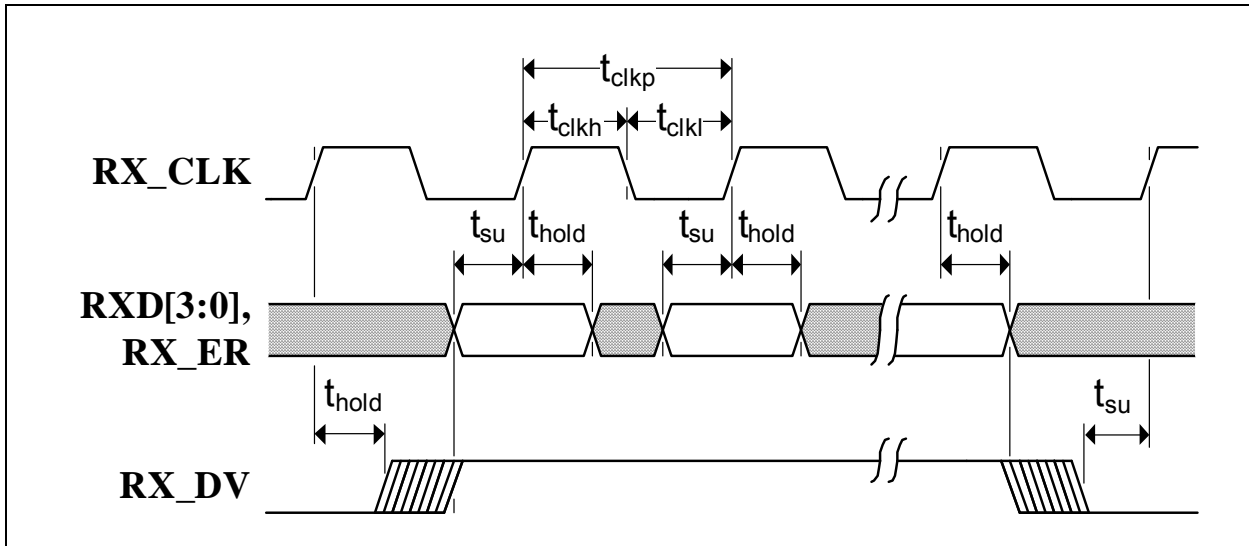

**TABLE 7-15: MII RECEIVE TIMING VALUES**

Symbol	Description	Min	Max	Units	Notes
$t_{clkp}$	RX_CLK period	Note 7-18		ns	
$t_{clkh}$	RX_CLK high time	$t_{clkp} * 0.4$	$t_{clkp} * 0.6$	ns	
$t_{clkl}$	RX_CLK low time	$t_{clkp} * 0.4$	$t_{clkp} * 0.6$	ns	
$t_{su}$	RXD[3:0], RX_DV, RX_ER setup time to rising edge of RX_CLK	8.0		ns	Note 7-19
$t_{hold}$	RXD[3:0], RX_DV, RX_ER hold time after rising edge of RX_CLK	9.0		ns	Note 7-19

**Note 7-18** 40ns for 100BASE-TX operation, 400ns for 10BASE-T operation.

**Note 7-19** Timing was designed for system load between 10 pf and 25 pf.

## 7.6.6 RGMII TIMING (LAN7431 ONLY)

This section specifies the LAN7431 RGMII interface transmit and receive timing. The RGMII interface supports the independent enabling/disabling of the **TXC** and **RXC** delays, each with unique timing properties. The RGMII timing with the **TXC/RXC** delays enabled/disabled are detailed in the following sub-sections.

**Note:** All RGMII timing specifications assume a point-to-point test circuit as defined in Figure 3 of the RGMII specification 2.0.

### 7.6.6.1 RGMII Transmit Timing (TXC Internal Delay Enabled - MAC Provides Delayed Clock)

**FIGURE 7-8: RGMII TRANSMIT TIMING (TXC INTERNAL DELAY ENABLED)**

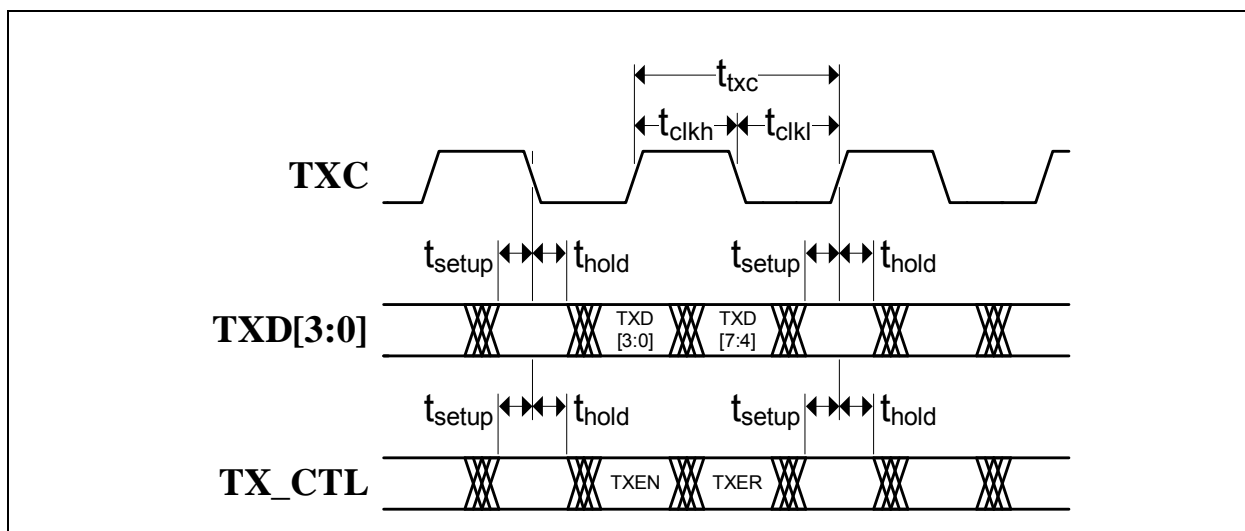

**TABLE 7-16: RGMII TRANSMIT TIMING VALUES (TXC INTERNAL DELAY ENABLED)**

Symbol	Description	Min	Typ	Max	Units
$t_{txc}$	TXC period	Note 7-20	Note 7-21	Note 7-22	ns
$t_{clkh}$	TXC high time	Note 7-23	50	Note 7-24	%
$t_{clkl}$	TXC low time	Note 7-23	50	Note 7-24	%
$t_{setup}$	TXD[3:0], TX_CTL setup time to edge of TXC (at transmitter output)	1.5			ns
$t_{hold}$	TXD[3:0], TX_CTL hold time after edge of TXC (at transmitter output)	1.5			ns

**Note 7-20** 7.2ns for 1000BASE-T operation, 36ns for 100BASE-TX operation, 360ns for 10BASE-T operation. Minimum limits are non-sustainable long term.

**Note 7-21** 8ns for 1000BASE-T operation, 40ns for 100BASE-TX operation, 400ns for 10BASE-T operation.

**Note 7-22** 8.8ns for 1000BASE-T operation, 44ns for 100BASE-TX operation, 440ns for 10BASE-T operation. Maximum limits are non-sustainable long term.

**Note 7-23** 45% for 1000BASE-T operation, 40% for 100BASE-TX or 10BASE-T operation.

**Note 7-24** 55% for 1000BASE-T operation, 60% for 100BASE-TX or 10BASE-T operation.

# LAN7430/LAN7431

## 7.6.6.2 RGMII Transmit Timing (TXC Internal Delay Disabled - PCB Provides Delayed Clock)

**FIGURE 7-9: RGMII TRANSMIT TIMING (TXC INTERNAL DELAY DISABLED)**

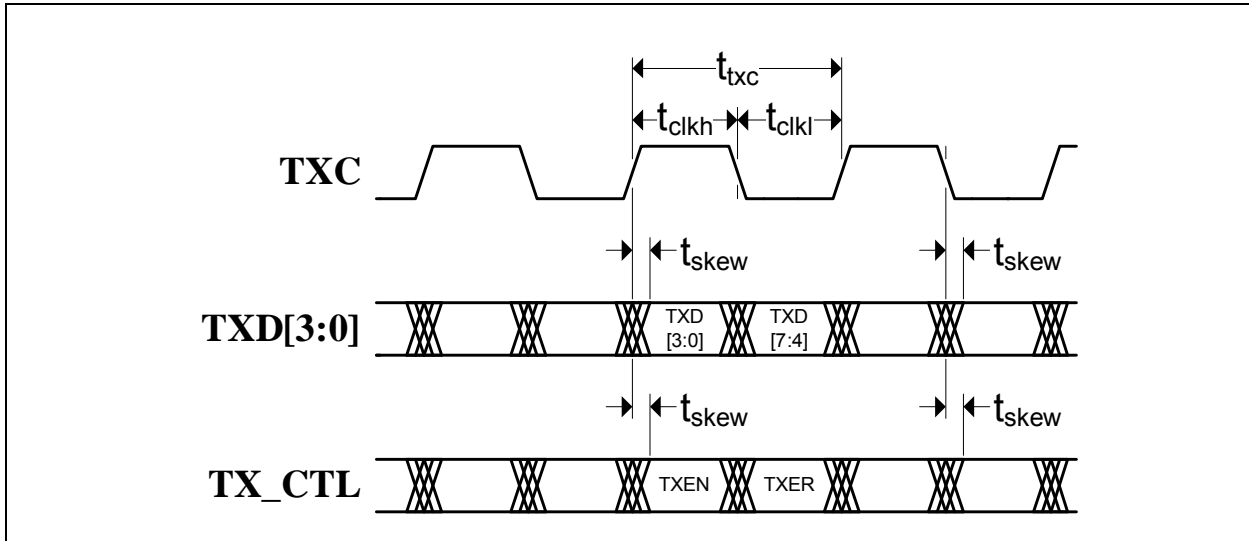

**TABLE 7-17: RGMII TRANSMIT TIMING VALUES (TXC INTERNAL DELAY DISABLED)**

Symbol	Description	Min	Typ	Max	Units
$t_{txc}$	TXC period	Note 7-25	Note 7-26	Note 7-27	ns
$t_{clkh}$	TXC high time	Note 7-28	50	Note 7-29	%
$t_{clkl}$	TXC low time	Note 7-28	50	Note 7-29	%
$t_{skew}$	Data to clock output skew (at transmitter output)	-400		400	ps

**Note 7-25** 7.2ns for 1000BASE-T operation, 36ns for 100BASE-TX operation, 360ns for 10BASE-T operation. Minimum limits are non-sustainable long term.

**Note 7-26** 8ns for 1000BASE-T operation, 40ns for 100BASE-TX operation, 400ns for 10BASE-T operation.

**Note 7-27** 8.8ns for 1000BASE-T operation, 44ns for 100BASE-TX operation, 440ns for 10BASE-T operation. Maximum limits are non-sustainable long term.

**Note 7-28** 45% for 1000BASE-T operation, 40% for 100BASE-TX or 10BASE-T operation.

**Note 7-29** 55% for 1000BASE-T operation, 60% for 100BASE-TX or 10BASE-T operation.

## 7.6.6.3 RGMII Receive Timing (RXC Internal Delay Enabled - MAC Provides Delay on Clock Input)

**FIGURE 7-10: RGMII RECEIVE TIMING (RXC INTERNAL DELAY ENABLED)**

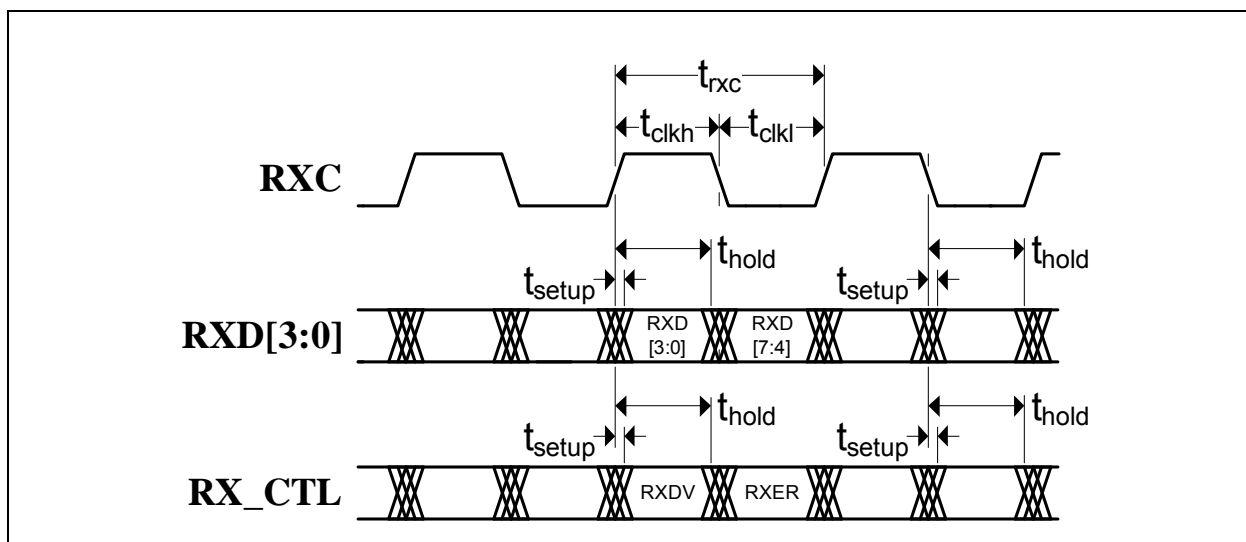

**TABLE 7-18: RGMII RECEIVE TIMING VALUES (RXC INTERNAL DELAY ENABLED)**

Symbol	Description	Min	Typ	Max	Units
$t_{rxc}$	RXC period	Note 7-30	Note 7-31	Note 7-32	ns
$t_{clkh}$	RXC high time	Note 7-33	50	Note 7-34	%
$t_{clkl}$	RXC low time	Note 7-33	50	Note 7-34	%
$t_{setup}$	RXD[3:0], RX_CTL setup time to edge of RXC	-0.9 Note 7-35			ns
$t_{hold}$	RXD[3:0], RX_CTL hold time after edge of RXC	2.7			ns

**Note 7-30** 7.2ns for 1000BASE-T operation, 36ns for 100BASE-TX operation, 360ns for 10BASE-T operation. Minimum limits are non-sustainable long term.

**Note 7-31** 8ns for 1000BASE-T operation, 40ns for 100BASE-TX operation, 400ns for 10BASE-T operation.

**Note 7-32** 8.8ns for 1000BASE-T operation, 44ns for 100BASE-TX operation, 440ns for 10BASE-T operation. Maximum limits are non-sustainable long term.

**Note 7-33** 45% for 1000BASE-T operation, 40% for 100BASE-TX or 10BASE-T operation.

**Note 7-34** 55% for 1000BASE-T operation, 60% for 100BASE-TX or 10BASE-T operation.

**Note 7-35** A negative setup means that the data can arrive after the clock.

# LAN7430/LAN7431

## 7.6.6.4 RGMII Receive Timing (RXC Internal Delay Disabled - PHY Provides Delayed Clock)

**FIGURE 7-11: RGMII RECEIVE TIMING (RXC INTERNAL DELAY DISABLED)**

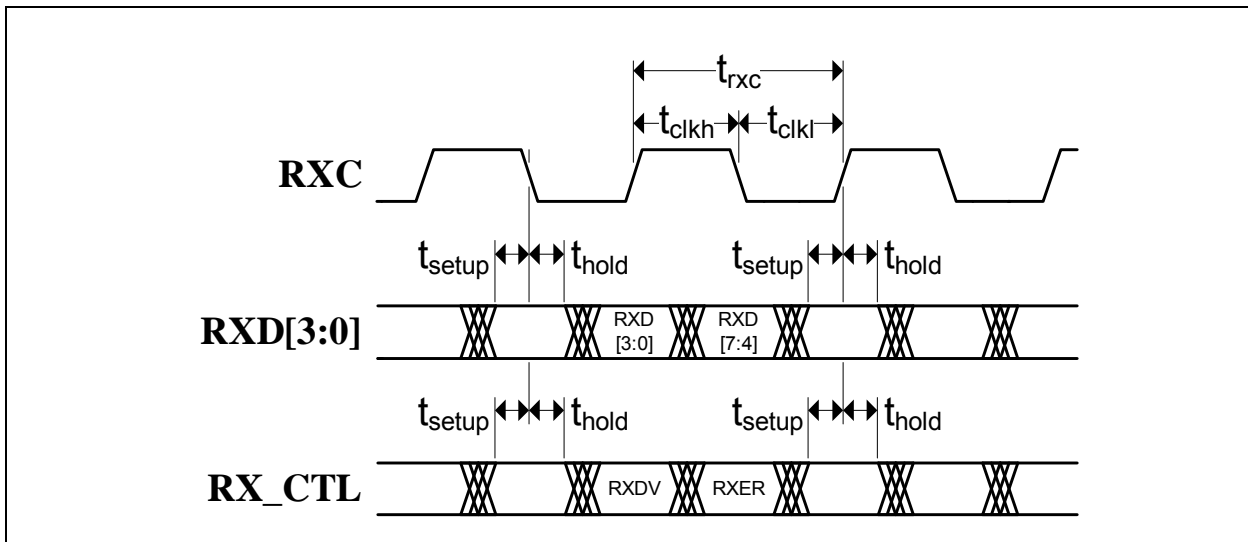

**TABLE 7-19: RGMII RECEIVE TIMING VALUES (RXC INTERNAL DELAY DISABLED)**

Symbol	Description	Min	Typ	Max	Units
$t_{rxc}$	RXC period	Note 7-36	Note 7-37	Note 7-38	ns
$t_{clkh}$	RXC high time	Note 7-39	50	Note 7-40	%
$t_{clkl}$	RXC low time	Note 7-39	50	Note 7-40	%
$t_{setup}$	RXD[3:0], RX_CTL input setup to edge of RXC	0.8			ns
$t_{hold}$	RXD[3:0], RX_CTL input hold from edge of RXC	0.8			ns

**Note 7-36** 7.2ns for 1000BASE-T operation, 36ns for 100BASE-TX operation, 360ns for 10BASE-T operation. Minimum limits are non-sustainable long term.

**Note 7-37** 8ns for 1000BASE-T operation, 40ns for 100BASE-TX operation, 400ns for 10BASE-T operation.

**Note 7-38** 8.8ns for 1000BASE-T operation, 44ns for 100BASE-TX operation, 440ns for 10BASE-T operation. Maximum limits are non-sustainable long term.

**Note 7-39** 45% for 1000BASE-T operation, 40% for 100BASE-TX or 10BASE-T operation.

**Note 7-40** 55% for 1000BASE-T operation, 60% for 100BASE-TX or 10BASE-T operation.



## 7.6.7 MDIO INTERFACE TIMING (LAN7431 ONLY)

This section specifies the LAN7431 MDIO interface timing.

**FIGURE 7-12: MDIO INTERFACE TIMING**

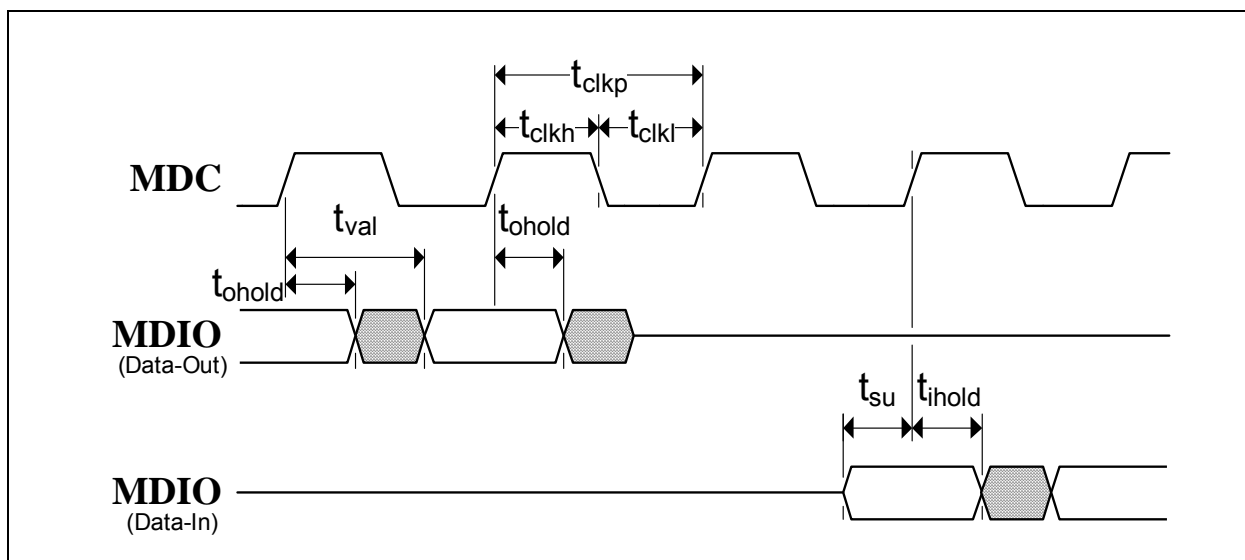

**TABLE 7-20: MDIO INTERFACE TIMING VALUES**

Symbol	Description	Min	Max	Units	Notes
$t_{clkp}$	MDC period	400		ns	<a href="#">Note 7-41</a>
$t_{clkh}$	MDC high time	180 (90%)		ns	<a href="#">Note 7-41</a>
$t_{clkl}$	MDC low time	180 (90%)		ns	<a href="#">Note 7-41</a>
$t_{val}$	MDIO (write to PHY) output valid from rising edge of MDC		250	ns	<a href="#">Note 7-42</a>
$t_{ohold}$	MDIO (write to PHY) output hold from rising edge of MDC	50		ns	<a href="#">Note 7-42</a>
$t_{su}$	MDIO (read from PHY) input setup time to rising edge of MDC	70		ns	<a href="#">Note 7-43</a>
$t_{ihold}$	MDIO (read from to PHY) input hold time after rising edge of MDC	0		ns	<a href="#">Note 7-43</a>

**Note 7-41** The MDIO Interface outputs a nominal 400 ns clock with a 50/50 duty cycle.

**Note 7-42** The MDIO Interface changes output data a nominal 120 ns following the rising edge of MDC.

**Note 7-43** The MDIO Interface samples input data a nominal 40 ns prior to the rising edge of MDC.

# LAN7430/LAN7431

## 7.6.8 JTAG TIMING

This section specifies the JTAG timing of the device.

**FIGURE 7-13: JTAG TIMING**

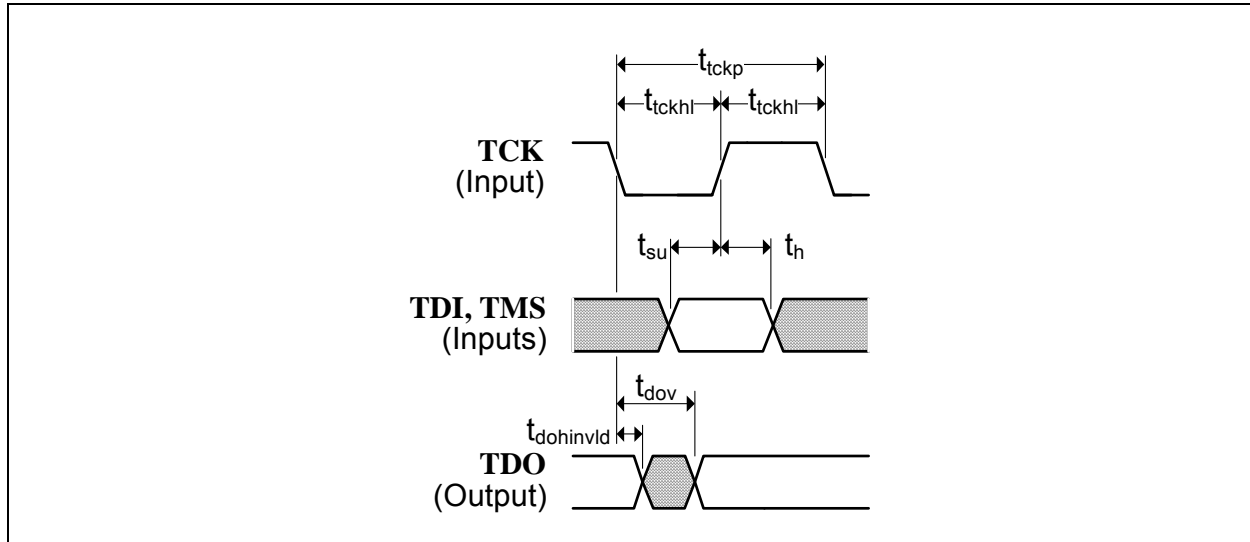

**TABLE 7-21: JTAG TIMING VALUES**

Symbol	Description	Min	Typ	Max	Units
$t_{tckp}$	TCK clock period	40			ns
$t_{tckhl}$	TCK clock high/low time	$t_{tckp} * 0.4$		$t_{tckp} * 0.6$	ns
$t_{su}$	TDI, TMS setup to TCK rising edge	10			ns
$t_h$	TDI, TMS hold from TCK rising edge	10			ns
$t_{dov}$	TDO output valid from TCK falling edge			15	ns
$t_{doinvld}$	TDO output invalid from TCK falling edge	0			ns

**Note:** JTAG timing values are with respect to an equivalent test load of 25 pF.

## 7.6.9 EEPROM TIMING

**FIGURE 7-14: EEPROM TIMING**

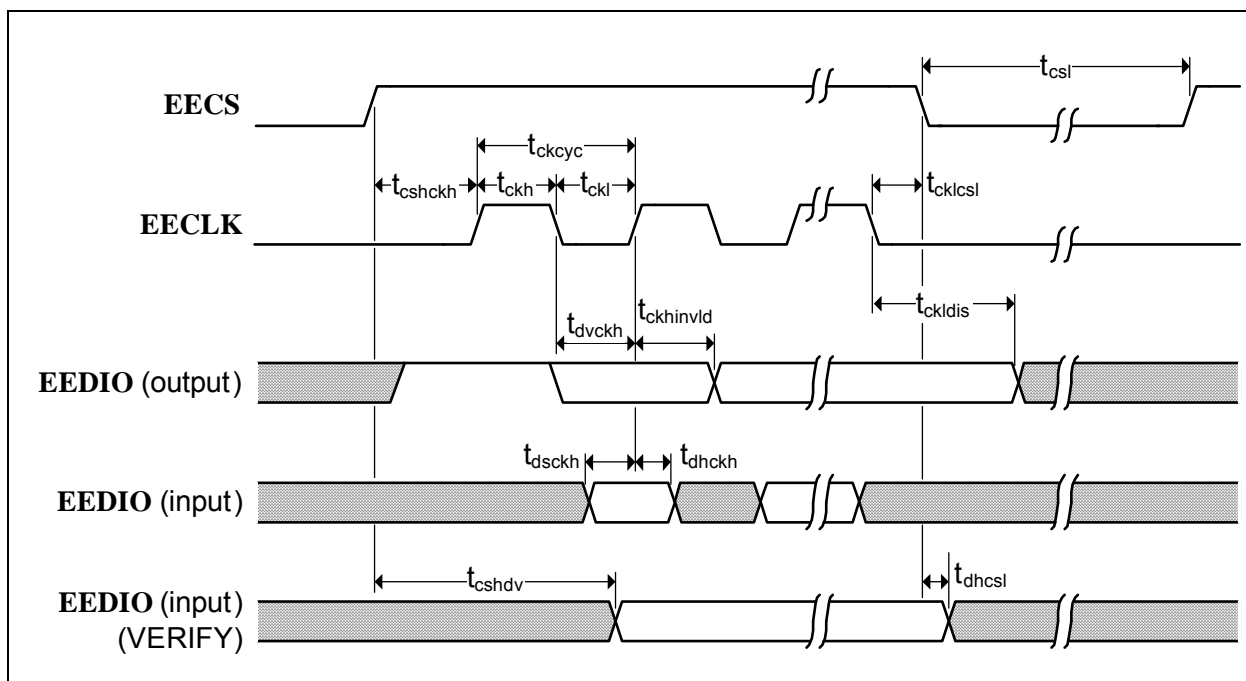

**TABLE 7-22: EEPROM TIMING VALUES**

Symbol	Description	Min	Typ	Max	Units
$t_{ckcyc}$	EECLK Cycle time	1110		1130	ns
$t_{ckh}$	EECLK High time	550		570	ns
$t_{ckl}$	EECLK Low time	550		570	ns
$t_{cshckh}$	EECS high before rising edge of EECLK	1070			ns
$t_{cklcsl}$	EECLK falling edge to EECS low	30			ns
$t_{dvckh}$	EEDIO valid before rising edge of EECLK	550			ns
$t_{ckhinvid}$	EEDIO invalid after rising edge of EECLK	550			ns
$t_{dsckh}$	EEDIO setup to rising edge of EECLK	90			ns
$t_{dhckh}$	EEDIO hold after rising edge of EECLK	0			ns
$t_{ckldis}$	EECLK low to data disable (OUTPUT)	580			ns
$t_{cshdv}$	EEDIO valid after EECS high (VERIFY)			600	ns
$t_{dhcsl}$	EEDIO hold after EECS low (VERIFY)	0			ns
$t_{csl}$	EECS low	1070			ns

# LAN7430/LAN7431

## 7.7 Clock Circuit

The device can accept either a 25MHz crystal (preferred) or a 25 MHz single-ended clock oscillator (+/- 50ppm) input. If the single-ended clock oscillator method is implemented, **XO** should be left unconnected and **XI** should be driven with a nominal 0-3.3V clock signal. The input clock duty cycle is 40% minimum, 50% typical and 60% maximum.

It is recommended that a crystal utilizing matching parallel load capacitors be used for the crystal input/output signals (**XI/XO**). See [Table 7-23](#) for the recommended crystal specifications.

**TABLE 7-23: CRYSTAL SPECIFICATIONS**

Parameter	Symbol	Min	Nom	Max	Units	Notes
Crystal Cut		AT, typ				
Crystal Oscillation Mode		Fundamental Mode				
Crystal Calibration Mode		Parallel Resonant Mode				
Frequency	$F_{fund}$	-	25.000	-	MHz	
Frequency Tolerance @ 25°C	$F_{tol}$	-	-	+/-50	PPM	<a href="#">Note 7-44</a>
Frequency Stability Over Temp	$F_{temp}$	-	-	+/-50	PPM	<a href="#">Note 7-44</a>
Frequency Deviation Over Time	$F_{age}$	-	+/-3 to 5	-	PPM	<a href="#">Note 7-45</a>
Total Allowable PPM Budget		-	-	+/-50	PPM	<a href="#">Note 7-46</a>
Shunt Capacitance	$C_O$	-	-	6	pF	
Load Capacitance	$C_L$	-	-	25	pF	
Motional Inductance	LM			10	mH	
Drive Level	$P_W$	-	-	100	uW	
Equivalent Series Resistance	$R_1$	-	-	50	Ohm	
Operating Temperature Range		<a href="#">Note 7-47</a>	-	<a href="#">Note 7-48</a>	°C	
<b>XI</b> Pin Capacitance		-	2 typ	-	pF	<a href="#">Note 7-49</a>
<b>XO</b> Pin Capacitance		-	2 typ	-	pF	<a href="#">Note 7-49</a>

**Note 7-44** The maximum allowable values for Frequency Tolerance and Frequency Stability are application dependent. Since any particular application must meet the IEEE +/-50 PPM Total PPM Budget, the combination of these two values must be approximately +/-45 PPM (allowing for aging).

**Note 7-45** Frequency Deviation Over Time is also referred to as Aging.

**Note 7-46** The total deviation for the Transmitter Clock Frequency is specified by IEEE 802.3u as +/- 50 PPM.

**Note 7-47** 0°C for commercial version, -40°C for industrial and automotive versions.

**Note 7-48** +70°C for commercial version, +85°C for industrial version, +105°C for automotive version.

**Note 7-49** This number includes the pad, the bond wire and the lead frame. PCB capacitance is not included in this value. The **XO/XI** pin and PCB capacitance values are required to accurately calculate the value of the two external load capacitors. These two external load capacitors determine the accuracy of the 25.000 MHz frequency.

## 8.0 PACKAGE INFORMATION

### 8.1 48-SQFN (LAN7430, 5.3x5.3mm Exposed Pad)

**Note:** Package offerings are under review and are subject to change. For the most current package drawings, please see the Microchip Packaging Specification located at <http://www.microchip.com/packaging>

**FIGURE 8-1: 48-SQFN PACKAGE (DRAWING)**

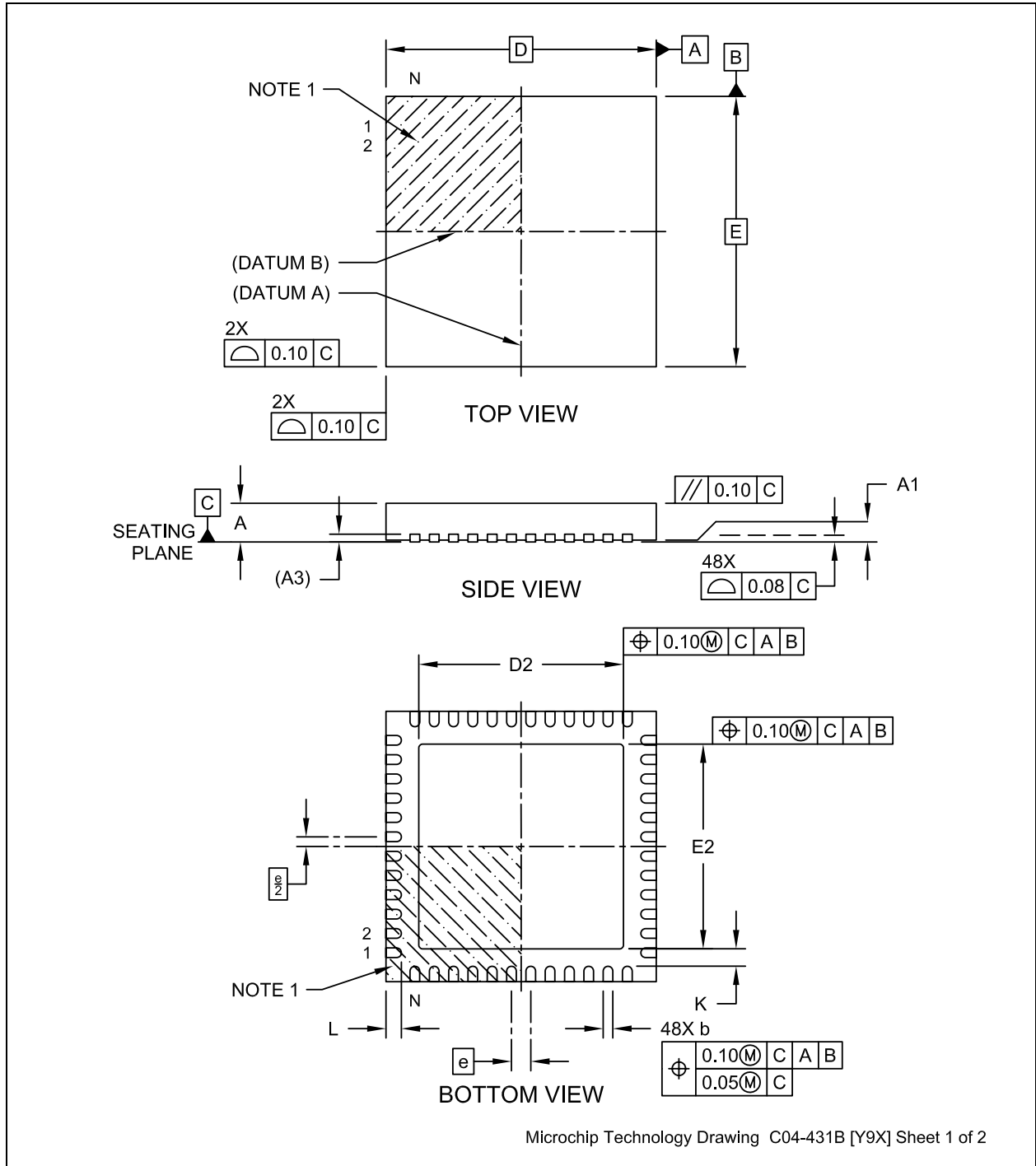

# LAN7430/LAN7431

FIGURE 8-2: 48-SQFN PACKAGE (DIMENSIONS)

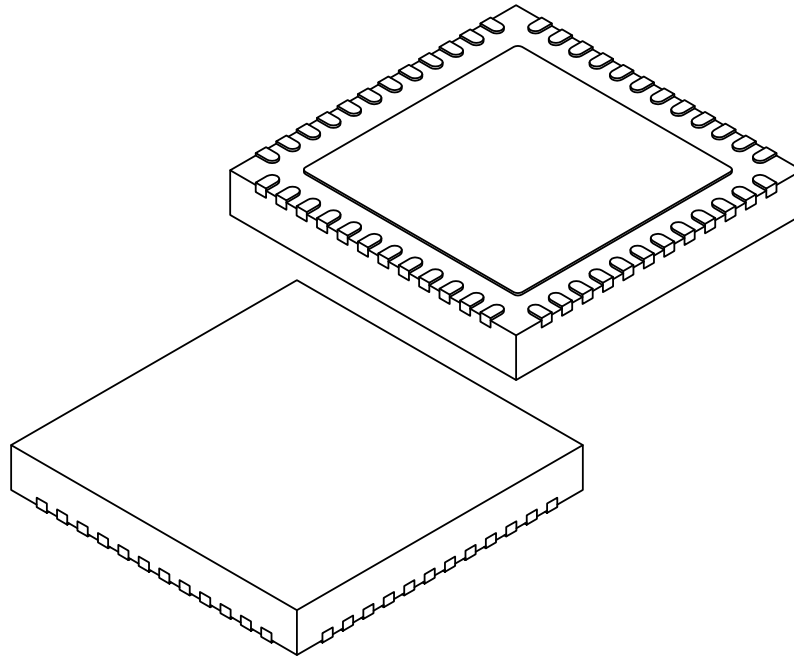

Dimension Limits	Units	MILLIMETERS		
		MIN	NOM	MAX
Number of Terminals	N	48		
Pitch	e	0.50 BSC		
Overall Height	A	0.80	0.90	1.00
Standoff	A1	0.00	0.02	0.05
Terminal Thickness	A3	0.20 REF		
Overall Length	D	7.00 BSC		
Exposed Pad Length	D2	5.20	5.30	5.40
Overall Width	E	7.00 BSC		
Exposed Pad Width	E2	5.20	5.30	5.40
Terminal Width	b	0.18	0.25	0.30
Terminal Length	L	0.30	0.40	0.50
Terminal-to-Exposed-Pad	K	0.20	-	-

Notes:

1. Pin 1 visual index feature may vary, but must be located within the hatched area.
2. Package is saw singulated
3. Dimensioning and tolerancing per ASME Y14.5M

BSC: Basic Dimension. Theoretically exact value shown without tolerances.

REF: Reference Dimension, usually without tolerance, for information purposes only.

Microchip Technology Drawing C04-431B [Y9X] Sheet 2 of 2

## 8.2 72-SQFN (LAN7431, 7.9x7.9mm Exposed Pad)

**Note:** Package offerings are under review and are subject to change. For the most current package drawings, please see the Microchip Packaging Specification located at <http://www.microchip.com/packaging>

**FIGURE 8-3: 72-SQFN PACKAGE (DRAWING)**

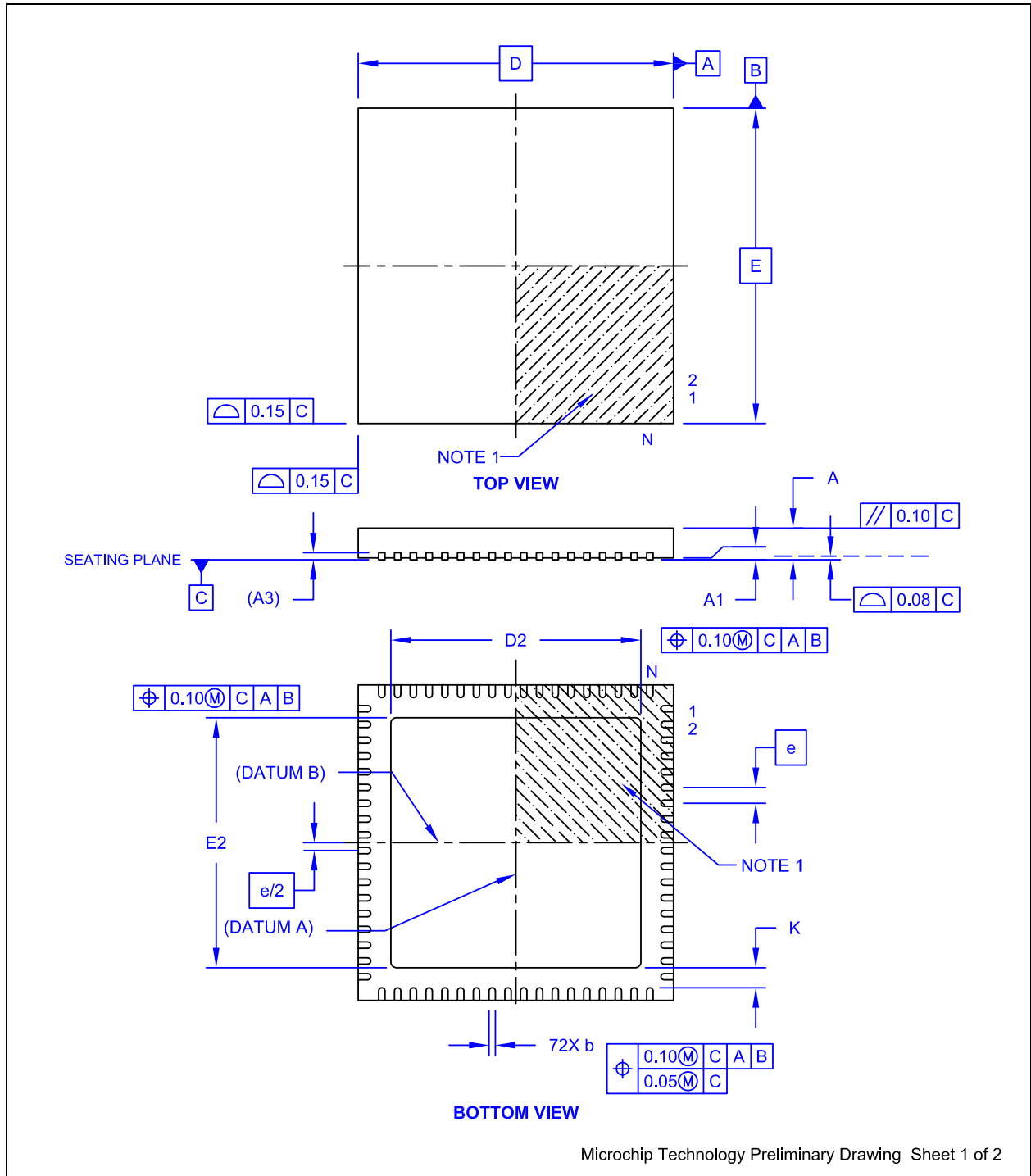

# LAN7430/LAN7431

FIGURE 8-4: 72-SQFN PACKAGE (DIMENSIONS)

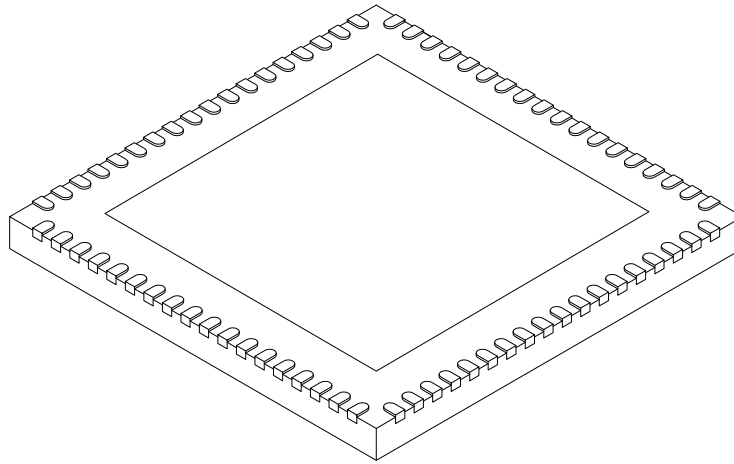

Dimension Limits	Units	MILLIMETERS		
		MIN	NOM	MAX
Number of Pins	N	72		
Pitch	e	0.50 BSC		
Overall Height	A	0.80	0.90	1.00
Standoff	A1	0.00	0.02	0.05
Contact Thickness	A3	0.20 REF		
Overall Width	E	10.00 BSC		
Exposed Pad Width	E2	7.80	7.90	8.00
Overall Length	D	10.00 BSC		
Exposed Pad Length	D2	7.80	7.90	8.00
Contact Width	b	0.18	0.25	0.30
Contact Length	L	0.30	0.40	0.50
Contact-to-Exposed Pad	K	0.60	0.65	-

**Notes:**

1. Pin 1 visual index feature may vary, but must be located within the hatched area.
2. Package is saw singulated.
3. Dimensioning and tolerancing per ASME Y14.5M.  
BSC: Basic Dimension. Theoretically exact value shown without tolerances.  
REF: Reference Dimension, usually without tolerance, for information purposes only.

Microchip Technology Preliminary Drawing Sheet 2 of 2



## APPENDIX A: DATA SHEET REVISION HISTORY

TABLE A-1: REVISION HISTORY

Revision Level & Date	Section/Figure/Entry	Correction
DS00002631D (06-25-19)	<a href="#">Section 7.4, "Power Consumption"</a>	"Preliminary" removed from tables 7-3 and 7-4.
DS00002631C (04-17-19)	<a href="#">Product Identification System</a>	Page modified to include automotive part numbers.
DS00002631B (10-24-18)	<a href="#">Section 6.1.2, "Reference Clock"</a>	Added the following: "PCIe architecture defines three clock distribution methods: common clock, data clock, and separate clock. The LAN7430/LAN7431 devices support the common clock method where both end devices, such as a host and the device, are using the same clock source. The details of the common clock method are provided in the PCIe specification."
	<a href="#">Section 3.3, "Pin Descriptions"</a>	Updated TEST pin description for clarity.
	<a href="#">Cover, Section 2.1, "General Description", Section 6.1, "PCI Express PHY (PCIe PHY)"</a>	Removed references to "IEEE 1149.6".
	<a href="#">Section 6.12.7, "Soft-Lite Reset"</a>	Added application note regarding LRST configuration reload.
	<a href="#">Table 6-3, "IEEE 1149.1 Op Codes"</a>	Removed EXTEST_PULSE and EXTEST_TRAIN entries from table.
	<a href="#">Table 7-1, "48-SQFN Package Thermal Parameters" and Table 7-2, "72-SQFN Package Thermal Parameters"</a>	Corrected $\Theta_{JC}$ velocity columns to indicate "N/A".
	<a href="#">Table 7-4, "LAN7431 Power Consumption"</a>	Corrected part number in table title.
	<a href="#">Section 6.4, "RGMII (LAN7431 Only)"</a>	Added new section.
DS00002631A (02-09-18)	All	Initial Release.

# LAN7430/LAN7431

## PRODUCT IDENTIFICATION SYSTEM

To order or obtain information, e.g., on pricing or delivery, refer to the factory or the listed sales office.

<u>PART NO.</u>	<u>[X]<sup>(1)</sup></u>	<u>X</u>	<u>/</u>	<u>XXX</u>	<u>XXX</u>
Device	Tape and Reel Option	Temperature Range		Package	Automotive Code
<b>Device:</b>	LAN7430= PCIe to GigE Controller with Ethernet PHY LAN7431= PCIe to GigE Controller with MII/RGMII				
<b>Tape and Reel Option:</b>	Blank = Standard packaging (tray) T = Tape and Reel ( <a href="#">Note 1</a> )				
<b>Temperature Range:</b>	Blank = 0°C to +70°C (Commercial) -I = -40°C to +85°C (Industrial) -V = -40°C to +105°C (Automotive)				
<b>Package:</b>	Y9X = 48-pin SQFN (LAN7430 Only) YXX = 72-pin SQFN (LAN7431 Only)				
<b>Automotive Code:</b>	Vxx = 3 character code with "V" prefix, specifying automotive product. (LAN7431 Only)				
<b>Examples:</b>					
a) LAN7430/Y9X Tray, 0°C to +70°C, 48-pin SQFN					
b) LAN7430T/Y9X Tape & reel, 0°C to +70°C, 48-pin SQFN					
c) LAN7430-I/Y9X Tray, -40°C to +85°C, 48-pin SQFN					
d) LAN7430T-I/Y9X Tape & reel, -40°C to +85°C, 48-pin SQFN					
e) LAN7431/YXX Tray, 0°C to +70°C, 72-pin SQFN					
f) LAN7431T/YXX Tape & reel, 0°C to +70°C, 72-pin SQFN					
g) LAN7431-I/YXX Tray, -40°C to +85°C, 72-pin SQFN					
h) LAN7431T-I/YXX Tape & reel, -40°C to +85°C, 72-pin SQFN					
i) LAN7431-V/YXXVAO Tray, -40°C to +105°C, 72-pin SQFN, Automotive					
j) LAN7431T-V/YXXVAO Tape & reel, -40°C to +105°C, 72-pin SQFN, Automotive					
<b>Note 1:</b> Tape and Reel identifier only appears in the catalog part number description. This identifier is used for ordering purposes and is not printed on the device package. Check with your Microchip Sales Office for package availability with the Tape and Reel option.					

## THE MICROCHIP WEB SITE

Microchip provides online support via our WWW site at [www.microchip.com](http://www.microchip.com). This web site is used as a means to make files and information easily available to customers. Accessible by using your favorite Internet browser, the web site contains the following information:

- **Product Support** – Data sheets and errata, application notes and sample programs, design resources, user's guides and hardware support documents, latest software releases and archived software
- **General Technical Support** – Frequently Asked Questions (FAQ), technical support requests, online discussion groups, Microchip consultant program member listing
- **Business of Microchip** – Product selector and ordering guides, latest Microchip press releases, listing of seminars and events, listings of Microchip sales offices, distributors and factory representatives

## CUSTOMER CHANGE NOTIFICATION SERVICE

Microchip's customer notification service helps keep customers current on Microchip products. Subscribers will receive e-mail notification whenever there are changes, updates, revisions or errata related to a specified product family or development tool of interest.

To register, access the Microchip web site at [www.microchip.com](http://www.microchip.com). Under "Support", click on "Customer Change Notification" and follow the registration instructions.

## CUSTOMER SUPPORT

Users of Microchip products can receive assistance through several channels:

- Distributor or Representative
- Local Sales Office
- Field Application Engineer (FAE)
- Technical Support

Customers should contact their distributor, representative or field application engineer (FAE) for support. Local sales offices are also available to help customers. A listing of sales offices and locations is included in the back of this document.

**Technical support is available through the web site at: <http://microchip.com/support>**

# LAN7430/LAN7431

---

## Note the following details of the code protection feature on Microchip devices:

- Microchip products meet the specification contained in their particular Microchip Data Sheet.
- Microchip believes that its family of products is one of the most secure families of its kind on the market today, when used in the intended manner and under normal conditions.
- There are dishonest and possibly illegal methods used to breach the code protection feature. All of these methods, to our knowledge, require using the Microchip products in a manner outside the operating specifications contained in Microchip's Data Sheets. Most likely, the person doing so is engaged in theft of intellectual property.
- Microchip is willing to work with the customer who is concerned about the integrity of their code.
- Neither Microchip nor any other semiconductor manufacturer can guarantee the security of their code. Code protection does not mean that we are guaranteeing the product as “unbreakable.”

Code protection is constantly evolving. We at Microchip are committed to continuously improving the code protection features of our products. Attempts to break Microchip's code protection feature may be a violation of the Digital Millennium Copyright Act. If such acts allow unauthorized access to your software or other copyrighted work, you may have a right to sue for relief under that Act.

---

Information contained in this publication regarding device applications and the like is provided only for your convenience and may be superseded by updates. It is your responsibility to ensure that your application meets with your specifications. MICROCHIP MAKES NO REPRESENTATIONS OR WARRANTIES OF ANY KIND WHETHER EXPRESS OR IMPLIED, WRITTEN OR ORAL, STATUTORY OR OTHERWISE, RELATED TO THE INFORMATION, INCLUDING BUT NOT LIMITED TO ITS CONDITION, QUALITY, PERFORMANCE, MERCHANTABILITY OR FITNESS FOR PURPOSE. Microchip disclaims all liability arising from this information and its use. Use of Microchip devices in life support and/or safety applications is entirely at the buyer's risk, and the buyer agrees to defend, indemnify and hold harmless Microchip from any and all damages, claims, suits, or expenses resulting from such use. No licenses are conveyed, implicitly or otherwise, under any Microchip intellectual property rights unless otherwise stated.

## Trademarks

The Microchip name and logo, the Microchip logo, Adaptec, AnyRate, AVR, AVR logo, AVR Freaks, BesTime, BitCloud, chipKIT, chipKIT logo, CryptoMemory, CryptoRF, dsPIC, FlashFlex, flexPWR, HELDO, IGLOO, JukeBlox, KeeLoq, Klear, LANCheck, LinkMD, maXStylus, maXTouch, MediaLB, megaAVR, Microsemi, Microsemi logo, MOST, MOST logo, MPLAB, OptoLyzer, PackeTime, PIC, picoPower, PICSTART, PIC32 logo, PolarFire, Prochip Designer, QTouch, SAM-BA, SenGenuity, SpyNIC, SST, SST Logo, SuperFlash, Symmetricom, SyncServer, Tachyon, TempTracker, TimeSource, tinyAVR, UNI/O, Vectron, and XMEGA are registered trademarks of Microchip Technology Incorporated in the U.S.A. and other countries.

APT, ClockWorks, The Embedded Control Solutions Company, EtherSynch, FlashTec, Hyper Speed Control, HyperLight Load, IntelliMOS, Libero, motorBench, mTouch, Powermite 3, Precision Edge, ProASIC, ProASIC Plus, ProASIC Plus logo, Quiet-Wire, SmartFusion, SyncWorld, Temux, TimeCesium, TimeHub, TimePictra, TimeProvider, Vite, WinPath, and ZL are registered trademarks of Microchip Technology Incorporated in the U.S.A.

Adjacent Key Suppression, AKS, Analog-for-the-Digital Age, Any Capacitor, AnyIn, AnyOut, BlueSky, BodyCom, CodeGuard, CryptoAuthentication, CryptoAutomotive, CryptoCompanion, CryptoController, dsPICDEM, dsPICDEM.net, Dynamic Average Matching, DAM, ECAN, EtherGREEN, In-Circuit Serial Programming, ICSP, INICnet, Inter-Chip Connectivity, JitterBlocker, KlearNet, KlearNet logo, memBrain, Mindi, MiWi, MPASM, MPF, MPLAB Certified logo, MPLIB, MPLINK, MultiTRAK, NetDetach, Omniscient Code Generation, PICDEM, PICDEM.net, PICkit, PICtail, PowerSmart, PureSilicon, QMatrix, REAL ICE, Ripple Blocker, SAM-ICE, Serial Quad I/O, SMART-I.S., SQR, SuperSwitcher, SuperSwitcher II, Total Endurance, TSHARC, USBCheck, VariSense, ViewSpan, WiperLock, Wireless DNA, and ZENA are trademarks of Microchip Technology Incorporated in the U.S.A. and other countries.

SQTP is a service mark of Microchip Technology Incorporated in the U.S.A.

The Adaptec logo, Frequency on Demand, Silicon Storage Technology, and Symmcom are registered trademarks of Microchip Technology Inc. in other countries.

GestIC is a registered trademark of Microchip Technology Germany II GmbH & Co. KG, a subsidiary of Microchip Technology Inc., in other countries.

All other trademarks mentioned herein are property of their respective companies.

© 2018-2019, Microchip Technology Incorporated, All Rights Reserved.

ISBN:

*For information regarding Microchip's Quality Management Systems, please visit [www.microchip.com/quality](http://www.microchip.com/quality).*



## Worldwide Sales and Service

### AMERICAS

**Corporate Office**  
2355 West Chandler Blvd.  
Chandler, AZ 85224-6199  
Tel: 480-792-7200  
Fax: 480-792-7277  
Technical Support:  
<http://www.microchip.com/support>  
Web Address:  
[www.microchip.com](http://www.microchip.com)

**Atlanta**  
Duluth, GA  
Tel: 678-957-9614  
Fax: 678-957-1455

**Austin, TX**  
Tel: 512-257-3370

**Boston**  
Westborough, MA  
Tel: 774-760-0087  
Fax: 774-760-0088

**Chicago**  
Itasca, IL  
Tel: 630-285-0071  
Fax: 630-285-0075

**Dallas**  
Addison, TX  
Tel: 972-818-7423  
Fax: 972-818-2924

**Detroit**  
Novi, MI  
Tel: 248-848-4000

**Houston, TX**  
Tel: 281-894-5983

**Indianapolis**  
Noblesville, IN  
Tel: 317-773-8323  
Fax: 317-773-5453  
Tel: 317-536-2380

**Los Angeles**  
Mission Viejo, CA  
Tel: 949-462-9523  
Fax: 949-462-9608  
Tel: 951-273-7800

**Raleigh, NC**  
Tel: 919-844-7510

**New York, NY**  
Tel: 631-435-6000

**San Jose, CA**  
Tel: 408-735-9110  
Tel: 408-436-4270

**Canada - Toronto**  
Tel: 905-695-1980  
Fax: 905-695-2078

### ASIA/PACIFIC

**Australia - Sydney**  
Tel: 61-2-9868-6733

**China - Beijing**  
Tel: 86-10-8569-7000

**China - Chengdu**  
Tel: 86-28-8665-5511

**China - Chongqing**  
Tel: 86-23-8980-9588

**China - Dongguan**  
Tel: 86-769-8702-9880

**China - Guangzhou**  
Tel: 86-20-8755-8029

**China - Hangzhou**  
Tel: 86-571-8792-8115

**China - Hong Kong SAR**  
Tel: 852-2943-5100

**China - Nanjing**  
Tel: 86-25-8473-2460

**China - Qingdao**  
Tel: 86-532-8502-7355

**China - Shanghai**  
Tel: 86-21-3326-8000

**China - Shenyang**  
Tel: 86-24-2334-2829

**China - Shenzhen**  
Tel: 86-755-8864-2200

**China - Suzhou**  
Tel: 86-186-6233-1526

**China - Wuhan**  
Tel: 86-27-5980-5300

**China - Xian**  
Tel: 86-29-8833-7252

**China - Xiamen**  
Tel: 86-592-2388138

**China - Zhuhai**  
Tel: 86-756-3210040

### ASIA/PACIFIC

**India - Bangalore**  
Tel: 91-80-3090-4444

**India - New Delhi**  
Tel: 91-11-4160-8631

**India - Pune**  
Tel: 91-20-4121-0141

**Japan - Osaka**  
Tel: 81-6-6152-7160

**Japan - Tokyo**  
Tel: 81-3-6880-3770

**Korea - Daegu**  
Tel: 82-53-744-4301

**Korea - Seoul**  
Tel: 82-2-554-7200

**Malaysia - Kuala Lumpur**  
Tel: 60-3-7651-7906

**Malaysia - Penang**  
Tel: 60-4-227-8870

**Philippines - Manila**  
Tel: 63-2-634-9065

**Singapore**  
Tel: 65-6334-8870

**Taiwan - Hsin Chu**  
Tel: 886-3-577-8366

**Taiwan - Kaohsiung**  
Tel: 886-7-213-7830

**Taiwan - Taipei**  
Tel: 886-2-2508-8600

**Thailand - Bangkok**  
Tel: 66-2-694-1351

**Vietnam - Ho Chi Minh**  
Tel: 84-28-5448-2100

### EUROPE

**Austria - Wels**  
Tel: 43-7242-2244-39  
Fax: 43-7242-2244-393

**Denmark - Copenhagen**  
Tel: 45-4450-2828  
Fax: 45-4485-2829

**Finland - Espoo**  
Tel: 358-9-4520-820

**France - Paris**  
Tel: 33-1-69-53-63-20  
Fax: 33-1-69-30-90-79

**Germany - Garching**  
Tel: 49-8931-9700

**Germany - Haan**  
Tel: 49-2129-3766400

**Germany - Heilbronn**  
Tel: 49-7131-72400

**Germany - Karlsruhe**  
Tel: 49-721-625370

**Germany - Munich**  
Tel: 49-89-627-144-0  
Fax: 49-89-627-144-44

**Germany - Rosenheim**  
Tel: 49-8031-354-560

**Israel - Ra'anana**  
Tel: 972-9-744-7705

**Italy - Milan**  
Tel: 39-0331-742611  
Fax: 39-0331-466781

**Italy - Padova**  
Tel: 39-049-7625286

**Netherlands - Drunen**  
Tel: 31-416-690399  
Fax: 31-416-690340

**Norway - Trondheim**  
Tel: 47-7288-4388

**Poland - Warsaw**  
Tel: 48-22-3325737

**Romania - Bucharest**  
Tel: 40-21-407-87-50

**Spain - Madrid**  
Tel: 34-91-708-08-90  
Fax: 34-91-708-08-91

**Sweden - Gothenberg**  
Tel: 46-31-704-60-40

**Sweden - Stockholm**  
Tel: 46-8-5090-4654

**UK - Wokingham**  
Tel: 44-118-921-5800  
Fax: 44-118-921-5820