

L99SD01

Integrated solenoid driver for CNG electronic injection systems



Automotive-qualified device for accurate and efficient control of Compressed Natural Gas (CNG) injection systems

The L99SD01 represents the state of the art in CNG electronic injection systems. Thanks to its high level of integration, all the circuits needed to reliably and accurately drive the injector coil are integrated into the same device. The embedded closed-loop current regulator gives a high level of precision in CNG injection previously not reachable, resulting in an augmented reliability and a much easier compliancy with stringent CO₂ emissions standards such as Euro 6.

KEY FEATURES

- Power MOS, protections, diagnostic and I²C interface circuits in a single device
- Closed-loop current control of solenoid current
- Programmable injector current profile (timing and current amplitude)

KEY BENEFITS

- Improved system reliability and enhanced diagnostics
- Intrinsic compensation of CNG injection over ageing effects, battery voltage, temperature drifts and injector production spreads
- Higher system efficiency
- Easier compliancy with more stringent CO₂ emissions standards

KEY APPLICATIONS

- Compressed Natural Gas (CNG) electronic injection systems

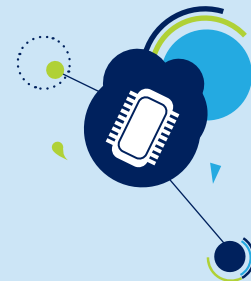

L99SD01: STATE OF THE ART FOR CNG ELECTRONIC INJECTION SYSTEMS

In addition to guaranteeing fuel injection integrity in any condition of battery voltage, system age, temperature and kind of injector, the latest standards on CO₂ emissions (e.g. Euro 6) raise the bar of the performances required for electronic injection systems in terms of precision in the control of both the current flowing in the injector coil and the dwelling-time.

Moreover, the automotive requirements for higher reliability and better diagnostics, complement the design challenge making it even more difficult.

Thanks to ST's system-in-package approach, which integrates the required power MOSFETs as well as the control and the diagnostic circuitries in a single device, the L99SD01 naturally provides higher reliability and system protection.

Additionally, the integrated closed-loop control of the injector coil allows reaching the minimum current required to ensure the proper injector coil behavior at any battery voltage, temperature, injector production spread and age.

The L99SD01 can be used without any re-programming if the default values of the internal registers match the target application. On the contrary, if it's required to customize the current control loop and its related timings, the dedicated I²C interface can be used to properly configure the device.

The L99SD01 represents the state of the art in CNG electronic injection systems: more reliable, more efficient, and more compact.

L99SD01 APPLICATION AND DEVICE BLOCK DIAGRAM

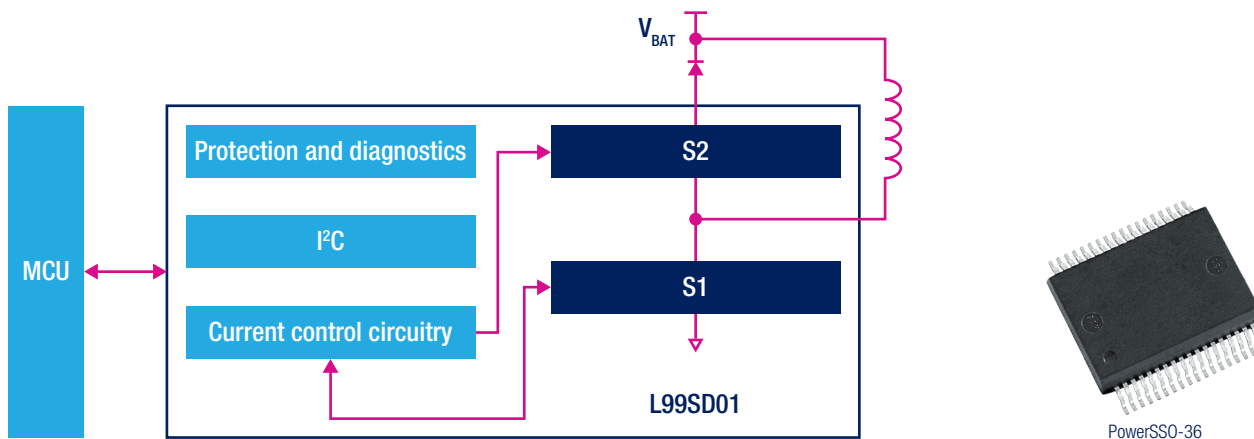

Part number	S1 and S2 R _{DS(on)}	Maximum load current	Coil current profile and timings	Switching operations
L99SD01-E	60 mΩ (maximum @ 25 °C)	14 A	Fully programmable	Above 10 kHz

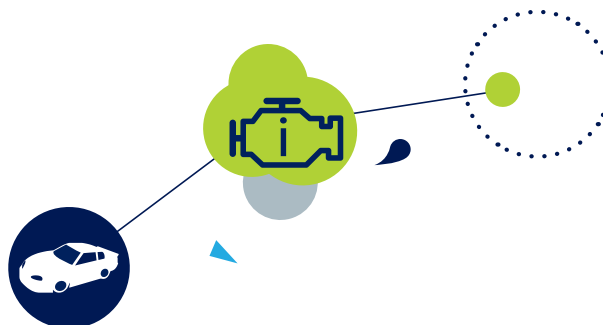

© STMicroelectronics - January 2015 - Printed in United Kingdom - All rights reserved
The STMicroelectronics corporate logo is a registered trademark of the STMicroelectronics group of companies
All other names are the property of their respective owners

