

HIGH SIDE DRIVER

ADVANCE DATA

- OPERATING SUPPLY VOLTAGE UP TO 25V
- DC CURRENT 0.3A
- $R_{ON} < 800m\Omega$
- DIAGNOSTIC AND PROTECTION FUNCTIONS
- μP COMPATIBLE
- ENABLE INPUT FOR STAND-BY MODE

DESCRIPTION

The L9820 High Side Driver realized with Multipower - BCD mixed technology, drives resistive or inductive loads with one side connected to ground.

The ENABLE input is TTL compatible and a diagnostic output provides an indication of short circuit and device status (thermal and overvoltage shut-down). Onchip thermal protection and short circuit protection are provided.

MULTIPOWER BCD TECHNOLOGY

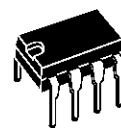

Minidip

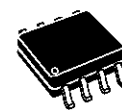

SO8

ORDERING NUMBERS:

L9820

L9820D

BLOCK DIAGRAM

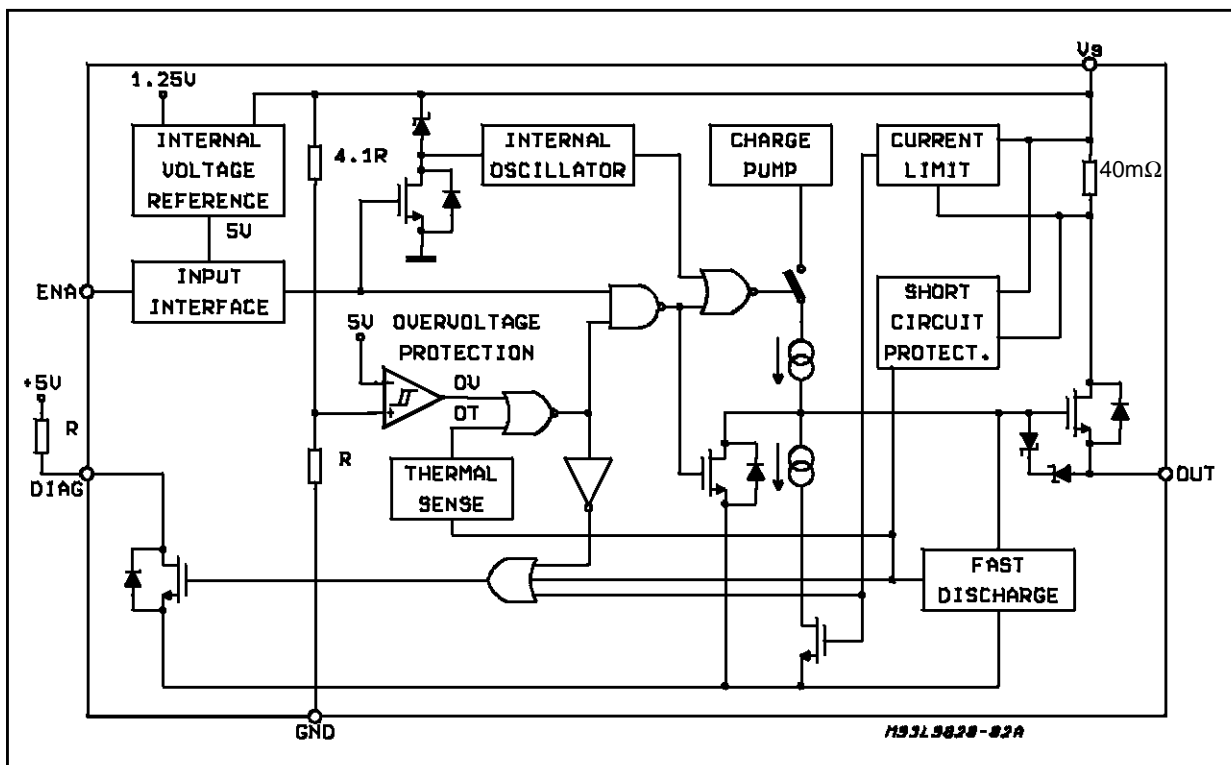

ABSOLUTE MAXIMUM RATINGS

Symbol	Parameter	Value	Unit
V_S	Max Forward Voltage	50	Vdc
I_R	Reverse Bias Current at -1.3V	-0.46	A
V_5	Input Voltage (to GND)	-0.3 to 20	V
V_8	Diag. Output Voltage (to GND)	-0.3 to 20	V
V_1	Output Voltage (to GND)	-0.3 to 25	V
I_4	Supply Current	Internally limited	
I_5	Enable Input Current	0.5	mA
I_8	Diag. Out Current (sink)	10	mA
I_1	Output Current	Internally limited	
T_{op}	Operation Temperature	-40 to 85	°C
T_j, T_{stg}	Junction and Storage Temperature Range	-55 to 150	°C
T_{jp}	Detecting Temperature	150	°C

PIN CONNECTION (Top views)

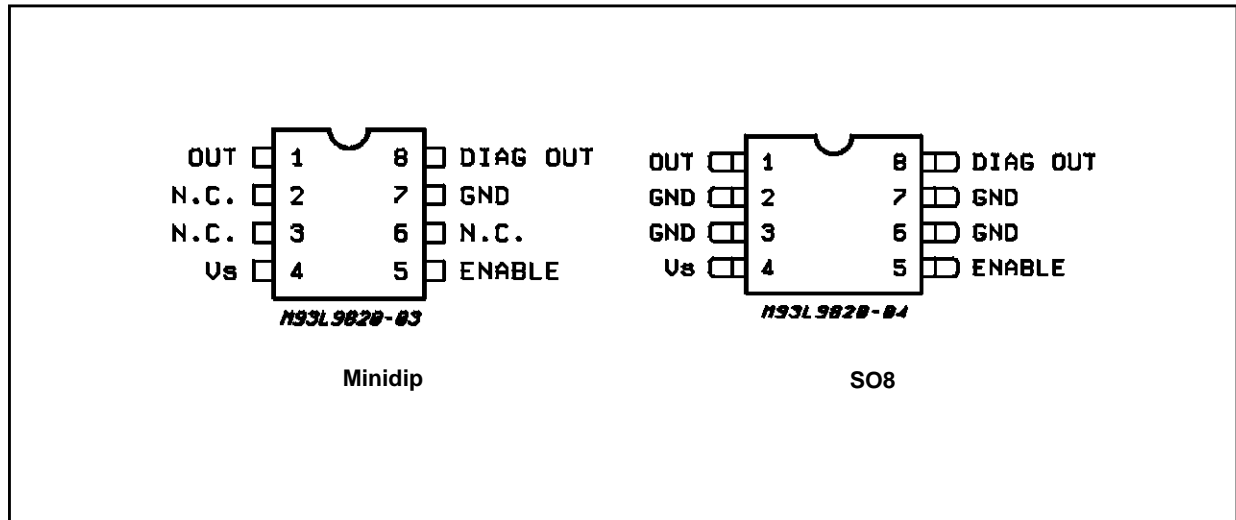

THERMAL DATA

Symbol	Parameter	Max.	Minidip	SO8	Unit
$R_{th\ j-amb}$	Thermal Resistance Junction-ambient		100	200	°C/W

TRUTH TABLE

H: high level
L: low level

ENABLE	FUNCTION	DIAG. STATUS	POWER STATUS
L	Operating OFF	H	L
H	Normal Operation	H	H
H	Overvoltage Protection ON	L	L
H	Overcurrent Protection ON	L	L
H	Overtemperature Protection ON	L	L

PIN FUNCTIONS

N.	Name	Description
1	POWER OUTPUT	The device is provided with short circuit protection.
4	POWER SUPPLY	Supply voltage input.
5	ENABLE INPUT	TTL compatible input. High level on this pin means output current ON. The low level voltage switches off the charge pump, the power stage and the diagnostic output reducing to the minimum value the quiescent current.
7	GROUND	This pin must be connected to ground.
8	DIAGNOSTIC FEEDBACK	The diagnostic circuit is active in input high level condition. This output detects with Typically 50µs delay at T _{amb} = 25°C the following faults: – Overvoltage condition. – Thermal shutdown. – Short circuit. The power stage current is internally limited at 1.5A. The diagnostic output is active low. The diagnostic delay time allows to avoid spurious diagnosis(i.e.: turn ON overcurrent, overvoltage spikes etc.).

ELECTRICAL CHARACTERISTICS (V_S = 14.4V, -40°C ≤ T_j ≤ +85°C, unless otherwise specified.)

Symbol	Parameter	Test Condition	Min.	Typ.	Max.	Unit
V _S	Operating Supply Voltage		6		25	V
R _{on}	On Resistance	Input > 2V, T _j = 25°C Input > 2V, Full T range		0.6	0.8 1.2	Ω Ω
I _{off}	Off State Supply Current	T _j < 35°C T _j = 85°C			130 300	µA µA
I _{on}	On State Supply Current				4	mA
V _{EL}	Enable Low Level				0.8	V
V _{EH}	Enable High Level		2			V
I _E	Enable Current	0V < V _i < 5V			10	µA
I _{leakd}	Diagnostic Output Leakage Current	V _{CC} = 5V Diagnostic Output High			10	µA
V _{satd}	Diagnostic Output Saturated Voltage	I _{sink} < 3.5mA			0.4	V
t _{dd}	Diagnostic Delay Time	T _j = 25°C		30		µs
t _{don}	Output ON Delay Time	T _j = 25°C		30		µs
t _r	Output ON Rise Time	T _j = 25°C		100		µs
t _{doff}	Output OFF Delay Time	T _j = 25°C		80		µs
t _f	Output OFF Fall Time	T _j = 25°C		100		µs
V _{don}	Overvoltage Detection ON		25			V
V _{dh}	Overvoltage Hysteresis		2		5	V
I _{don}	Overcurrent Detection ON		0.5		1.5	A
T _{don}	Overtemperature Detection ON		150			°C
T _{dh}	Overtemperature Hysteresis			25	50	°C

SO8 PACKAGE MECHANICAL DATA

DIM.	mm			inch		
	MIN	TYP	MAX	MIN	TYP	MAX
A			1.75			0.069
a1	0.1		0.25	0.004		0.010
a2			1.65			0.065
a3	0.65		0.85	0.026		0.033
b	0.35		0.48	0.014		0.019
b1	0.19		0.25	0.007		0.010
C	0.25		0.5	0.010		0.020
c1		45			1.772	
D		1	4.8		0.039	0.189
E	5.8		6.2	0.228		0.244
e		1.27			0.050	
e3		3.81			0.150	
F		1	3.8		0.039	0.150
G						
L	0.4		1.27	0.016		0.050
M			0.6			0.024
S			8			0.315

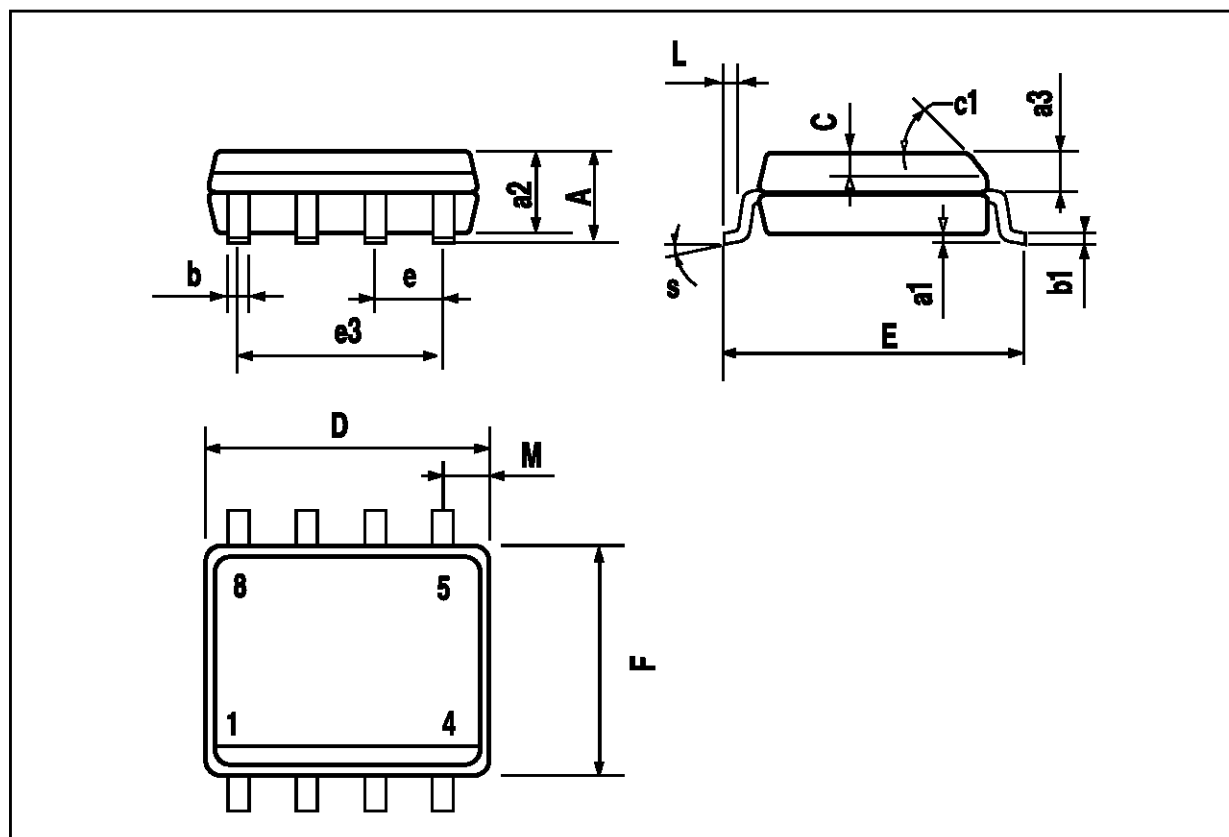

MINIDIP PACKAGE MECHANICAL DATA

DIM.	mm			inch		
	MIN.	TYP.	MAX.	MIN.	TYP.	MAX.
A		3.32			0.131	
a1	0.51			0.020		
B	1.15		1.65	0.045		0.065
b	0.356		0.55	0.014		0.022
b1	0.204		0.304	0.008		0.012
D			10.92			0.430
E	7.95		9.75	0.313		0.384
e		2.54			0.100	
e3		7.62			0.300	
e4		7.62			0.300	
F			6.6			0.260
I			5.08			0.200
L	3.18		3.81	0.125		0.150
Z			1.52			0.060

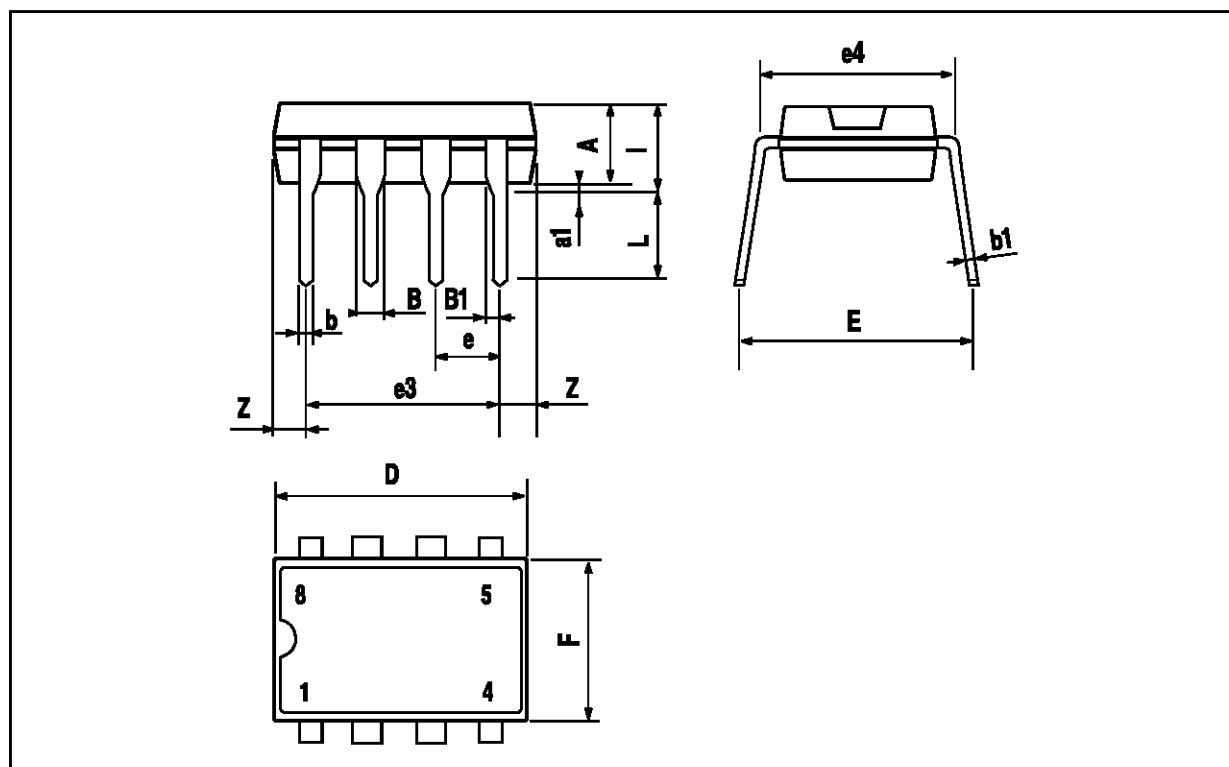

Information furnished is believed to be accurate and reliable. However, SGS-THOMSON Microelectronics assumes no responsibility for the consequences of use of such information nor for any infringement of patents or other rights of third parties which may result from its use. No license is granted by implication or otherwise under any patent or patent rights of SGS-THOMSON Microelectronics. Specification mentioned in this publication are subject to change without notice. This publication supersedes and replaces all information previously supplied. SGS-THOMSON Microelectronics products are not authorized for use as critical components in life support devices or systems without express written approval of SGS-THOMSON Microelectronics.

© 1996 SGS-THOMSON Microelectronics – Printed in Italy – All Rights Reserved
SGS-THOMSON Microelectronics GROUP OF COMPANIES

Australia - Brazil - Canada - China - France - Germany - Hong Kong - Italy - Japan - Korea - Malaysia - Malta - Morocco - The Netherlands - Singapore - Spain - Sweden - Switzerland - Taiwan - Thailand - United Kingdom - U.S.A.