

SMART QUAD SWITCH

- Modified VDMOS Power Stage ($U_{DSBR} > 80V$)
- $R_{DS(on)} < 500\text{ m}\Omega$ ($T_j = 25^\circ\text{C}$)
- CMOS Compatible Inputs
- Enable Input (Reset)
- Outputs Capable of up to 2.2 Amperes
- Outputs Internally Clamped at 70V for Fast Inductive Load Switch Off
- Wide operating supply voltage from 4.7V up to 30V

DIAGNOSTIC FUNCTIONS

- Open Load Detection (Output off, 100 μs -filtering time)
- Short to Ground Detection (Output off, 100 μs -filtering time)
- Short to Battery Detection (Output on)
- Over temperature detection (Output on)
- Storage of last fault in 8 Bit - Serial Register
- Fault Signal Indication at Serial Data Out without need to read out the Serial Interface
- Daisy Chainable Serial Diagnostic

BLOCK DIAGRAM

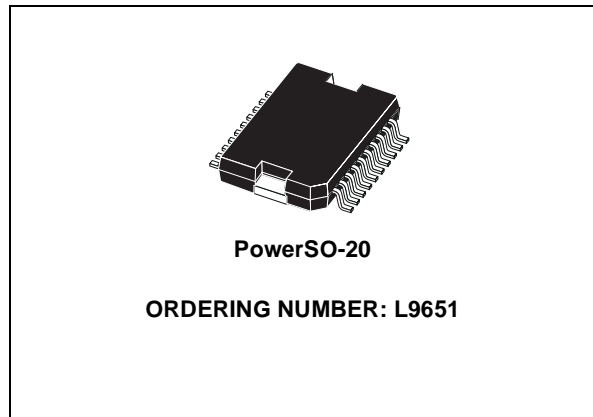
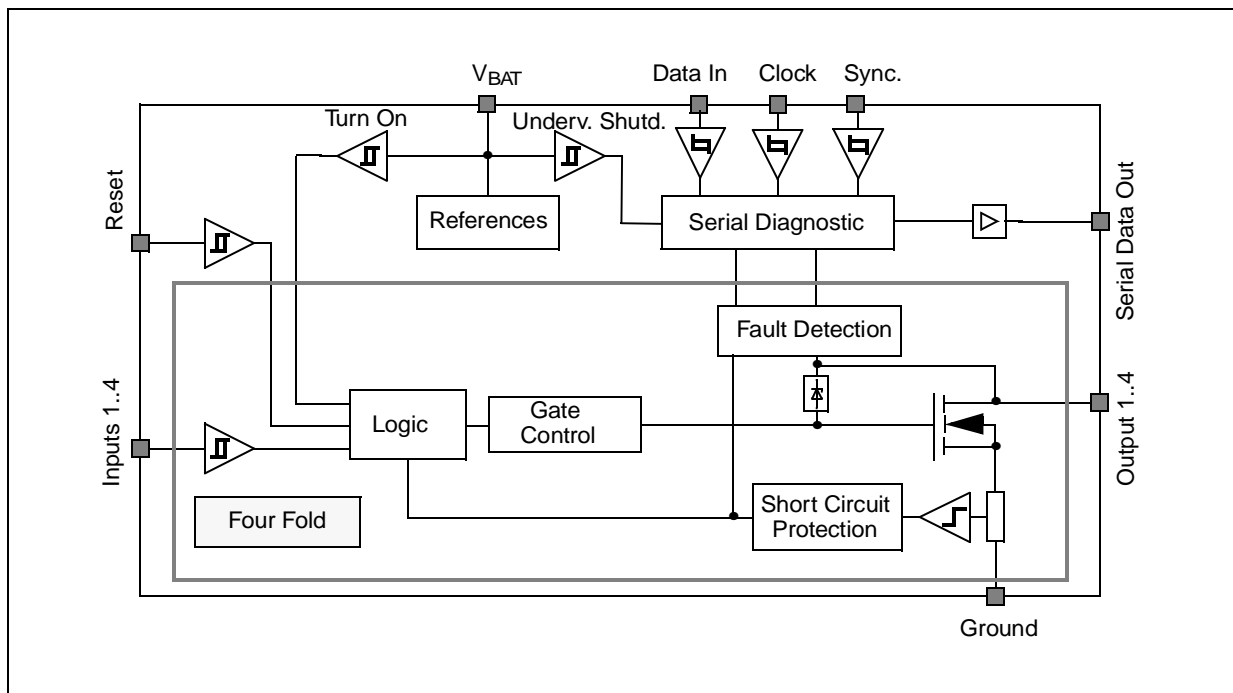

- Serial Interface Clock Frequency up to 500kHz

DESCRIPTION

The L9651 consists of four identical low side power switches. A serial diagnostic interface indicates failure mode of each switch (short circuit to V_{BAT} or ground and open load or over temperature).

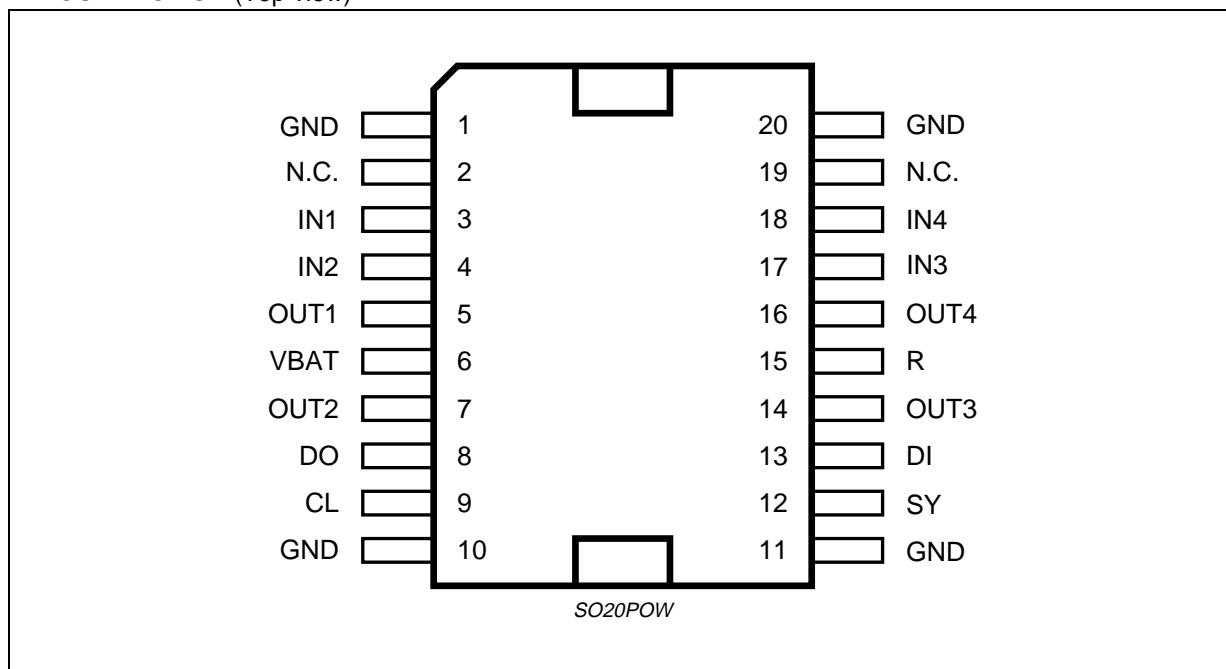
PIN CONNECTION (Top view)**PIN FUNCTION**

N°	Pin	Function
1, 10, 11, 20	GND	Ground
2, 19	N.C.	Not Connected
3	IN1	Input 1
4	IN2	Input 2
5	OUT1	Output 1
6	VBAT	Supply Voltage
7	OUT2	Output 2
8	DO	Serial Data Out
9	CL	Clock
12	SY	Synchronization
13	DI	Serial Data In
14	OUT3	Output 3
15	R	Reset
16	OUT4	Output 4
17	IN3	Input 3
18	IN4	Input 4

ABSOLUTE MAXIMUM RATINGS

Symbol	Parameter	Value	Unit
T _{STG}	Storage Temperature	-55 to 150	°C
T _J	Operating Junction Temperature	-40 to 150	°C
V _{BAT}	DC Supply Voltage	-2 to 30	V
V _{BATtr}	Transient Supply Voltage; t < 400ms	40	V
V _{OUT}	Output Voltage	65	V
V _{OUTtr}	Transient Output Voltage; during clamping	78	V
E _{CL}	Output Clamping energy; repetition rate < 100 Hz	10	mJ
-I _{OUT}	Output reverse current	2	A
V _R , V _{INI} , V _{DI} , V _{CLVSY}	Control Input voltage	-0.3 to 6.5	V
V _{DO}	Control Output voltage	-0.3 to 6.5	V

THERMAL DATA

Symbol	Parameter	Value	Unit
R _{th j-case}	Thermal Resistance Junction to Case	2.5	°C/W

ELECTRICAL CHARACTERISTICS (6.5V < V_{BAT} < 25V, -40 < T_J < 150°C)

Symbol	Parameter	Test Condition	Min.	Typ.	Max.	Unit
Supply Voltage						
V _{BATU}	Turn on threshold voltage		2.0		4.7	V
I _{BAT}	Supply current	V _{BAT} = 14V V _{OUTi} > 0V	4	10	15	mA
Output stage						
R _{DSOn}	On resistance	V _{BAT} = 14V T _J = 25°C; I _{out} = 1A			500	mΩ
		V _{BAT} = 14V T _J = 150°C; I _{out} = 1A			850	mΩ
V _{CL}	Clamping voltage, inductive load	I _{out} = 0.5 A	63	70	76	V
I _{OUTi}	Over current shutdown (Shutdown latch resets with pos. slope at INi)	T _J = -40°C	3.0		4.3	A
		T _J = 25°C	2.5		3.7	A
		T _J = 150°C	2.2		3.5	A
Output leakage current see: Open load diagnostic current						

ELECTRICAL CHARACTERISTICS (continued)

Symbol	Parameter	Test Condition	Min.	Typ.	Max.	Unit
Logic Inputs IN1...IN4, SY, CL, DI, R						
V _{INiLH} V _{SYLH} V _{CLLH} V _{RLH} V _{DILH}	Input High level		3.5		6.5	V
V _{INiHL} V _{SYHL} V _{CLHL} V _{RHL} V _{DIHL}	Input Low level		-0.3		1.5	V
V _{INih} V _{SYh} V _{CLh} V _{Rh} V _{Dih}	Hysteresis		0.2		1	V
- I _{INi} - I _{SY} - I _{CL} - I _R	Input current IN1 ... IN4, SY, CL, R (Internal pull up current source)	V _{INi} = 0V	10	40	120	μA
		V _{SY} = 0V V _{CL} = 0V V _R = 0V	10		80	
- I _{DI}	Input current DI (Internal pull up current source)	V _{DI} = 0V	120	220	250	μA
Timing						
t _{don}	Turn on delay			7.5		μs
t _{doff}	Turn off delay			7.5		μs
s _{on}	Switch on slew rate			10		V/μs
s _{off}	Switch off slew rate			15		V/μs
t _{oc}	Over current detection time			0.5		μs
t _v	Open load filtering time		60	100	200	μs
t _v	Short to GND filtering time		60	100	200	μs
f _{CL}	Serial clock frequency		0		500	kHz
t _{VDV}	DO: Data valid time		0.03		1	μs
t _{vset}	DI: Data settling time		0.5			μs
t _{vhold}	DI: Data hold time		0			μs
Diagnostic						
V _{BATDU}	Under voltage threshold		4.7		7.5	V
Serial Data output (External pull up required)						
V _{DO}	Data output low voltage	I _{DO} < 1.6mA 7.5V < V _{BAT} < 22V	0		0.45	V
I _{DO}	Data output leakage current				10	μA

ELECTRICAL CHARACTERISTICS (continued)

Symbol	Parameter	Test Condition	Min.	Typ.	Max.	Unit
Output voltage monitoring Output off						
V_{OL}	Open load threshold voltage (fault detected if $V_{OUTi} < V_{OL}$)	$7.5V < V_{BAT} < 22V$		$2/3V_{BAT}$		
V_{SG}	Short to GND threshold voltage (fault detected if $V_{OUTi} < V_{SG}$)	$7.5V < V_{BAT} < 22V$		$1/3V_{BAT}$		
Open load diagnostic current Output off						
	Open load output voltage	$I_{OUT} = 0 A$ $V_{INi} = 5V$ $7.5V < V_{BAT} < 22V$		$1/2V_{BAT}$		
$-I_{OUTi}$	Output current	$V_{OUT} = 1V$ $V_{INi} = 5V$	50	100	150	μA
I_{OUTi}	Output current	$V_{OUT} = V_{BAT}$ $V_{INi} = 5V$ $7.5V < V_{BAT} < 22V$	200	320	500	μA
Overload Diagnostic						
	Over temperature diagnostic	T_J		175		$^{\circ}C$
I_{OUTi}	Over current	$T_J = -40^{\circ}C$	3.0		4.3	A
		$T_J = 25^{\circ}C$	2.5		3.7	A
		$T_J = 150^{\circ}C$	2.2		3.5	A

Figure 1. Typical Timing Diagram for Serial Diagnostic

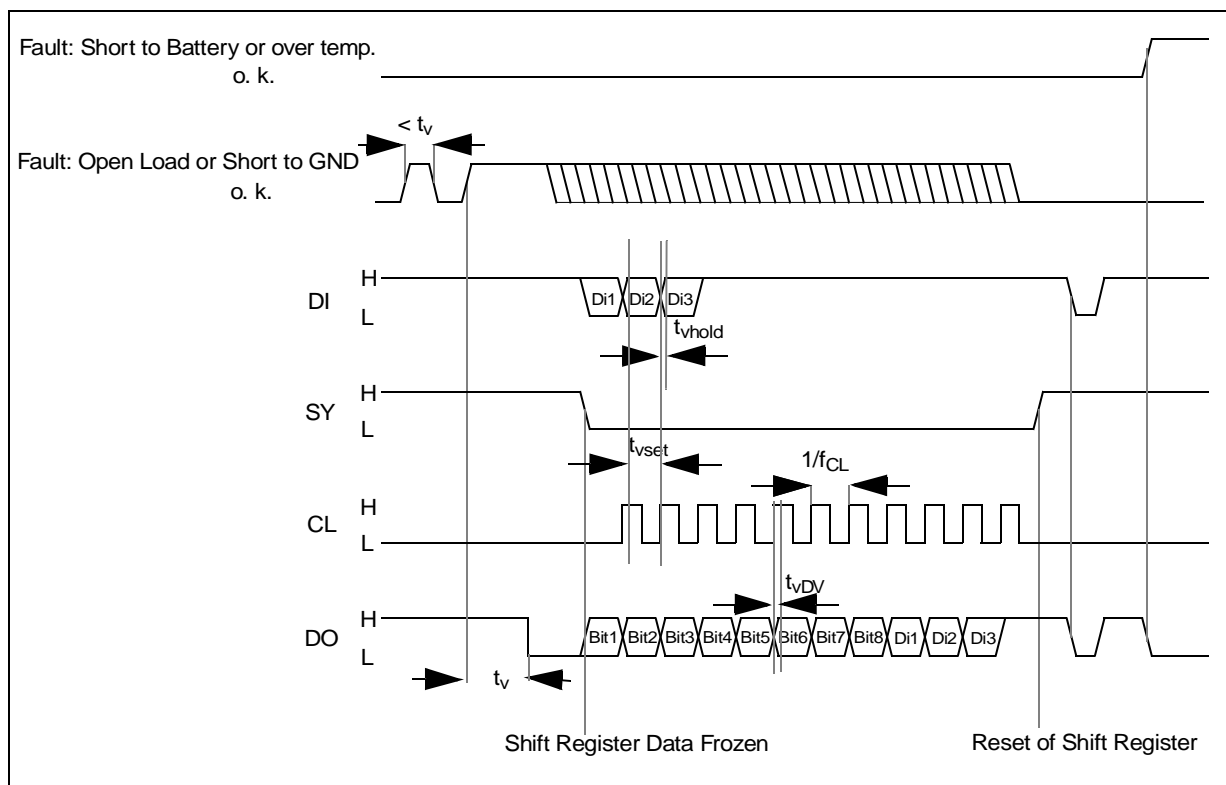

Figure 2. Serial Interface Error Coding

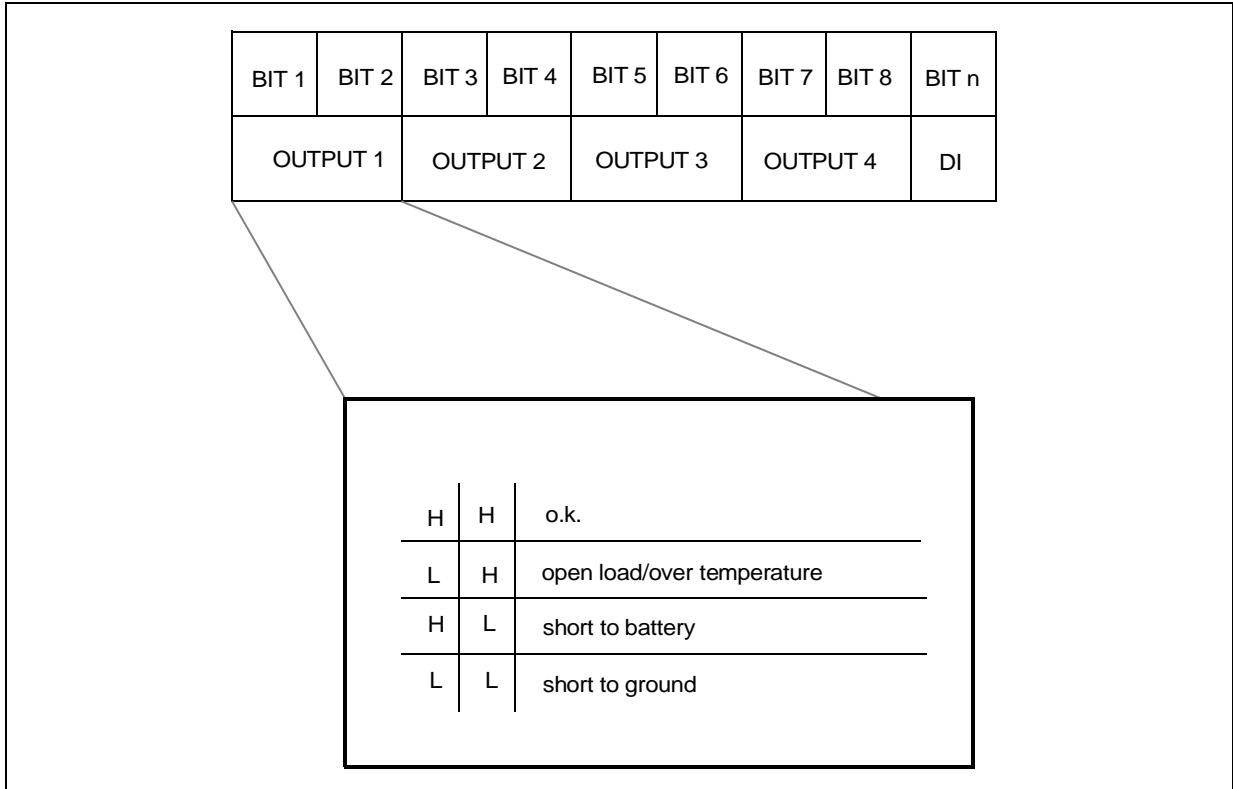

Figure 3. Output voltage TIMING for inductive load

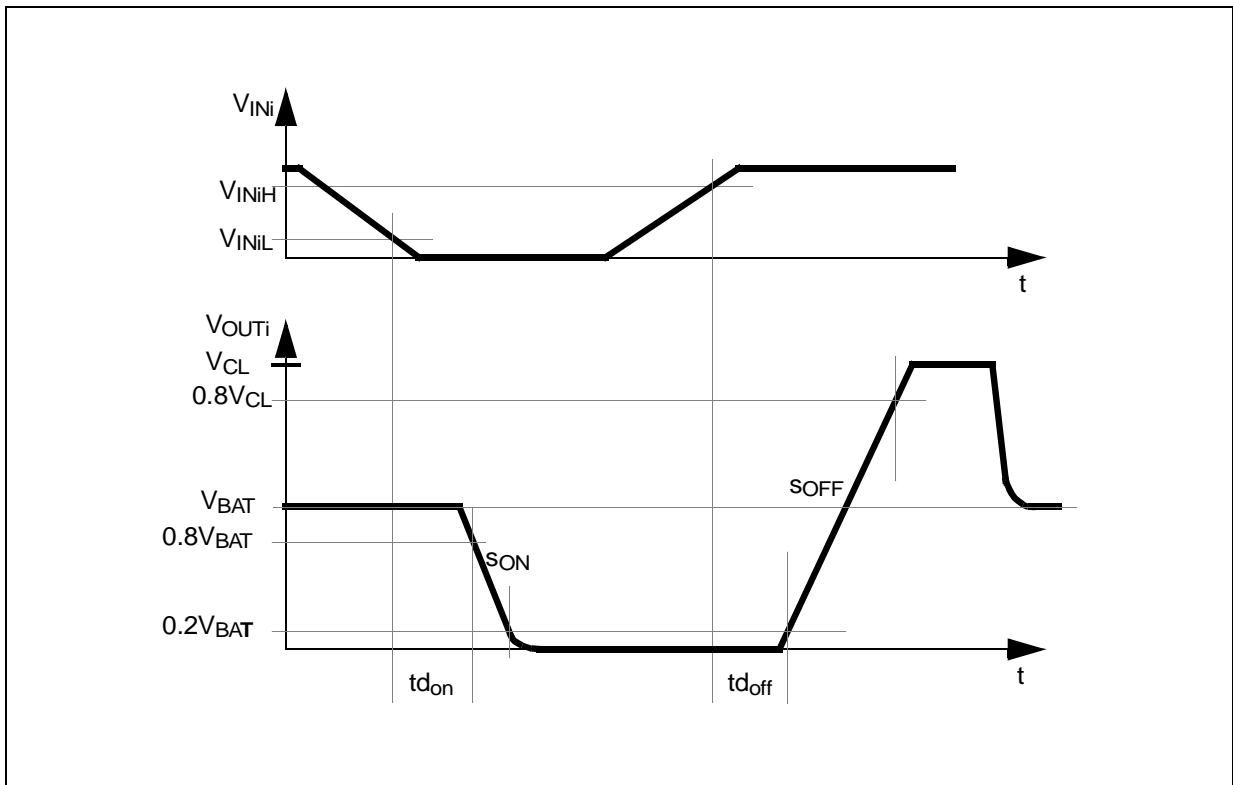
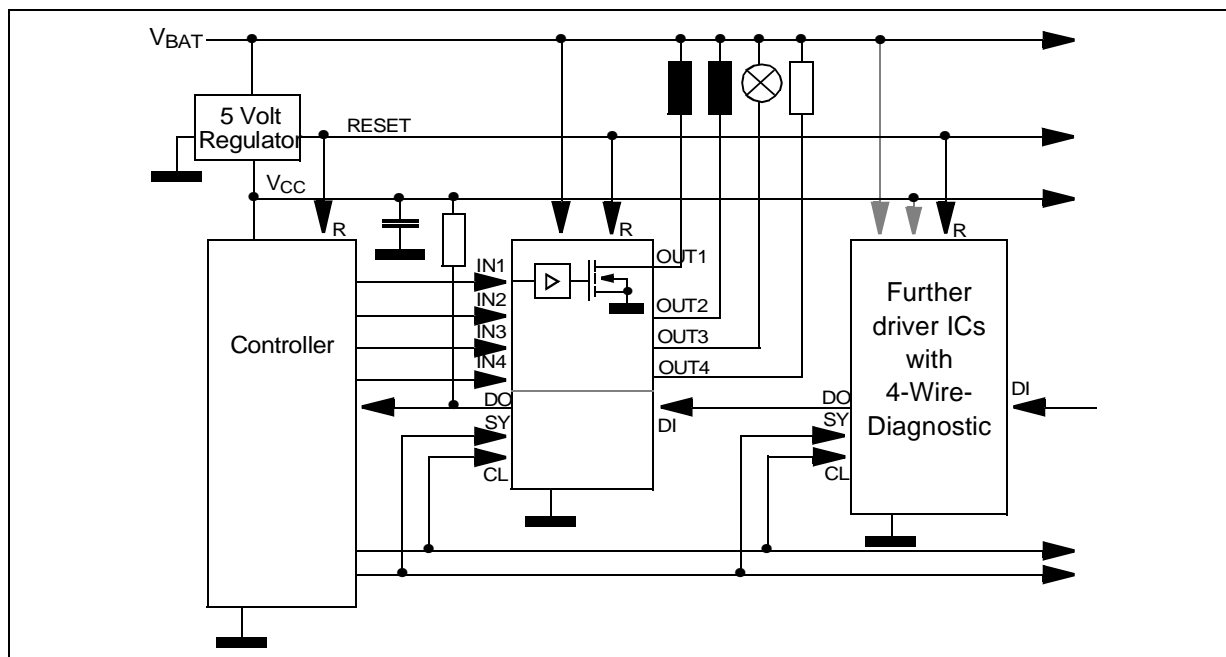

Figure 4. Application Circuit



DIM.	mm			inch		
	MIN.	TYP.	MAX.	MIN.	TYP.	MAX.
A			3.6			0.142
a1	0.1		0.3	0.004		0.012
a2			3.3			0.130
a3	0		0.1	0.000		0.004
b	0.4		0.53	0.016		0.021
c	0.23		0.32	0.009		0.013
D (1)	15.8		16	0.622		0.630
D1	9.4		9.8	0.370		0.386
E	13.9		14.5	0.547		0.570
e		1.27			0.050	
e3		11.43			0.450	
E1 (1)	10.9		11.1	0.429		0.437
E2			2.9			0.114
E3	5.8		6.2	0.228		0.244
G	0		0.1	0.000		0.004
H	15.5		15.9	0.610		0.626
h			1.1			0.043
L	0.8		1.1	0.031		0.043
N	10° (max.)					
S	8° (max.)					
T		10			0.394	

(1) "D and F" do not include mold flash or protrusions.
 - Mold flash or protrusions shall not exceed 0.15 mm (0.006").
 - Critical dimensions: "E", "G" and "a3"

OUTLINE AND MECHANICAL DATA

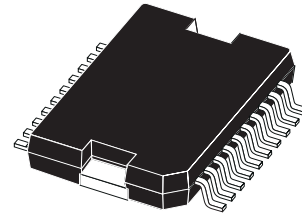

JEDEC MO-166

PowerSO20

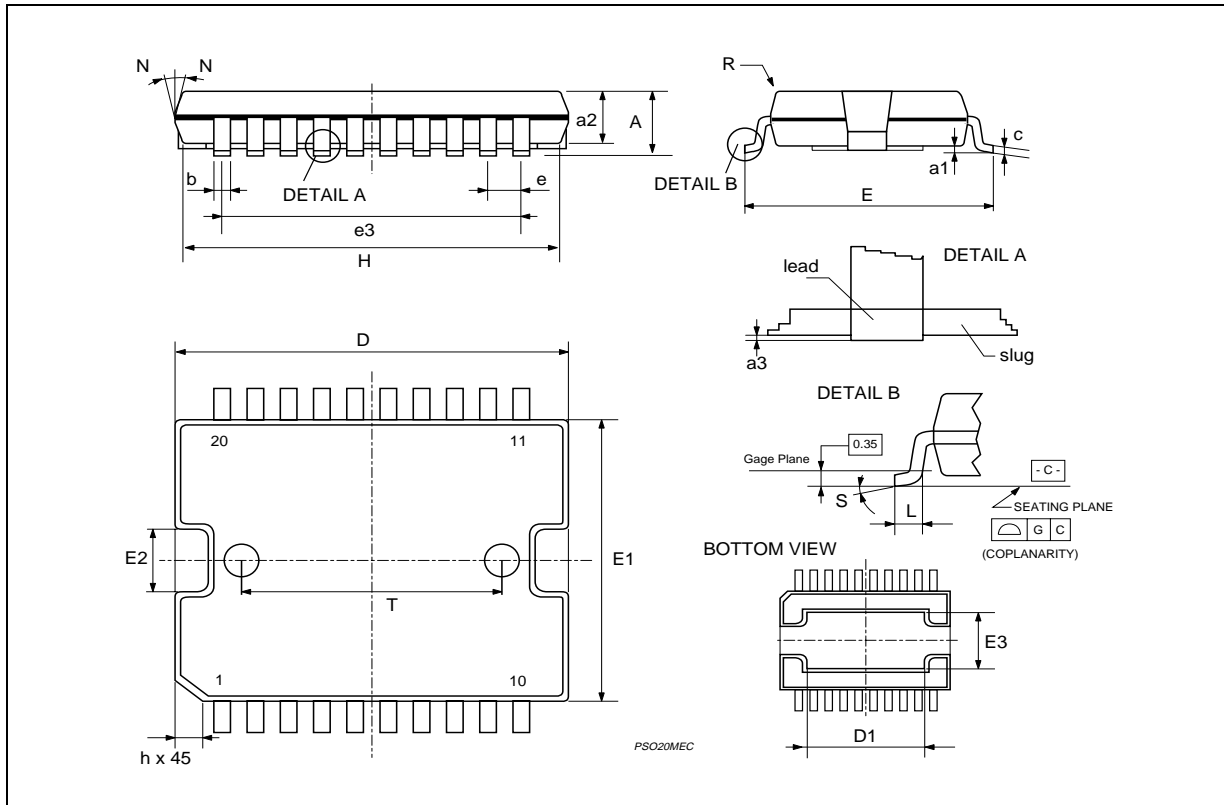

Information furnished is believed to be accurate and reliable. However, STMicroelectronics assumes no responsibility for the consequences of use of such information nor for any infringement of patents or other rights of third parties which may result from its use. No license is granted by implication or otherwise under any patent or patent rights of STMicroelectronics. Specifications mentioned in this publication are subject to change without notice. This publication supersedes and replaces all information previously supplied. STMicroelectronics products are not authorized for use as critical components in life support devices or systems without express written approval of STMicroelectronics.

The ST logo is a registered trademark of STMicroelectronics
© 2001 STMicroelectronics - All Rights Reserved

STMicroelectronics GROUP OF COMPANIES
Australia - Brazil - China - Finland - France - Germany - Hong Kong - India - Italy - Japan - Malaysia - Malta - Morocco - Singapore - Spain
- Sweden - Switzerland - United Kingdom - U.S.A.
<http://www.st.com>