

CAN BUS TRANSCEIVER

- L9615 MEETS ISO/DIS 11898 UP TO 500KBAUD
- TRANSMITTER
 - GENERATION OF DIFFERENTIAL OUTPUT SIGNALS
 - SHORT CIRCUIT PROTECTED FROM -5V TO 36V, DETECTION & SHUTDOWN
 - SLOPE CONTROL TO REDUCE RFI AND EMI
 - TWO STATES ADJUSTABLE SLOPE CONTROL ($\leq 500\text{KBAUD}/\leq 125\text{KBAUD}$)
- RECEIVER
 - DIFFERENTIAL INPUT WITH HIGH INTERFERENCE SUPPRESSION
 - COMMON MODE INPUT VOLTAGE RANGE (V_{COM}) FROM -2V TO $V_{\text{S}}+3\text{V}$
- PACKAGE: SO 8

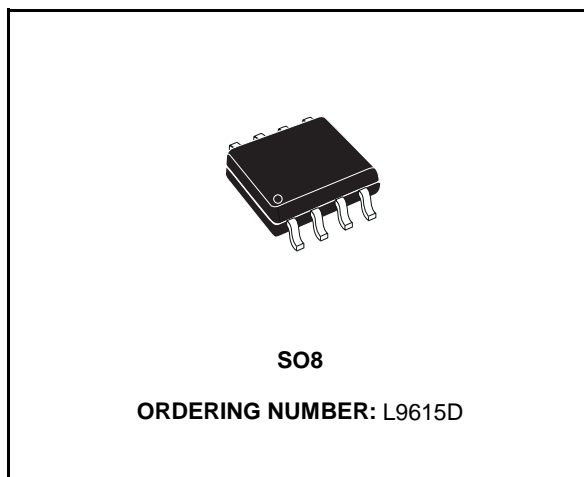

DESCRIPTION

The L9615 is a bidirectional transceiver for signal

conditioning and processing in connection with a CAN controller. Data rates of up to 500KBAUD are supported using either shielded or non-shielded pair of lines.

BLOCK DIAGRAM

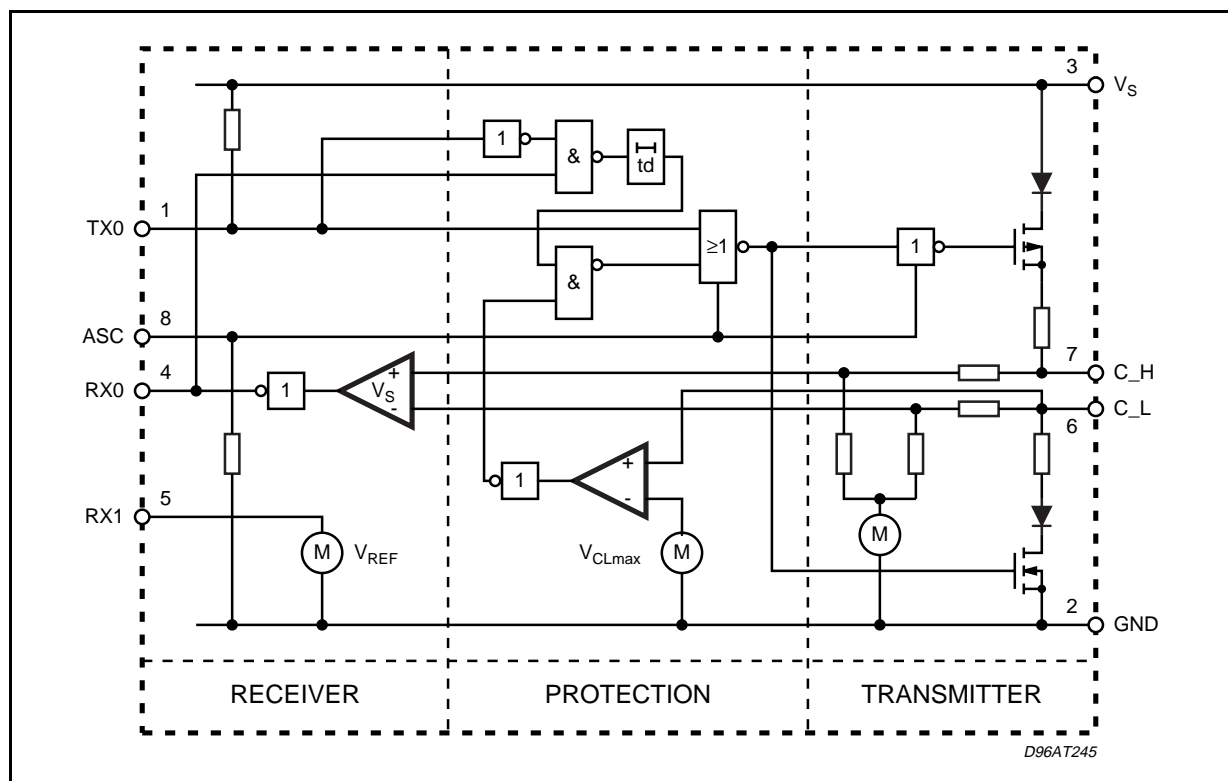

ABSOLUTE MAXIMUM RATINGS

Symbol	Parameter	Value	Unit
V_S	Supply Voltage	-0.3 to 7	V
V_{C_H}, V_{C_L}	Bus Voltage at C_H, C_L (VS 0 to 5.5V)	-5 to 36	V
I_{C_H}, I_{C_L}	Off State Leakage Current at C_H, C_L (VS =0 to 5.5V, $V_{C_H} = -5$ to 36V, $V_{C_L} = -5$ to 36)	-3 to 5	mA
V_{DC}	DC Voltage at TXO, ASC (VS 0 to 5.5V)	GND -0.3 to $V_S + 0.3$	V
I_{RXO}	Output Current at RXO (VS 0 to 5.5V)	-0.3 to 1	mA
T_{stg}, T_J	Storage and Junction Temperature Range	-40 to 150	°C
T_{op}	Operating Temperature Range	-40 to 110	°C

All voltages, except bus voltage, are defined with respect to pin 2
 Positive currents flow into the IC.

PIN CONNECTION

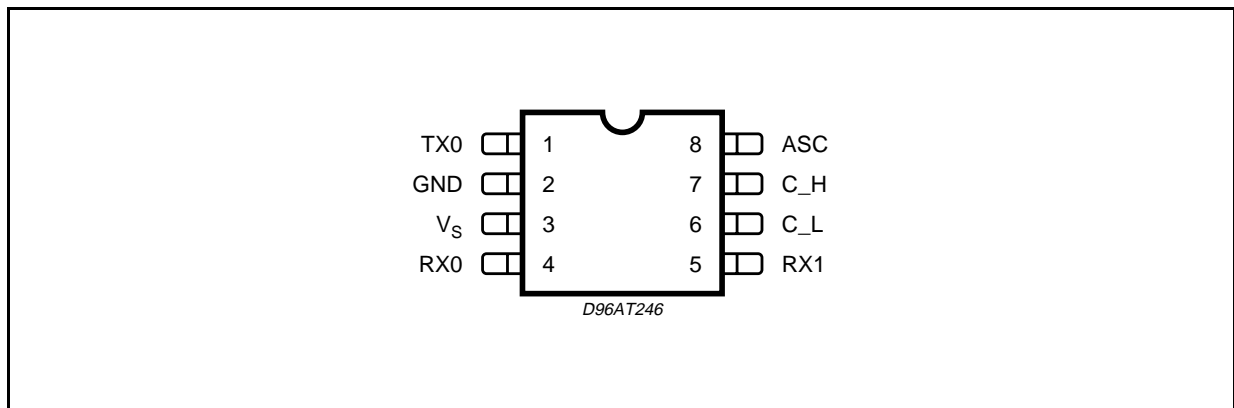

THERMAL DATA

Symbol	Parameter	Value	Unit

PIN FUNCTIONS

N.	Name	Function
1	TXO	Transmitter Input
2	GND	Ground
3	V_S	Supply Voltage
4	RXO	Receive Output
5	RX1	Reference Voltage
6	C_L	Low Side Bus Output
7	C_H	High Side Bus Output
8	ASC	Adjustable Slope Control

ELECTRICAL CHARACTERISTICS ($T_{OP} = -40$ to 110°C ; $V_S = 4.5$ to 5.5V ; Dominant: $V_{TXO} = \text{GND}$; Recessive: $V_{TXO} = V_S$; All voltages, except bus voltage, are defined with respect to pin 2. Positive currents flow into the IC unless otherwise specified.)

Symbol	Parameter	Test Condition	Min.	Typ.	Max.	Unit
V_S	Supply Voltage		4.5	5	5.5	V
I_S	Supply Current	Dominant			80	mA
		Recessive			20	mA
TRANSMITTER SECTION ($R_A = 60\Omega$ between C_H and C_L)						
C_{TXO}	TXO Input Capacitance	$0\text{V} < V_{TXO} < V_S$		25		pF
V_{TXO}	TXO High Level Input Voltage		$0.7 V_S$		V_S	
	TXO Low Level Input Voltage		0		$0.3 V_S$	
I_{TXO}	TXO High Level Input Current	$V_{TXO} = V_S$	-2	0	2	μA
	TXO Low Level Input Current	$V_{TXO} = \text{GND}$	-275	0	-25	μA
C_{ASC}	ASC Input Capacitance	$0\text{V} < V_{ASC} < V_S$		25		pF
V_{ASC}	ASC Input Voltage for High Speed		0		$0.1 V_S$	
	ASC Input Voltage for Low Speed		$0.9 V_S$		V_S	
I_{ASC}	ASC Input Current	$V_{ASC} = V_S$	25		275	μA
		$V_{ASC} = 0\text{V}$	-2	0	2	μA
V_{C_H}, V_{C_L}	Bus Voltage Recessive	Recessive	$0.4 V_S$	$0.5 V_S$	$0.6 V_S$	
I_{C_H}, I_{C_L}	Leakage Current Recessive	$V_{C_L} = V_{C_H} = -2$ to 7V	-0.7		0.7	mA
		$V_{C_L} = V_{C_H} = 1$ to 4V	-0.3		0.3	mA
$R_{IN}(C_H, C_L)$	Input Resistance	Recessive	5		50	$\text{K}\Omega$
$R_{DIFF}(C_H, C_L)$	Differential Input Resistance	Recessive	10		100	$\text{K}\Omega$
$V_{DIFF} = V_{C_H} - V_{C_L}$	Differential Output Voltage	Dominant, R_A	1.5		3	V
$V_{DIFF} = V_{C_H} - V_{C_L}$	Differential Output Voltage	Recessive	-500	0	50	mV
t_d	Short Circuit Detection Time C_H to C_L ; C_H to B	$R_{CS} < 1\Omega$	1	5	10	μs
I_A	Supply Current in Case of Short Circuit, C_H to C_L , C_H to B (time = t_d)			150		mA
V_{C_Lmax}	Overvoltage Protection Threshold on C_L		7	8	10	V
RECEIVE SECTION						
V_{RXO}	RXO High Level Output Voltage	$V_{DIFF} < 0.5\text{V}$; $I_{RXO} = 0.3\text{mA}$; $V_{C_H} = -2$ to 7V ; $V_{C_L} = -2$ to 7V ;	$0.9 V_S$		V_S	V
	RXO Low Level Output Voltage	$V_{DIFF} > 0.9\text{V}$; $I_{RXO} = 1\text{mA}$; $V_{C_H} = -2$ to 7V ; $V_{C_L} = -2$ to 7V ;			0.5	V
$V_S = V_{C_H} - V_{C_L}$	Input Signal Threshold	$V_{C_H} = -2$ to 7V ; $V_{C_L} = -2$ to 7V ;	500	700	900	mV
$V_{COM} = (V_{C_H} + V_{C_L})/2$	Input Common Mode Voltage Range		-2		7	V
V_{HYS}	Differential Input Hysteresis			150		mV
REFERENCE OUTPUT						
V_{RX1}	Reference Voltage	$I_{RX1} = 0$	$0.45 V_S$	$0.5 V_S$	$0.55 V_S$	V
R_{RX1}	Output Resistance		2		9	$\text{K}\Omega$

L9615

DINAMIC CHARACTERISTICS ($C_A = 47\text{pF}$ between C_H and C_L ; $V_S = 5\text{V}$; $t_R < 5\text{ns}$; $C_{RXO} = 20\text{pF}$ between RXO and B ; $R_A = 60\Omega$ between C_H and C_L)

Symbol	Parameter	Test Condition	Min.	Typ.	Max.	Unit
t_{OT}	Signal Delay TXO to C_H , C_L				50	ns
SR	Differential Output Slew Rate (Transmitter)	$V_{ASC} = 0\text{V}$	20		50	$\text{V}/\mu\text{s}$
		$V_{ASC} = V_S$	5		20	$\text{V}/\mu\text{s}$
t_{OR}	Signal Delay C_H , C_L to RXO	$V_{ASC} = 0\text{V}$			150	ns
t_{OTR}	Signal Delay Txo to Rxo	$V_{ASC} = 0\text{V}$			300	ns

FUNCTIONAL DESCRIPTION

The L9615 is used as an interface between a CAN controller and the physical bus. The device provides transmitting capability to the CAN controller.

The transmitter outputs C_H and C_L are protected against short circuits and electrical transients which may occur in an automotive environment. In case of short circuit (C_H to C_L , C_H to B) the protection circuit recognizes this fault condition and the transmitter output stages are disabled with a delay of max. $10\mu\text{s}$ to prevent destruction of the IC and high consumption of supply current I_S . If $V_{C_L} > V_{C_Lmax}$ the transmitter output stages would be disabled immediately.

Pin ASC makes it possible to select two different

modes of operation: High speed ($\leq 500\text{kBaud}$) and low speed ($\leq 125\text{kBaud}$).

The ASC pin is tied to GND for normal operation at $\leq 500\text{kBaud}$. For slower speed operation at $\leq 125\text{kBaud}$ the rise and fall slope of the bus output can be decreased to reduce EMI by connecting the ASC pin to V_S .

FUNCTIONAL TABLE

TXO	C_H	C_L	Bus State	RXO
L	H	L	Dominant	L
H or Floating	Floating $V_S/2$	Floating $V_S/2$	Recessive	H

TYPICAL APPLICATION

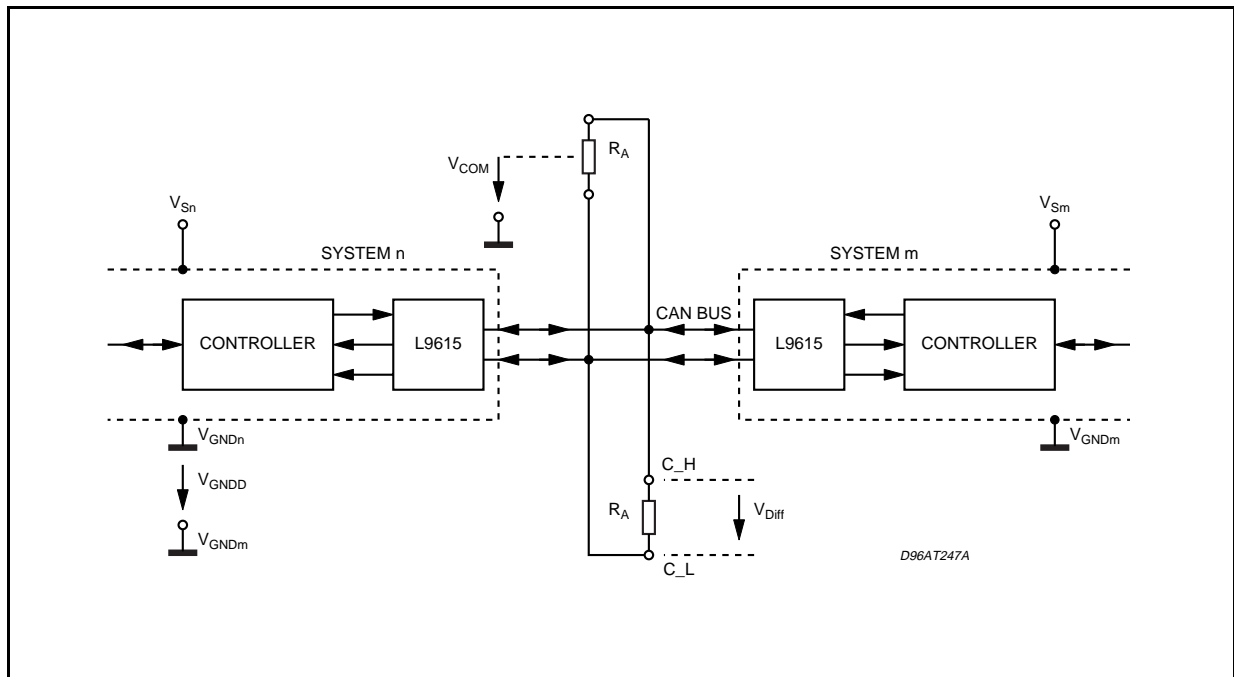

TIMING DIAGRAM



EMC PERFORMANCE (RECEIVER)



EMC PERFORMANCE (TRANSMITTER)



Transceiver Without Emc Reducing Measures

Transceiver With Emc Reducing Measures

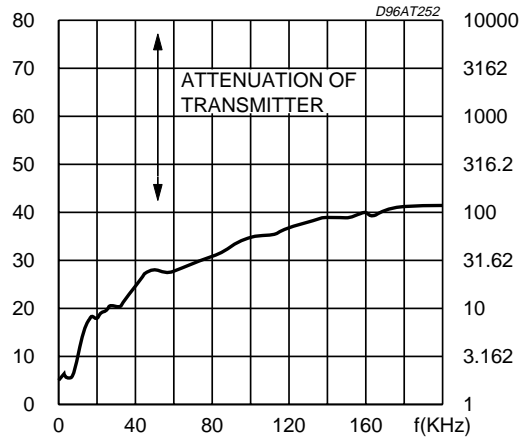
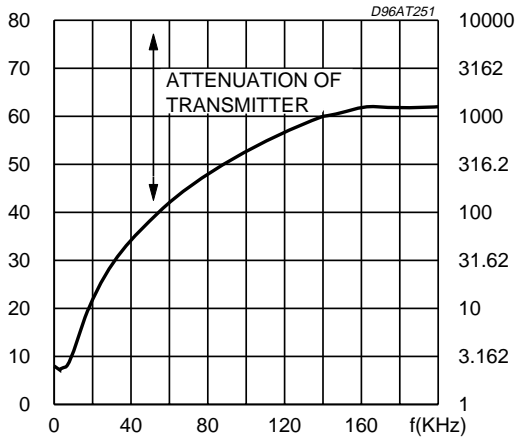

EMC PERFORMANCE (Transceiver Sending)

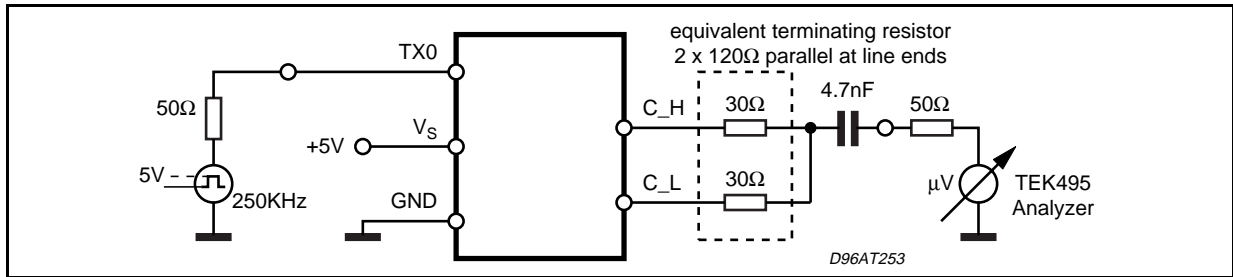

Transceiver Without Emc Reducing Measures

Transceiver With Emc Reducing Measures

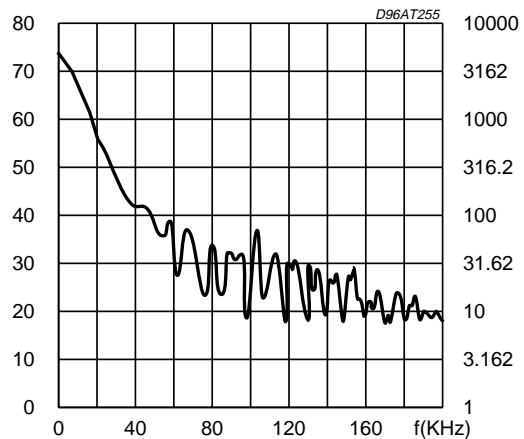
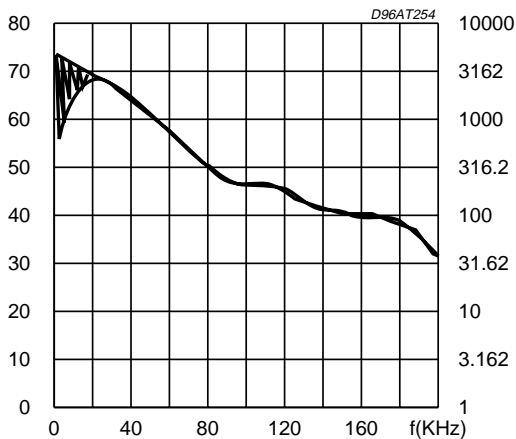

SO8 PACKAGE MECHANICAL DATA

DIM.	mm			inch		
	MIN.	TYP.	MAX.	MIN.	TYP.	MAX.
A			1.75			0.069
a1	0.1		0.25	0.004		0.010
a2			1.65			0.065
a3	0.65		0.85	0.026		0.033
b	0.35		0.48	0.014		0.019
b1	0.19		0.25	0.007		0.010
C	0.25		0.5	0.010		0.020
c1	45° (typ.)					
D	4.8		5.0	0.189		0.197
E	5.8		6.2	0.228		0.244
e		1.27			0.050	
e3		3.81			0.150	
F	3.8		4.0	0.15		0.157
L	0.4		1.27	0.016		0.050
M			0.6			0.024
S	8° (max.)					

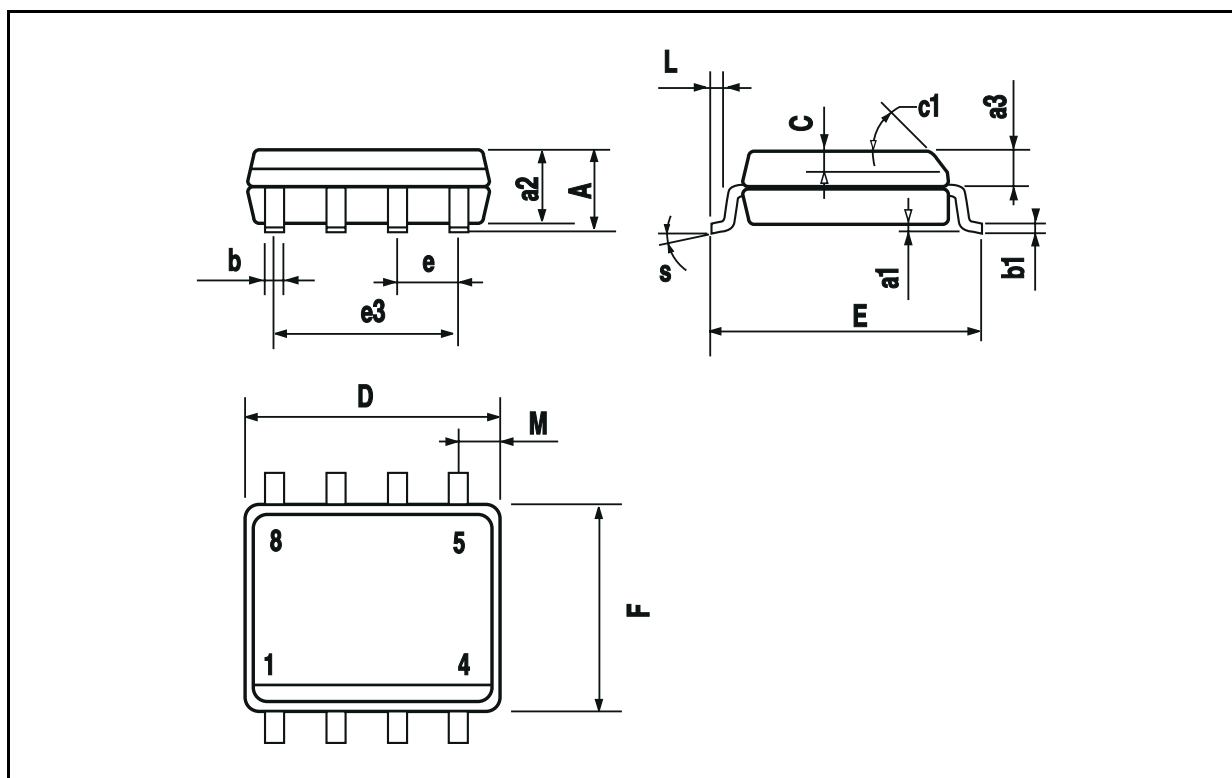

Information furnished is believed to be accurate and reliable. However, SGS-THOMSON Microelectronics assumes no responsibility for the consequences of use of such information nor for any infringement of patents or other rights of third parties which may result from its use. No license is granted by implication or otherwise under any patent or patent rights of SGS-THOMSON Microelectronics. Specification mentioned in this publication are subject to change without notice. This publication supersedes and replaces all information previously supplied. SGS-THOMSON Microelectronics products are not authorized for use as critical components in life support devices or systems without express written approval of SGS-THOMSON Microelectronics.

© 1998 SGS-THOMSON Microelectronics – Printed in Italy – All Rights Reserved

SGS-THOMSON Microelectronics GROUP OF COMPANIES

Australia - Brazil - Canada - China - France - Germany - Italy - Japan - Korea - Malaysia - Malta - Morocco - The Netherlands -
Singapore - Spain - Sweden - Switzerland - Taiwan - Thailand - United Kingdom - U.S.A.