

DATA INTERFACE

- OPERATING POWER SUPPLY VOLTAGE RANGE $4.8V \leq V_s \leq 36V$ (40V FOR TRANSIENTS)
- REVERSE SUPPLY (BATTERY) PROTECTED DOWN TO $V_s \geq -24V$
- STANDBY MODE WITH VERY LOW CURRENT CONSUMPTION $I_{SSB} \leq 1\mu A @ V_{CC} \leq 0.5V$
- MIN POSSIBLE BAUD RATE ACCORDING TO ISO9141 $\geq 130KBAUD$
- TTL COMPATIBLE TX INPUT
- BIDIRECTIONAL K-I/O PIN WITH SUPPLY VOLTAGE DEPENDENT INPUT THRESHOLD
- OVERTEMPERATURE SHUT DOWN FUNCTION SELECTIVE TO K-I/O PIN
- WIDE INPUT AND OUTPUT VOLTAGE RANGE $-24V \leq V_K \leq V_S$
- K OUTPUT CURRENT LIMITATION, $TYP I_K = 60mA$
- DEFINED OFF OUTPUT STATUS IN UNDER-VOLTAGE CONDITION AND V_S OR GND INTERRUPTION
- CONTROLLED OUTPUT SLOPE FOR LOW EMI
- HIGH INPUT IMPEDANCE FOR OPEN V_S OR GND CONNECTION

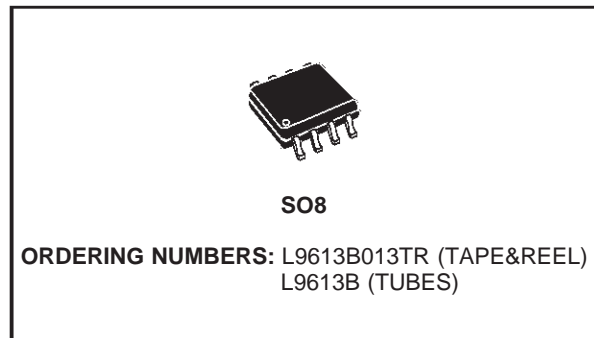

- DEFINED OUTPUT ON STATUS OF LO OR RX FOR OPEN LI OR K INPUTS
- DEFINED K OUTPUT OFF FOR TX INPUT OPEN
- INTEGRATED PULL UP RESISTORS FOR TX, RX AND LO
- EMI ROBUSTNESS OPTIMIZED

DESCRIPTION

The L9613B is a monolithic integrated circuit containing medium speed data interface functions.

BLOCK DIAGRAM

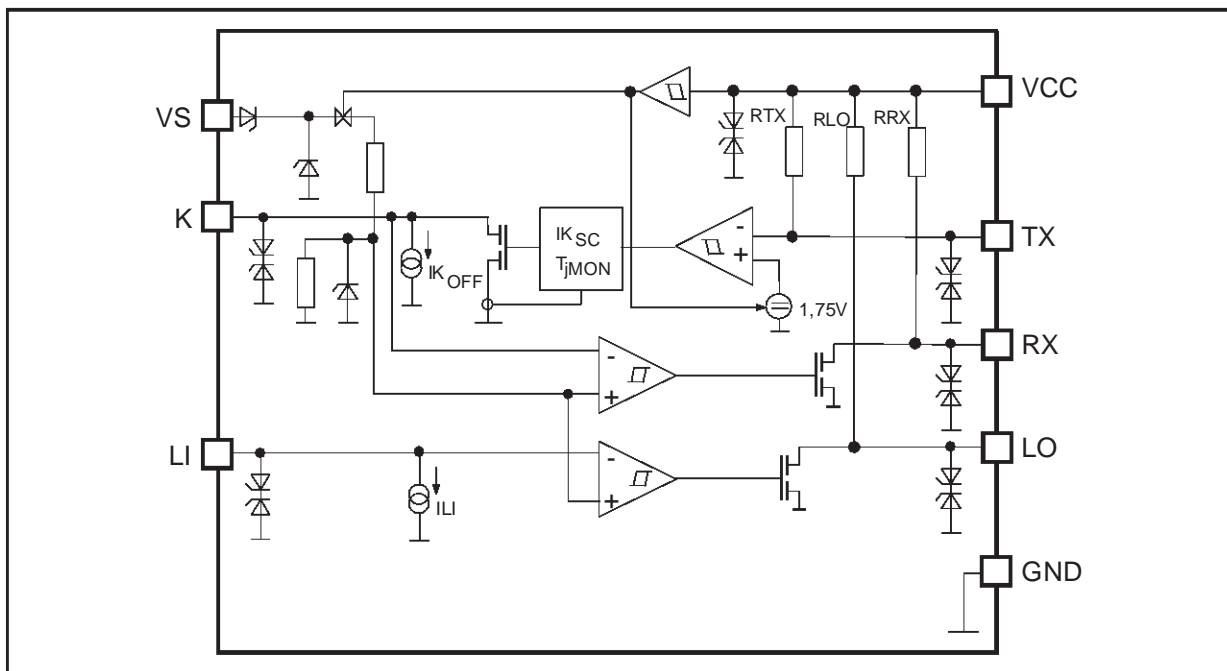

ABSOLUTE MAXIMUM RATINGS

Symbol	Parameter	Value	Unit
V_S	Supply Voltage	-24 to +36	V
	ISO transient $t \leq 400\text{ms}$	-24 to +40	V
V_{CC}	Stabilized Voltage	-24V to 7	V
dV_S/dt	Supply Voltage Transient	-10 to +10	V/ μs
$V_{LI,K}$	Pin voltage	-24 to V_S	V
$V_{LO,RX,TX}$	Pin voltage	-24 to V_{CC}	V

* max ESD voltages are +/-2KV with human body model C=100pF, R=1.5K Ω corresponds to maximum energy

PIN CONNECTION

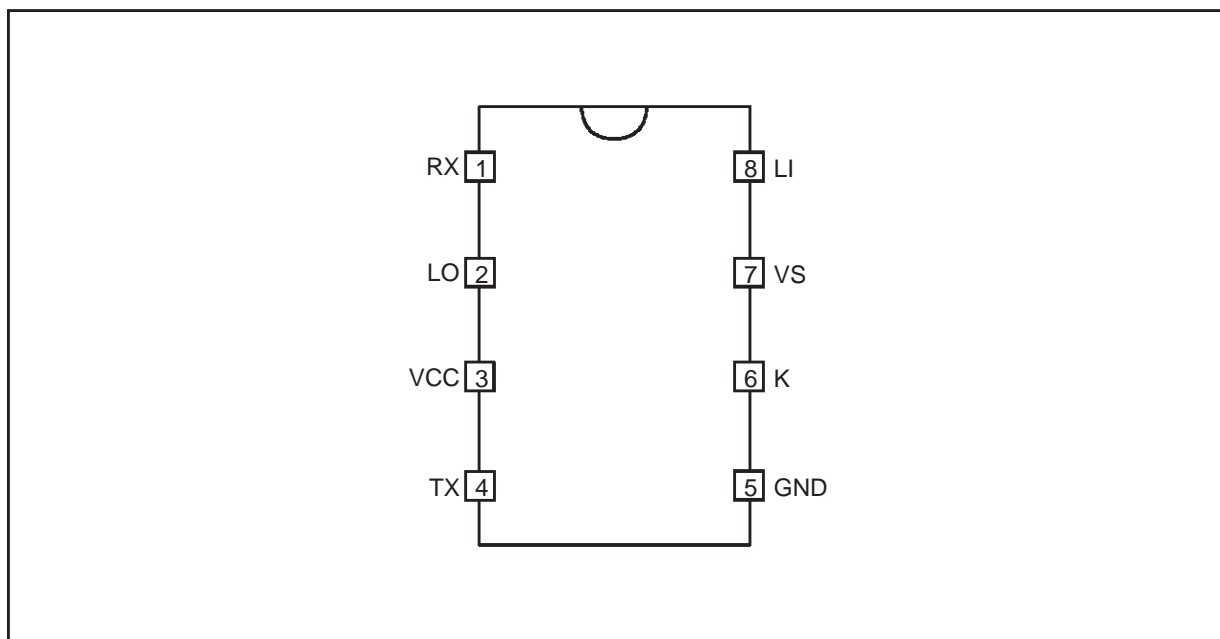

THERMAL DATA

Symbol	Parameter	Min.	Typ.	Max.	Unit
T_{JSDon}	Temperature shutdown switch-on-threshold	160		200	$^{\circ}\text{C}$
T_{JSDoff}	Temperature shutdown switch-off-threshold	150			$^{\circ}\text{C}$
$R_{th(j-a)}$	Thermal steady state junction to ambient resistance	130	155	180	$^{\circ}\text{C}/\text{W}$

PIN FUNCTIONS

N.	Name	Description
1	RX	Output for K as input
2	LO	Output L comparator
3	VCC	Stabilized voltage supply
4	TX	Input for K as output
5	GND	Common GND
6	K	Bidirectional I/O
7	VS	Supply voltage
8	LI	Input L comparator

ELECTRICAL CHARACTERISTICS (The electrical characteristics are valid within the below defined Operating Conditions, unless otherwise specified).

The function is guaranteed by design until T_{JSDon} temperature shutdown switch-on-threshold.

V_S Supply voltage 4.8 V... 18 V

V_{CC} Stabilized voltage 3 V... 7 V

T_J Junction temperature -40 °C... 150 °C

Symbol	Parameter	Test Condition	Min.	Typ.	Max.	Unit
I_{CC}	Supply V_{CC} Current	$V_{CC} \leq 5.5V$ $V_{LI}, V_{TX} = 0V$		1.4	2.5	mA
		$V_K \geq V_{K_{high}}$ $V_{LI} \geq V_{LI_{high}}$ $V_{TX} = V_{CC}$ @ $V_{CC} \leq 5.5V$	-5	40	150	μA
I_{SON}	Supply V_S Current	$V_{LI}, V_{TX} = 0V$		3.5	10	mA
		$V_{CC} = 0.5V$ @ $V_S \leq 12V$ 3)		<1	50	μA
I_{SBS}		$V_{CC} = 0.5V$, see fig. 5 @ $V_S \leq 16V$			100	μA
$V_{K_{low}}$	Input Voltage LOW State	RX output status LOW	-24		0.40VS	V
$V_{K_{high}}$	Input Voltage HIGH State	RX output status HIGH	0.60VS		VS	V
$V_{K_{hys}}$	Input Threshold Hysteresis	$V_{K_{high}} - V_{K_{low}}$ $V_S \geq 8.0V$ $V_S \geq 6.0V$	0.2 0.08	0.05VS	1.0	V V
I_{KOFF}	Input Current	$V_{TX} \geq V_{TX_{high}}$ $V_S, V_{CC} \geq 0V$ or $V_S,$ $V_{CC} = \text{open}$ or $GND = \text{open}$	-5	4	40	μA
R_{KON}	Output ON Impedance	@ $V_S \geq 6.5V$ $V_{TX} \leq V_{TX_{low}}$ $I_K \geq 7mA$ 1)		10	30	Ω
I_{KSC}	Short Circuit Current	$V_S \geq 6.5V$	40	60	150	mA
$V_{K_{sat}}$	Output Saturation Voltage	$R_{KO} = 1.5K\Omega$			1	V
$V_{TX_{low}}$	Input Voltage LOW State		-24		1	V
$V_{TX_{high}}$	Input Voltage HIGH State		3.5		V_{CC}	V
R_{RXON} R_{LOON}	Output ON Impedance	$V_K \leq V_{K_{low}}; V_{LI} \leq V_{LI_{low}}$ $V_S \geq 6.5V; I_{RX,LO} \geq 1mA$		40	90	Ω
$V_{RX_{sat}}$ $V_{LO_{sat}}$	Saturation Output Voltage	No external load			1	V
I_{RXSC} I_{LOSC}	Output short circuit current	$V_S \geq 6.5V$	9	20	50	mA
RTX	Input pull up resistance	Output status = (HIGH) $T_A \leq 85^\circ C$ $-0.15V \leq V_{LO} \leq V_{CC} + 0.15V$ $-0.15V \leq V_{RX} \leq V_{CC} + 0.15V$	5	10	18	k Ω
RTX	Input pull up resistance	$-0.15V \leq V_{TX} \leq V_{CC} + 0.15V$ $T_{amb} \leq 125^\circ C$	10	20	40	k Ω
$V_{LI_{low}}$	Input voltage LOW state	LO output status LOW	-24		0.40VS	V
$V_{LI_{high}}$	Input voltage HIGH state	LO output status HIGH	0.60VS		VS	V
ILI	Input current	$V_S, V_{CC} \geq 0V$ or $V_S, V_{CC} = \text{open}$ or $GND = \text{open}$	-5	4	40	μA

Note 1) For external supplied output currents lower than this value a series protection diode can become active. See also Fig. 4 and 5.

ELECTRICAL CHARACTERISTICS (continued)

Symbol	Parameter	Test Condition	Min.	Typ.	Max.	Unit
$C_{KI,LO,RX}$	Internal output capacities				20	pF
f_{LI-LO} f_{K-RX} f_{TX-K}	Transmission frequency	$9V < V_S < 16V$, (external loads) $T_{min} \geq 20 \cdot R_{KO} \cdot C_K - K_{line}$	130			kHz
f_{LI-LO} f_{K-RX} f_{TX-K}	Rise Time	for the definition of t_r , t_f see FIG. 1, 2)		0.4	2	μs
	Fall Time	$9V < V_S < 16V$, (external loads) $T_{min} \geq 20 \cdot R_{KO} \cdot C_K - K_{line}$		0.4	2	μs
$t_{OFF,LI-LO}$ $t_{OFF,K-RX}$ $t_{OFF,TX-K}$	Switch OFF time	for the definition of t_r , t_f see FIG. 1		1.3	3	μs
$t_{ON,LI-LO}$ $t_{ON,K-RX}$ $t_{ON,TX-K}$	Switch ON time	$9V < V_S < 16V$, (external loads) $T_{min} \geq 20 \cdot R_{KO} \cdot C_K - K_{line}$		1.3	3	μs
$t_{dSB ON}$	Standby reaction time	$V_{TX} = 0V$, $I_K \geq 7mA$		10	20	μs
$t_{dSB OFF}$		$V_{LI} = 0V$, $9V < V_S < 16V$ see FIG. 2		20	40	μs

Note 2) Speed limitation related to external capacitance $C_{extRX, LO}$ and internal impedance $C_{LO,RX, RLO, RRX}$ for rise time.

$$t_r = R_{LO,RX} \cdot (C_{LO,RX} + C_{extRX, LO}) \cdot 1.38.$$

Note 3) In case of spikes on $V_{CC} \geq 0.5V$ KOUT will be switched On for typical $10\mu s$ which represents the standby t_{dSB} reaction time.

FUNCTIONAL DESCRIPTION

The L9613B is a monolithic bus driver designed to provide bidirectional serial communication in automotive applications.

The device provides a bidirectional link, called K, to the V_{Bat} related diagnosis bus. It also includes a separate comparator L which is also able to be linked to the V_{Bat} bus. The input TX and output RX of K are related to V_{CC} with her integrated pull up resistances. Also the L comparator output LO has a pull up resistance connected to V_{CC} .

All V_{Bat} bus defined inputs LI and K have supply voltage dependent thresholds together with sufficient hysteresis to suppress line spikes. These pins are protected against overvoltages, shorts to GND and VS and can also be driven beyond VS and GND. These features are also given for TX, RX and LI only taking into account the behaviour of the internal pull up resistances. The thermal shut down function switches OFF the K output if the chip temperature increases above the thermal shut down threshold. To reactivate K again the chip temperature must decrease below the K switch ON temp. To achieve no fault for VS undervoltage conditions the outputs will be switched OFF and stay at high impedance. The device is also protected against reverse battery condition. During lack of VS or GND all pins shows high impedance characteristic. To realize a lack of the VS related bus line LI and K the outputs LO and RX shows defined ON status. Suppressing all 4 classes of "Schaffner" signals (Schaffner 1; 2; 3a,b; 4) all pins can be load with short energy pulses of max. $\pm 0.2mJ$. All these features together with a high possible baud rate $> 130Kbaud$, controlled output slopes for low EMI, a wide power supply voltage range and a real standby function with zero power consumption $I_{dSB typ} \leq 1\mu A$ during system depowering $V_{CC} \leq 0.5V$ make this device high efficient for automotive bus system.

After wake up of the system from SB condition the first output signal will have an additional delay time $t_{dtyp} \leq 5\mu s$.

The typical output voltage behaviour for the K, LO, RX outputs as a function of the output current is shown in Fig.5. Fig.6 shows a waveform of the output signal when the low level changes from $R_{ON} \cdot I_{OUT}$ to $I_{OUT} \cdot 2 \cdot R_{ON} + U_{BE}$ state. This variation occurs due to too low output current or after a negative transient forced to the output or to the supply voltage line.

Figure 1. Input to output timings and output pulse shape

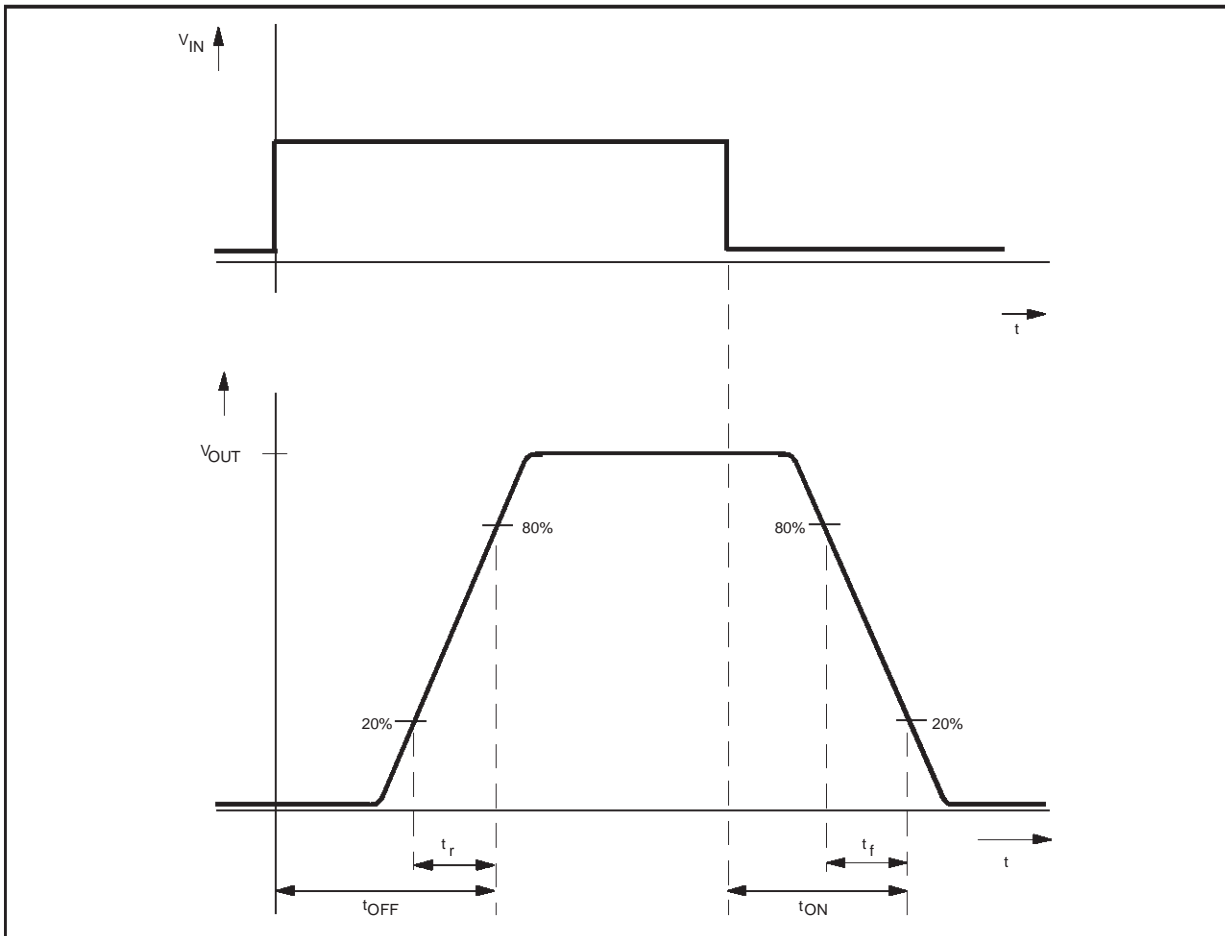

Figure 2. Standby reaction time.

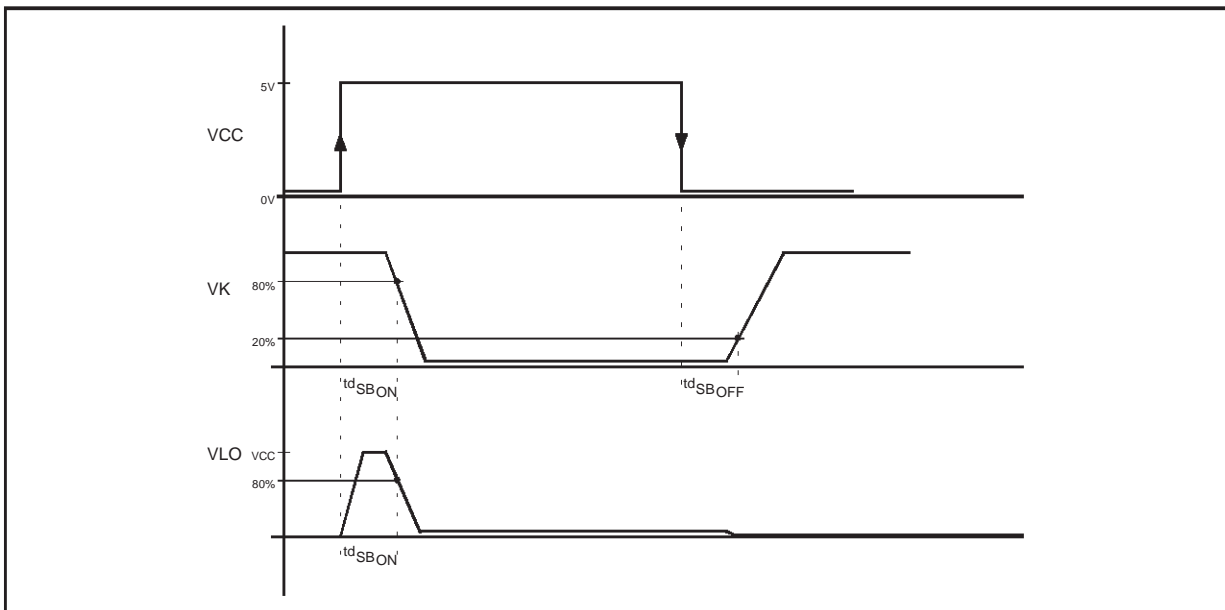

Figure 3. Output characteristics at K, LO, RX.

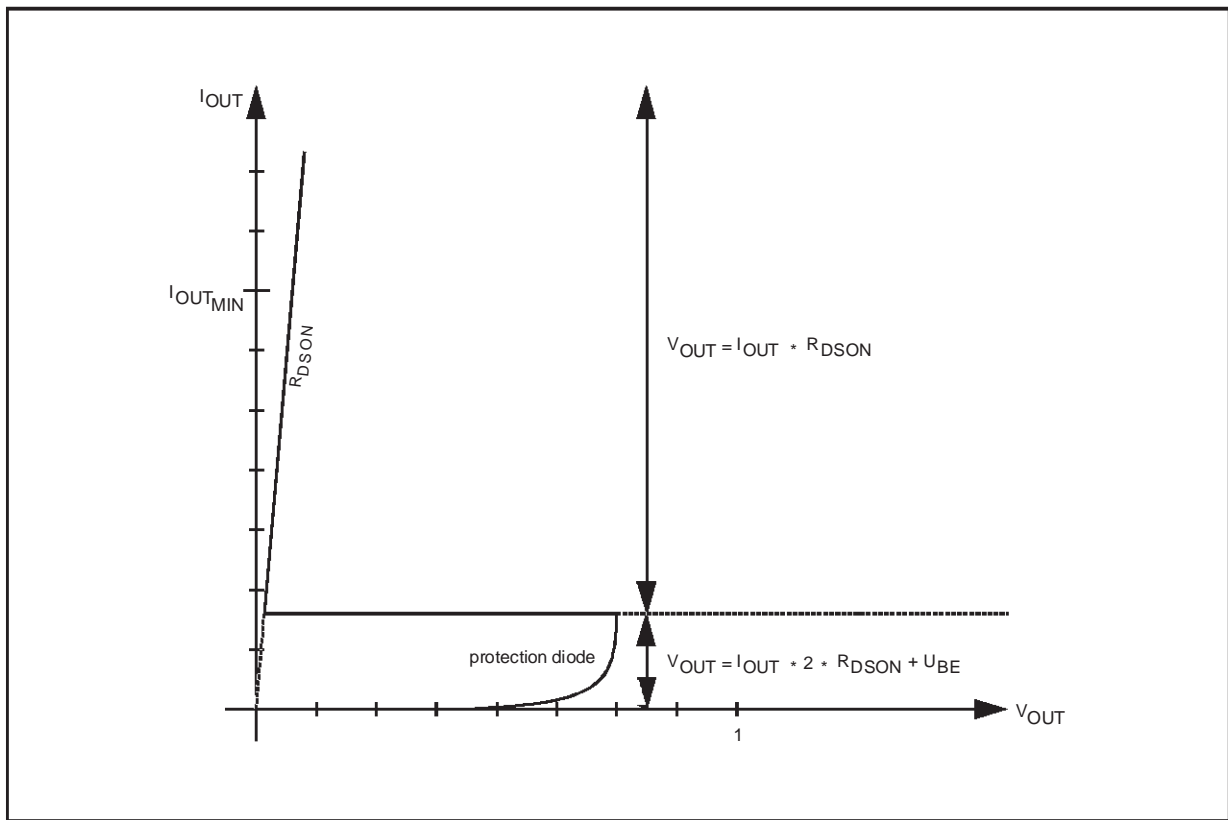

Figure 4. Output signal shape related to output current.

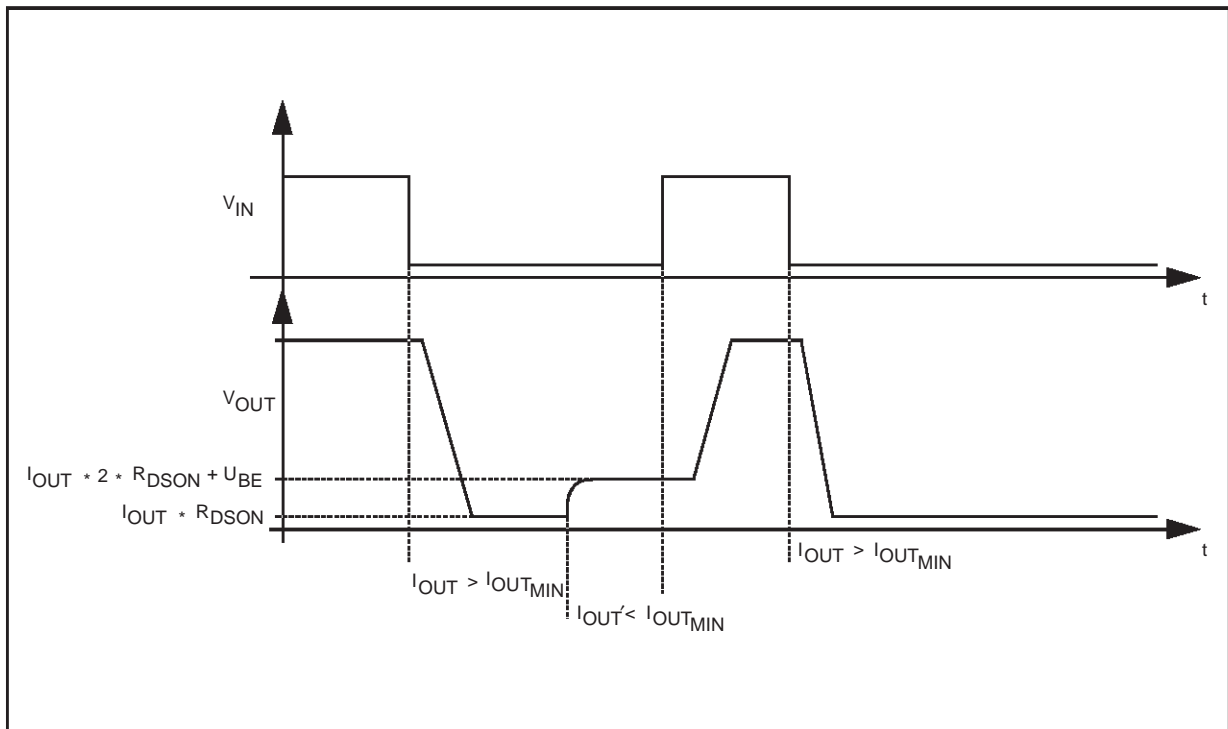

Figure 5. Standby current consumption.

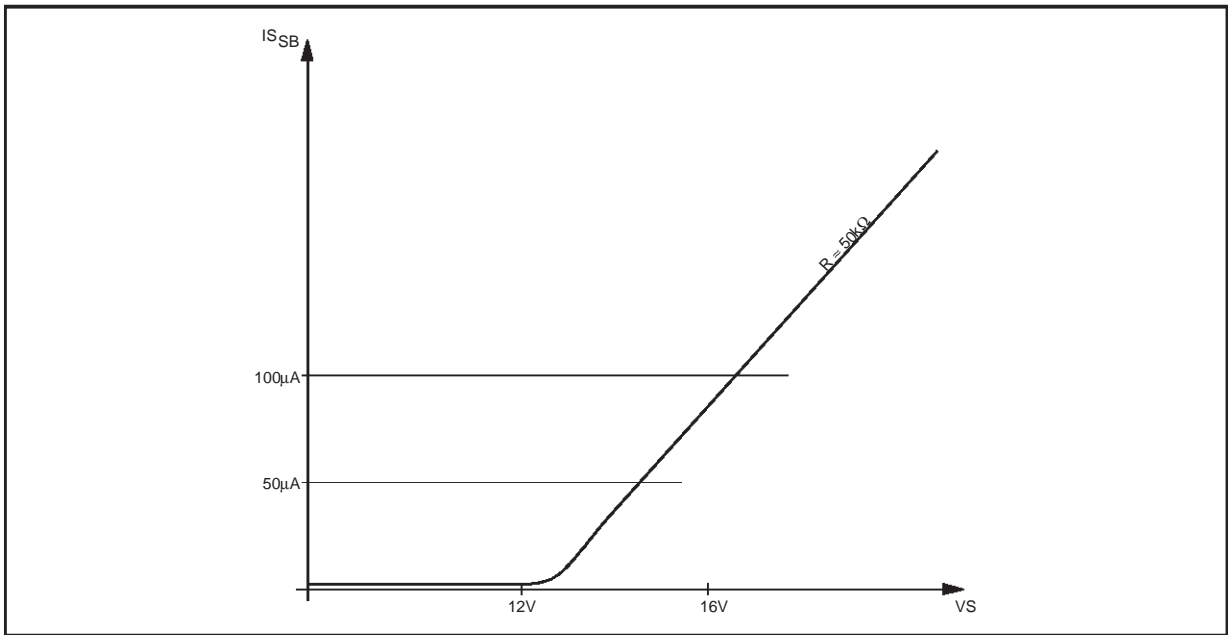
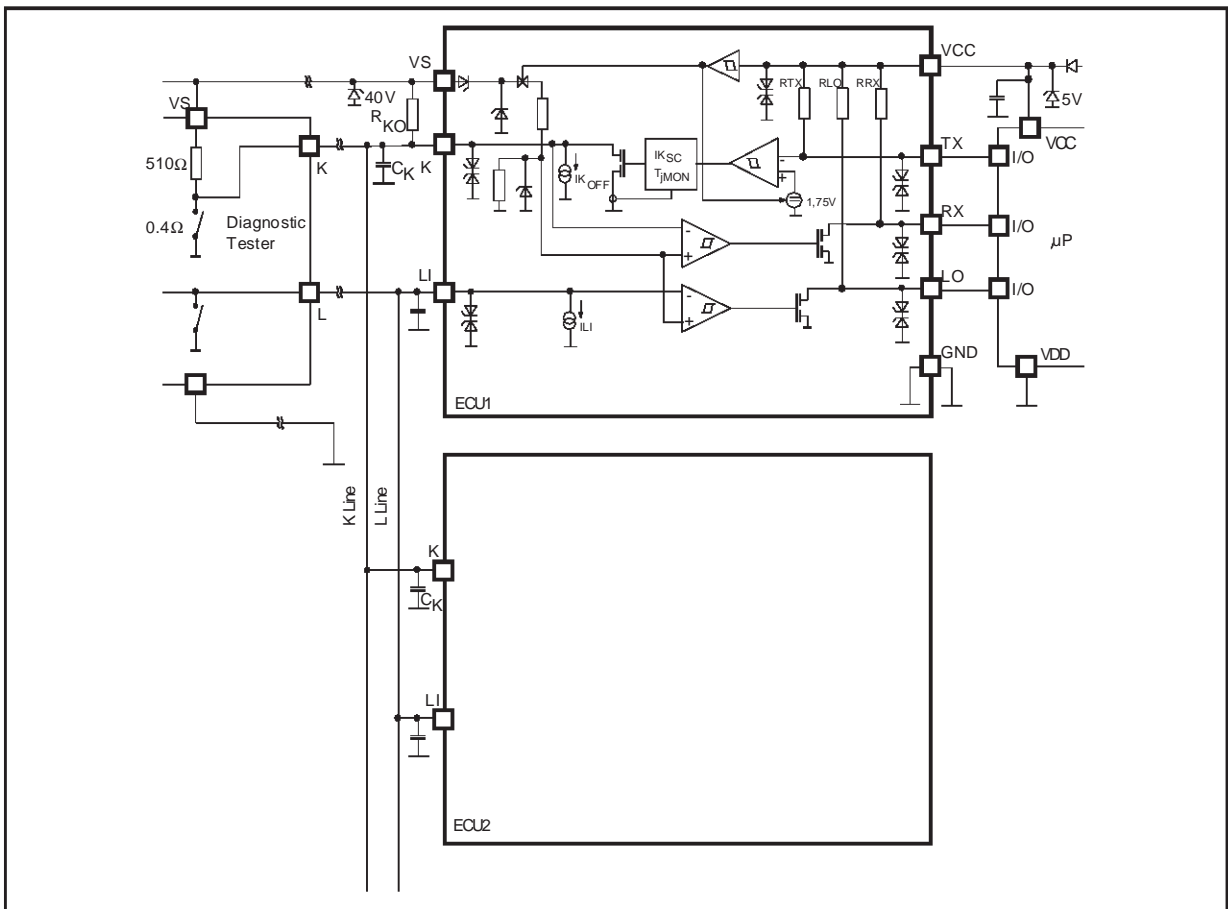

Figure 6. Application Circuit.



EMS Performance (ISO 9141 BUS system)

Figure 7.

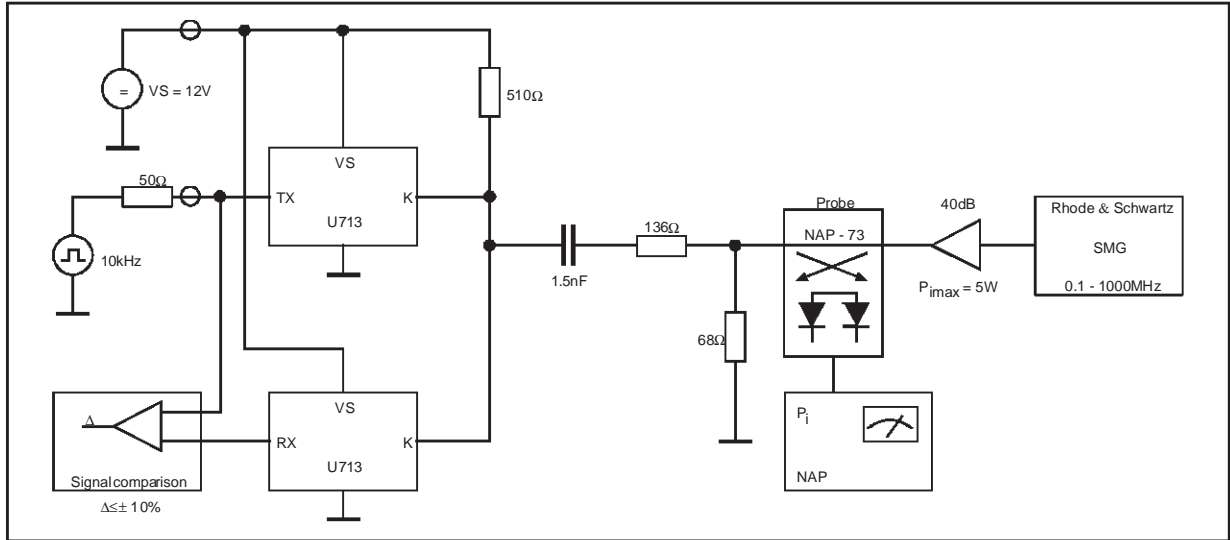
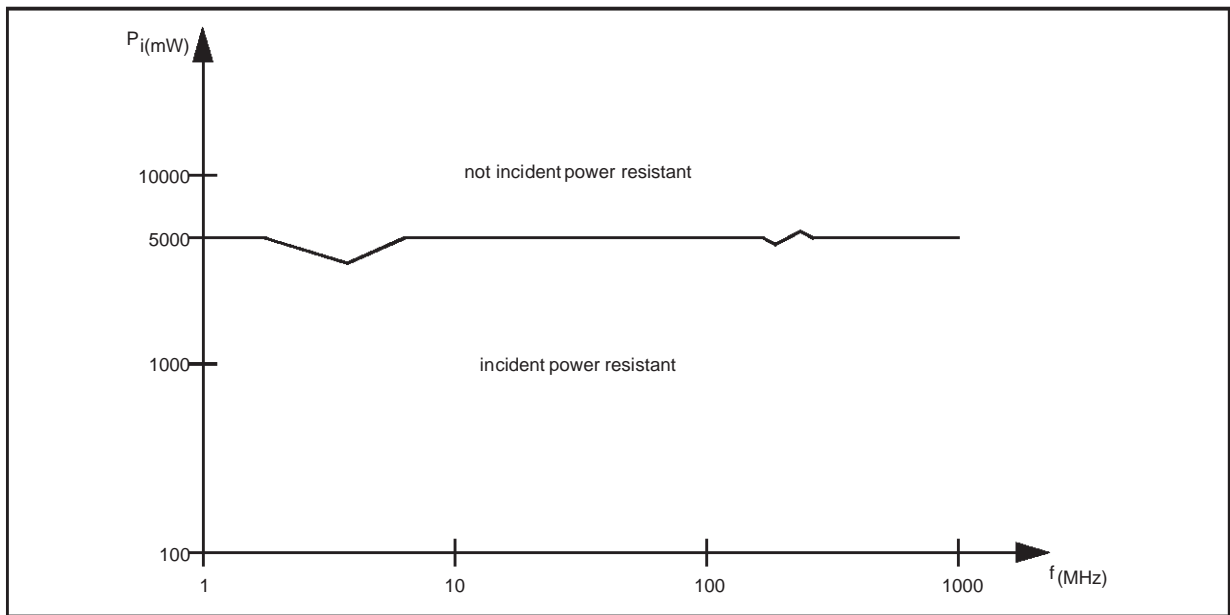

Figure 8.



ESD application hints

To improve the ESD robustness of this device above specified $\pm 2\text{KV}/\text{HBM}$ external blocking capacitors must be used. Nevertheless the max. energy which can be clamped by this device should not exceeds 0.2mJ for each pin. An equivalent input diagram for calculation can be seen in fig. 9.

ESD discharge model

$$E_{\text{ESD}} = \frac{1}{2} C_{\text{HBM}} U_{\text{ESD}}^2 = 0.2\text{mJ} + \frac{1}{2} C_{\text{EXT}} \cdot (45\text{V})^2$$

Figure 9.

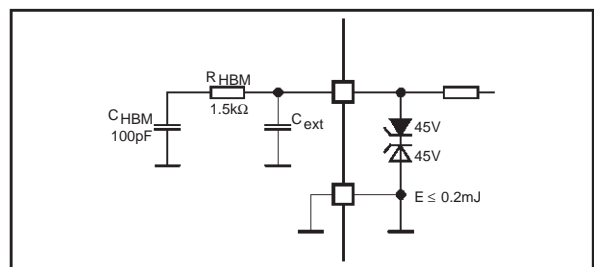

DIM.	mm			inch		
	MIN.	TYP.	MAX.	MIN.	TYP.	MAX.
A			1.75			0.069
a1	0.1		0.25	0.004		0.010
a2			1.65			0.065
a3	0.65		0.85	0.026		0.033
b	0.35		0.48	0.014		0.019
b1	0.19		0.25	0.007		0.010
C	0.25		0.5	0.010		0.020
c1	45° (typ.)					
D (1)	4.8		5.0	0.189		0.197
E	5.8		6.2	0.228		0.244
e		1.27			0.050	
e3		3.81			0.150	
F (1)	3.8		4.0	0.15		0.157
L	0.4		1.27	0.016		0.050
M			0.6			0.024
S	8° (max.)					

OUTLINE AND MECHANICAL DATA

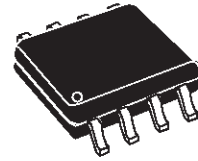

SO8

(1) D and F do not include mold flash or protrusions. Mold flash or protrusions shall not exceed 0.15mm (.006inch).

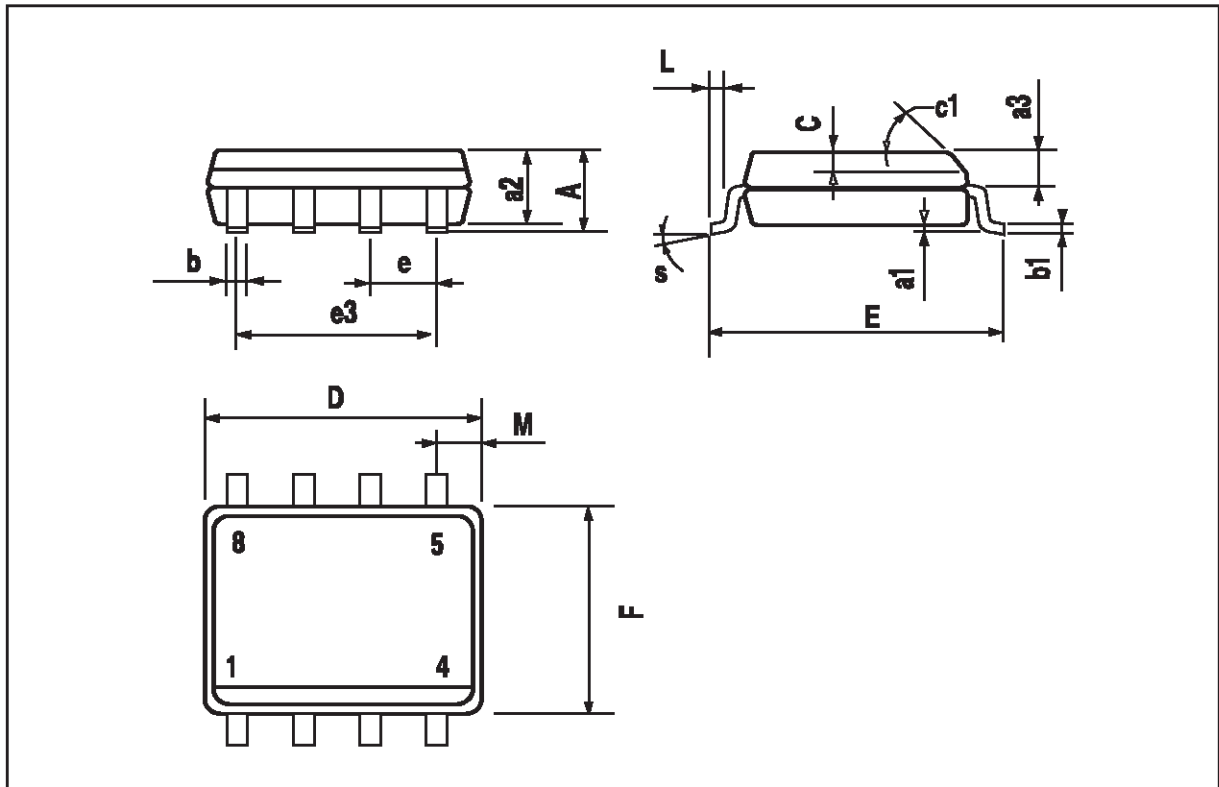

Information furnished is believed to be accurate and reliable. However, STMicroelectronics assumes no responsibility for the consequences of use of such information nor for any infringement of patents or other rights of third parties which may result from its use. No license is granted by implication or otherwise under any patent or patent rights of STMicroelectronics. Specification mentioned in this publication are subject to change without notice. This publication supersedes and replaces all information previously supplied. STMicroelectronics products are not authorized for use as critical components in life support devices or systems without express written approval of STMicroelectronics.

The ST logo is a registered trademark of STMicroelectronics

© 1999 STMicroelectronics – Printed in Italy – All Rights Reserved

STMicroelectronics GROUP OF COMPANIES

Australia - Brazil - China - Finland - France - Germany - Hong Kong - India - Italy - Japan - Malaysia - Malta - Morocco -
Singapore - Spain - Sweden - Switzerland - United Kingdom - U.S.A.