

High-voltage high and low side driver

Features

- High voltage rail up to 600V
- dV/dt immunity $\pm 50V/nsec$ in full temperature range
- Driver current capability:
 - 400mA source,
 - 650mA sink
- Switching times 50/30 nsec rise/fall with 1nF load
- CMOS/TTL Schmitt trigger inputs with hysteresis and pull down
- Under voltage lock out on lower and upper driving section
- Integrated bootstrap diode
- Outputs in phase with inputs

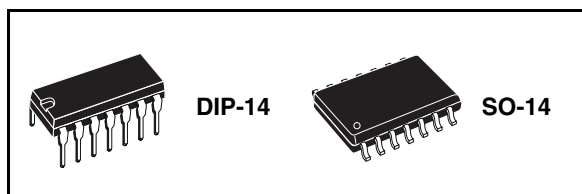

Description

The L6386E is an high-voltage device, manufactured with the BCD "OFF-LINE" technology. It has a Driver structure that enables to drive independent referenced Channel Power MOS or IGBT. The High Side (Floating) Section is enabled to work with voltage Rail up to 600V. The Logic Inputs are CMOS/TTL compatible for ease of interfacing with controlling devices.

Figure 1. Block diagram

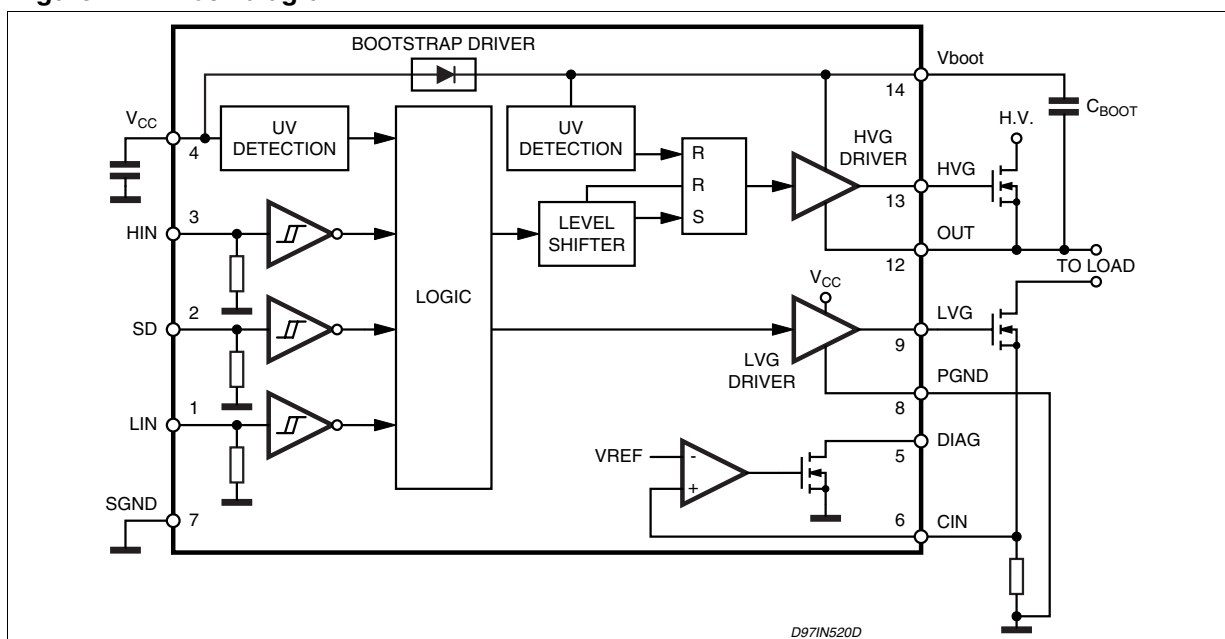

Contents

1	Electrical data	3
1.1	Absolute maximum ratings	3
1.2	Thermal data	3
1.3	Recommended operating conditions	3
2	Pin connection	4
3	Electrical characteristics	5
3.1	AC operation	5
3.2	DC operation	5
3.3	Timing diagram	7
4	Bootstrap driver	8
4.1	C _{BOOT} selection and charging	8
5	Typical characteristic	10
6	Package mechanical data	13
7	Order codes	16
8	Revision history	17

1 Electrical data

1.1 Absolute maximum ratings

Table 1. Absolute maximum ratings

Symbol	Parameter	Value	Unit
V_{out}	Output voltage	-3 to $V_{boot} - 18$	V
V_{cc}	Supply voltage	- 0.3 to +18	V
V_{boot}	Floating supply voltage	-1 to 618	V
V_{hvg}	High side gate output voltage	- 1 to V_{boot}	V
V_{lvg}	Low side gate output voltage	-0.3 to $V_{cc} + 0.3$	V
V_i	Logic input voltage	-0.3 to $V_{cc} + 0.3$	V
V_{diag}	Open drain forced voltage	-0.3 to $V_{cc} + 0.3$	V
V_{cin}	Comparator input voltage	-0.3 to $V_{cc} + 0.3$	V
dV_{out}/dt	Allowed output slew rate	50	V/ns
P_{tot}	Total power dissipation ($T_J = 85\text{ °C}$)	750	mW
T_j	Junction temperature	150	°C
T_{stg}	Storage temperature	-50 to 150	°C

Note: ESD immunity for pins 12, 13 and 14 is guaranteed up to 900V (Human Body Model)

1.2 Thermal data

Table 2. Thermal data

Symbol	Parameter	SO-14	DIP-14	Unit
$R_{th(JA)}$	Thermal Resistance Junction to ambient	165	100	°C/W

1.3 Recommended operating conditions

Table 3. Recommended operating conditions

Symbol	Pin	Parameter	Test condition	Min	Typ	Max	Unit
V_{out}	12	Output voltage		(1)		580	V
$V_{BS}^{(2)}$	14	Floating supply voltage		(1)		17	V
f_{sw}		Switching frequency	HVG,LVG load $C_L = 1nF$			400	kHz
V_{cc}	4	Supply voltage				17	V
T_J		Junction temperature		-45		125	°C

1. If the condition $V_{boot} - V_{out} < 18V$ is guaranteed, V_{out} can range from -3 to 580V

2. $V_{BS} = V_{boot} - V_{out}$

2 Pin connection

Figure 2. Pin connection (Top view)

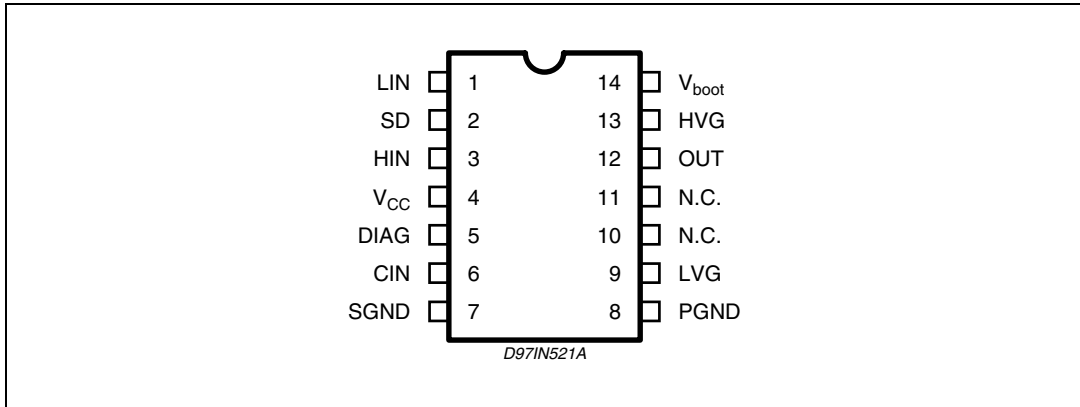

Table 4. Pin description

N°	Pin	Type	Function
1	LIN	I	Low side driver logic input
2	SD ⁽¹⁾	I	Shut down logic input
3	HIN	I	High side driver logic input
4	V _{CC}		Low voltage supply
5	DIAG	O	Open drain diagnostic output
6	CIN	I	Comparator input
7	SGND		Ground
8	PGND		Power ground
9	LVG ⁽¹⁾	O	Low side driver output
10, 11	N.C.		Not connected
12	OUT	O	High side driver floating driver
13	HVG ⁽¹⁾	O	High side driver output
14	V _{boot}		Bootstrapped supply voltage

1. The circuit guarantees 0.3V maximum on the pin (@ I_{sink} = 10mA), with V_{CC} >3V. This allows to omit the "bleeder" resistor connected between the gate and the source of the external MOSFET normally used to hold the pin low; the gate driver assures low impedance also in SD condition.

3 Electrical characteristics

3.1 AC operation

Table 5. AC operation electrical characteristics ($V_{CC} = 15V$; $T_J = 25^\circ C$)

Symbol	Pin	Parameter	Test condition	Min	Typ	Max	Unit
t_{on}	1,3 vs 9,13	High/low side driver turn-on propagation delay	$V_{out} = 0V$		110	150	ns
t_{off}		High/low side driver turn-off propagation delay			110	150	ns
t_{sd}	2 vs 9,13	Shut down to high/low side propagation delay				105	150
t_r	9, 13	Rise time	$C_L = 1000pF$		50		ns
t_f		Fall time	$C_L = 1000pF$		30		ns

3.2 DC operation

Table 6. DC operation electrical characteristics ($V_{CC} = 15V$; $T_J = 25^\circ C$)

Symbol	Pin	Parameter	Test condition	Min	Typ	Max	Unit
Low supply voltage section							
V_{CC}	4	Supply voltage				17	V
V_{ccth1}		V_{CC} UV turn on threshold		11.5	12	12.5	V
V_{ccth2}		V_{CC} UV turn off threshold		9.5	10	10.5	V
V_{cchys}		V_{CC} UV hysteresis			2		V
I_{qccu}		Undervoltage quiescent supply current	$V_{CC} \leq 11V$		200		μA
I_{qcc}		Quiescent current	$V_{CC} = 15V$		250	320	μA
Bootstrapped supply section							
V_{boot}	14	Bootstrap supply voltage				17	V
V_{bth1}		V_{boot} UV turn on threshold		10.7	11.9	12.9	V
V_{bth2}		V_{boot} UV turn off threshold		9.5	9.9	10.7	V
V_{bhys}		V_{boot} UV hysteresis			2		V
I_{qboot}		V_{boot} quiescent current	HVG ON			200	μA
I_{lk}		High voltage leakage current	$V_{hvg} = V_{out} = V_{boot} = 600V$			10	μA
R_{dson}		Bootstrap driver on resistance ⁽¹⁾	$V_{CC} \geq 12.5V$; $V_{in} = 0V$			125	Ω

Table 6. DC operation electrical characteristics (continued)($V_{CC} = 15V$; $T_J = 25^\circ C$)

Symbol	Pin	Parameter	Test condition	Min	Typ	Max	Unit
Driving buffers section							
I_{so}	9, 13	High/low side source short circuit current	$V_{IN} = V_{ih} (t_p < 10\mu s)$	300	400		mA
I_{si}	9, 13	High/low side sink short circuit current	$V_{IN} = V_{il} (t_p < 10\mu s)$	500	650		mA
Logic inputs							
V_{il}	1,2, 3	Low level logic threshold voltage				1.5	V
V_{ih}		High level logic threshold voltage		3.6			V
I_{ih}		High level logic input current	$V_{IN} = 15V$		50	70	μA
I_{il}		Low level logic input current	$V_{IN} = 0V$			1	μA
Sense comparator							
V_{io}		Input offset voltage		-10		10	mV
I_{io}	6	Input bias current	$V_{cin} \geq 0.5$		0.2		μA
V_{ol}	2	Open drain low level output voltage	$I_{od} = -2.5mA$			0.8	V
V_{ref}		Comparator reference voltage		0.46	0.5	0.54	V

1. $R_{DS(on)}$ is tested in the following way:

$$R_{DS(on)} = \frac{(V_{CC} - V_{CBOOT1}) - (V_{CC} - V_{CBOOT2})}{I_1(V_{CC}, V_{CBOOT1}) - I_2(V_{CC}, V_{CBOOT2})}$$

where I_1 is pin 8 current when $V_{CBOOT} = V_{CBOOT1}$, I_2 when $V_{CBOOT} = V_{CBOOT2}$

3.3 Timing diagram

Figure 3. Input/output timing diagram

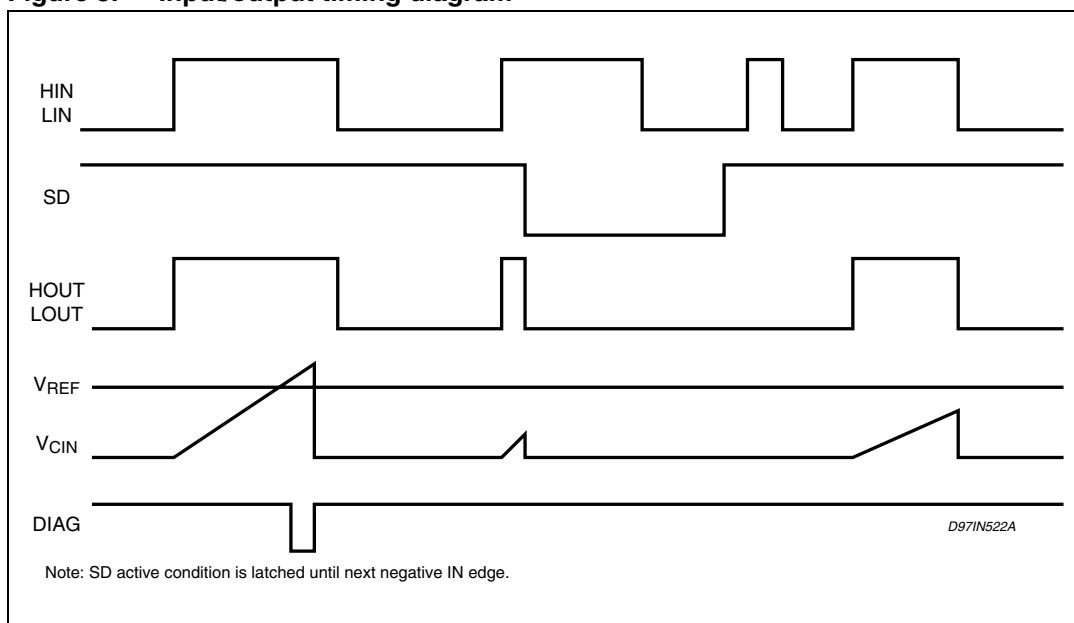

4 Bootstrap driver

A bootstrap circuitry is needed to supply the high voltage section. This function is normally accomplished by a high voltage fast recovery diode (*Figure 4 a*). In the L6386E a patented integrated structure replaces the external diode. It is realized by a high voltage DMOS, driven synchronously with the low side driver (LVG), with in series a diode, as shown in *Figure 4 b*. An internal charge pump (*Figure 4 b*) provides the DMOS driving voltage. The diode connected in series to the DMOS has been added to avoid undesirable turn on of it.

4.1 C_{BOOT} selection and charging

To choose the proper C_{BOOT} value the external MOS can be seen as an equivalent capacitor. This capacitor C_{EXT} is related to the MOS total gate charge:

$$C_{EXT} = \frac{Q_{gate}}{V_{gate}}$$

The ratio between the capacitors C_{EXT} and C_{BOOT} is proportional to the cyclical voltage loss. It has to be:

$$C_{BOOT} \gg C_{EXT}$$

e.g.: if Q_{gate} is 30nC and V_{gate} is 10V, C_{EXT} is 3nF. With C_{BOOT} = 100nF the drop would be 300mV.

If HVG has to be supplied for a long time, the C_{BOOT} selection has to take into account also the leakage losses.

e.g.: HVG steady state consumption is lower than 200µA, so if HVG T_{ON} is 5ms, C_{BOOT} has to supply 1µC to C_{EXT}. This charge on a 1µF capacitor means a voltage drop of 1V.

The internal bootstrap driver gives great advantages: the external fast recovery diode can be avoided (it usually has great leakage current).

This structure can work only if V_{OUT} is close to GND (or lower) and in the meanwhile the LVG is on. The charging time (T_{charge}) of the C_{BOOT} is the time in which both conditions are fulfilled and it has to be long enough to charge the capacitor.

The bootstrap driver introduces a voltage drop due to the DMOS R_{DSON} (typical value: 125 Ω). At low frequency this drop can be neglected. Anyway increasing the frequency it must be taken in to account.

The following equation is useful to compute the drop on the bootstrap DMOS:

$$V_{drop} = I_{charge} R_{dson} \rightarrow V_{drop} = \frac{Q_{gate}}{T_{charge}} R_{dson}$$

where Q_{gate} is the gate charge of the external power MOS, R_{dson} is the on resistance of the bootstrap DMOS, and T_{charge} is the charging time of the bootstrap capacitor.

For example: using a power MOS with a total gate charge of 30nC the drop on the bootstrap DMOS is about 1V, if the T_{charge} is 5μs. In fact:

$$V_{drop} = \frac{30nC}{5\mu s} \cdot 125\Omega \sim 0.8V$$

V_{drop} has to be taken into account when the voltage drop on C_{BOOT} is calculated: if this drop is too high, or the circuit topology doesn't allow a sufficient charging time, an external diode can be used.

Figure 4. Bootstrap driver

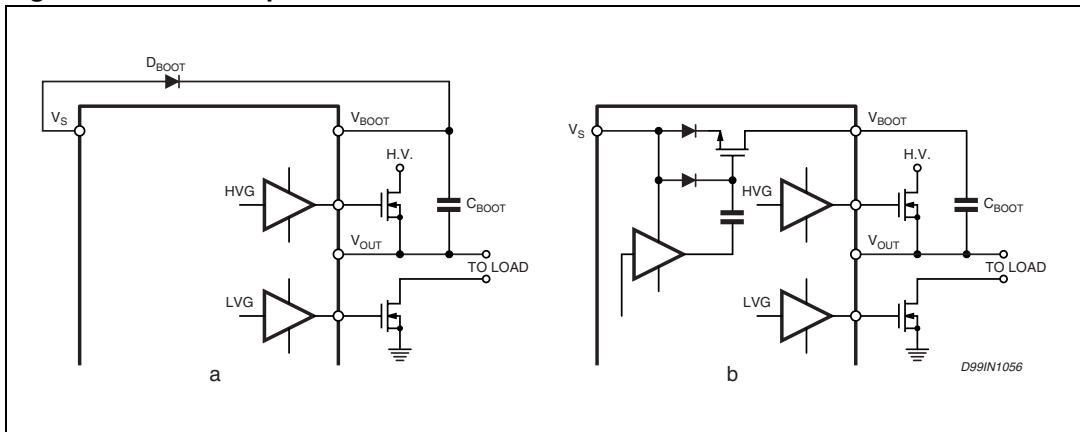

5 Typical characteristic

Figure 5. Typical rise and fall times vs load capacitance

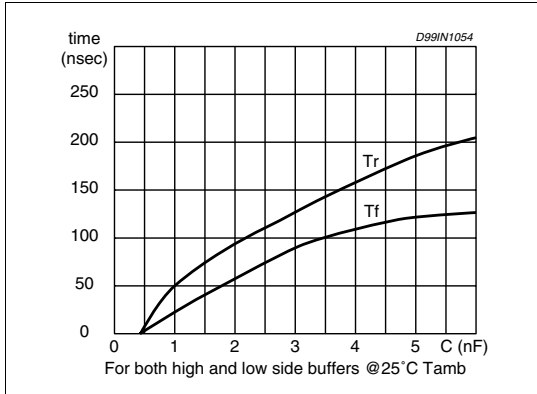

Figure 6. Quiescent current vs supply voltage

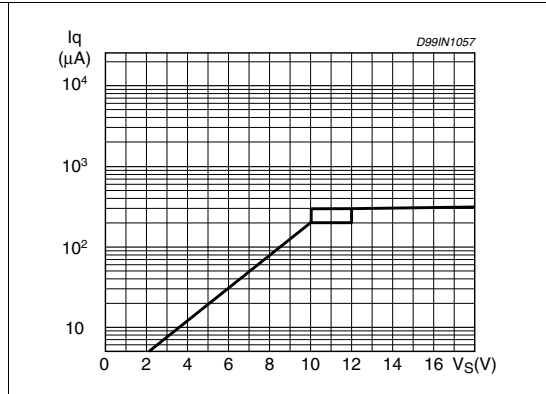

Figure 7. Turn on time vs temperature

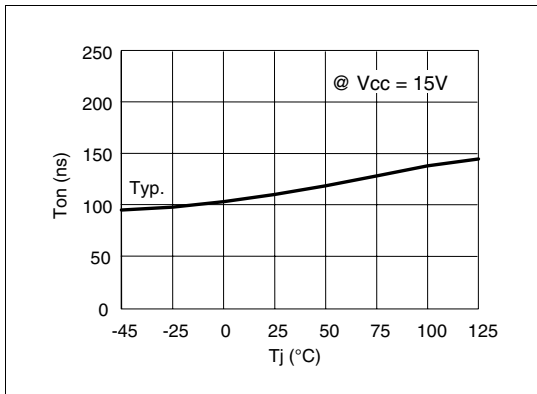

Figure 8. V_BOOT UV turn on threshold vs temperature

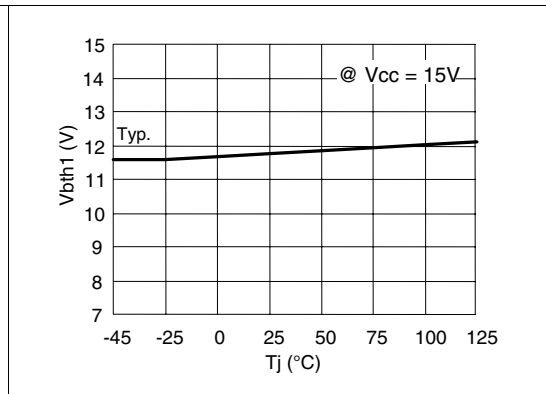

Figure 9. Turn Off time vs temperature

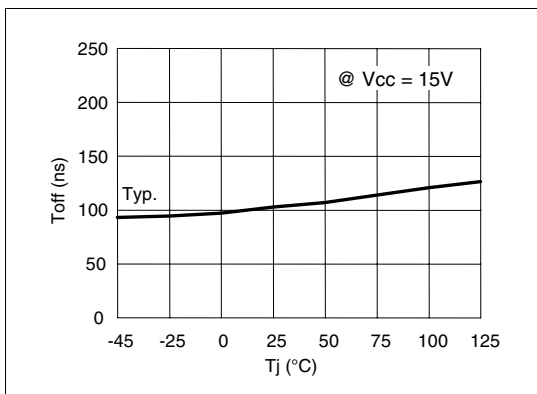

Figure 10. V_BOOT UV turn off threshold vs temperature

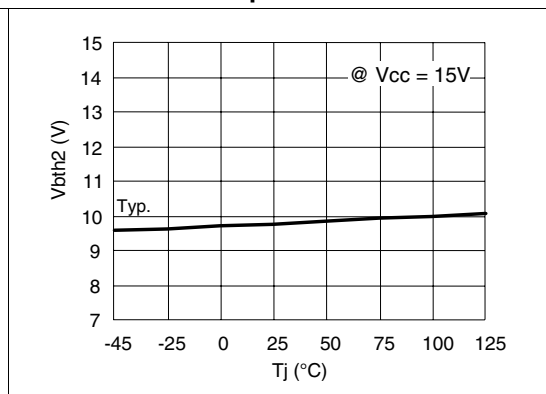

Figure 11. Shutdown time vs temperature

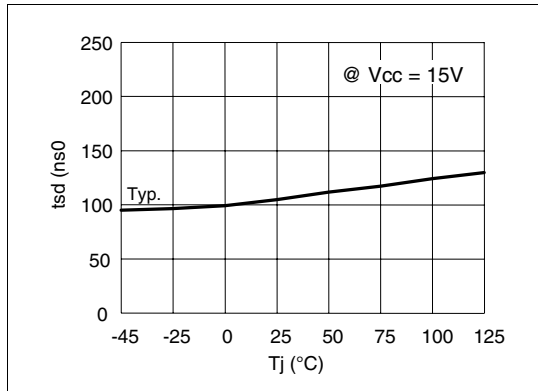

Figure 12. V_{BOOT} UV Hysteresis

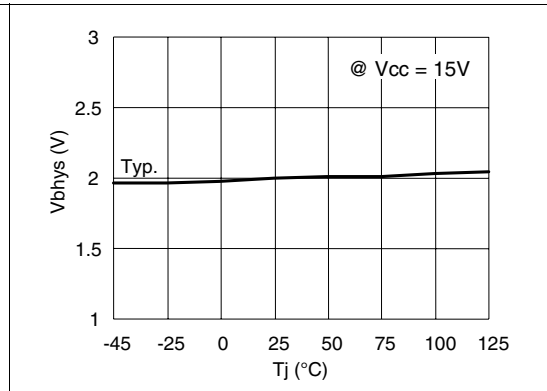

Figure 13. V_{CC} UV turn on threshold vs temperature

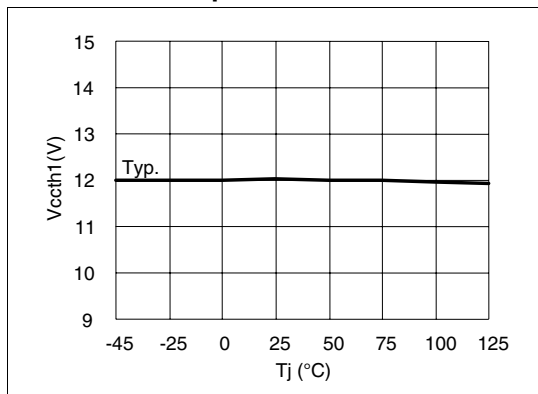

Figure 14. Output source current vs temperature

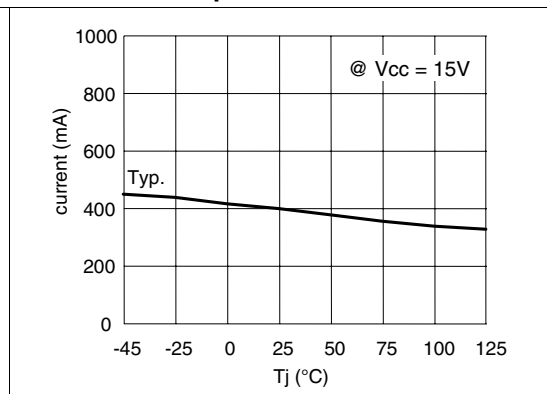

Figure 15. V_{CC} UV turn off threshold vs temperature

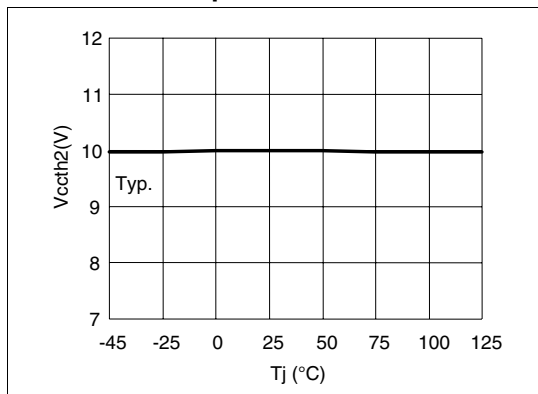

Figure 16. Output sink current vs temperature

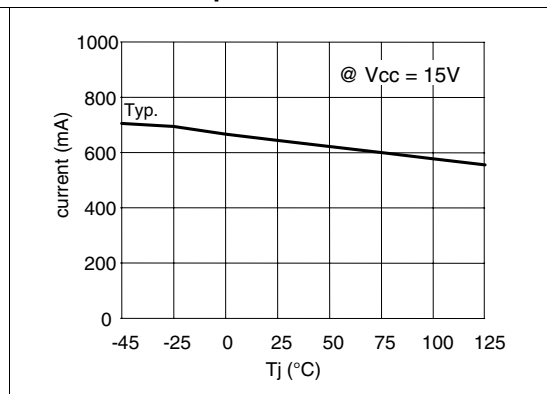
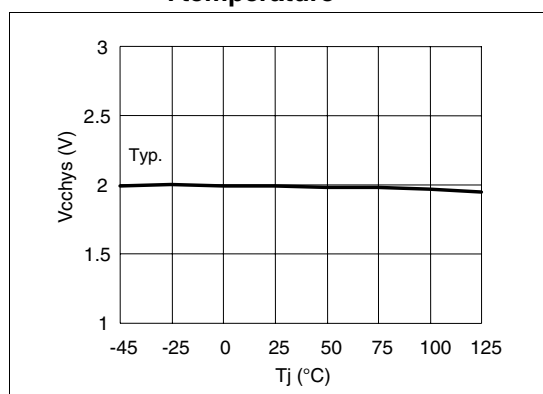

Figure 17. V_{CC} UV hysteresis vs temperature



6 Package mechanical data

In order to meet environmental requirements, ST offers these devices in ECOPACK® packages. These packages have a Lead-free second level interconnect . The category of second level interconnect is marked on the package and on the inner box label, in compliance with JEDEC Standard JESD97. The maximum ratings related to soldering conditions are also marked on the inner box label. ECOPACK is an ST trademark. ECOPACK specifications are available at: www.st.com

Figure 18. DIP-14 mechanical data and package dimensions

DIM.	mm			inch		
	MIN.	TYP.	MAX.	MIN.	TYP.	MAX.
a1	0.51			0.020		
B	1.39		1.65	0.055		0.065
b		0.5			0.020	
b1		0.25			0.010	
D			20			0.787
E		8.5			0.335	
e		2.54			0.100	
e3		15.24			0.600	
F			7.1			0.280
I			5.1			0.201
L		3.3			0.130	
Z	1.27		2.54	0.050		0.100

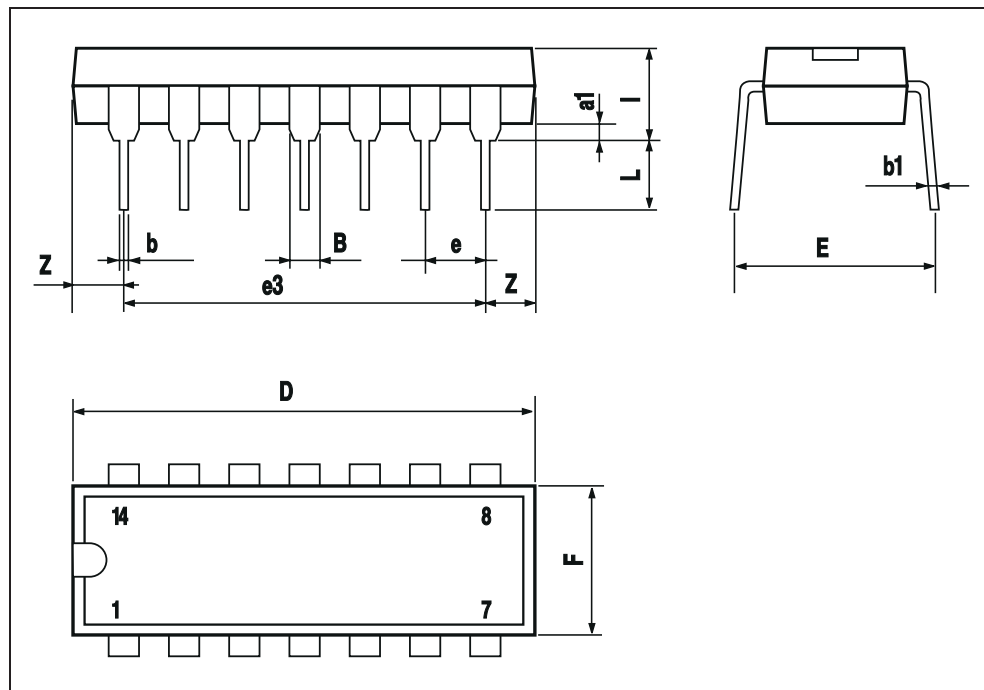
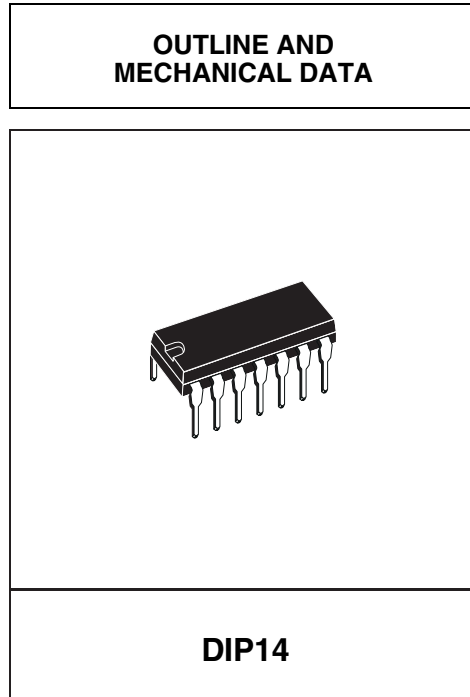
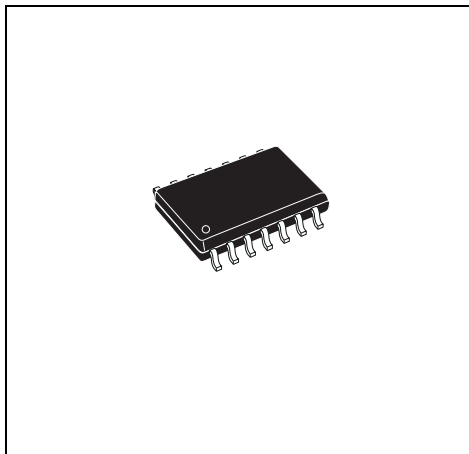

Figure 19. SO-14 mechanical data and package dimensions

DIM.	mm			inch		
	MIN.	TYP.	MAX.	MIN.	TYP.	MAX.
A	1.35		1.75	0.053		0.069
A1	0.10		0.30	0.004		0.012
A2	1.10		1.65	0.043		0.065
B	0.33		0.51	0.013		0.020
C	0.19		0.25	0.007		0.01
D ⁽¹⁾	8.55		8.75	0.337		0.344
E	3.80		4.0	0.150		0.157
e		1.27			0.050	
H	5.8		6.20	0.228		0.244
h	0.25		0.50	0.01		0.02
L	0.40		1.27	0.016		0.050
k	0° (min.), 8° (max.)					
ddd			0.10			0.004

(1) "D" dimension does not include mold flash, protusions or gate burrs. Mold flash, protusions or gate burrs shall not exceed 0.15mm per side.

OUTLINE AND MECHANICAL DATA



SO14

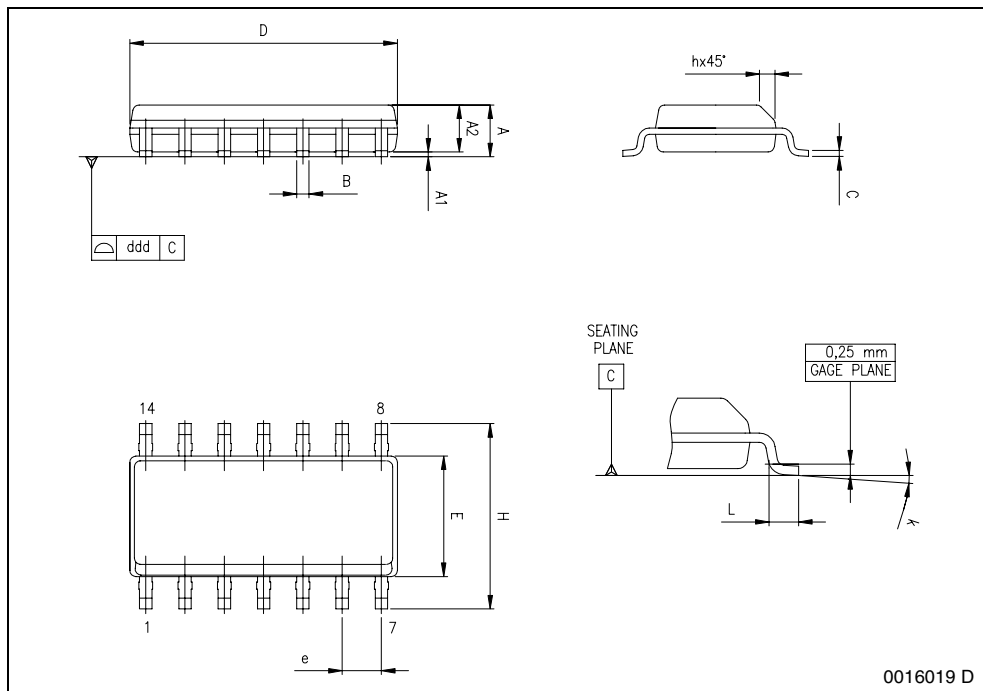

7 Order codes

Table 7. Order codes

Part number	Package	Packaging
L6386E	DIP-8	Tube
L6386ED	SO-8	Tube
L6386ED013TR	SO-8	Tape and reel

8 Revision history

Table 8. Document revision history

Date	Revision	Changes
11-Oct-2007	1	First release

Please Read Carefully:

Information in this document is provided solely in connection with ST products. STMicroelectronics NV and its subsidiaries ("ST") reserve the right to make changes, corrections, modifications or improvements, to this document, and the products and services described herein at any time, without notice.

All ST products are sold pursuant to ST's terms and conditions of sale.

Purchasers are solely responsible for the choice, selection and use of the ST products and services described herein, and ST assumes no liability whatsoever relating to the choice, selection or use of the ST products and services described herein.

No license, express or implied, by estoppel or otherwise, to any intellectual property rights is granted under this document. If any part of this document refers to any third party products or services it shall not be deemed a license grant by ST for the use of such third party products or services, or any intellectual property contained therein or considered as a warranty covering the use in any manner whatsoever of such third party products or services or any intellectual property contained therein.

UNLESS OTHERWISE SET FORTH IN ST'S TERMS AND CONDITIONS OF SALE ST DISCLAIMS ANY EXPRESS OR IMPLIED WARRANTY WITH RESPECT TO THE USE AND/OR SALE OF ST PRODUCTS INCLUDING WITHOUT LIMITATION IMPLIED WARRANTIES OF MERCHANTABILITY, FITNESS FOR A PARTICULAR PURPOSE (AND THEIR EQUIVALENTS UNDER THE LAWS OF ANY JURISDICTION), OR INFRINGEMENT OF ANY PATENT, COPYRIGHT OR OTHER INTELLECTUAL PROPERTY RIGHT.

UNLESS EXPRESSLY APPROVED IN WRITING BY AN AUTHORIZED ST REPRESENTATIVE, ST PRODUCTS ARE NOT RECOMMENDED, AUTHORIZED OR WARRANTED FOR USE IN MILITARY, AIR CRAFT, SPACE, LIFE SAVING, OR LIFE SUSTAINING APPLICATIONS, NOR IN PRODUCTS OR SYSTEMS WHERE FAILURE OR MALFUNCTION MAY RESULT IN PERSONAL INJURY, DEATH, OR SEVERE PROPERTY OR ENVIRONMENTAL DAMAGE. ST PRODUCTS WHICH ARE NOT SPECIFIED AS "AUTOMOTIVE GRADE" MAY ONLY BE USED IN AUTOMOTIVE APPLICATIONS AT USER'S OWN RISK.

Resale of ST products with provisions different from the statements and/or technical features set forth in this document shall immediately void any warranty granted by ST for the ST product or service described herein and shall not create or extend in any manner whatsoever, any liability of ST.

ST and the ST logo are trademarks or registered trademarks of ST in various countries.

Information in this document supersedes and replaces all information previously supplied.

The ST logo is a registered trademark of STMicroelectronics. All other names are the property of their respective owners.

© 2007 STMicroelectronics - All rights reserved

STMicroelectronics group of companies

Australia - Belgium - Brazil - Canada - China - Czech Republic - Finland - France - Germany - Hong Kong - India - Israel - Italy - Japan - Malaysia - Malta - Morocco - Singapore - Spain - Sweden - Switzerland - United Kingdom - United States of America

www.st.com