

2.5 A single high-side smart power switch

Datasheet - production data

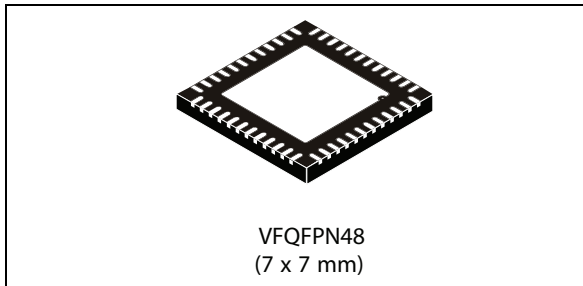

Features

Type	V_{demag}	$R_{\text{DS(on)}}$	I_{out}	V_{S}
L6370Q	$V_{\text{S}} - 50 \text{ V}$	0.1Ω	2.5 A	50 V

- 9.5 V to 35 V supply voltage range
- Internal current limit
- Thermal shutdown
- Open ground protection
- Internal negative voltage clamping for fast demagnetization ($V_{\text{S}} - 50 \text{ V}$)
- Differential inputs with large common mode range and threshold hysteresis
- Undervoltage lockout with hysteresis
- Open load detection

- Two diagnostic outputs
- Output status LED driver
- Non-dissipative short-circuit protection
- Surge and transient protection (IEC61000-4-5)
- Burst transient immunity (IEC61000-4-4)
- ESD protection (human body model $\pm 2 \text{ kV}$)

Applications

- Programmable logic controller
- Industrial PC peripheral input/output
- Numerical control machines
- Drivers for all loads (resistive, capacitive, inductive load)

Description

The L6370Q is a monolithic intelligent power switch in BCDmultipower technology to drive inductive or resistive loads. An internal clamping diode enables the fast demagnetization of inductive loads. Diagnostic for CPU feedback and extensive use of electrical protections make this device extremely rugged and especially suitable for industrial automation applications.

Table 1. Device summary

Part number	Package	Packaging
L6370Q	VFQFPN 7x7x1 48L	Tube
L6370QTR		Tape and reel

Contents

- 1 Block diagram and pin description 3**
 - 1.1 Pin description 4

- 2 Electrical specifications 6**
 - 2.1 Absolute maximum ratings 6
 - 2.2 Thermal data 6
 - 2.3 Electrical characteristics 7
 - 2.4 AC operation 8

- 3 Circuit description 10**
 - 3.1 Diagnostic truth table11
 - 3.2 Input section11
 - 3.3 Diagnostic logic11
 - 3.4 Short-circuit operation 12
 - 3.5 Overtemperature protection (OVT) 12
 - 3.6 Undervoltage protection (UV) 12
 - 3.7 Demagnetization of inductive loads 13

- 4 Package mechanical data 14**

- 5 Revision history 16**

1 Block diagram and pin description

Figure 1. Block diagram

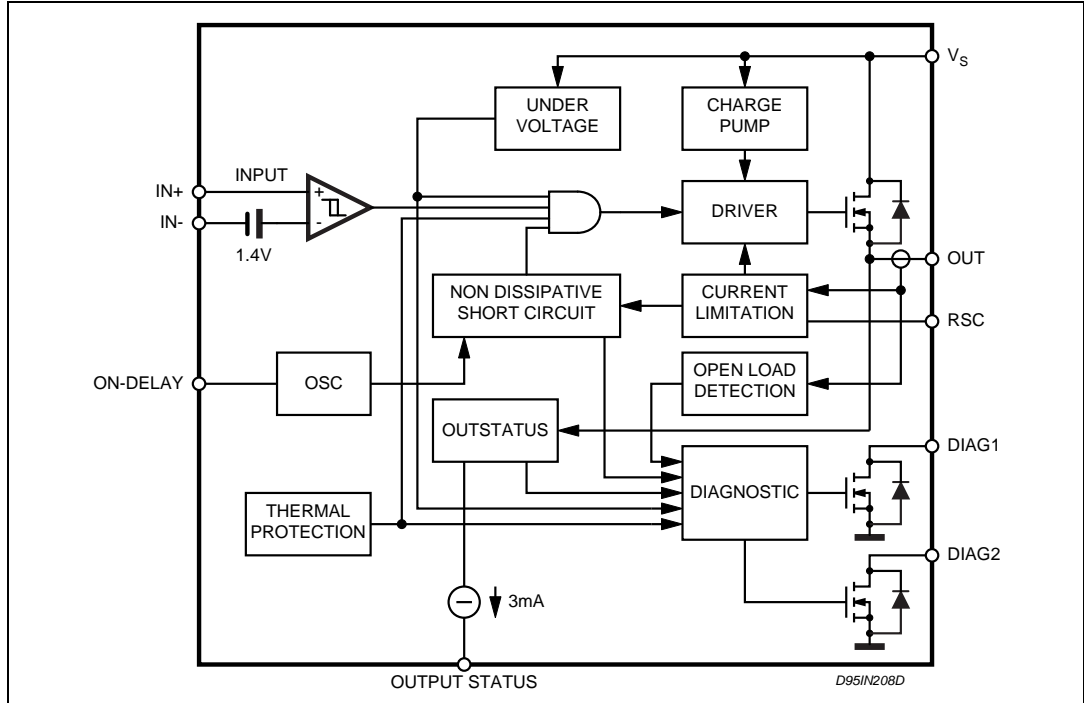
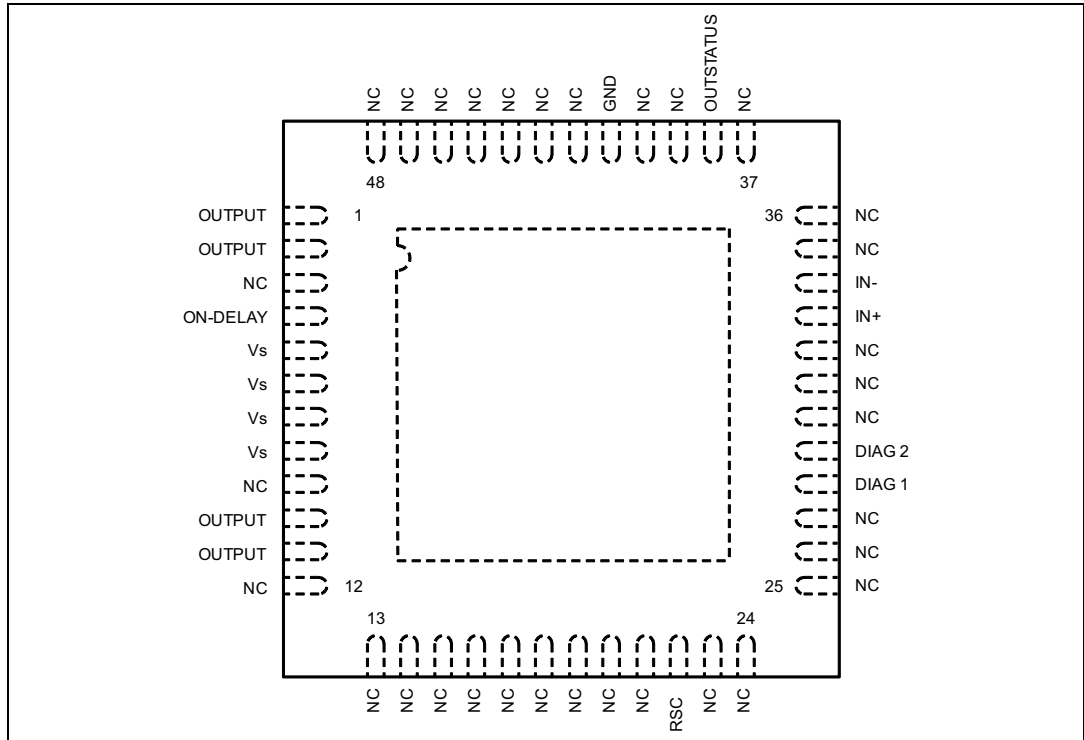

Figure 2. Pin connections (top view)



1.1 Pin description

Table 2. Pin description

Pin	Name	Description
1	OUTPUT	High-side output with built-in current limitation
2	OUTPUT	High-side output with built-in current limitation
3	NC	Not connected
4	ON-DELAY	Programmable on-time interval duration during short-circuit operation
5	Vs	Supply voltage input, the value of the supply voltage is monitored to detect undervoltage conditions
6	Vs	Supply voltage input, the value of the supply voltage is monitored to detect undervoltage conditions
7	Vs	Supply voltage input, the value of the supply voltage is monitored to detect undervoltage conditions
8	Vs	Supply voltage input, the value of the supply voltage is monitored to detect undervoltage conditions
9	NC	Not connected
10	OUTPUT	High-side output with built-in current limitation
11	OUTPUT	High-side output with built-in current limitation
12	NC	Not connected
13	NC	Not connected
14	NC	Not connected
15	NC	Not connected
16	NC	Not connected
17	NC	Not connected
18	NC	Not connected
19	NC	Not connected
20	NC	Not connected
21	NC	Not connected
22	RSC	Current limitation settings
23	NC	Not connected
24	NC	Not connected
25	NC	Not connected
26	NC	Not connected
27	NC	Not connected
28	DIAG1	DIAGNOSTIC1 output. This open drain reports the IC working conditions (see Table 6)

Table 2. Pin description (continued)

Pin	Name	Description
29	DIAG2	DIAGNOSTIC2 output. This open drain reports the IC working conditions (see Table 6)
30	NC	Not connected
31	NC	Not connected
32	NC	Not connected
33	IN+	Comparator inverting input
34	IN-	Comparator non-inverting input
35	NC	Not connected
36	NC	Not connected
37	NC	Not connected
38	OUTSTATUS	This current source output drives a LED to signal the status of the output pin. The pin is active (source current) when the output pin is considered high
39	NC	Not connected
40	NC	Not connected
41	GND	Ground
42	NC	Not connected
43	NC	Not connected
44	NC	Not connected
45	NC	Not connected
46	NC	Not connected
47	NC	Not connected
48	NC	Not connected

2 Electrical specifications

2.1 Absolute maximum ratings

Table 3. Absolute maximum ratings

Symbol	Parameter	Value	Unit
V_s	Supply voltage ($T_w < 10$ ms)	50	V
$V_s - V_o$	Supply to output differential voltage (see also V_{cl})	Internally limited	V
V_{od}	Externally forced voltage	-0.3 to 7	V
I_{od}	Externally forced current	± 1	mA
V_{IN}	Input voltage	-10 to $V_s + 10$	V
V_i	Differential input voltage	43	V
I_{IN}	Input current	20	mA
I_{out}	Output current (see also I_{sc})	Internally limited	A
E_i	Energy inductive load $T_j = 85$ °C	1	J
P_{TOT}	Power dissipation (see also thermal characteristics)	Internally limited	W
T_{op}	Operating temperature range	-40 to +105	°C
T_{STG}	Storage temperature	-55 to 150	°C

2.2 Thermal data

Table 4. Thermal data

Symbol	Description	Value	Unit
$R_{th(JC)}$	Thermal resistance junction-case	Max. 4	°C/W
$R_{th(JA)}$	Thermal resistance junction-ambient ⁽¹⁾	Max. 50	

1. Mounted on a 2-side + vias PCB with a ground dissipating area on the bottom side.

2.3 Electrical characteristics

($V_s = 24\text{ V}$; $T_j = -25\text{ to }+125\text{ }^\circ\text{C}$, unless otherwise specified)

Table 5. Electrical characteristics

Symbol	Parameter	Test conditions	Min.	Typ.	Max.	Unit
V_{smin}	Supply voltage for valid diagnostics	$I_{diag} > 0.5\text{ mA}$; $V_{dg1} = 1.5\text{ V}$	4		35	V
V_s	Supply voltage (operative)		9.5	24	35	V
I_q	Quiescent current $I_{out} = I_{os} = 0$	V_{il} V_{ih}		0.8 3	1.4 4	mA
V_{sth1}	Undervoltage threshold 1	$T_{amb} = 0\text{ to }+85\text{ }^\circ\text{C}$ (see Figure 4)	8.5	9	9.5	V
V_{sth2}	Undervoltage threshold 2		8	8.5	9	V
V_{sth3}	Supply voltage hysteresis		300	500	700	mV
I_{sc}	Short-circuit current	$V_s = 9.5\text{ to }35\text{ V}$; $R_L = 2\ \Omega$ $5\text{ k}\Omega < R_{SC} < 30\text{ k}\Omega$	15/ R_{SC} (k Ω)			A
		$0 < R_{SC} < 5\text{ k}\Omega$	2.6	3.2	4	A
V_{don}	Output voltage drop	$I_{out} = 2.0\text{ A}$, $T_j = 25\text{ }^\circ\text{C}$ $T_j = 125\text{ }^\circ\text{C}$		200 320	280 440	mV
		$I_{out} = 2.5\text{ A}$, $T_j = 25\text{ }^\circ\text{C}$ $T_j = 125\text{ }^\circ\text{C}$		250 400	350 550	mV
I_{oslk}	Output leakage current	$V_i = V_{ij}$; $V_o = 0\text{ V}$			500	μA
V_{ol}	Low-state out voltage	$V_i = V_{ij}$; $R_L = \infty$		0.8	1.5	V
V_{cl}	Internal voltage clamp ($V_s - V_o$)	$I_o = 1\text{ A}$ Single pulsed: $T_p = 300\ \mu\text{s}$	48	53	58	V
I_{old}	Open load detection current	$V_i = V_{ih}$; $T_{amb} = 0\text{ to }+85\text{ }^\circ\text{C}$	1	3	6	mA
V_{id}	Common mode input voltage range (operative)	$V_s = 18\text{ to }35\text{ V}$	-7		15	V
I_{ib}	Input bias current	$V_i = -7\text{ to }15\text{ V}$; $-I_n = 0\text{ V}$	-250		250	μA
V_{ith}	Input threshold voltage	$V + I_n > V - I_n$	0.8	1.4	2	V
V_{iths}	Input threshold hysteresis voltage	$V + I_n > V - I_n$	50		400	mV
R_{id}	Differential input resistance	$0 < +I_n < +16\text{ V}$; $-I_n = 0\text{ V}$ $-7 < +I_n < 0\text{ V}$; $-I_n = 0\text{ V}$		400 150		k Ω
I_{ilk}	Input offset current	$V + I_n = V - I_n$ +li -20 $0\text{ V} < V_i < 5.5\text{ V}$ -li -75		-25	+20	μA
		$-I_n = \text{GND}$ +li +10 $0\text{ V} < V + I_n < 5.5\text{ V}$ -li -250		-125	+50	
		$+I_n = \text{GND}$ +li -100 $0\text{ V} < V - I_n < 5.5\text{ V}$ -li -50		-15		

Table 5. Electrical characteristics (continued)

Symbol	Parameter	Test conditions	Min.	Typ.	Max.	Unit
V_{oth1}	Output status threshold 1 voltage	(See Figure 3)	4.5	5	5.5	V
V_{oth2}	Output status threshold 2 voltage		4	4.5	5.0	V
V_{ohys}	Output status threshold hysteresis		300	500	700	mV
I_{osd}	Output status source current	$V_{out} > V_{oth1}; V_{os} = 2.5\text{ V}$	2		4	mA
V_{osd}	Active output status driver drop voltage	$V_s - V_{os}; I_{os} = 2\text{ mA}$ $T_{amb} = 0\text{ to }+85\text{ °C}$		1.5	3	V
I_{oslk}	Output status driver leakage current	$V_{out} < V_{oth2}; V_{os} = 0\text{ V}$ $V_s = 9.5\text{ to }35\text{ V}$			25	μA
V_{dgl}	Diagnostic drop voltage	D1 / D2 = L; $I_{diag} = 0.5\text{ mA}$ D1 / D2 = L; $I_{diag} = 3\text{ mA}$		40 250		mV
I_{dglk}	Diagnostic leakage current	D1 / D2 = H; $0 < V_{dg} < V_s$ $V_s = 9.5\text{ to }35\text{ V}$			5	μA
Source drain NDMOS diode						
V_{fSD}	Forward on voltage	@ $I_{fSD} = 2.5\text{ A}$		1	1.5	V
I_{fP}	Forward peak current	$t = 10\text{ ms}; d = 20\%$			6	A
t_{rr}	Reverse recovery time	$I_f = 2.5\text{ A}; di/dt = 25\text{ A}/\mu\text{s}$		200		ns
t_{fr}	Forward recovery time			100		ns
Thermal characteristics						
Θ_{lim}	Junction temperature protection		135	150		$^{\circ}\text{C}$
Θ_{th}	Thermal hysteresis			20		$^{\circ}\text{C}$

Note: $V_{il} \leq 0.8\text{ V}, V_{ih} \geq 2\text{ V} @ (V+In > V-In)$

2.4 AC operation

Table 6. AC operation

Symbol	Parameter	Test conditions	Min.	Typ.	Max.	Unit
$t_r - t_f$	Rise or fall time	$V_s = 24\text{ V}; R_l = 70\ \Omega; R_l$ to ground		20		μs
t_d	Delay time			5		μs
dV/dt	Slew rate (rise and fall edge)		0.7	1	1.5	V/ μs
t_{ON}	On-time during short-circuit condition	$50\text{ pF} < C_{ON} < 2\text{ nF}$		1.28		$\mu\text{s}/\text{pF}$

Table 6. AC operation (continued)

Symbol	Parameter	Test conditions	Min.	Typ.	Max.	Unit
t_{OFF}	Off-time during short-circuit condition			64		t_{ON}
f_{max}	Maximum operating frequency			25		kHz

3 Circuit description

Figure 3. Output status hysteresis

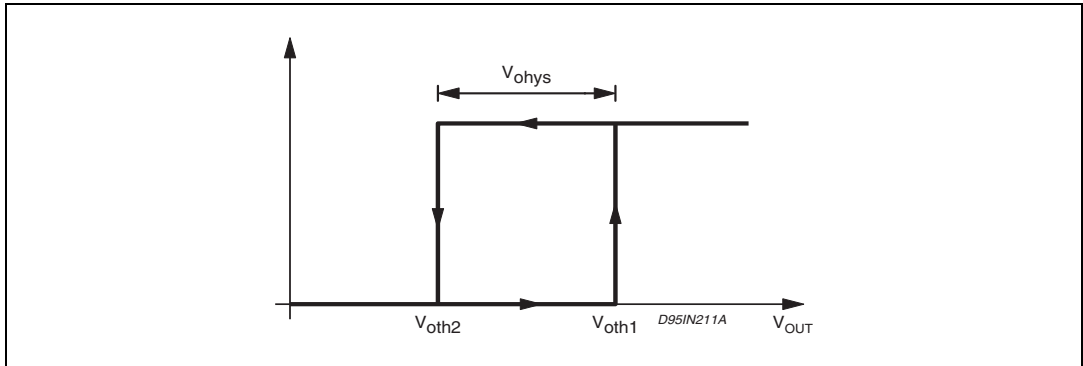

Figure 4. Undervoltage comparator hysteresis

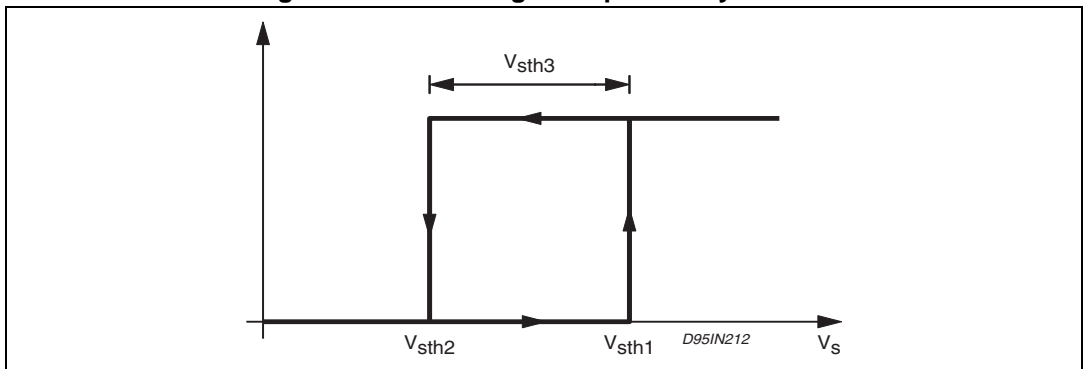
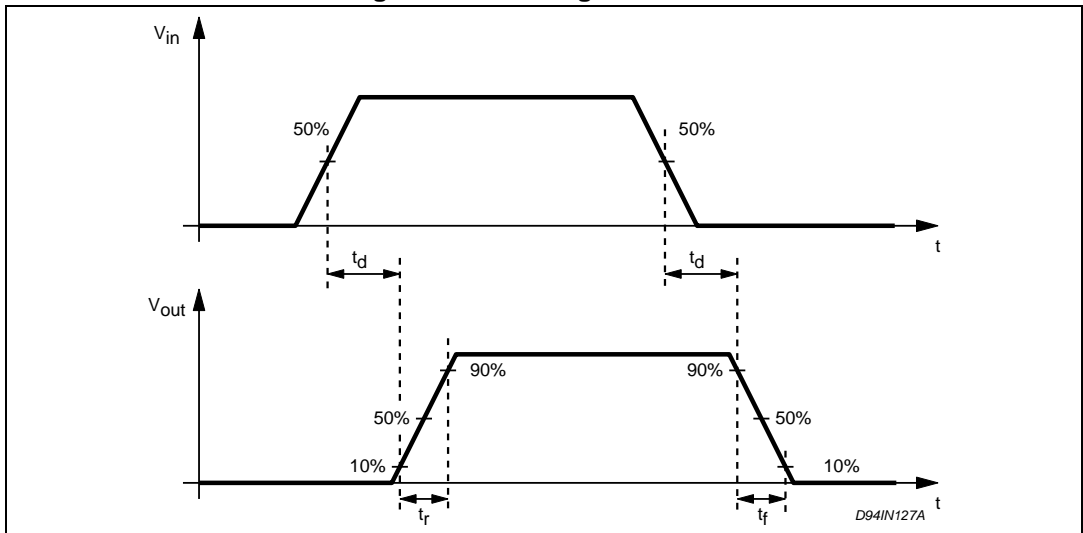

Figure 5. Switching waveforms



3.1 Diagnostic truth table

Table 7. Diagnostic truth table

Diagnostic conditions	Input	Output	Diag1	Diag2
Normal operation	L	L	H	H
	H	H	H	H
Open load condition ($I_o < I_{old}$)	L	L	H	H
	H	H	L	H
Short to V_s	L	H	L	H
	H	H	L	H
Short-circuit to ground ($I_o = I_{SC}$) ⁽¹⁾ (ON-DELAY pin grounded)	H	X	H	H
	L	L	H	H
Output DMOS open	L	L	H	H
	H	L	L	H
Overtemperature	L	L	H	L
	H	L	H	L
Supply undervoltage ($V_s < V_{sth2}$)	L	L	L	L
	H	L	L	L

1. A cold lamp filament, or a capacitive load may activate the current limiting circuit of the IPS, when the IPS is initially turned on.

3.2 Input section

The input section is a high impedance differential stage with high common and differential mode range. Built-in offset of +1.4 V (typical value) and a hysteresis of 400 mV (maximum value) assure high noise immunity.

3.3 Diagnostic logic

The operating conditions of the device are permanently monitored and the following occurrences are indicated by DIAG1/DIAG2 open drain output pins:

- Short-circuit versus ground. A current limit circuit fixes $I_{SC} = 3.2$ A (typical value) the maximum current that can be sourced from the OUTPUT pin (for more details see [Section 3.4: Short-circuit operation](#))
- Short-circuit versus V_s
- Undervoltage (UV)
- Overtemperature (OVT)
- Open load, if the output current is less than 3 mA (typical value)
- Output DMOS open according to [Table 7](#)

3.4 Short-circuit operation

In order to minimize the power dissipation when the output is shorted-to-ground, an innovative, non-dissipative short-circuit protection (patent pending) is implemented, avoiding the thermal protection.

Whenever the output is shorted-to-ground, or, an overcurrent is sinked by the load, the output devices are driven to linear mode, sourcing the I_{sc} current (3.2 A typ.) for a time interval (t_{ON}) defined by the external C_{ON} capacitor connected between the ON-DELAY pin and GND. If the short-circuit increases within the t_{ON} interval the DIAG2 output status is not affected, acting as a programmable diagnostic delay.

This function allows the device to drive a capacitive load or a filament lamp (that exhibits a very low resistance during the initial heading phase) without the diagnostic. If the short-circuit lasts for the whole t_{ON} interval, the output DMOS is switched off and the DIAG2 goes low, for a time interval t_{OFF} lasting t_{ON} 64 times.

At the end of the t_{OFF} interval if the short-circuit condition is still present, the output DMOS is turned on (and the DIAG2 goes high - see [Figure 7](#)) for another t_{ON} interval and the sequence starts again, otherwise, the normal condition operation is resumed.

The t_{ON} interval can be set to last between 64 ms and 2.56 ms for a C_{ON} capacitor value ranging between 50 pF and 2 nF:

Equation 1

$$t_{ON} (\mu s) = 1.28 C_{ON} (pF)$$

If the ON-DELAY pin is grounded, the non-dissipative short-circuit protection is disabled and the I_{sc} current is delivered until the overtemperature protection shuts the device off. The behavior of the DIAG2 output is, in this situation, showed in [Table 7](#).

3.5 Overtemperature protection (OVT)

If the chip temperature exceeds Θ_{lim} (measured in a central position in the chip) the chip deactivates itself.

The following actions are taken:

- the output stage is switched off
- the signal DIAG2 is activated (active low)

Normal operation is resumed as soon as (after some seconds) the chip temperature monitored goes back below $\Theta_{lim} - \Theta_{th}$.

The different thresholds with hysteretic behavior assure that any intermittent condition can be generated.

3.6 Undervoltage protection (UV)

The supply voltage is expected to range from 9.5 V to 35 V, even if its reference value is 24 V.

In this range, the device operates correctly. Below 9.5 V the overall system is not reliable.

Protection shuts off the output whenever the supply voltage falls below the mask fixed by V_{sth1} (9 V typ.) and V_{sth2} (8.5 V typ.).

The hysteresis (see [Figure 4](#)) assures a non-intermittent behavior at low supply voltage with a superimposed ripple. The undervoltage status is indicated by the DIAG1 and DIAG2 outputs (see [Table 7](#)).

3.7 Demagnetization of inductive loads

An internal Zener diode, limiting the voltage across the power MOSFET between 50 and 60 V (V_{cl}), provides safe and fast demagnetization of inductive loads without external clamping devices. The maximum energy that can be absorbed by an inductive load is specified as 1J (at $T_j = 85\text{ }^\circ\text{C}$) (see [Table 3](#)).

Figure 6. L6370Q short-circuit operation waveforms

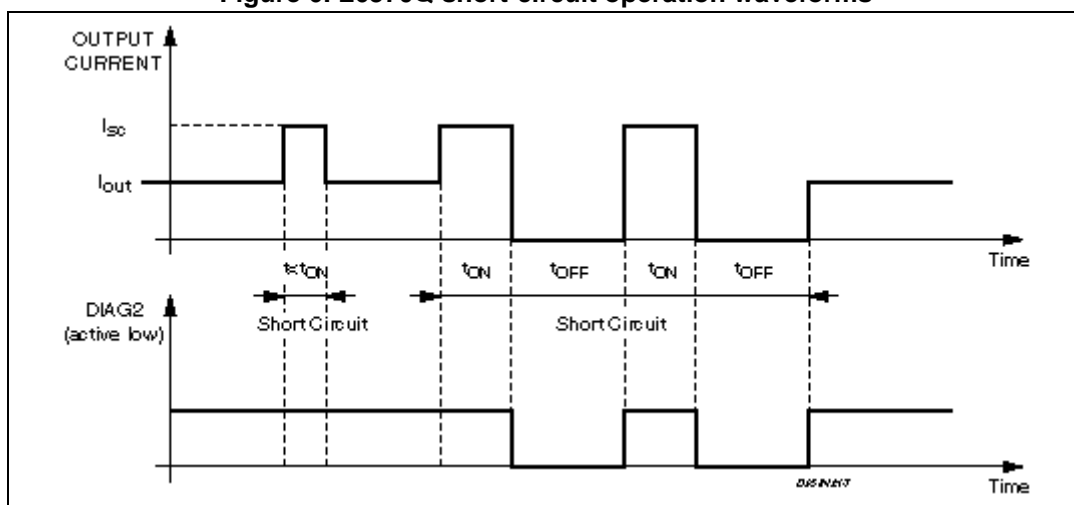
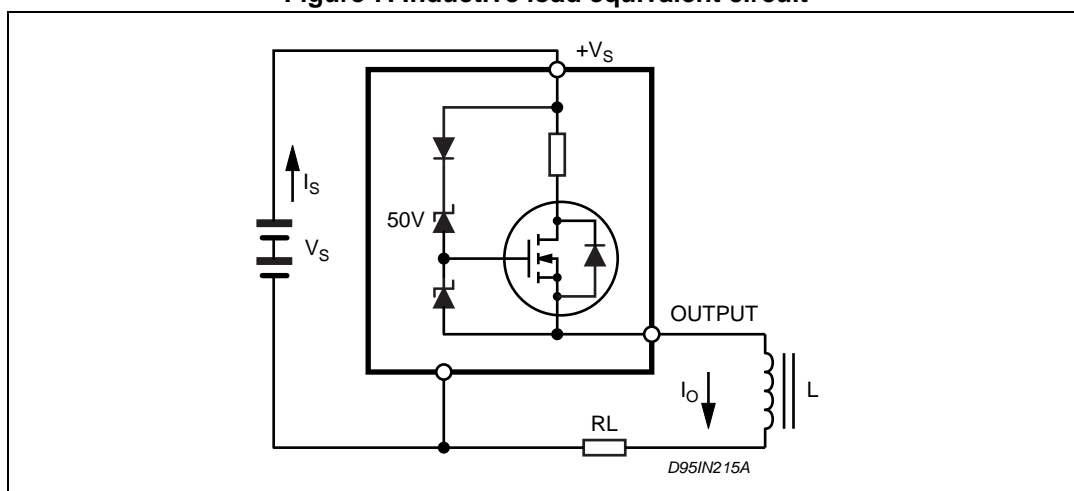

Figure 7. Inductive load equivalent circuit



4 Package mechanical data

In order to meet environmental requirements, ST offers these devices in different grades of ECOPACK® packages, depending on their level of environmental compliance. ECOPACK® specifications, grade definitions and product status are available at: www.st.com. ECOPACK® is an ST trademark.

Figure 8. VFQFPN48 (7 x 7 x 1.0 mm) package mechanical drawings

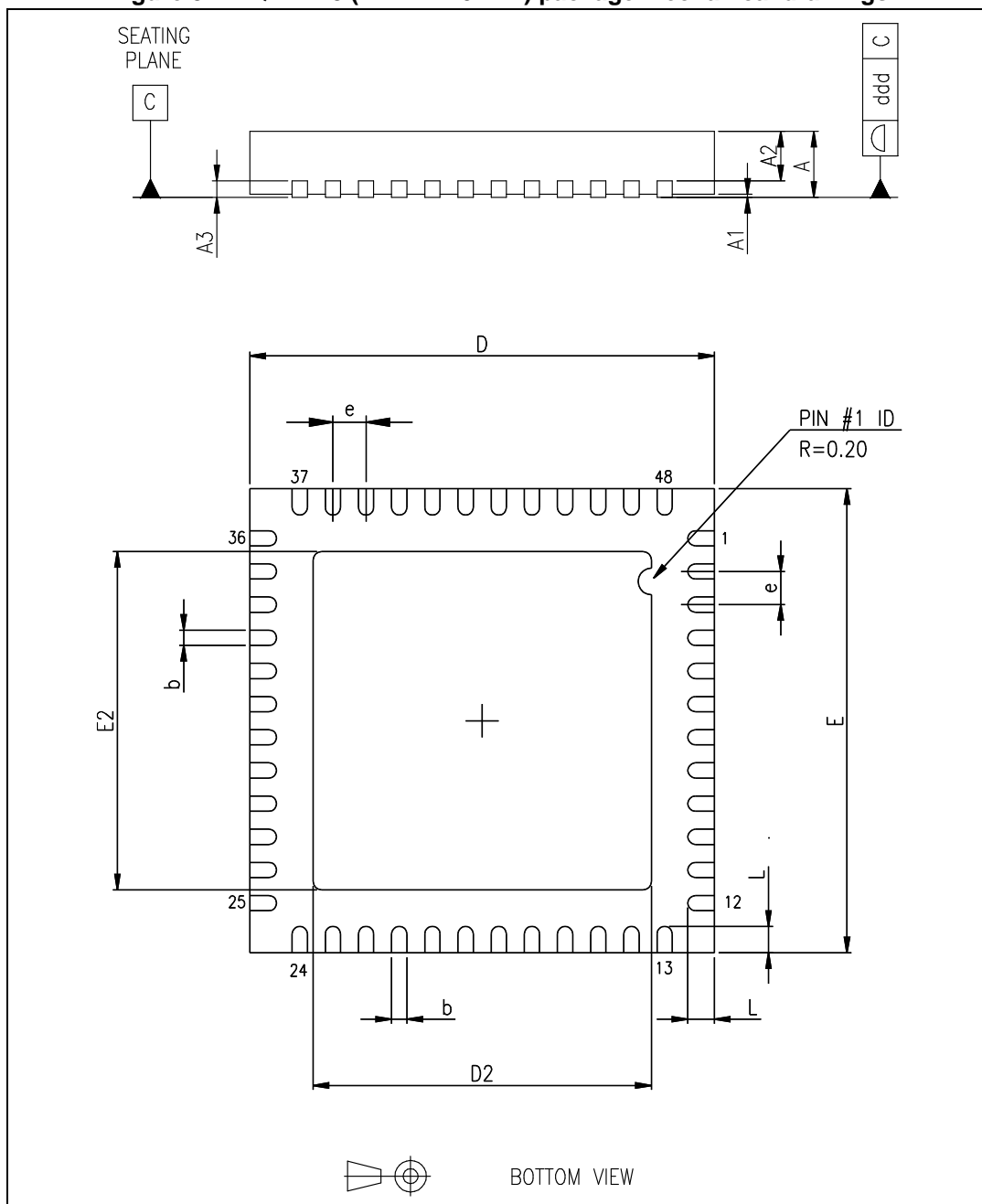

Table 8. VFQFPN48 (7 x 7 x 1.0 mm) package mechanical data

Dim.	(mm)		
	Min.	Typ.	Max.
A	0.80	0.90	1.00
A1		0.02	0.05
A2		0.65	1.00
A3		0.25	
b	0.18	0.23	0.30
D	6.85	7.00	7.15
D2	4.95	5.10	5.25
E	6.85	7.00	7.15
E2	4.95	5.10	5.25
e	0.45	0.50	0.55
L	0.30	0.40	0.50
ddd		0.08	

5 Revision history

Table 9. Document revision history

Date	Revision	Changes
04-Oct-2011	1	Initial release.
24-Jan-2013	2	Changed the operating temperature range parameter in Table 3 . Minor text changes.

Please Read Carefully:

Information in this document is provided solely in connection with ST products. STMicroelectronics NV and its subsidiaries ("ST") reserve the right to make changes, corrections, modifications or improvements, to this document, and the products and services described herein at any time, without notice.

All ST products are sold pursuant to ST's terms and conditions of sale.

Purchasers are solely responsible for the choice, selection and use of the ST products and services described herein, and ST assumes no liability whatsoever relating to the choice, selection or use of the ST products and services described herein.

No license, express or implied, by estoppel or otherwise, to any intellectual property rights is granted under this document. If any part of this document refers to any third party products or services it shall not be deemed a license grant by ST for the use of such third party products or services, or any intellectual property contained therein or considered as a warranty covering the use in any manner whatsoever of such third party products or services or any intellectual property contained therein.

UNLESS OTHERWISE SET FORTH IN ST'S TERMS AND CONDITIONS OF SALE ST DISCLAIMS ANY EXPRESS OR IMPLIED WARRANTY WITH RESPECT TO THE USE AND/OR SALE OF ST PRODUCTS INCLUDING WITHOUT LIMITATION IMPLIED WARRANTIES OF MERCHANTABILITY, FITNESS FOR A PARTICULAR PURPOSE (AND THEIR EQUIVALENTS UNDER THE LAWS OF ANY JURISDICTION), OR INFRINGEMENT OF ANY PATENT, COPYRIGHT OR OTHER INTELLECTUAL PROPERTY RIGHT.

ST PRODUCTS ARE NOT DESIGNED OR AUTHORIZED FOR USE IN: (A) SAFETY CRITICAL APPLICATIONS SUCH AS LIFE SUPPORTING, ACTIVE IMPLANTED DEVICES OR SYSTEMS WITH PRODUCT FUNCTIONAL SAFETY REQUIREMENTS; (B) AERONAUTIC APPLICATIONS; (C) AUTOMOTIVE APPLICATIONS OR ENVIRONMENTS, AND/OR (D) AEROSPACE APPLICATIONS OR ENVIRONMENTS. WHERE ST PRODUCTS ARE NOT DESIGNED FOR SUCH USE, THE PURCHASER SHALL USE PRODUCTS AT PURCHASER'S SOLE RISK, EVEN IF ST HAS BEEN INFORMED IN WRITING OF SUCH USAGE, UNLESS A PRODUCT IS EXPRESSLY DESIGNATED BY ST AS BEING INTENDED FOR "AUTOMOTIVE, AUTOMOTIVE SAFETY OR MEDICAL" INDUSTRY DOMAINS ACCORDING TO ST PRODUCT DESIGN SPECIFICATIONS. PRODUCTS FORMALLY ESCC, QML OR JAN QUALIFIED ARE DEEMED SUITABLE FOR USE IN AEROSPACE BY THE CORRESPONDING GOVERNMENTAL AGENCY.

Resale of ST products with provisions different from the statements and/or technical features set forth in this document shall immediately void any warranty granted by ST for the ST product or service described herein and shall not create or extend in any manner whatsoever, any liability of ST.

ST and the ST logo are trademarks or registered trademarks of ST in various countries.

Information in this document supersedes and replaces all information previously supplied.

The ST logo is a registered trademark of STMicroelectronics. All other names are the property of their respective owners.

© 2014 STMicroelectronics - All rights reserved

STMicroelectronics group of companies

Australia - Belgium - Brazil - Canada - China - Czech Republic - Finland - France - Germany - Hong Kong - India - Israel - Italy - Japan - Malaysia - Malta - Morocco - Philippines - Singapore - Spain - Sweden - Switzerland - United Kingdom - United States of America

www.st.com

