

# L6219DS

## DUAL FULL-BRIDGE PWM MOTOR DRIVER

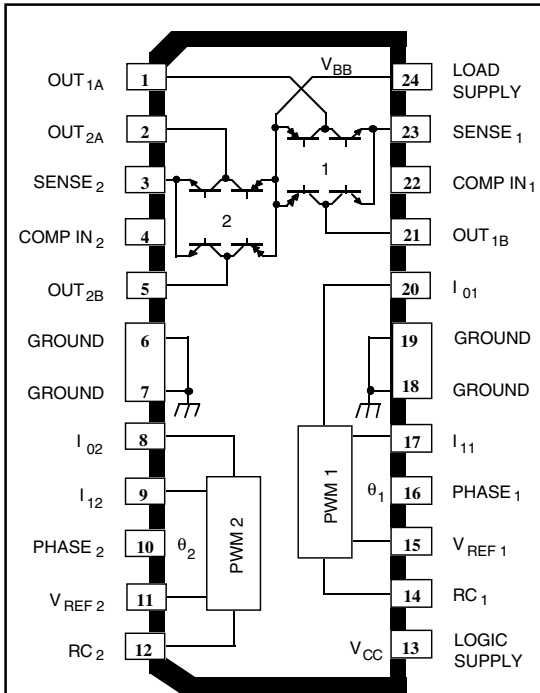

Dwg. PP-005-3

### ABSOLUTE MAXIMUM RATINGS at $T_j \leq 150^\circ\text{C}$

|  |                  |
|--|------------------|
| Motor Supply Voltage, $V_{BB}$ .....         | 45 V             |
| Output Current, $I_{OUT}$<br>(Peak) .....    | +1.0 A           |
| (Continuous) .....                           | +750 mA          |
| Logic Supply Voltage, $V_{CC}$ .....         | 7.0 V            |
| Logic Input Voltage Range,<br>$V_{IN}$ ..... | -0.3 V to +7.0 V |
| Output Emitter Voltage, $V_{SENSE}$ .....    | 1.5 V            |
| Package Power Dissipation,<br>$P_D$ .....    | See Graph        |
| Operating Temperature Range,<br>$T_A$ .....  | -20°C to +85°C   |
| Storage Temperature Range,<br>$T_S$ .....    | -55°C to +150°C  |

Output current rating may be limited by duty cycle, ambient temperature, and heat sinking. Under any set of conditions, do not exceed the specified peak current rating or a junction temperature of +150°C.

The L6219DS motor driver is designed to drive both windings of a bipolar stepper motor or bidirectionally control two dc motors. Both bridges are capable of sustaining 45 V and include internal pulse-width modulation (PWM) control of the output current to 750 mA. The outputs have been optimized for a low output saturation voltage drop (less than 1.8 V total source plus sink at 500 mA).

For PWM current control, the maximum output current is determined by the user's selection of a reference voltage and sensing resistor. Two logic-level inputs select output current limits of 0, 33, 67, or 100% of the maximum level. A PHASE input to each bridge determines load current direction.

The bridges include both ground clamp and flyback diodes for protection against inductive transients. Internally generated delays prevent cross-over currents when switching current direction. Special power-up sequencing is not required. Thermal protection circuitry disables the outputs if the chip temperature exceeds safe operating limits.

The L6219DS is supplied in a 24-lead surface-mountable SOIC. Its batwing construction provides for maximum package power dissipation in the smallest possible construction. This device is also available on special order for operation from -40°C to +85°C or to +105°C.

### FEATURES

- Interchangeable with SGS L6219DS
- 750 mA Continuous Output Current
- 45 V Output Sustaining Voltage
- Internal Clamp Diodes
- Internal PWM Current Control
- Low Output Saturation Voltage
- Internal Thermal Shutdown Circuitry
- Similar to Dual PBL3717, UC3770

Always order by complete part number, e.g., **L6219DS**.

# L6219DS

## DUAL FULL-BRIDGE

### MOTOR DRIVER

#### PWM CURRENT-CONTROL CIRCUITRY

CHANNEL 1  
TERMINAL NUMBERS  
SHOWN.

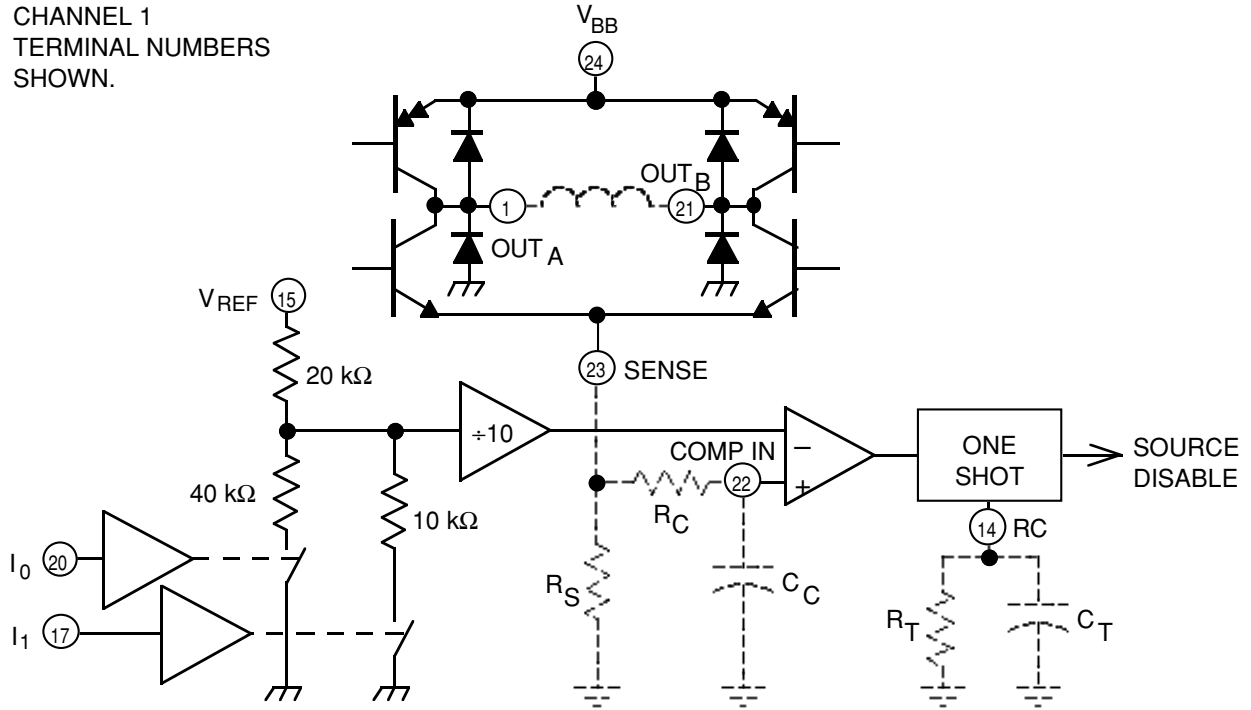

Dwg. EP-007-5

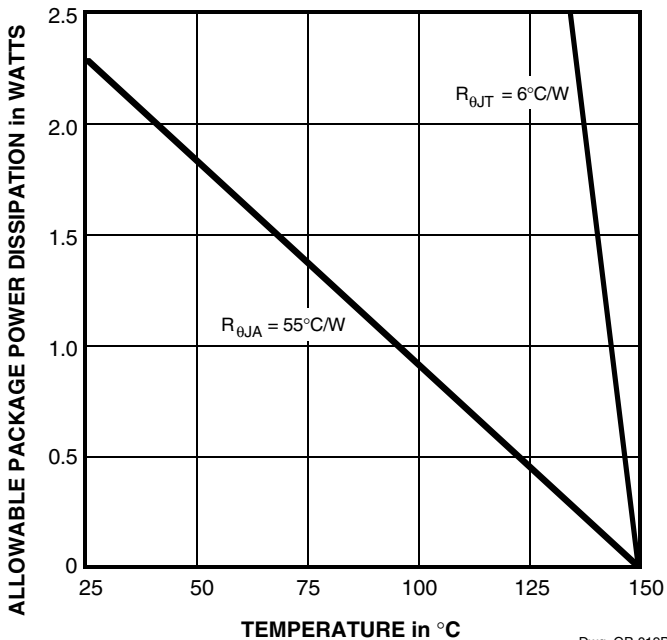

Dwg. GP-019B

#### TRUTH TABLE

| PHASE | OUT <sub>A</sub> | OUT <sub>B</sub> |
|-------|------------------|------------------|
| H     | H                | L                |
| L     | L                | H                |

# L6219DS DUAL FULL-BRIDGE MOTOR DRIVER

**ELECTRICAL CHARACTERISTICS at  $T_A = +25^\circ\text{C}$ ,  $T_J \leq 150^\circ\text{C}$ ,  $V_{BB} = 45\text{ V}$ ,  $V_{CC} = 4.75\text{ V to }5.25\text{ V}$ ,  $V_{REF} = 5.0\text{ V}$  (unless otherwise noted).**

| Characteristic   | Symbol        | Test Conditions                                     | Limits |       |      |               |
|--|---------------|---|--------|-------|------|---------------|
|  |               |   | Min.   | Typ.  | Max. | Units         |
| <b>Output Drivers (OUT<sub>A</sub> or OUT<sub>B</sub>)</b> |               |   |        |       |      |               |
| Motor Supply Range   | $V_{BB}$      |   | 10     | —     | 45   | V             |
| Output Leakage Current                                     | $I_{CEX}$     | $V_{OUT} = V_{BB}$                                  | —      | < 1.0 | 50   | $\mu\text{A}$ |
|  |               | $V_{OUT} = 0$                                       | —      | <-1.0 | -50  | $\mu\text{A}$ |
| Output Sustaining Voltage                                  | $V_{CE(sus)}$ | $I_{OUT} = \pm 750\text{ mA}$ , $L = 3.0\text{ mH}$ | 45     | —     | —    | V             |
| Output Saturation Voltage                                  | $V_{CE(SAT)}$ | Sink Driver, $I_{OUT} = +500\text{ mA}$             | —      | 0.4   | 0.6  | V             |
|  |               | Sink Driver, $I_{OUT} = +750\text{ mA}$             | —      | 1.0   | 1.2  | V             |
|  |               | Source Driver, $I_{OUT} = -500\text{ mA}$           | —      | 1.0   | 1.2  | V             |
|  |               | Source Driver, $I_{OUT} = -750\text{ mA}$           | —      | 1.3   | 1.5  | V             |
| Clamp Diode Leakage Current                                | $I_R$         | $V_R = 45\text{ V}$                                 | —      | < 1.0 | 50   | $\mu\text{A}$ |
| Clamp Diode Forward Voltage                                | $V_F$         | $I_F = 750\text{ mA}$                               | —      | 1.6   | 2.0  | V             |
| Driver Supply Current                                      | $I_{BB(ON)}$  | Both Bridges On, No Load                            | —      | 20    | 25   | mA            |
|  | $I_{BB(OFF)}$ | Both Bridges Off                                    | —      | 5.0   | 10   | mA            |

### Control Logic

|  |                      |   |      |      |      |                  |
|--|----------------------|---|------|------|------|------------------|
| Input Voltage                              | $V_{IN(1)}$          | All inputs                                  | 2.4  | —    | —    | V                |
|  | $V_{IN(0)}$          | All inputs                                  | —    | —    | 0.8  | V                |
| Input Current                              | $I_{IN(1)}$          | $V_{IN} = 2.4\text{ V}$                     | —    | <1.0 | 20   | $\mu\text{A}$    |
|  |                      | $V_{IN} = 0.8\text{ V}$                     | —    | -3.0 | -200 | $\mu\text{A}$    |
| Reference Voltage Range                    | $V_{REF}$            | Operating                                   | 1.5  | —    | 7.5  | V                |
| Current Limit Threshold<br>(at trip point) | $V_{REF}/V_{COMPIN}$ | $I_0 = I_1 = 0.8\text{ V}$                  | 9.5  | 10   | 10.5 | —                |
|  |                      | $I_0 = 2.4\text{ V}$ , $I_1 = 0.8\text{ V}$ | 13.5 | 15   | 16.5 | —                |
|  |                      | $I_0 = 0.8\text{ V}$ , $I_1 = 2.4\text{ V}$ | 25.5 | 30   | 34.5 | —                |
| Thermal Shutdown Temperature               | $T_J$                |   | —    | 170  | —    | $^\circ\text{C}$ |
| Total Logic Supply Current                 | $I_{CC(ON)}$         | $I_0 = I_1 = 0.8\text{ V}$ , No Load        | —    | 40   | 50   | mA               |
|  | $I_{CC(OFF)}$        | $I_0 = I_1 = 2.4\text{ V}$ , No Load        | —    | 10   | 12   | mA               |

# L6219DS

## DUAL FULL-BRIDGE

### MOTOR DRIVER

## APPLICATIONS INFORMATION

### PWM CURRENT CONTROL

The L6219DS dual bridge is designed to drive both windings of a bipolar stepper motor. Output current is sensed and controlled independently in each bridge by an external sense resistor ( $R_S$ ), internal comparator, and monostable multivibrator.

When the bridge is turned on, current increases in the motor winding and it is sensed by the external sense resistor until the sense voltage ( $V_{COMPIN}$ ) reaches the level set at the comparator's input:

$$I_{TRIP} = V_{REF} / 10 R_S$$

The comparator then triggers the monostable which turns off the source driver of the bridge. The actual load current peak will be slightly higher than the trip point (especially for low-inductance loads) because of the internal logic and switching delays. This delay ( $t_d$ ) is typically 2  $\mu$ s. After turn-off, the motor current decays, circulating through the ground-clamp diode and sink transistor. The source driver's off time (and therefore the magnitude of the current decrease) is determined by the monostable's external RC timing components, where  $t_{off} = R_T C_T$ , within the range of 20 k $\Omega$  to 100 k $\Omega$  and 100 pF to 1000 pF.

When the source driver is re-enabled, the winding current (the sense voltage) is again allowed to rise to the comparator's threshold. This cycle repeats itself, maintaining the average motor winding current at the desired level.

Loads with high distributed capacitances may result in high turn-on current peaks. This peak (appearing across  $R_S$ ) will attempt to trip the comparator, resulting in erroneous current control or high-frequency oscillations. An external  $R_C C_C$  time delay should be used to further delay the action of the comparator. Depending on load type, many applications will not require these external components (SENSE connected to COMP IN).

### PWM OUTPUT CURRENT WAVE FORM

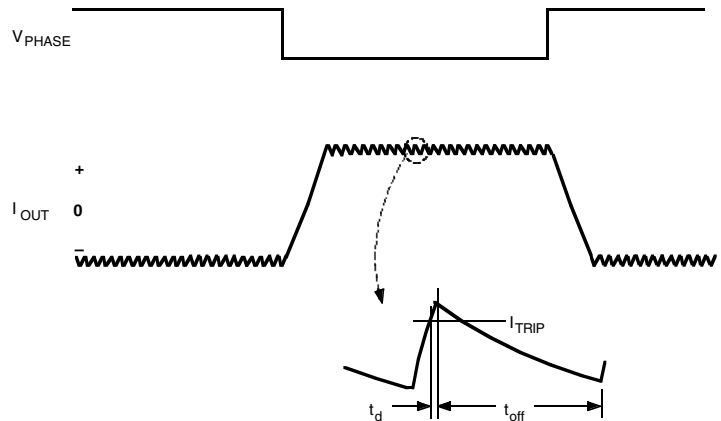

Dwg. WM-003-1A

### LOAD CURRENT PATHS

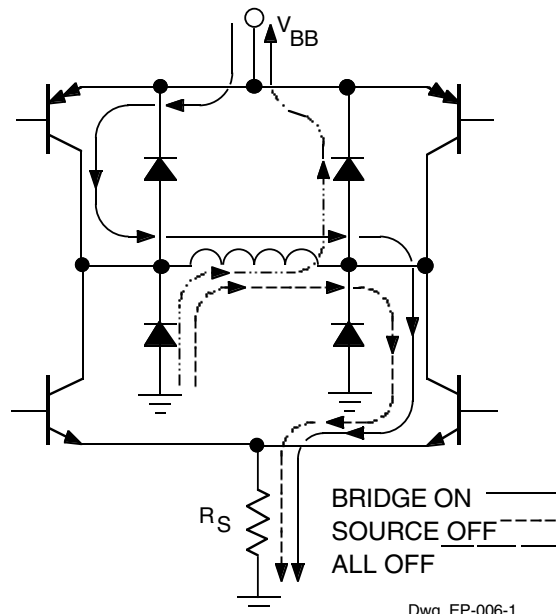

Dwg. EP-006-1

# L6219DS

## DUAL FULL-BRIDGE

### MOTOR DRIVER

#### LOGIC CONTROL OF OUTPUT CURRENT

Two logic level inputs ( $I_0$  and  $I_1$ ) allow digital selection of the motor winding current at 100%, 67%, 33%, or 0% of the maximum level per the table. The 0% output current condition turns off all drivers in the bridge and can be used as an OUTPUT ENABLE function.

#### CURRENT-CONTROL TRUTH TABLE

| $I_0$ | $I_1$ | Output Current                  |
|-------|-------|---------------------------------|
| L     | L     | $V_{REF}/10 R_S = I_{TRIP}$     |
| H     | L     | $V_{REF}/15 R_S = 2/3 I_{TRIP}$ |
| L     | H     | $V_{REF}/30 R_S = 1/3 I_{TRIP}$ |
| H     | H     | 0                               |

These logic level inputs greatly enhance the implementation of  $\mu$ P-controlled drive formats.

During half-step operations, the  $I_0$  and  $I_1$  allow the  $\mu$ P to control the motor at a constant torque between all positions in an eight-step

sequence. This is accomplished by digitally selecting 100% drive current when only one phase is on and 67% drive current when two phases are on. Logic highs on both  $I_0$  and  $I_1$  turn off all drivers to allow rapid current decay when switching phases. This helps to ensure proper motor operation at high step rates.

The logic control inputs can also be used to select a reduced current level (and reduced power dissipation) for 'hold' conditions and/or increased current (and available torque) for start-up conditions.

#### GENERAL

The PHASE input to each bridge determines the direction motor winding current flows. An internally generated deadtime (approximately 2  $\mu$ s) prevents crossover currents that can occur when switching the PHASE input.

All four drivers in the bridge output can be turned off between steps ( $I_0 = I_1 \geq 2.4$  V) resulting in a fast current decay through the internal output clamp and flyback diodes. The fast current decay is desirable in half-step and high-speed applications. The PHASE,  $I_0$ , and  $I_1$  inputs float high.

Varying the reference voltage ( $V_{REF}$ ) provides continuous control of the peak load current for microstepping applications.

Thermal protection circuitry turns off all drivers when the junction temperature reaches +170°C. It is only intended to protect the device from failures due to excessive junction temperature and should not imply that output short circuits are permitted. The output drivers are re-enabled when the junction temperature cools to +145°C.

The L6219DS output drivers are optimized for low output saturation voltages—less than 1.8 V total (source plus sink) at 500 mA. Under normal operating conditions, when combined with the excellent thermal properties of the batwing package design, this allows continuous operation of both bridges simultaneously at 500 mA.

#### TYPICAL APPLICATION

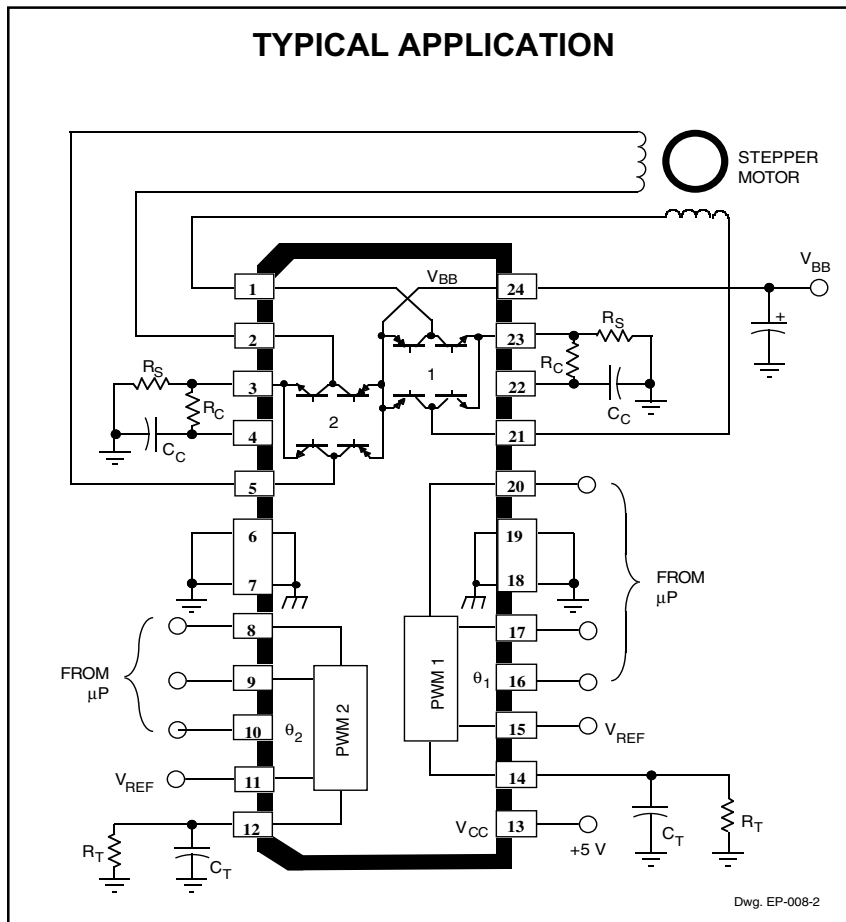

# L6219DS

## DUAL FULL-BRIDGE

### MOTOR DRIVER

#### Dimensions in Inches

(for reference only)

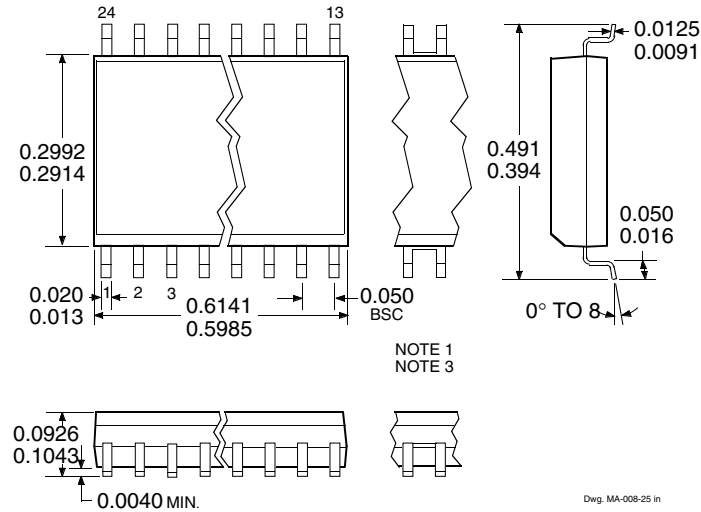

#### Dimensions in Millimeters

(controlling dimensions)

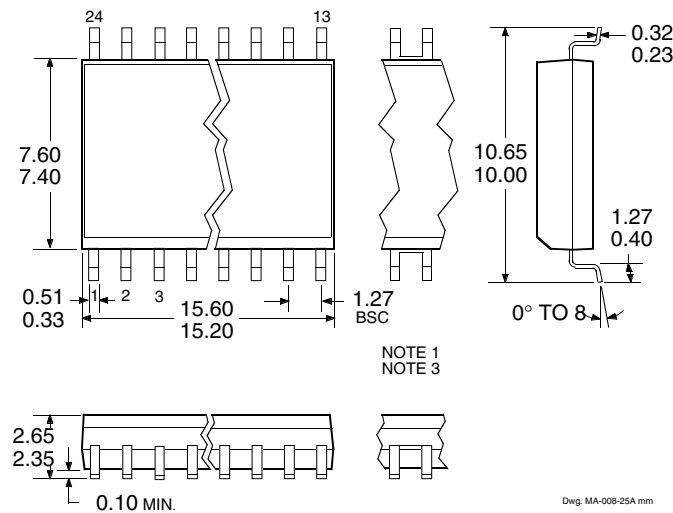

- NOTES: 1. Webbed lead frame. Leads indicated are internally one piece.  
 2. Lead spacing tolerance is non-cumulative.  
 3. Exact body and lead configuration at vendor's option within limits shown.

**L6219DS**  
**DUAL FULL-BRIDGE**  
**MOTOR DRIVER**

## **BRIDGE & HALF-BRIDGE DRIVERS**

IN ORDER OF 1) OUTPUT CURRENT AND 2) OUTPUT VOLTAGE

| Output Ratings * |    | Description                     | Features        |                        |                     | Part Number † |
|------------------|----|---------------------------------|-----------------|------------------------|---------------------|---------------|
| mA               | V  |                                 | Internal Diodes | Outputs                | Internal Protection |               |
| ±650             | 30 | dual PWM full bridge            | X               | bipolar                | X                   | 3966          |
|                  | 30 | dual PWM full bridge            | X               | bipolar                | X                   | 3968          |
| ±750             | 45 | dual PWM full bridge            | X               | bipolar                | X                   | 2916          |
|                  | 45 | dual PWM full bridge            | X               | bipolar                | X                   | 2919          |
|                  | 45 | dual PWM full bridge            | X               | bipolar                | X                   | 6219          |
| ±800             | 33 | dual PWM full bridge            | X               | bipolar                | X                   | 3964          |
| ±900             | 14 | 3-Ø back-EMF controller/driver  | X               | DMOS                   | X                   | 8902-A        |
| ±1300            | 50 | PWM full bridge                 | X               | bipolar                | X                   | 3953          |
| ±1500            | 45 | dual PWM full bridge            | X               | bipolar                | X                   | 2917          |
|                  | 45 | dual PWM full bridge            | X               | bipolar                | X                   | 2918          |
|                  | 50 | PWM microstepping full bridge   | X               | Darlington/Satlington™ | X                   | 3955          |
|                  | 50 | PWM microstepping full bridge   | X               | Darlington/Satlington™ | X                   | 3957          |
| ±2000            | 45 | 3-Ø brushless controller/driver | X               | Darlington             | X                   | 2936          |
|                  | 50 | dual full bridge                | X               | Darlington             | X                   | 2998          |
|                  | 50 | PWM full-bridge                 | X               | Darlington             | X                   | 3951          |
|                  | 50 | PWM full-bridge                 | X               | Darlington             | X                   | 3952          |
|                  | 50 | PWM full-bridge                 | X               | DMOS                   | X                   | 3958          |
| ±3000            | 45 | PWM control                     | X               | Darlington             | –                   | 2962          |
| ±3400            | 45 | PWM control                     | X               | bipolar                | X                   | 2961          |
| —                | 28 | 3-Ø MOSFET controller           | –               | DMOS                   | X                   | 3933          |

\* Current is maximum specified test condition, voltage is maximum rating. See specification for sustaining voltage limits or over-current protection voltage limits.

† Complete part number includes additional characters to indicate operating temperature range and package style.

# **L6219DS**

## ***DUAL FULL-BRIDGE***

### ***MOTOR DRIVER***

*The products described here are manufactured under one or more U.S. patents or U.S. patents pending.*

*Allegro MicroSystems, Inc. reserves the right to make, from time to time, such departures from the detail specifications as may be required to permit improvements in the performance, reliability, or manufacturability of its products. Before placing an order, the user is cautioned to verify that the information being relied upon is current.*

*Allegro products are not authorized for use as critical components in life-support devices or systems without express written approval.*

*The information included herein is believed to be accurate and reliable. However, Allegro MicroSystems, Inc. assumes no responsibility for its use; nor for any infringement of patents or other rights of third parties which may result from its use.*



115 Northeast Cutoff, Box 15036  
Worcester, Massachusetts 01615-0036 (508) 853-5000