

1A step-down switching regulator

Features

- 1A DC output current
- 2.9V to 18V input voltage
- Output voltage adjustable from 0.6V
- 250kHz switching frequency, programmable up to 1MHz
- Internal soft-start and inhibit
- Low dropout operation: 100% duty cycle
- Voltage feed-forward
- Zero load current operation
- Over current and thermal protection
- VQFN3x3-8L package

Applications

- Consumer: STB, DVD, DVD recorder, car audio, LCD TV and monitors
- Industrial: Chargers, car battery, PLD, PLA, FPGA
- Networking: XDSL, modems, DC-DC modules
- Computer: Optical storage, hard disk drive, printers, audio/graphic cards

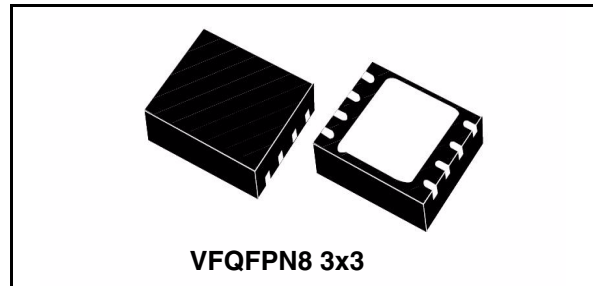

Description

The L5981 is step down switching regulator with 1.5A current limited embedded power MOSFET, so it is able to deliver in excess of 1A DC current to the load depending on the application condition.

The input voltage can range from 2.9V to 18V, while the output voltage can be set starting from 0.6V to V_{IN} . Having a minimum input voltage of 2.9V, the device is suitable also for 3.3V bus.

Requiring a minimum set of external components, the device includes an internal 250kHz switching frequency oscillator that can be externally adjusted up to 1MHz.

The QFN package with exposed pad allows reducing the R_{thJA} down to approximately 60°C/W.

Figure 1. Application circuit

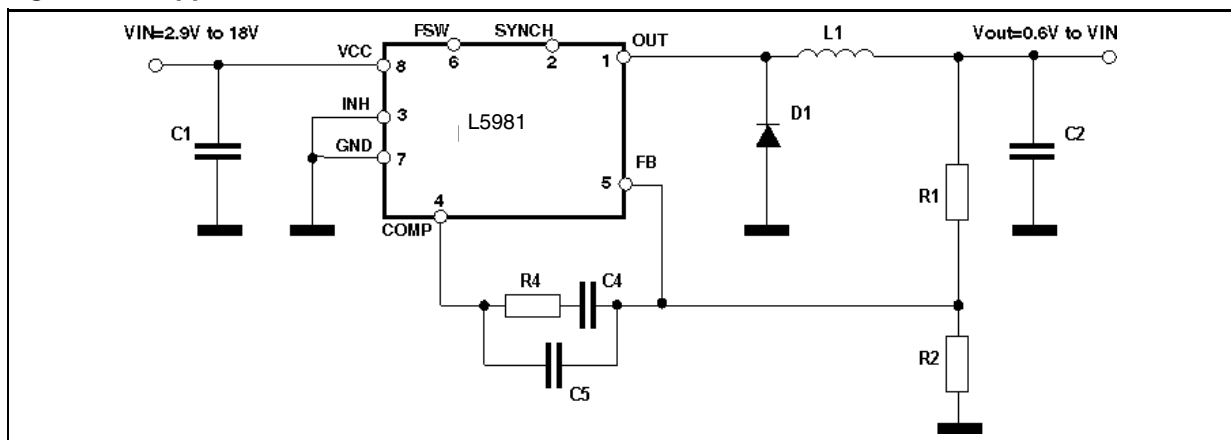

Contents

- 1 Pin settings 3**
 - 1.1 Pin connection 3
 - 1.2 Pin description 3
- 2 Maximum ratings 4**
- 3 Electrical characteristics 5**
- 4 Functional description 7**
 - 4.1 Oscillator and synchronization 8
 - 4.2 Soft-start 10
 - 4.3 Error amplifier and compensation 11
 - 4.4 Over-current protection 12
 - 4.5 Inhibit function 13
 - 4.6 Hysteretic thermal shutdown 13
- 5 Application informations 14**
 - 5.1 Input capacitor selection 14
 - 5.2 Inductor selection 15
 - 5.3 Output capacitor selection 16
 - 5.4 Compensation network 17
 - 5.4.1 Type III compensation network 18
 - 5.4.2 Type II compensation network 23
 - 5.5 Thermal considerations 26
 - 5.6 Layout considerations 27
 - 5.7 Application circuit 29
- 6 Package mechanical data 33**
- 7 Order codes 35**
- 8 Revision history 36**

1 Pin settings

1.1 Pin connection

Figure 2. Pin connection (top view)

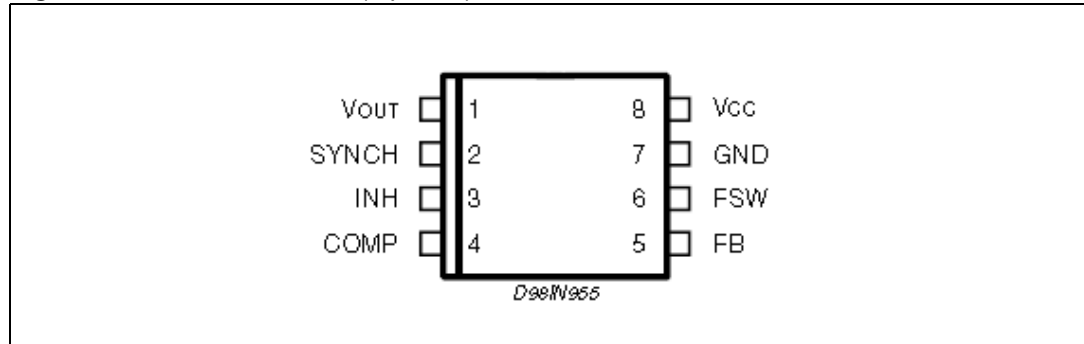

1.2 Pin description

Table 1. Pin description

N.	Type	Description
1	OUT	Regulator output
2	SYNCH	Master/Slave Synchronization. When it is left floating, a signal with a phase shift of half a period respect to the power turn on is present at the pin. When connected to an external signal at a frequency higher than the internal one, then the device is synchronized by the external signal, with zero phase shift. Connecting together the SYNC pin of two devices, the one with higher frequency works as master and the other one as slave; so the two powers turn on have a phase shift of half a period.
3	INH	A logical signal (active high) disable the device. With INH higher than 1.9V the device is OFF and with INH lower than 0.6V the device is ON.
4	COMP	Error Amplifier output to be used for loop frequency compensation
5	FB	Feedback input. Connecting the output voltage directly to this pin the output voltage is regulated at 0.6V. To have higher regulated voltages an external resistor divider is required from Vout to FB pin.
6	F _{SW}	The switching frequency can be increased connecting an external resistor from FSW pin and ground. If this pin is left floating the device works at its free-running frequency of 250kHz.
7	GND	Ground
8	V _{CC}	Unregulated DC input voltage

2 Maximum ratings

Table 2. Absolute maximum ratings

Symbol	Parameter	Value	Unit
V _{CC}	Input voltage	20	V
OUT	Output DC voltage	-0.3 to V _{CC}	
F _{SW} , COMP, SYNCH	Analog pin	-0.3 to 4	
INH	Inhibit pin	-0.3 to V _{CC}	
FB	Feedback voltage	-0.3 to 1.5	
P _{TOT}	Power dissipation at T _A < 60°C	1.5.	W
T _J	Junction temperature range	-40 to 150	°C
T _{stg}	Storage temperature range	-55 to 150	°C

3 Electrical characteristics

T_J=25°C, V_{CC}=12V, unless otherwise specified.

Table 3. Electrical characteristics

Symbol	Parameter	Test condition	Values			Unit
			Min	Typ	Max	
V _{CC}	Operating input voltage range	(1)	2.9		18	V
V _{CCON}	Turn on V _{CC} threshold	(1)			2.9	
V _{CCOFF}	Turn off V _{CC} threshold	(1)	2.4			
R _{DSON}	MOSFET on resistance		x	150	x	mΩ
		(1)		150	300	
I _{LIM}	Maximum limiting current		1.5	1.8	2.1	A
Oscillator						
F _{SW}	Switching frequency		225	250	275	kHz
		(1)	x	250	x	
V _{FSW}	FSW pin voltage			1.262		V
D	Duty Cycle		0		100	%
F _{ADJ}	Adjustable switching frequency	R _{FSW} =33kΩ		1000		kHz
Dynamic characteristics						
V _{FB}	Feedback voltage	2.9V<V _{CC} <18V	0.593	0.6	0.607	V
DC characteristics						
I _Q	Quiescent current	Duty Cycle=0, V _{FB} =0.8V			2.4	mA
I _{QST-BY}	Total stand-by quiescent current			20	30	μA
Inhibit						
	INH threshold voltage	Device ON level			0.6	V
		Device OFF level	1.9			
	INH current	INH=0		7.5	10	μA
Soft start						
T _{SS}	Soft start duration	F _{SW} =Floating	7.4	8.2	9.1	ms
		F _{SW} =1MHz, R _{FSW} =33kΩ		2		

Table 3. Electrical characteristics

Symbol	Parameter	Test condition	Values			Unit
			Min	Typ	Max	
Error amplifier						
V _{CH}	High level output voltage	V _{FB} <0.6V	3			V
V _{CL}	Low level output voltage	V _{FB} >0.6V			0.1	
I _{FB}	Bias source current	V _{FB} =0V to 0.8V		1		μA
I _{O SOURCE}	Source COMP pin	V _{FB} =0.5V, V _{COMP} =1V		17		mA
I _{O SINK}	Sink COMP pin	V _{FB} =0.7V, V _{COMP} =1V		25		mA
G _V	Open loop voltage gain	⁽²⁾		100		dB
Synchronization function						
	High input voltage		2		3.3	V
	Low input voltage				1	
	Slave sink current	V _{SYNCH} =2.9V		0.7	0.9	mA
	Master output amplitude	I _{SOURCE} =200μA		3.0		V
	Output pulse width	SYNCH floating		110		ns
	Input pulse width		70			
Protection						
I _{FBDISC}	FB disconnection source current			1		μA
T _{SHDN}	Thermal shutdown			150		°C
	Hystereris			30		

1. Specification referred to T_J from -40 to +125°C. Specification in the -40 to +125°C temperature range are assured by design, characterization and statistical correlation.

2. Guaranteed by design.

4 Functional description

The L5981 is based on a “voltage mode”, constant frequency control. The output voltage V_{OUT} is sensed by the feedback pin (FB) compared to an internal reference (0.6V) providing an error signal that, compared to a fixed frequency sawtooth, controls the on and off time of the power switch.

The main internal blocks are shown in the block diagram in *Figure 3*. They are:

- A fully integrated oscillator that provides sawtooth to modulate the duty cycle and the synchronization signal. Its switching frequency can be adjusted by an external resistor. The voltage and frequency feed forward are implemented.
- The soft start circuitry to limit inrush current during the start up phase.
- The voltage mode Error Amplifier
- The Pulse Width Modulator and the relative logic circuitry necessary to drive the internal power switch.
- The High-side driver for embedded p-channel power MOSFET switch.
- The peak current limit sensing block, to handle over load and short circuit conditions.
- A voltage regulator and internal reference. It supplies internal circuitry and provides a fixed internal reference.
- A voltage monitor circuitry (UVLO) that checks the input and internal voltages.
- A thermal shutdown block, to prevent thermal run away.

Figure 3. Block diagram

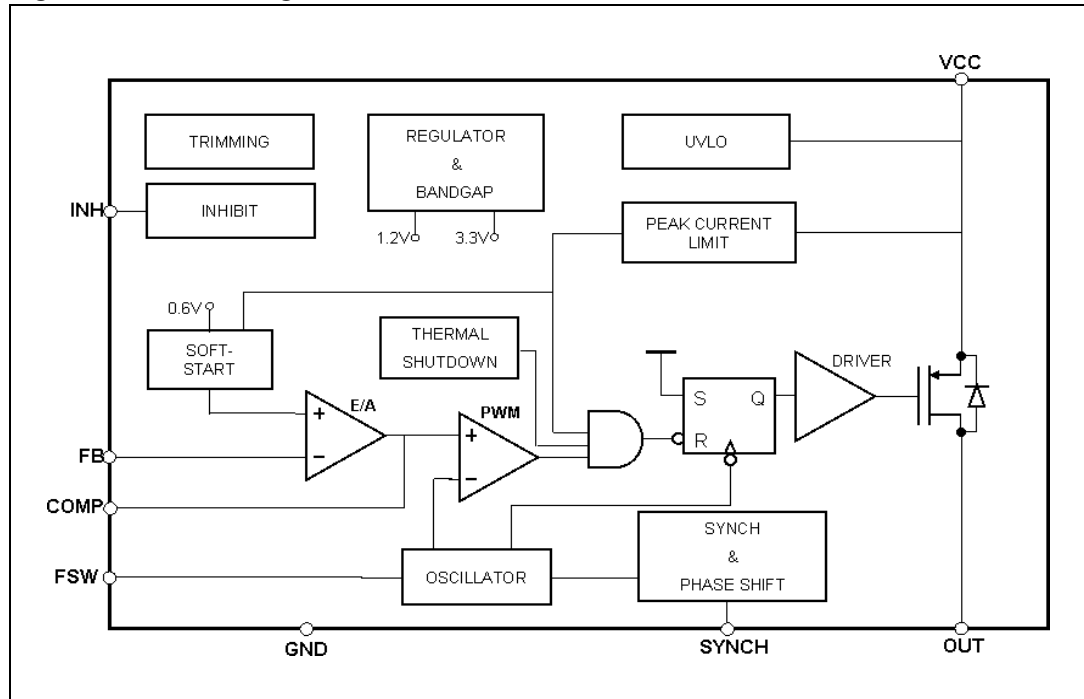

4.1 Oscillator and synchronization

Figure 4 shows the block diagram of the oscillator circuit. The internal oscillator provides a constant frequency clock. Its frequency depends on the resistor externally connect to FSW pin. In case the FSW pin is left floating the frequency is 250KHz; it can be increased as shown in Figure 6 by external resistor connected to ground.

To improve the line transient performance and to keep the PWM gain constant versus the input voltage, the voltage feed forward is implemented by changing the slope of the sawtooth according to the input voltage change (see Figure 5.a).

The slope of the sawtooth also changes if the oscillator frequency is increased by the external resistor. In this way a frequency feed forward is implemented (Figure 5.b) in order to keep the PWM gain constant versus the switching frequency (see Section 5.4 for PWM gain expression).

On the SYNCH pin the synchronization signal is generated. This signal has a phase shift of 180° with respect to the clock. This delay is useful when two devices are synchronized connecting the SYNCH pin together. When SYNCH pins are connected, the device with higher oscillator frequency works as Master, so the Slave device switches at the frequency of the Master but with a delay of half a period. This minimizes the RMS current flowing through the input capacitor [see L5988D Data sheet].

Figure 4. Oscillator circuit block diagram

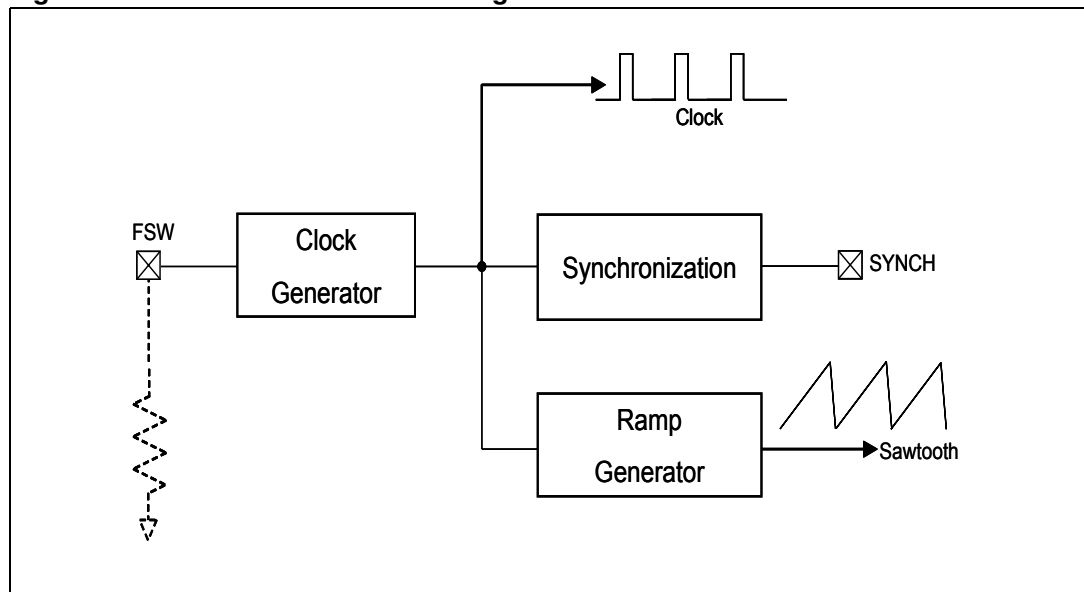

The device can be synchronized to work at higher frequency feeding an external clock signal. The synchronization changes the sawtooth amplitude, changing the PWM gain (Figure 5.c). This changing has to be taken into account when the loop stability is studied. To minimize the change of the PWM gain, the free running frequency should be set (with a resistor on FSW pin) only slightly lower than the external clock frequency. This pre-adjusting of the frequency will change the sawtooth slope in order to get negligible the truncation of sawtooth, due to the external synchronization.

Figure 5. Sawtooth: voltage and frequency feed forward; external synchronization.

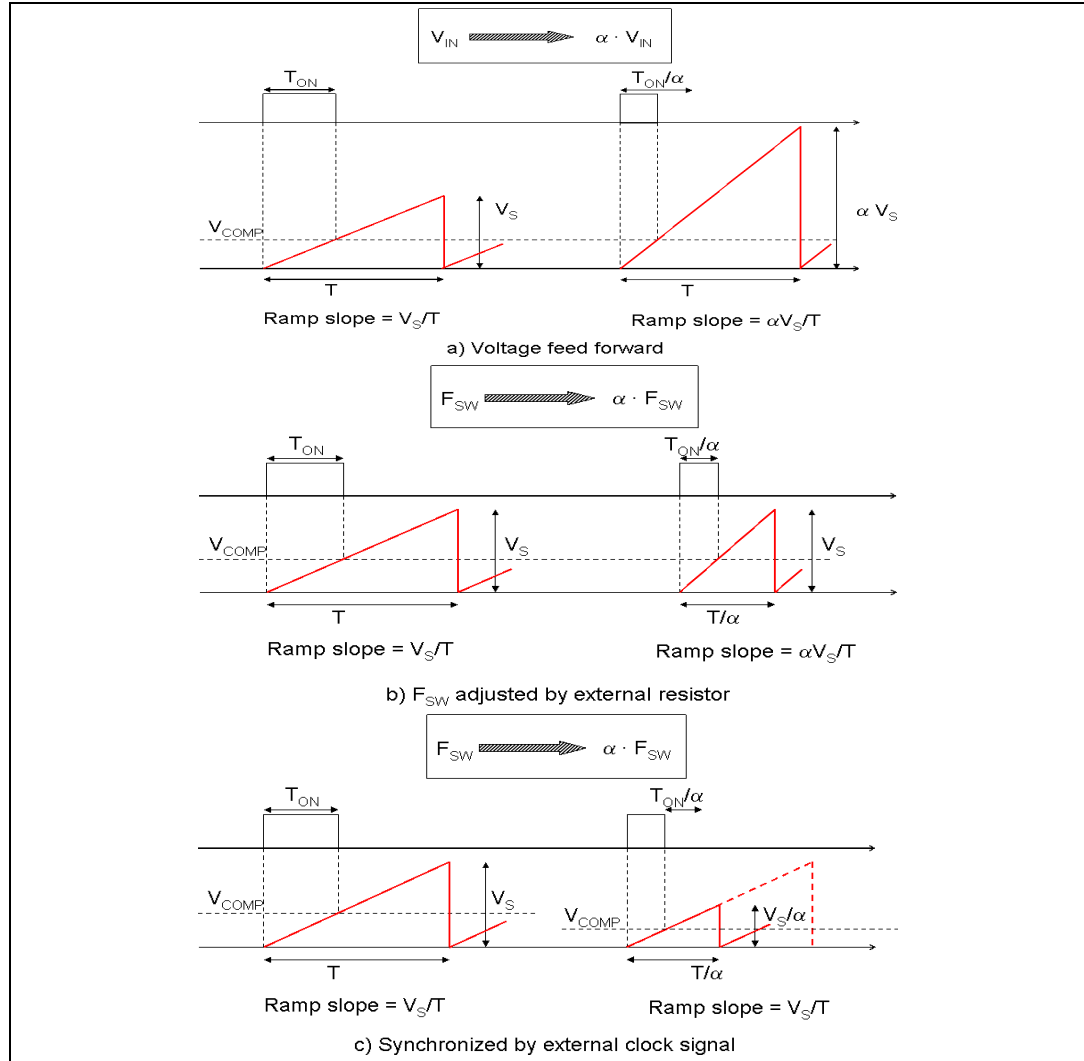
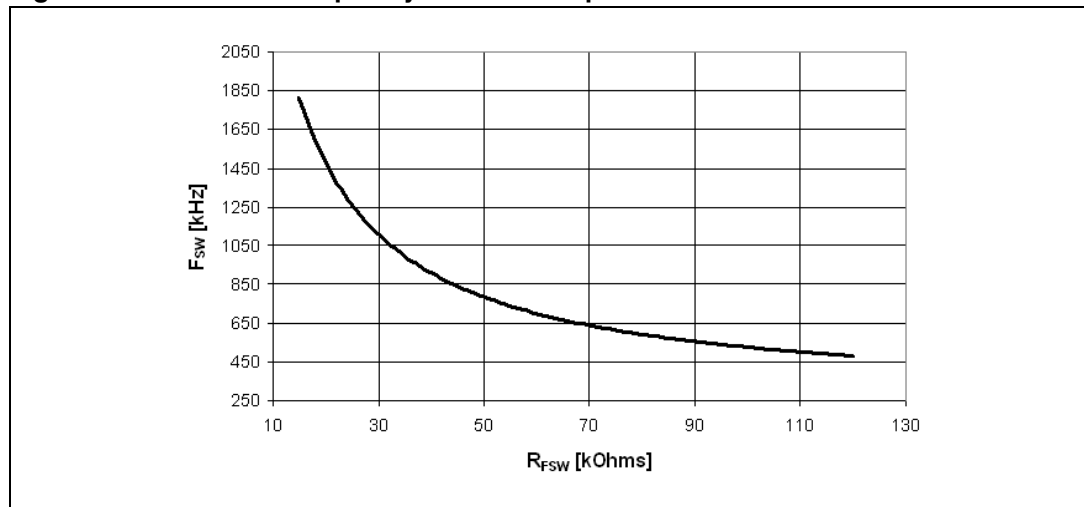

Figure 6. Oscillator frequency versus FSW pin resistor



4.2 Soft-start

The soft-start is essential to assure correct and safe start up of the step-down converter. It avoids inrush current surge and makes the output voltage increases monothonically.

The soft -start is performed by a staircase ramp on the non-inverting input (V_{REF}) of the Error Amplifier. So the output voltage slew rate is:

Equation 1

$$SR_{OUT} = SR_{VREF} \cdot \left(1 + \frac{R1}{R2}\right)$$

where SR_{VREF} is the slew rate of the non-inverting input and R1, R2 is the resistor divider to regulate the output voltage (see [Figure 7](#)). The soft-start stair case consists of 64 steps of 9.5mV each one, from 0V to 0.6V. The time base of one step is of 32 clock cycles. So the soft start time and then the output voltage slew rate depend on the switching frequency.

Figure 7. Soft start scheme.

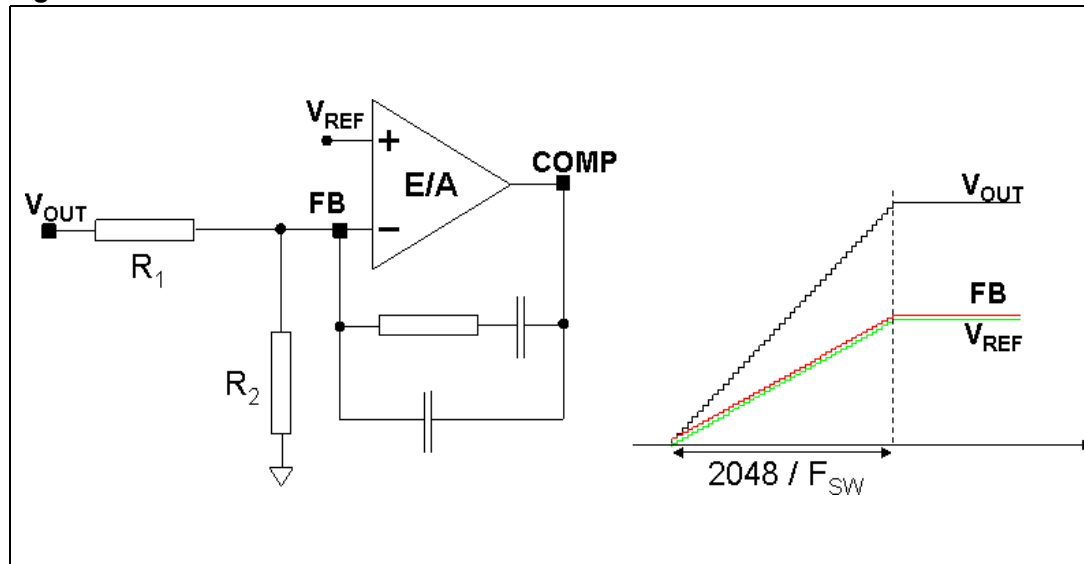

Soft start time results:

Equation 2

$$SS_{TIME} = \frac{32 \cdot 64}{F_{SW}}$$

For example with a switching frequency of 250kHz the SS_{TIME} is 8ms.

4.3 Error amplifier and compensation

The Error Amplifier (E/A) provides the error signal to be compared with the sawtooth to perform the Pulse Width Modulation. Its non-inverting input is internally connected to a 0.6V voltage reference, while its inverting input (FB) and output (COMP) are externally available for feedback and frequency compensation. In this device the Error amplifier is a Voltage Mode Operational Amplifier so with high DC gain and low output impedance.

The uncompensated Error Amplifier characteristics are the following:

Table 4. Uncompensated error amplifier characteristics

Low frequency Gain	100dB
GBWP	4.5MHz
Slew Rate	7V/ μ s
Output voltage swing	0 to 3.3V
Maximum source/sink current	25mA/40mA

In continuous conduction mode (CCM), the transfer function of the power section has two poles due to the LC filter and one zero due to the ESR of the output capacitor. Different kinds of compensation networks can be used depending on the ESR value of the output capacitor. In case the zero introduced by the output capacitor helps to compensate the double pole of the LC filter a type II compensation network can be used. Otherwise, a type III compensation network has to be used (see [Chapter 5.4](#) for details about the compensation network selection).

Anyway the methodology to compensate the loop is to introduce zeros to obtain a safe phase margin.

4.4 Over-current protection

The L5981 implements the over current protection sensing current flowing through the power MOSFET. Due to the noise created by the switching activity of the power MOSFET, the current sensing is disabled during the initial phase of the conduction time. This avoids an erroneous detection of a fault condition. This interval is generally known as “masking time” or “blanking time”. The masking time is about 200ns.

When the over current is detected, two different behaviors are possible depending on the operation condition.

1. **Output voltage in regulation.** When the over current is sensed, the power MOSFET is switched off and the internal reference (V_{REF}), that biases the non-inverting input of the error amplifier, is set to zero and kept in this condition for a soft start time (T_{SS} , 2048 clock cycles). After this time, a new soft start phase takes place and the internal reference begins ramping (see [Figure 8.a](#)).
2. **Soft start phase.** If the over current limit is reached the power MOSFET is turned off implementing the pulse by pulse over current protection. During the soft start phase, under over current condition, the device can skip pulses in order to keep the output current constant and equal to the current limit. If at the end of the "masking time" the current is higher than the over current threshold, the power MOSFET is turned off and it will skip one pulse. If, at the next switching on at the end of the "masking time" the current is still higher than the threshold, the device will skip two pulses. This mechanism is repeated and the device can skip up to seven pulses. While, if at the end of the "masking time" the current is lower than the over current threshold, the number of skipped cycles is decreased of one unit. At the end of soft start phase the output voltage is in regulation and if the over current persists the behavior explained above take place. (see [Figure 8.b](#))

So the over current protection can be summarized as an “hiccup” intervention when the output is in regulation and a constant current during the soft start phase. If the output is shorted to ground when the output voltage is on regulation, the over current is triggered and the device starts cycling with a period of 2048 clock cycles between “hiccup” (power MOSFET off and no current to the load) and “constant current” with very short on-time and with reduced switching frequency (up to one eighth of normal switching frequency). See [Figure 32](#) for short circuit behavior.

Figure 8. Over current protection strategy

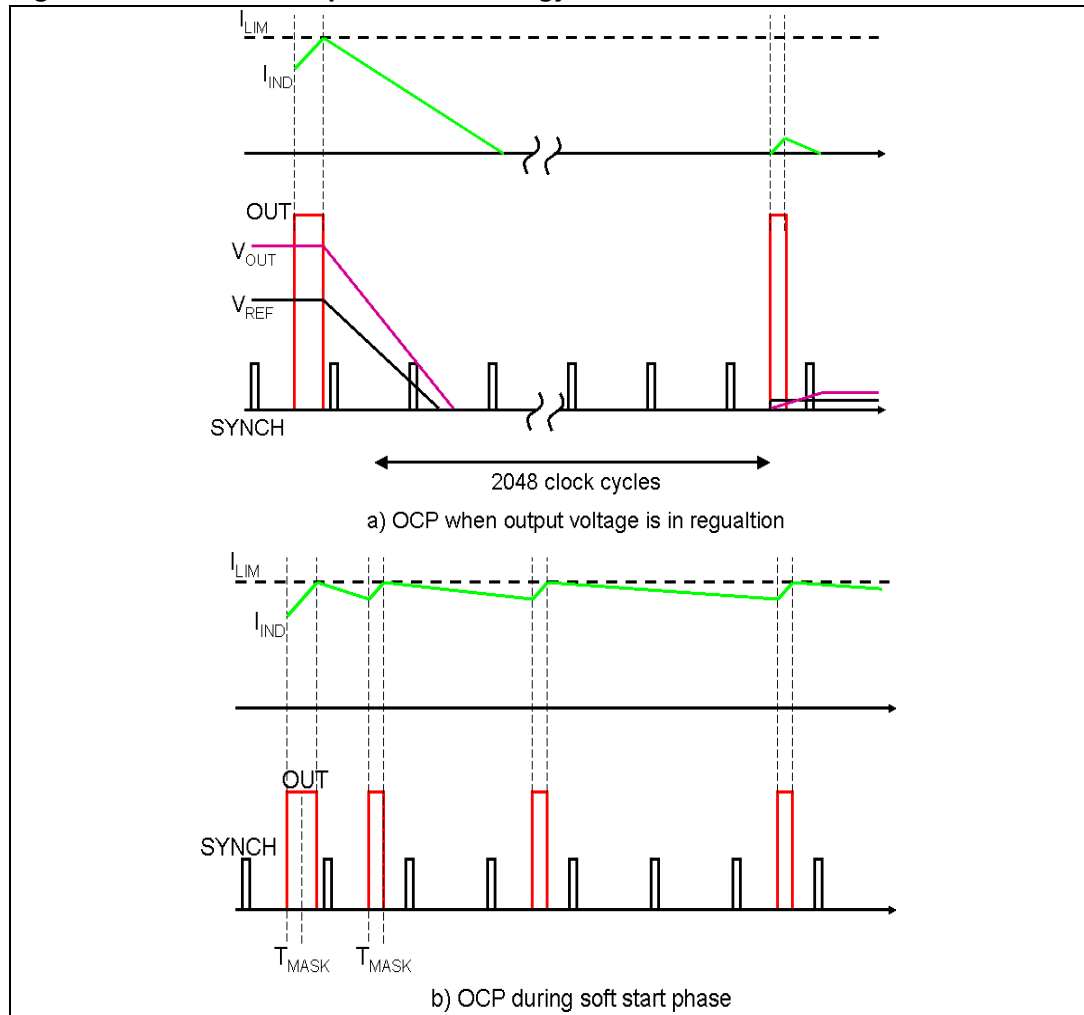

4.5 Inhibit function

The inhibit feature allows to put in stand-by mode the device. With INH pin higher than 1.9V the device is disabled and the power consumption is reduced to less than 30uA. With INH pin lower than 0.6V, the device is enabled. If the INH pin is left floating, an internal pull up ensures that the voltage at the pin reaches the inhibit threshold and the device is disabled. The pin is also VCC compatible.

4.6 Hysteretic thermal shutdown

The thermal shutdown block generates a signal that turns off the power stage if the junction temperature goes above 150°C. Once the junction temperature goes back to about 130°C, the device restarts in normal operation. The sensing element is very close to the PDMOS area, so ensuring an accurate and fast temperature detection.

5 Application informations

5.1 Input capacitor selection

The capacitor connected to the input has to be capable to support the maximum input operating voltage and the maximum RMS input current required by the device. The input capacitor is subject to a pulsed current, the RMS value of which is dissipated over its ESR, affecting the overall system efficiency.

So the input capacitor must have a RMS current rating higher than the maximum RMS input current and an ESR value compliant with the expected efficiency.

The maximum RMS input current flowing through the capacitor can be calculated as:

Equation 3

$$I_{RMS} = I_O \cdot \sqrt{D - \frac{2 \cdot D^2}{\eta} + \frac{D^2}{\eta}}$$

Where I_O is the maximum DC output current, D is the duty cycle, η is the efficiency. This function has a maximum at $D=0.5$ and, considering $\eta=1$, it is equal to $I_O/2$.

In a specific application the range of possible duty cycles has to be considered in order to find out the maximum RMS input current. The maximum and minimum duty cycles can be calculated as:

Equation 4

$$D_{MAX} = \frac{V_{OUT} + V_F}{V_{INMIN} - V_{SW}}$$

and

Equation 5

$$D_{MIN} = \frac{V_{OUT} + V_F}{V_{INMAX} - V_{SW}}$$

Where V_F is the forward voltage on the freewheeling diode and V_{SW} is voltage drop across the internal PDMOS. In [Table 5](#), some Multi Layer Ceramic capacitors suitable for this device are reported

Table 5. Input MLCC capacitors

Manufacture	Series	Cap value (μ F)	Rated Voltage (V)
MURATA	GRM31	10	25
	GRM55	10	25
TDK	C3225	10	25

5.2 Inductor selection

The inductance value fixes the current ripple flowing through the output capacitor. So the minimum inductance value in order to have the expected current ripple has to be selected. The rule to fix the current ripple value is to have a ripple at 20%-40% of the output current. The inductance value can be calculated by the following equation:

Equation 6

$$\Delta I_L = \frac{V_{IN} - V_{OUT}}{L} \cdot T_{ON} = \frac{V_{OUT}}{L} \cdot T_{OFF}$$

Where T_{ON} and T_{OFF} are the on and off time of the internal power switch. The maximum current ripple, at fixed V_{out} , is obtained at maximum T_{OFF} that is at minimum duty cycle (see previous section to calculate minimum duty). So fixing $\Delta I_L=20\%$ to 40% of the maximum output current, the minimum inductance value can be calculated:

Equation 7

$$L_{MIN} = \frac{V_{OUT} + V_F}{\Delta I_{MAX}} \cdot \frac{1 - D_{MIN}}{F_{SW}}$$

where F_{SW} is the switching frequency, $1/(T_{ON} + T_{OFF})$.

For example for $V_{OUT}=3.3V$, $V_{IN}=12V$, $I_O=1A$ and $F_{SW}=250kHz$ the minimum inductance value to have $\Delta I_L=30\%$ of I_O is about $31\mu H$.

The peak current through the inductor is given by:

Equation 8

$$I_{L,PK} = I_O + \frac{\Delta I_L}{2}$$

So if the inductor value decreases, the peak current (that has to be lower than the current limit of the device) increases. The higher is the inductor value, the higher is the average output current that can be delivered, without reaching the current limit.

In the table below some inductor part numbers are listed.

Table 6. Inductors

Manufacturer	Series	Inductor Value (μH)	Saturation Current (A)
Würth	TPC XLH	22 to 47	1.85 to 2.3
	PD M	10 to 18	1.7 to 2.2
Coilcraft	MSS1038	22 to 47	1.9 to 2.9
	LPS6235	10 to 18	1.8 to 2.4

Table 6. Inductors

Manufacturer	Series	Inductor Value (μH)	Saturation Current (A)
Coiltronics	DRQ73	10 to 22	1.67 to 2.47
	LD2	27 to 47	1.64 to 2.1
SUMIDA	CDR6D28MN	10 to 22	1.65 to 2.5
	CDRH105RNP	27 to 56	1.9 to 2.7

5.3 Output capacitor selection

The current in the capacitor has a triangular waveform which generates a voltage ripple across it. This ripple is due to the capacitive component and the resistive component (ESR). So the output capacitor has to be selected in order to have a voltage ripple compliant with the application requirements.

The amount of the voltage ripple can be calculated starting from the current ripple obtained by the inductor selection.

Equation 9

$$\Delta V_{\text{OUT}} = \text{ESR} \cdot \Delta I_{\text{MAX}} + \frac{\Delta I_{\text{MAX}}}{8 \cdot C_{\text{OUT}} \cdot f_{\text{SW}}}$$

Usually the resistive component of the ripple is much higher than the capacitive one, if the output capacitor adopted is not a multi layer ceramic capacitor (MLCC) with very low ESR value.

The output capacitor is important also for loop stability: it fixes the double LC filter pole and the zero due to its ESR. In [Chapter 5.4](#), it will be illustrated how to consider its effect in the system stability.

For example with $V_{\text{OUT}}=3.3\text{V}$, $V_{\text{IN}}=12\text{V}$, $\Delta I_{\text{L}}=0.3\text{A}$ (resulting by the inductor value), in order to have a $\Delta V_{\text{OUT}}=0.01 \cdot V_{\text{OUT}}$, if the multi layer capacitor are adopted, 10 μF are needed and the ESR effect on the output voltage ripple can be neglected. In case of not negligible ESR (electrolytic or tantalum capacitors), the capacitor is chosen taking into account its ESR value. So 100 μF with $\text{ESR}=40\text{m}\Omega$ is compliant with the requested output voltage ripple.

The output capacitor is also important to sustain the output voltage when a load transient with high slew rate is required by the load. When the load transient slew rate exceeds the system bandwidth the output capacitor provides the current to the load. So if the high slew rate load transient is required by the application the output capacitor and system bandwidth have to be chosen in order to sustain the load transient .

In the table below some capacitor series are listed.

Table 7. Output capacitors

Manufacturer	Series	Cap value (μF)	Rated voltage (V)	ESR ($\text{m}\Omega$)
MURATA	GRM32	22 to 100	6.3 to 25	< 5
	GRM31	10 to 47	6.3 to 25	< 5

Table 7. Output capacitors

Manufacturer	Series	Cap value (μF)	Rated voltage (V)	ESR ($\text{m}\Omega$)
PANASONIC	ECJ	10 to 22	6.3	< 5
	EEFCD	10 to 68	6.3	15 to 55
SANYO	TPA/B/C	100 to 470	4 to 16	40 to 80
TDK	C3225	22 to 100	6.3	< 5

5.4 Compensation network

The compensation network has to assure stability and good dynamic performance. The loop of the L5981 is based on the voltage mode control. The Error Amplifier is a voltage operational amplifier with high bandwidth. So selecting the compensation network the E/A will be considered as ideal, that is, its bandwidth is much larger than the system one.

The transfer functions of PWM modulator and the output LC filter are studied (see). The transfer function of the PWM modulator, from the Error Amplifier output (COMP pin) to the OUT pin, results:

Equation 10

$$G_{PW0} = \frac{V_{IN}}{V_s}$$

where V_s is the sawtooth amplitude. As seen in [Chapter 4.1](#), the voltage feed forward generates a sawtooth amplitude directly proportional to the input voltage, that is:

Equation 11

$$V_s = K \cdot V_{IN}$$

In this way the PWM modulator gain results constant and equals to:

Equation 12

$$G_{PW0} = \frac{V_{IN}}{V_s} = \frac{1}{K} = 9$$

The synchronization of the device with an external clock provided through SYNCH pin can modify the PWM modulator gain (see [Chapter 4.1](#) to understand how this gain changes and how to keep it constant in spite of the external synchronization).

Figure 9. The error amplifier, the PWM modulator and the LC output filter.

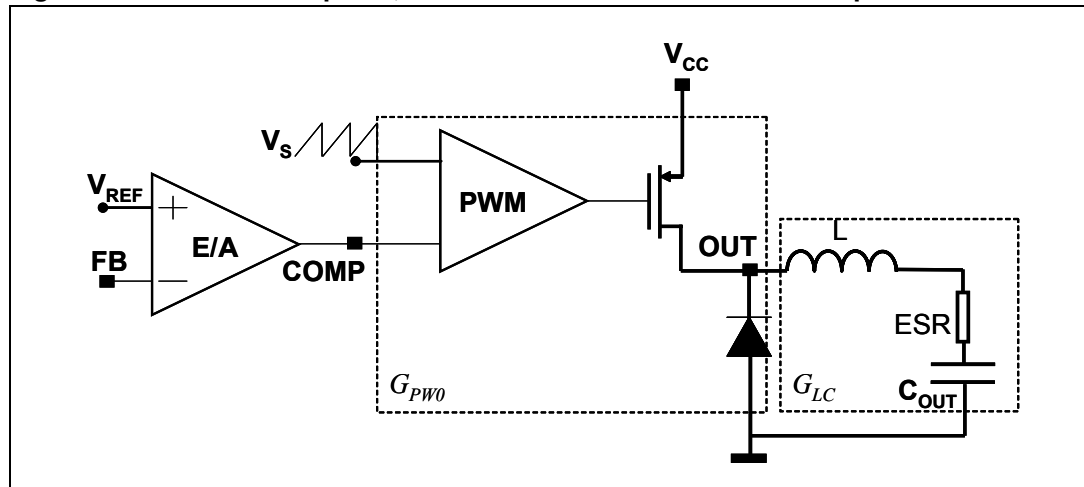

The transfer function on the LC filter is given by:

Equation 13

$$G_{LC}(s) = \frac{1 + \frac{s}{2\pi \cdot f_{zESR}}}{1 + \frac{s}{2\pi \cdot Q \cdot f_{LC}} + \left(\frac{s}{2\pi \cdot f_{LC}}\right)^2}$$

where:

Equation 14

$$f_{LC} = \frac{1}{2\pi \cdot \sqrt{L \cdot C_{OUT}} \cdot \sqrt{1 + \frac{ESR}{R_{OUT}}}}, \quad f_{zESR} = \frac{1}{2\pi \cdot ESR \cdot C_{OUT}}$$

Equation 15

$$Q = \frac{\sqrt{R_{OUT} \cdot L \cdot C_{OUT} \cdot (R_{OUT} + ESR)}}{L + C_{OUT} \cdot R_{OUT} \cdot ESR}, \quad R_{OUT} = \frac{V_{OUT}}{I_{OUT}}$$

As seen in [Chapter 4.3](#) two different kind of network can compensate the loop. In the two following paragraph the guidelines to select the Type II and Type III compensation network are illustrated.

5.4.1 Type III compensation network

The methodology to stabilize the loop consists of placing two zeros to compensate the effect of the LC double pole, so increasing phase margin; then to place one pole in the origin to

minimize the dc error on regulated output voltage; finally to place other poles far away the zero dB frequency.

In *Figure 10* the type III compensation network is shown. This network introduces two zeros (f_{z1}, f_{z2}) and three poles (f_{p0}, f_{p1}, f_{p2}). They expression are:

Equation 16

$$f_{z1} = \frac{1}{2\pi \cdot C_3 \cdot (R_1 + R_3)}, \quad f_{z2} = \frac{1}{2\pi \cdot R_4 \cdot C_4}$$

Equation 17

$$f_{p0} = 0, \quad f_{p1} = \frac{1}{2\pi \cdot R_3 \cdot C_3}, \quad f_{p2} = \frac{1}{2\pi \cdot R_4 \cdot \frac{C_4 \cdot C_5}{C_4 + C_5}}$$

Figure 10. Type III compensation network

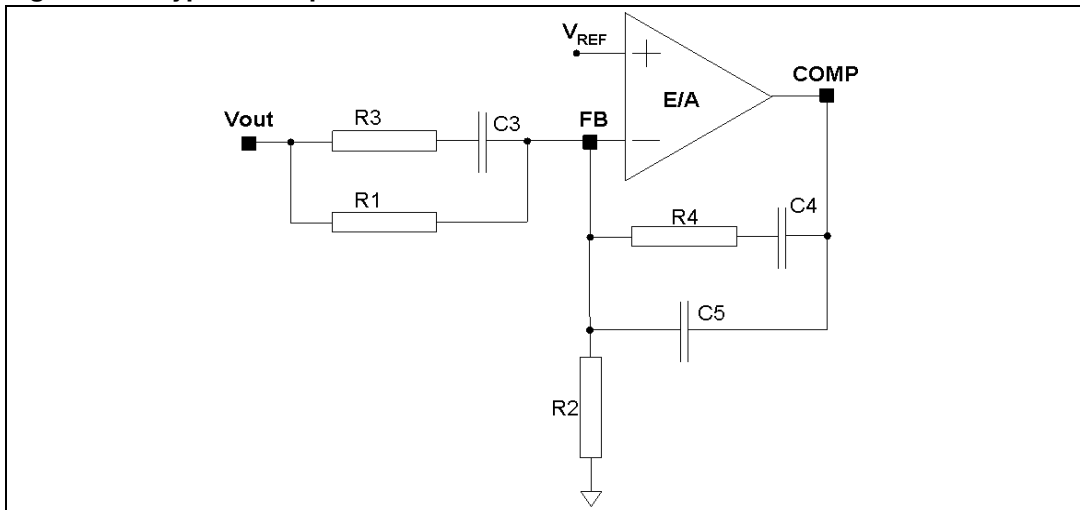

In *Figure 11* the Bode diagram of the PWM and LC filter transfer function ($G_{PW0} \cdot G_{LC}(f)$) and the open loop gain ($G_{LOOP}(f) = G_{PW0} \cdot G_{LC}(f) \cdot G_{TYPEIII}(f)$) are drawn.

Figure 11. Open loop gain: module Bode diagram

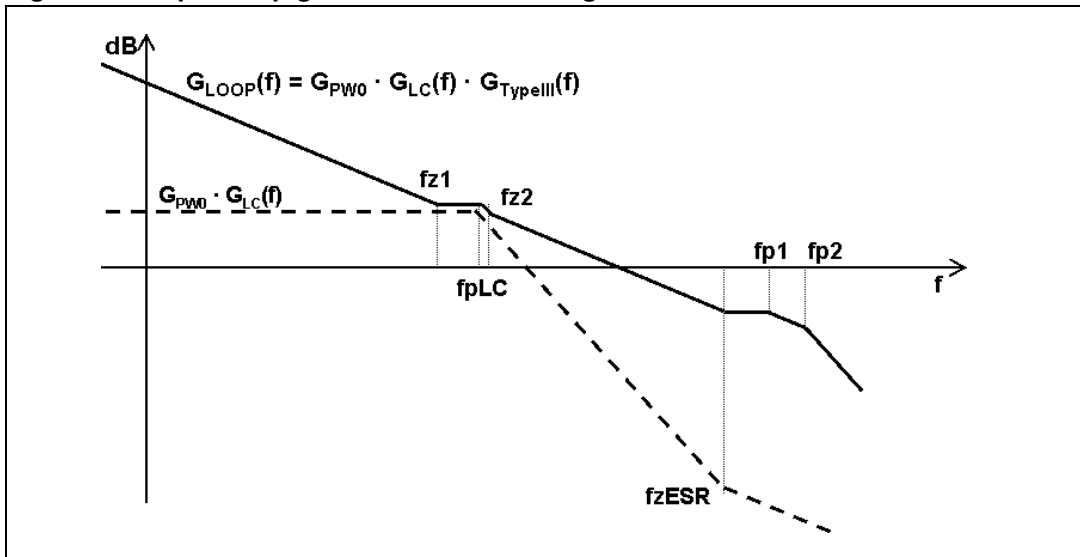

The guidelines for positioning the poles and the zeroes and for calculating the component values can be summarized as follow:

1. Choose a value for R_1 , usually between 1k and 5k.
2. Choose a gain (R_4/R_1) in order to have the required bandwidth (BW), that means:

Equation 18

$$R_4 = \frac{BW}{f_{LC}} \cdot \frac{1}{K} \cdot R_1$$

where K is the feed forward constant and 1/K is equals to 9.

3. Calculate C_4 by placing the zero at 50% of the output filter double pole frequency (f_{LC}):

Equation 19

$$C_4 = \frac{1}{\pi \cdot R_4 \cdot f_{LC}}$$

4. Calculate C_5 by placing the second pole at four times the system bandwidth (BW):

Equation 20

$$C_5 = \frac{C_4}{2\pi \cdot R_4 \cdot C_4 \cdot 4 \cdot BW - 1}$$

5. Set also the first pole at four times the system bandwidth and also the second zero at the output filter double pole:

Equation 21

$$R_3 = \frac{R_1}{\frac{4 \cdot BW}{f_{LC}} - 1}, \quad C_3 = \frac{1}{2\pi \cdot R_3 \cdot 4 \cdot BW}$$

The suggested maximum system bandwidth is equals to the switching frequency divided by 3.5 ($F_{SW}/3.5$), anyway lower than 100kHz if the F_{SW} is set higher than 500kHz.

For example with $V_{OUT}=3.3V$, $V_{IN}=12V$, $I_O=1A$, $L=33\mu H$, $C_{OUT}=22\mu F$, the type III compensation network is:

$$R_1 = 4.99k\Omega, \quad R_2 = 1.1k\Omega, \quad R_3 = 110\Omega, \quad R_4 = 5.6k\Omega, \quad C_3 = 4.7nF, \quad C_4 = 10nF, \quad C_5 = 100pF$$

In [Figure 12](#) is shown the module and phase of the open loop gain. The bandwidth is about 56kHz and the phase margin is 53°.

Figure 12. Open loop gain bode diagram with ceramic output capacitor

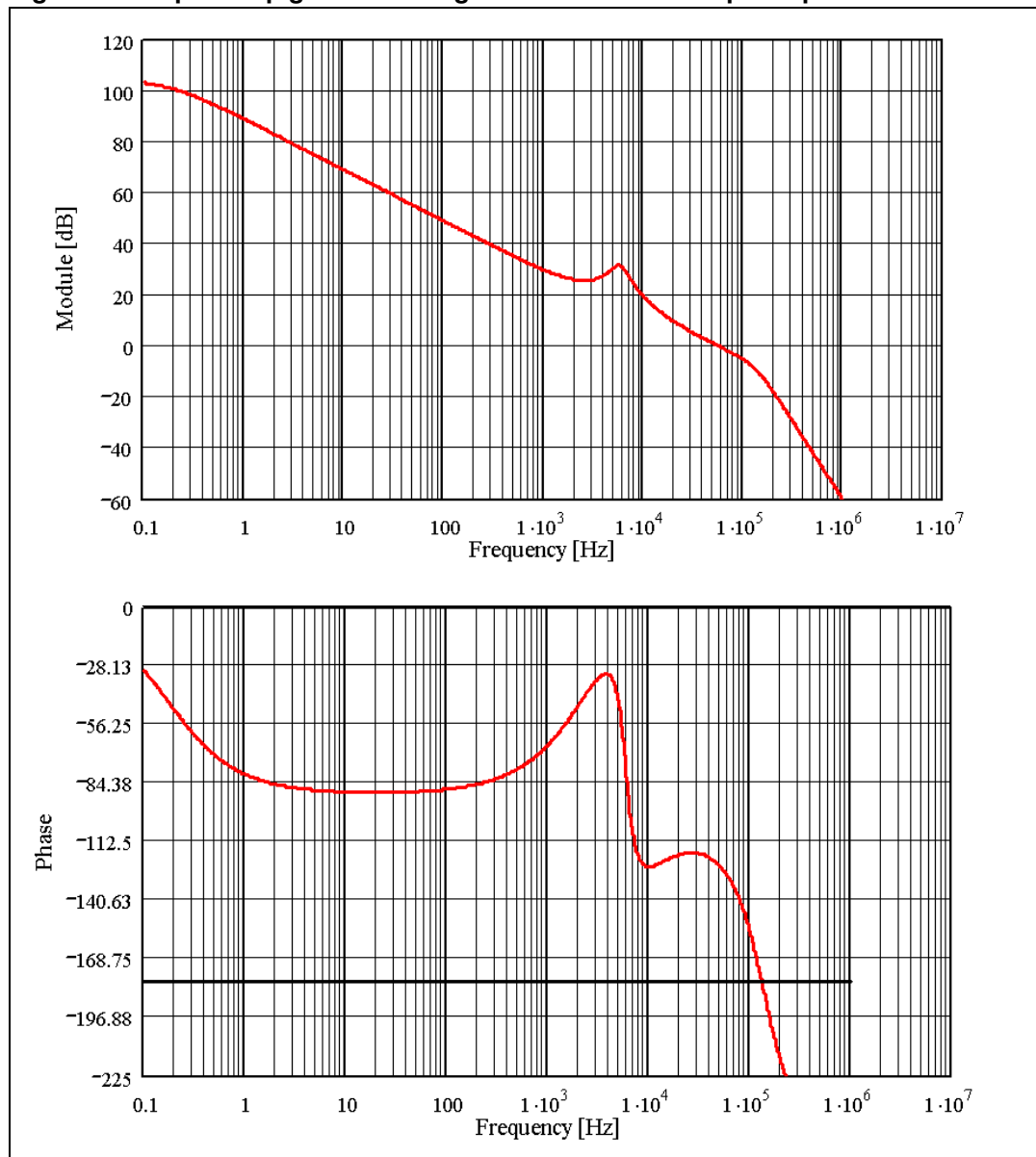

5.4.2 Type II compensation network

In [Figure 13](#) the type II network is shown.

Figure 13. Type II compensation network

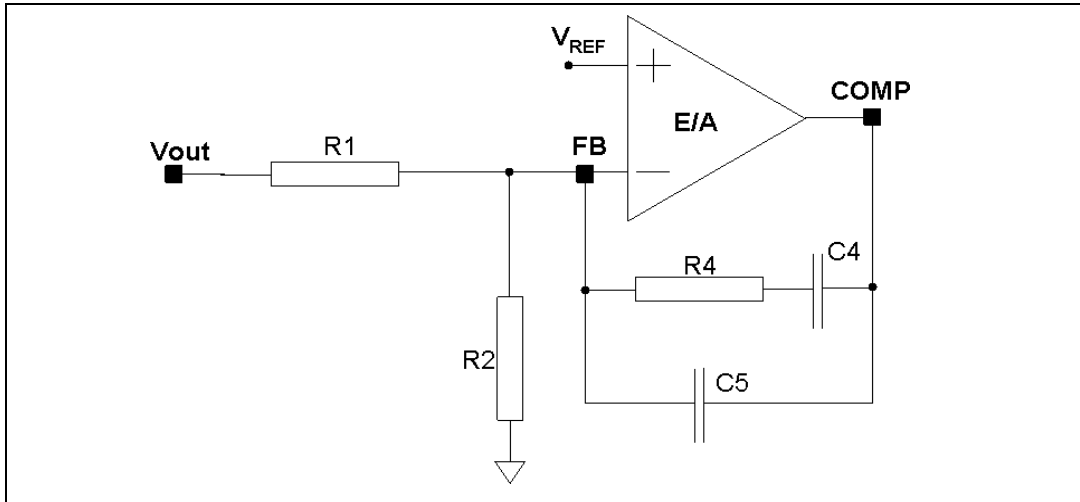

The singularity of the network are:

$$f_{z1} = \frac{1}{2\pi \cdot R_4 \cdot C_4}, \quad f_{p0} = 0, \quad f_{p1} = \frac{1}{2\pi \cdot R_4 \cdot \frac{C_4 \cdot C_5}{C_4 + C_5}}$$

In [Figure 14](#) the Bode diagram of the PWM and LC filter transfer function ($G_{PW0} \cdot G_{LC}(f)$) and the open loop gain ($G_{LOOP}(f) = G_{PW0} \cdot G_{LC}(f) \cdot G_{TYPEII}(f)$) are drawn.

Figure 14. Open loop gain: module bode diagram

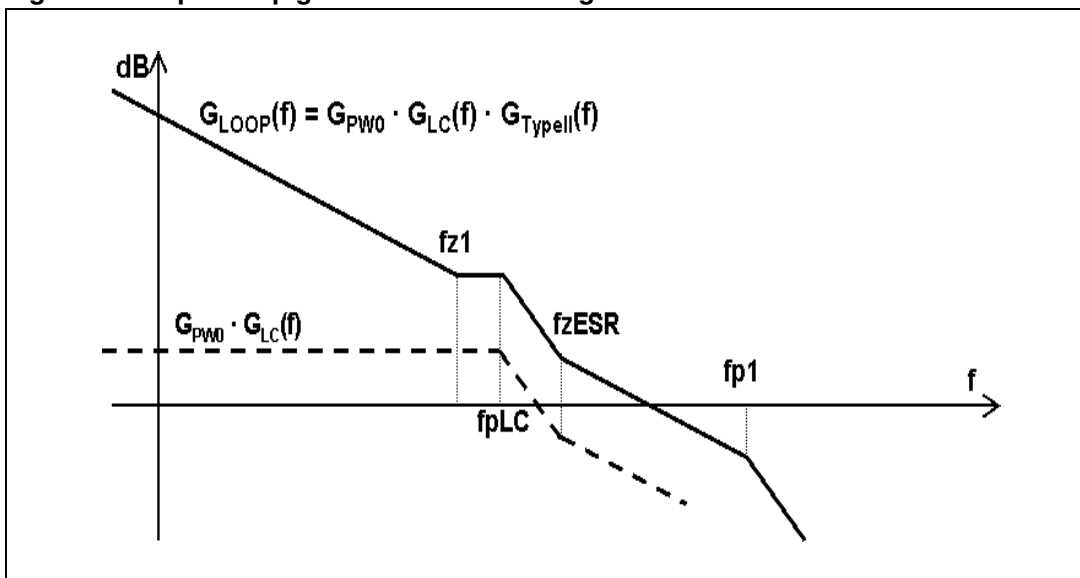

The guidelines for positioning the poles and the zeroes and for calculating the component values can be summarized as follow:

1. Choose a value for R_1 , usually between 1k and 5k, in order to have values of C_4 and C_5 not comparable with parasitic capacitance of the board.
2. Choose a gain (R_4/R_1) in order to have the required bandwidth (BW), that means:

Equation 22

$$R_4 = \left(\frac{f_{ESR}}{f_{LC}} \right)^2 \cdot \frac{BW}{f_{ESR}} \cdot \frac{V_S}{V_{IN}} \cdot R_1$$

Where f_{ESR} is the ESR zero:

Equation 23

$$f_{ESR} = \frac{1}{2\pi \cdot ESR \cdot C_{OUT}}$$

and V_S is the saw-tooth amplitude. The voltage feed forward keeps the ratio V_S/V_{IN} constant.

3. Calculate C_4 by placing the zero one decade below the output filter double pole:

Equation 24

$$C_4 = \frac{10}{2\pi \cdot R_4 \cdot f_{LC}}$$

4. Then calculate C_3 in order to place the second pole at four times the system bandwidth (BW):

Equation 25

$$C_5 = \frac{C_4}{2\pi \cdot R_4 \cdot C_4 \cdot 4 \cdot BW - 1}$$

For example with $V_{OUT}=3.3V$, $V_{IN}=12V$, $I_O=1A$, $L=33\mu H$, $C_{OUT}=220\mu F$, $ESR=100m\Omega$, the type II compensation network is:

$$R_1 = 1.1k\Omega, \quad R_2 = 249\Omega, \quad R_4 = 10k\Omega, \quad C_4 = 10nF, \quad C_5 = 100pF$$

In [Figure 15](#) is shown the module and phase of the open loop gain. The bandwidth is about 33kHz and the phase margin is 46°.

Figure 15. Open loop gain bode diagram with electrolytic/tantalum output capacitor

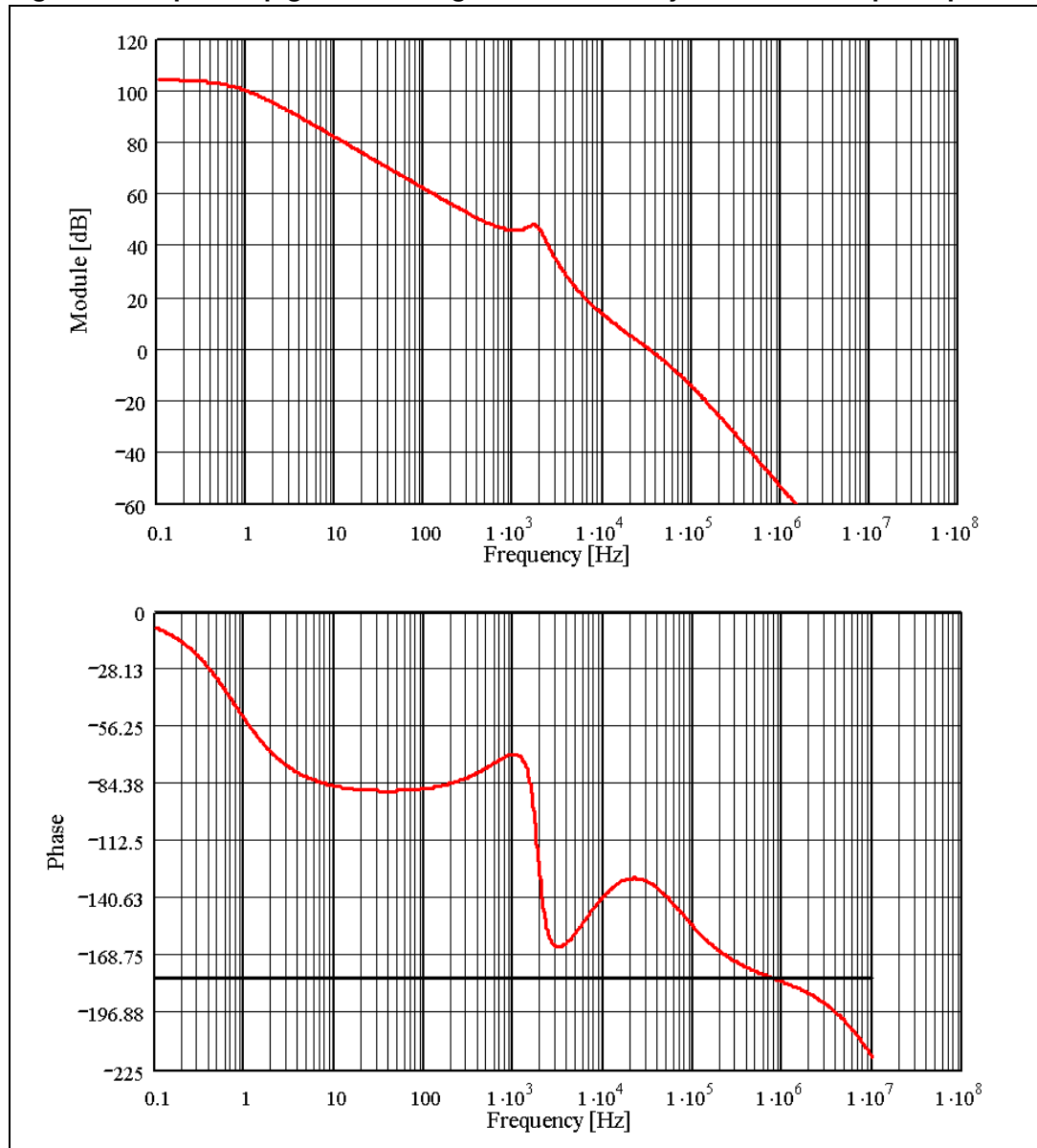

5.5 Thermal considerations

The thermal design is important to prevent the thermal shutdown of device if junction temperature goes above 150°C. The three different sources of losses within the device are:

- a) conduction losses due to the not negligible R_{DSON} of the power switch; these are equal to:

Equation 26

$$P_{\text{ON}} = R_{\text{DSON}} \cdot (I_{\text{OUT}})^2 \cdot D$$

Where D is the duty cycle of the application and the maximum R_{DSON} is 300mΩ. Note that the duty cycle is theoretically given by the ratio between V_{OUT} and V_{IN} , but actually it is quite higher to compensate the losses of the regulator. So the conduction losses increases compared with the ideal case.

- b) switching losses due to power MOSFET turn ON and OFF; these can be calculated as:

Equation 27

$$P_{\text{SW}} = V_{\text{IN}} \cdot I_{\text{OUT}} \cdot \frac{(T_{\text{RISE}} + T_{\text{FALL}})}{2} \cdot F_{\text{SW}} = V_{\text{IN}} \cdot I_{\text{OUT}} \cdot T_{\text{SW}} \cdot F_{\text{SW}}$$

Where T_{RISE} and T_{FALL} are the overlap times of the voltage across the power switch (V_{DS}) and the current flowing into it during turn ON and turn OFF phases, as shown in [Figure 16](#). T_{SW} is the equivalent switching time. For this device the typical value for the equivalent switching time is 50ns.

- c) Quiescent current losses, calculated as:

Equation 28

$$P_{\text{Q}} = V_{\text{IN}} \cdot I_{\text{Q}}$$

where I_{Q} is the quiescent current ($I_{\text{Q}}=20\mu\text{A}$).

The junction temperature T_{J} can be calculated as:

Equation 29

$$T_{\text{J}} = T_{\text{A}} + R_{\text{thJA}} \cdot P_{\text{TOT}}$$

Where T_{A} is the ambient temperature and P_{TOT} is the sum of the power losses just seen.

R_{thJA} is the equivalent thermal resistance junction to ambient of the device; it can be calculated as the parallel of many paths of heat conduction from the junction to the ambient. For this device the path through the exposed pad is the one conducting the largest amount

of heat. The R_{thJA} measured on the demoboard described in the following paragraph is about $60^{\circ}/W$.

Figure 16. Switching losses

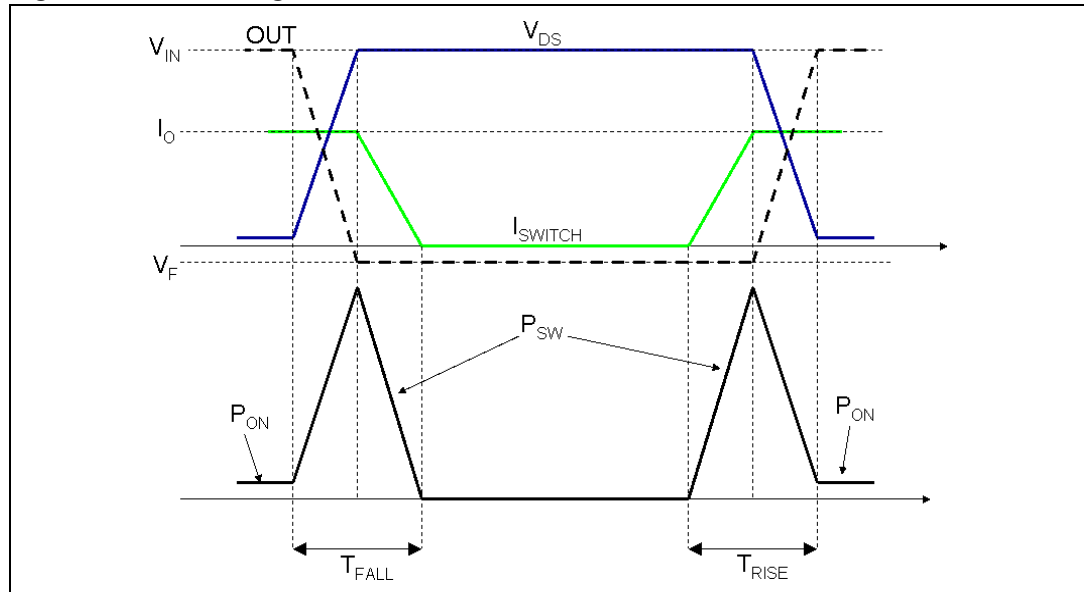

5.6 Layout considerations

The PC board layout of switching DC/DC regulator is very important to minimize the noise injected in high impedance nodes and interferences generated by the high switching current loops.

In a step down converter the input loop (including the input capacitor, the power MOSFET and the free wheeling diode) is the most critical one. This is due to the fact that the high value pulsed current are flowing through it. In order to minimize the EMI, this loop has to be as short as possible.

The feedback pin (FB) connection to external resistor divider is a high impedance node, so the interferences can be minimized placing the routing of feedback node as far as possible from the high current paths. To reduce the pick up noise the resistor divider has to be placed very close to the device.

To filter the high frequency noise, a small capacitor can be added as close as possible to the input voltage pin of the device.

Thanks to the exposed pad of the device, the ground plane helps to reduce the thermal resistance junction to ambient; so a large ground plane enhances the thermal performance of the converter allowing high power conversion.

In [Figure 17](#) a layout example is shown.

Figure 17. Layout example

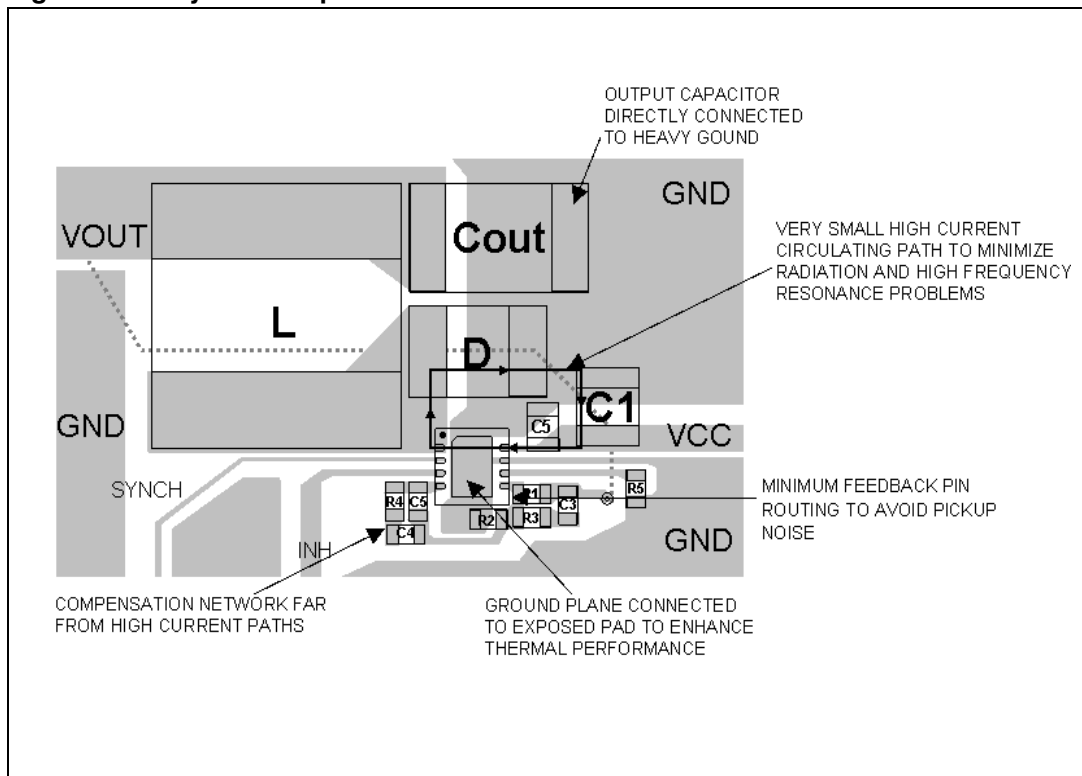

5.7 Application circuit

In [Figure 18](#) the demo board application circuit is shown.

Figure 18. Demo board application circuit

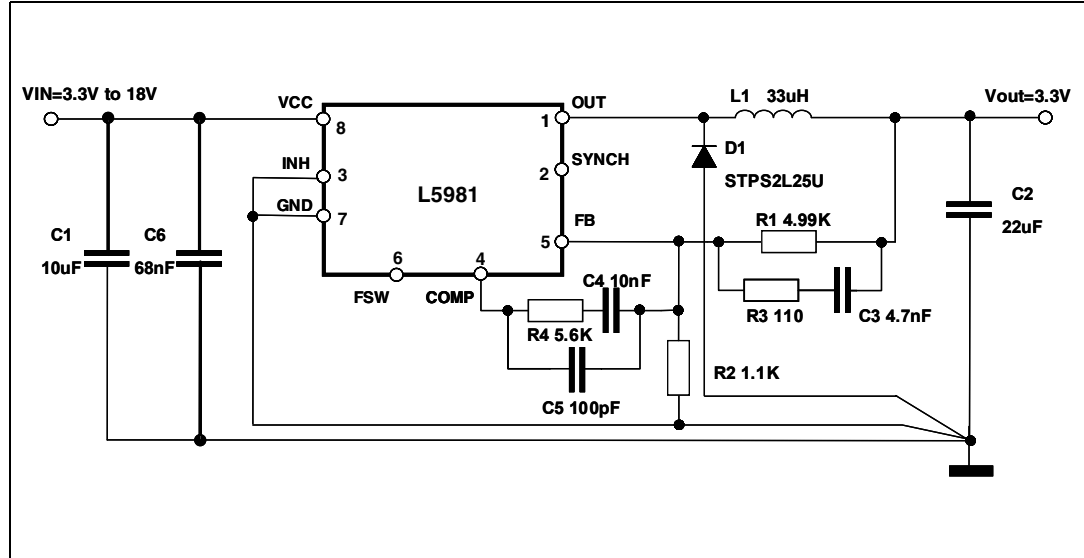

Table 8. Component list

Reference	Part number	Description	Manufacturer
C1	GRM31CR61E106KA12	10µF, 25V	Murata
C2	GRM32ER61E226KE15	22µF, 25V	Murata
C3		4.7nF, 50V	
C4		10nF, 50V	
C5		100pF, 50V	
C6		68nF, 25V	
R1		4.99 kΩ, 1%, 0.1W 0603	
R2		1.1kΩ, 1%, 0.1W 0603	
R3		110 Ω, 1%, 0.1W 0603	
R4		5.6 kΩ, 1%, 0.1W 0603	
R5		n.c.	
D1	STPS2L25V	2A, 25V	STMicroelectronics
L1	744066330	33µH, 30%, 2.9A	Würth Elektronik

Figure 19. PCB layout (component side)

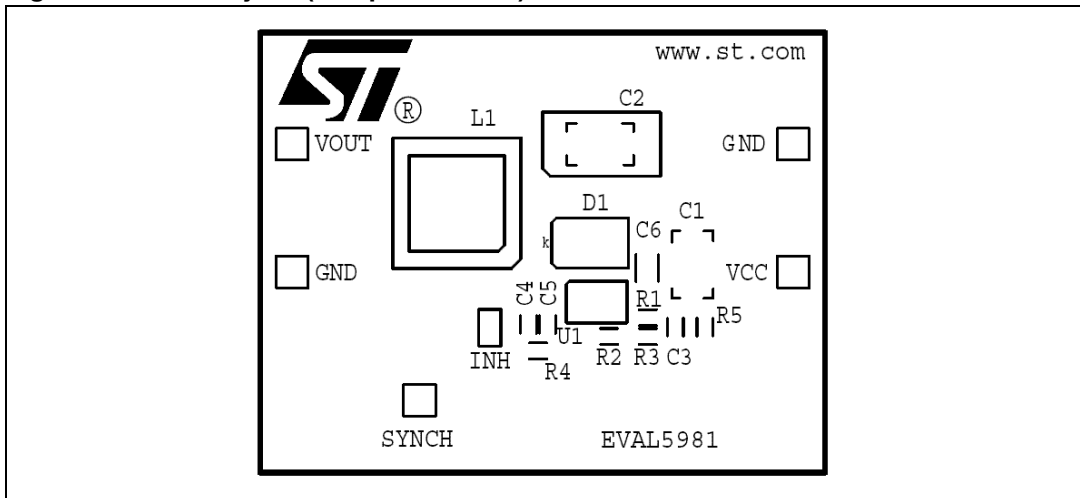

Figure 20. PCB layout (bottom side)

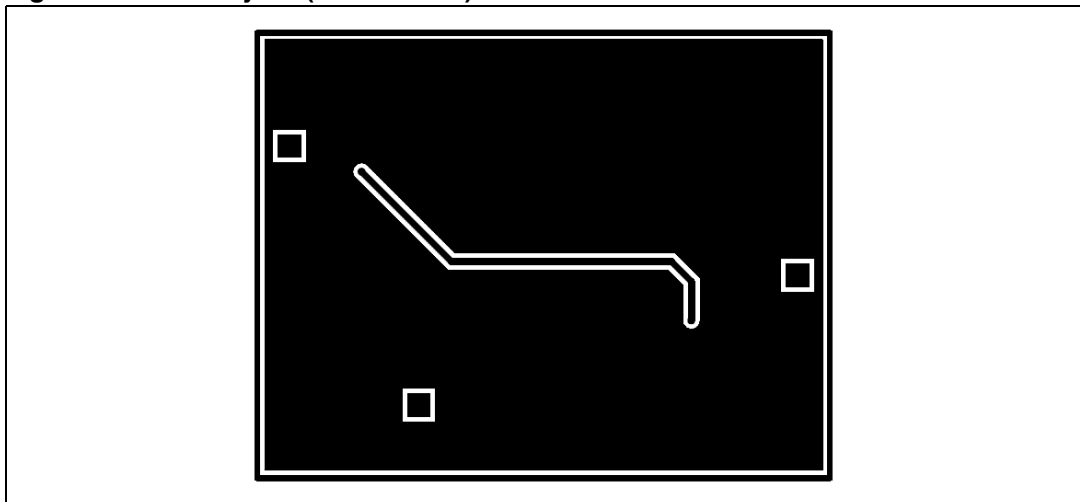

Figure 21. PCB layout (front side)

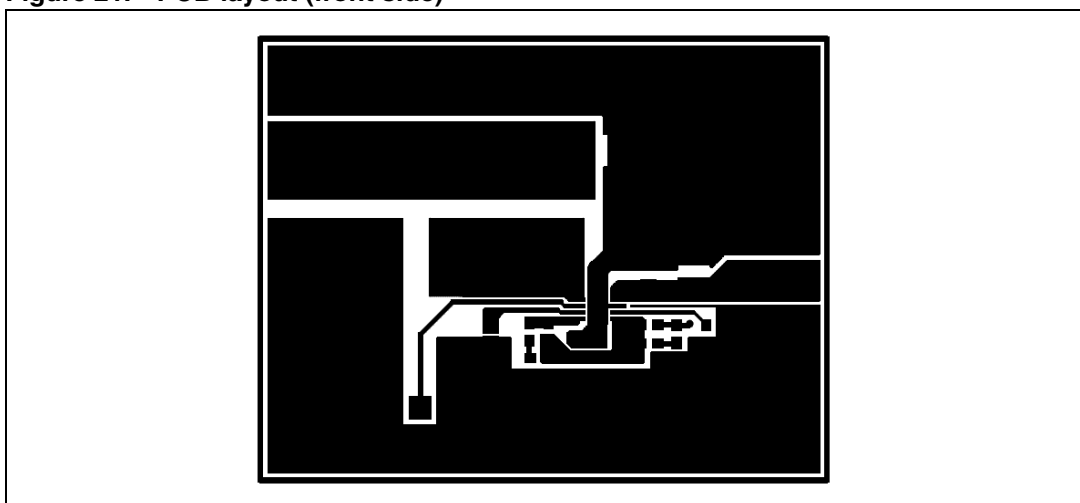

Figure 22. Junction temperature vs output current

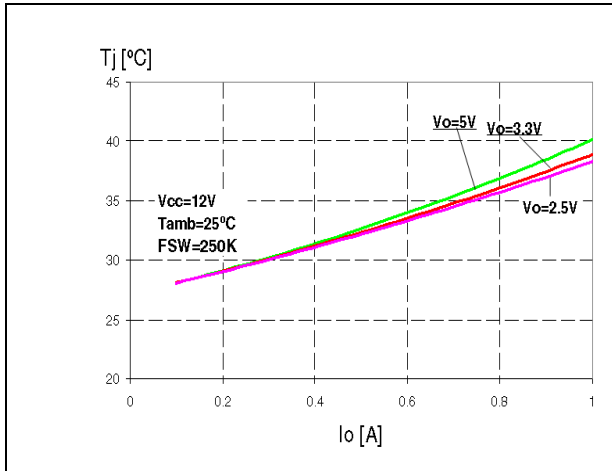

Figure 25. Efficiency vs output current

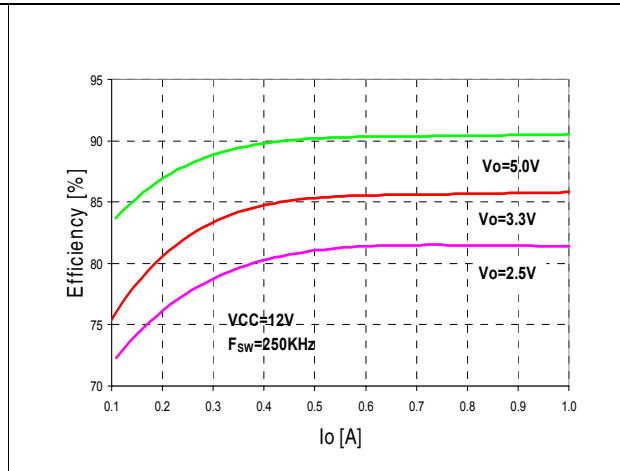

Figure 23. Junction temperature vs output current

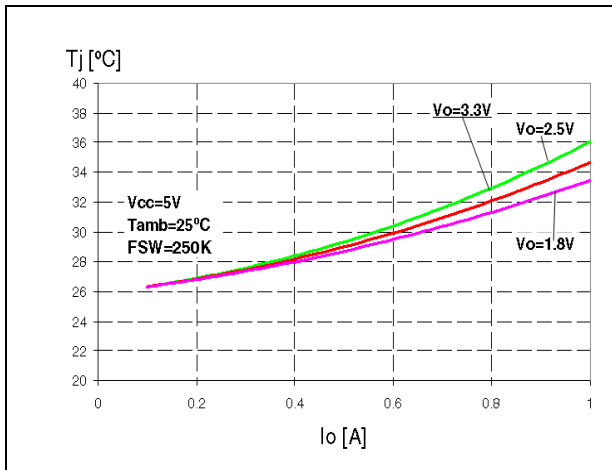

Figure 26. Efficiency vs output current

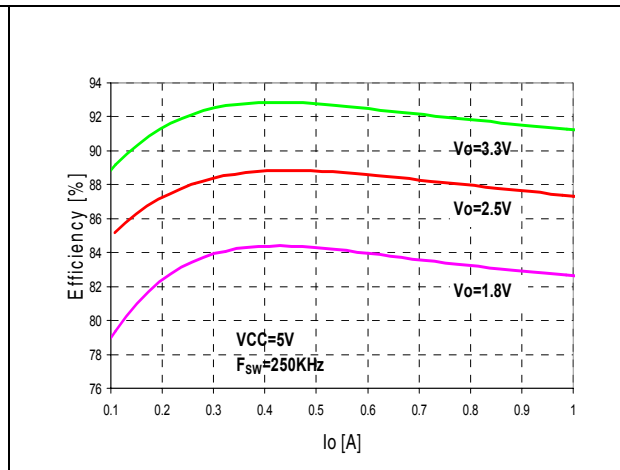

Figure 24. Junction temperature vs output current

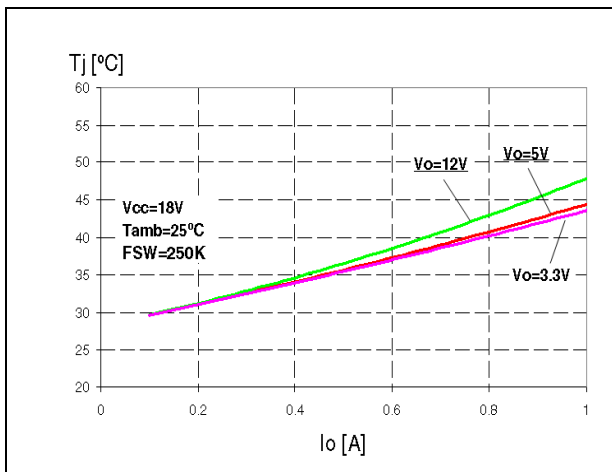

Figure 27. Efficiency vs output current

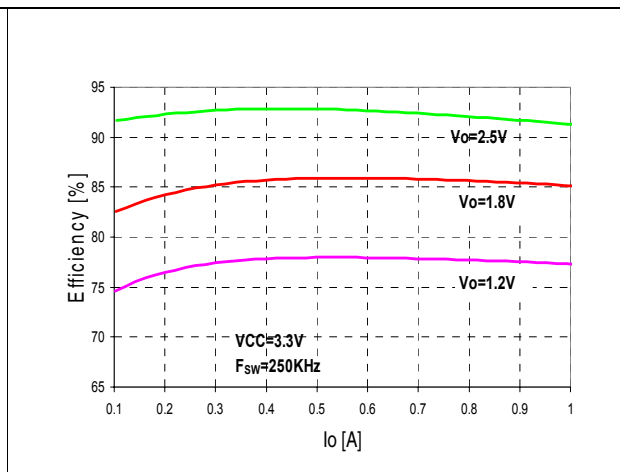

Figure 28. Load regulation

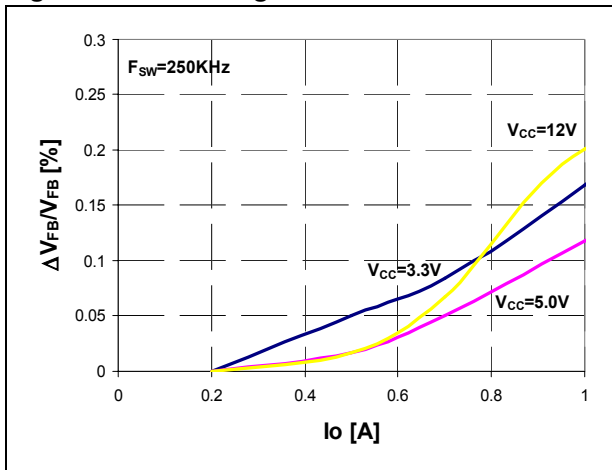

Figure 31. Soft start

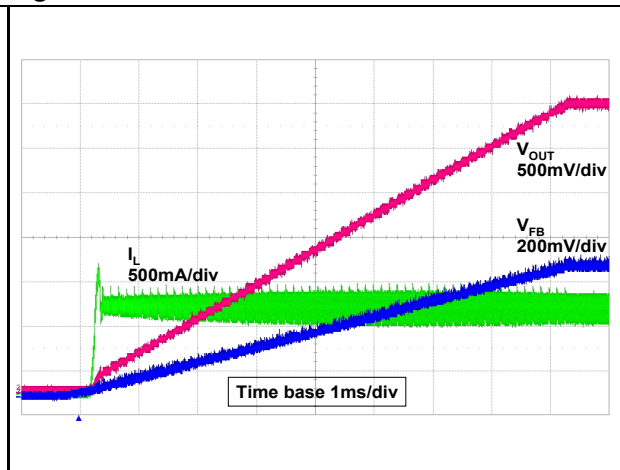

Figure 29. Line regulation

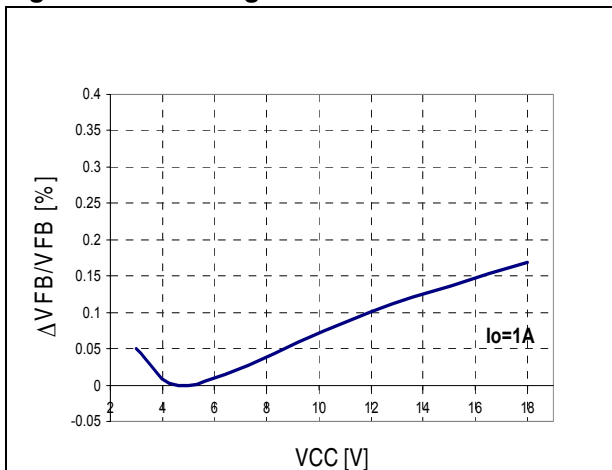

Figure 32. Short circuit behavior

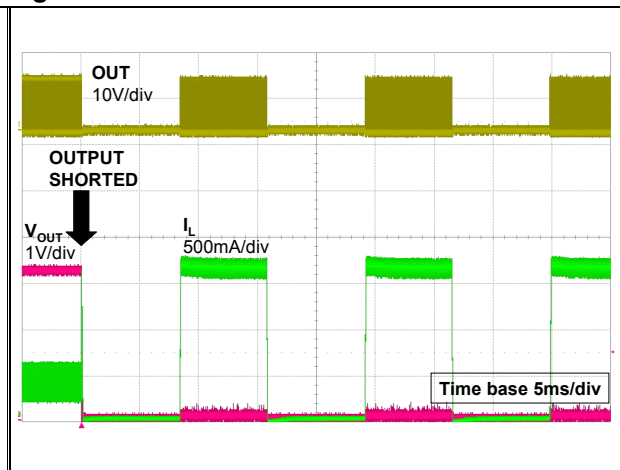
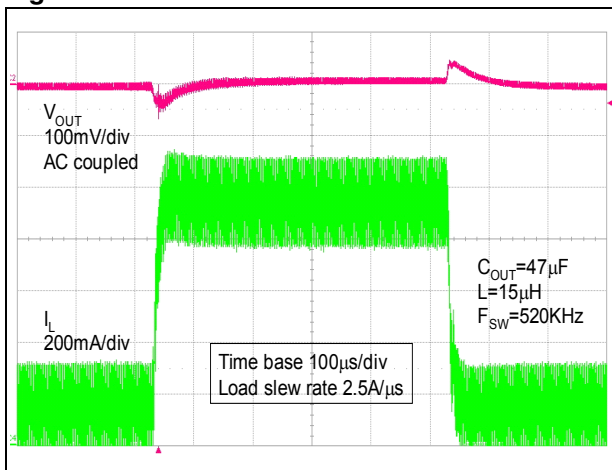

Figure 30. Load transient: from 0.2A to 1A



6 Package mechanical data

In order to meet environmental requirements, ST offers these devices in ECOPACK® packages. These packages have a Lead-free second level interconnect. The category of the second level interconnect is marked on the package and on the inner box label, in compliance with the JEDEC Standard JESD97. The maximum ratings related to soldering condition are also marked on the inner box label. ECOPACK® is an ST trademark.

ECOPACK specifications are available at: www.st.com

Table 9. VFQFPN8 (3x3x1.08mm) mechanical data

Dim.	mm			inch		
	Min	Typ	Max	Min	Typ	Max
A	0.80	0.90	1.00	0.0315	0.0354	0.0394
A1		0.02	0.05		0.0008	0.0020
A2		0.70			0.0276	
A3		0.20			0.0079	
b	0.18	0.23	0.30	0.0071	0.0091	0.0118
D		3.00			0.1181	
D2	2.23	2.38	2.48	0.0878	0.0937	0.0976
E		3.00			0.1181	
E2	1.49	1.64	1.74	0.0587	0.0646	0.0685
e		0.50			0.0197	
L	0.30	0.40	0.50	0.0118	0.0157	0.0197
ddd			0.08			0.0031

Figure 33. Package dimensions

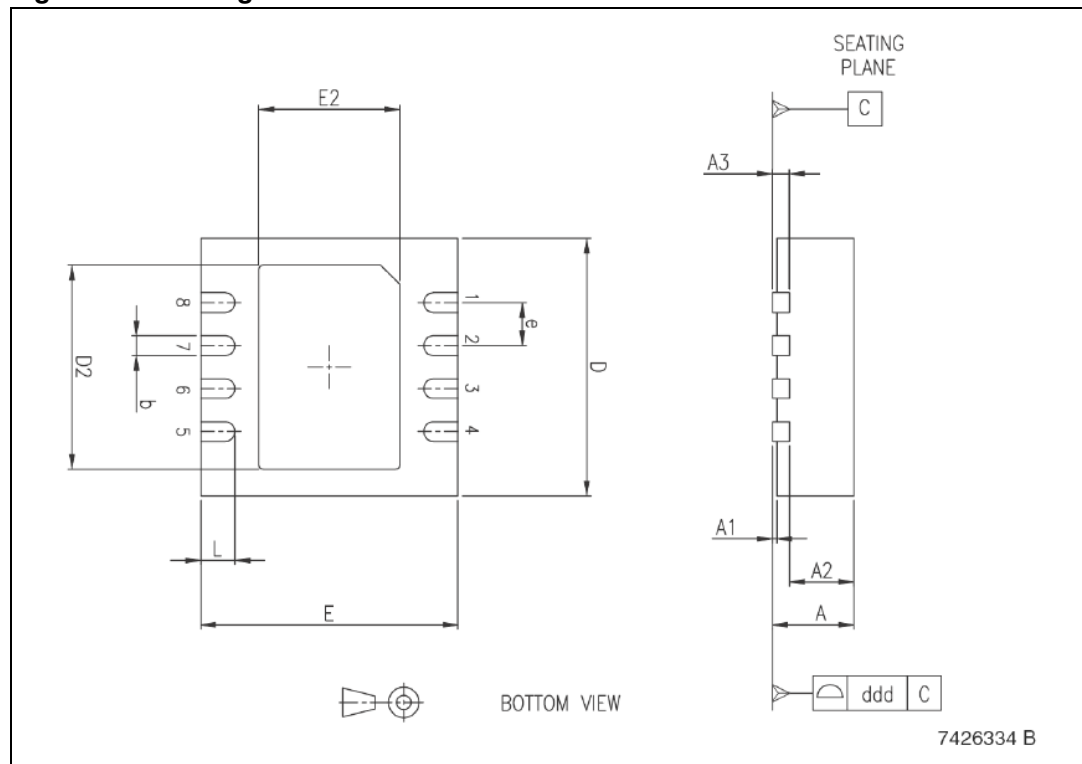

7426334 B

7 Order codes

Table 10. Order codes

Order codes	Package	Packaging
L5981	VFQFPN8 (3x3x1.08)	Tube
L5981TR	VFQFPN8 (3x3x1.08)	Tube and reel

8 Revision history

Table 11. Document revision history

Date	Revision	Changes
21-Dec-2006	1	Initial release
16-Oct-2007	2	Document status promoted from preliminary data to datasheet

Please Read Carefully:

Information in this document is provided solely in connection with ST products. STMicroelectronics NV and its subsidiaries ("ST") reserve the right to make changes, corrections, modifications or improvements, to this document, and the products and services described herein at any time, without notice.

All ST products are sold pursuant to ST's terms and conditions of sale.

Purchasers are solely responsible for the choice, selection and use of the ST products and services described herein, and ST assumes no liability whatsoever relating to the choice, selection or use of the ST products and services described herein.

No license, express or implied, by estoppel or otherwise, to any intellectual property rights is granted under this document. If any part of this document refers to any third party products or services it shall not be deemed a license grant by ST for the use of such third party products or services, or any intellectual property contained therein or considered as a warranty covering the use in any manner whatsoever of such third party products or services or any intellectual property contained therein.

UNLESS OTHERWISE SET FORTH IN ST'S TERMS AND CONDITIONS OF SALE ST DISCLAIMS ANY EXPRESS OR IMPLIED WARRANTY WITH RESPECT TO THE USE AND/OR SALE OF ST PRODUCTS INCLUDING WITHOUT LIMITATION IMPLIED WARRANTIES OF MERCHANTABILITY, FITNESS FOR A PARTICULAR PURPOSE (AND THEIR EQUIVALENTS UNDER THE LAWS OF ANY JURISDICTION), OR INFRINGEMENT OF ANY PATENT, COPYRIGHT OR OTHER INTELLECTUAL PROPERTY RIGHT.

UNLESS EXPRESSLY APPROVED IN WRITING BY AN AUTHORIZED ST REPRESENTATIVE, ST PRODUCTS ARE NOT RECOMMENDED, AUTHORIZED OR WARRANTED FOR USE IN MILITARY, AIR CRAFT, SPACE, LIFE SAVING, OR LIFE SUSTAINING APPLICATIONS, NOR IN PRODUCTS OR SYSTEMS WHERE FAILURE OR MALFUNCTION MAY RESULT IN PERSONAL INJURY, DEATH, OR SEVERE PROPERTY OR ENVIRONMENTAL DAMAGE. ST PRODUCTS WHICH ARE NOT SPECIFIED AS "AUTOMOTIVE GRADE" MAY ONLY BE USED IN AUTOMOTIVE APPLICATIONS AT USER'S OWN RISK.

Resale of ST products with provisions different from the statements and/or technical features set forth in this document shall immediately void any warranty granted by ST for the ST product or service described herein and shall not create or extend in any manner whatsoever, any liability of ST.

ST and the ST logo are trademarks or registered trademarks of ST in various countries.

Information in this document supersedes and replaces all information previously supplied.

The ST logo is a registered trademark of STMicroelectronics. All other names are the property of their respective owners.

© 2007 STMicroelectronics - All rights reserved

STMicroelectronics group of companies

Australia - Belgium - Brazil - Canada - China - Czech Republic - Finland - France - Germany - Hong Kong - India - Israel - Italy - Japan - Malaysia - Malta - Morocco - Singapore - Spain - Sweden - Switzerland - United Kingdom - United States of America

www.st.com