



L3G4IS

MEMS motion sensor: three-axis digital output gyroscope for gaming and OIS

Preliminary data

Features

- Three selectable full-scales (250/500/2000 dps) for gaming applications
- ± 65 dps full-scale for OIS applications
- Independent I²C and SPI digital interfaces
- Embedded temperature sensor
- Integrated low- and high-pass filters with user-selectable bandwidth
- Wide supply voltage range: 2.4 V to 3.6 V
- Low voltage-compatible IOs (1.8 V)
- Power-down and sleep mode for smart power saving
- Embedded FIFO (first-in first-out buffer)
- ECOPACK[®] RoHS and “Green” compliant

Applications

- Gaming and virtual reality input devices
- Optical image stabilization
- Motion control and gesture recognition
- GPS navigation systems

Description

The L3G4IS is the first three-axis MEMS gyroscope that enables both user interface and image stabilization applications at the same time.

Thanks to two different independent reading chains and digital interfaces, the L3G4IS delivers previously unseen levels of flexibility to the end user.

Each reading chain and the corresponding full-

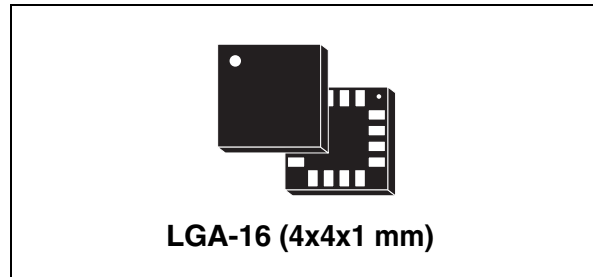

scale can be activated by powering two separate pins, the internal ASIC blocks automatically detect and enable the selected device configuration.

The unique sensing element is manufactured using a dedicated micro-machining process developed by STMicroelectronics to produce inertial sensors and actuators on silicon wafers.

The L3G4IS is available in a plastic land grid array (LGA) package and can operate within a temperature range of -30 °C to +85 °C.

Table 1. Device summary

Order code	Temperature range (°C)	Package	Packing
L3G4IS	-30 to +85	LGA-16 (4x4x1)	Tray
L3G4ISTR	-30 to +85	LGA-16 (4x4x1)	Tape and reel

Contents

- 1 Block diagram and pin description 5**
 - 1.1 Pin description 5
- 2 Terminology 7**
 - 2.1 Sensitivity 7
 - 2.2 Zero-rate level 7
- 3 Working mode selection 8**
- 4 User interface mode specifications 9**
 - 4.1 Mechanical characteristics 9
 - 4.2 Electrical characteristics 10
 - 4.3 Temperature sensor characteristics 11
 - 4.4 Absolute maximum ratings 11
- 5 Image stabilization (OIS mode) specifications 13**
 - 5.1 Mechanical characteristics 13
 - 5.2 Electrical characteristics 14
 - 5.3 Temperature sensor characteristics 14
 - 5.4 Absolute maximum ratings 15
- 6 Application hints 16**
 - 6.1 Power supply configurations 18
 - 6.1.1 Configuration 1 18
 - 6.1.2 Configuration 2 19
 - 6.1.3 Configuration 3 19
 - 6.1.4 Configuration 4 (case use) 20
- 7 Soldering information 21**
- 8 Package information 22**
- 9 Revision history 23**

List of tables

Table 1.	Device summary	1
Table 2.	Pin description	6
Table 3.	Operating mode	8
Table 4.	Mechanical characteristics	9
Table 5.	Electrical characteristics	10
Table 6.	Electrical characteristics	11
Table 7.	Absolute maximum ratings	11
Table 8.	Mechanical characteristics	13
Table 9.	Electrical characteristics	14
Table 10.	Electrical characteristics	14
Table 11.	Absolute maximum ratings	15
Table 12.	External components	16
Table 13.	Document revision history	23

List of figures

Figure 1.	Block diagram	5
Figure 2.	Pin connection	5
Figure 3.	L3G4IS electrical connections and external component values	16
Figure 4.	L3G4IS power supply configuration 1	18
Figure 5.	L3G4IS power supply configuration 2	19
Figure 6.	L3G4IS power supply configuration 3	19
Figure 7.	L3G4IS power supply configuration 4 (case use)	20
Figure 8.	LGA-16: mechanical data and package dimensions	22

1 Block diagram and pin description

Figure 1. Block diagram

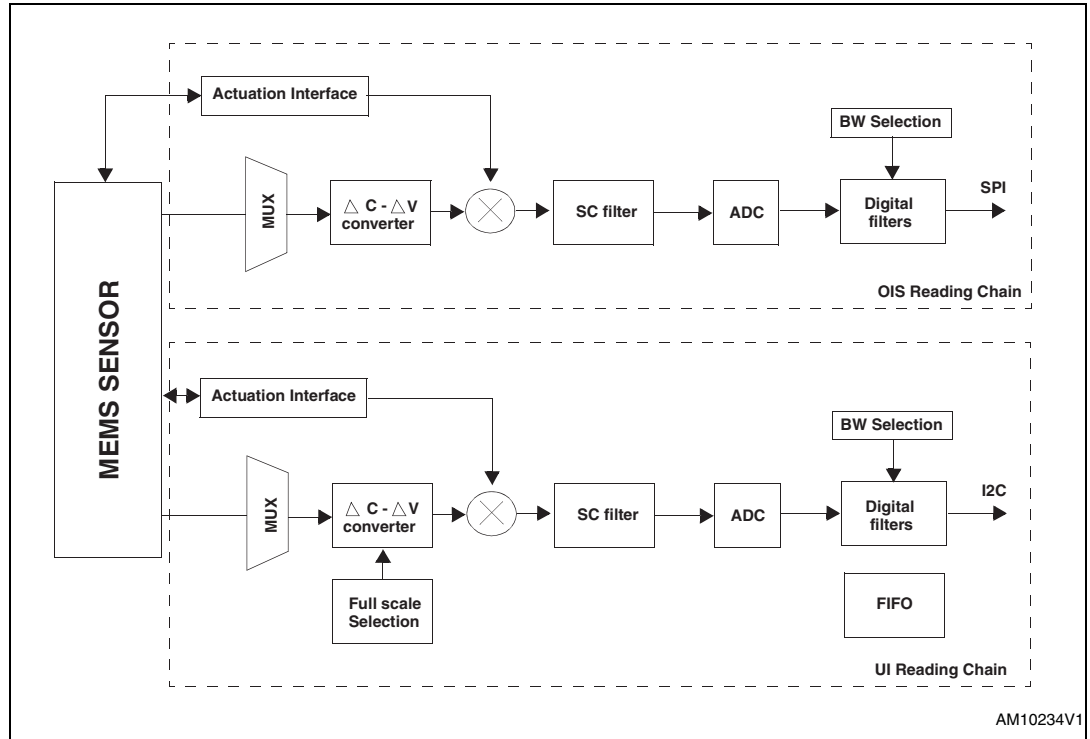

1.1 Pin description

Figure 2. Pin connection

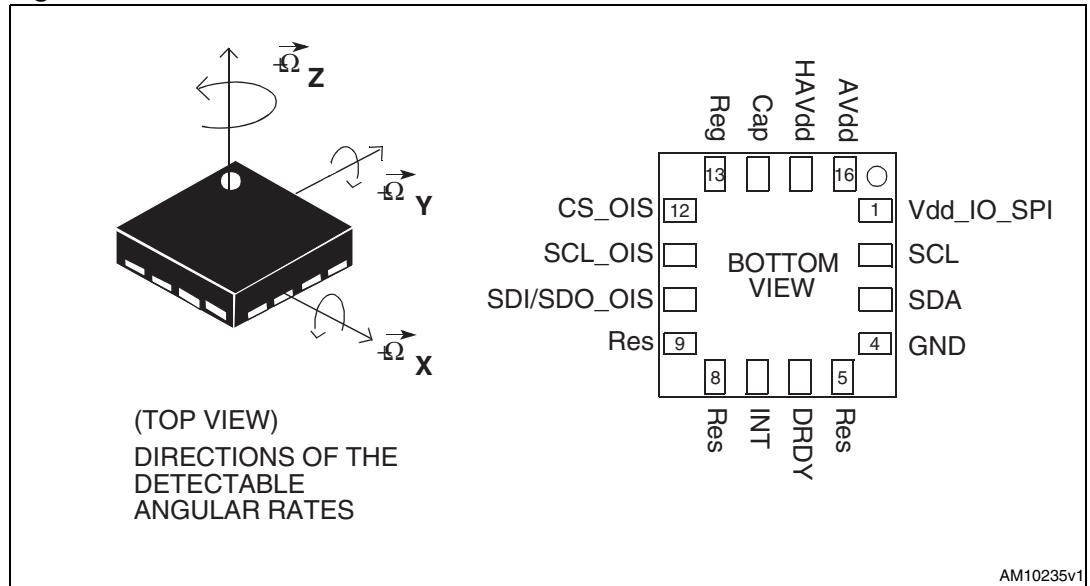

Table 2. Pin description

Pin#	Name	Function
1	Vdd_IO_SPI	Power supply for I/O pins of the PSPI interface
2	SCL	I ² C serial clock (SCL)
3	SDA	I ² C serial data (SDA)
4	GND	0 V power supply
5	Reserved	Leave unconnected
6	DRDY	Data ready signal (open drain pad)
7	INT	Programmable interrupt (open drain pad)
8	Reserved	Leave unconnected
9	Reserved	Leave unconnected
10	SDI/SDO_OIS	Data-in, data-out line for SPI interface
11	SCL_OIS	Clock line for SPI interface
12	CS_OIS	SPI chip select line
13	Reg	Capacitance connection pin for internal regulator
14	Cap	Capacitance connection pin for internal charge pump
15	HAVdd	Power supply for OIS mode
16	AVdd	Power supply for user interface mode

2 Terminology

2.1 Sensitivity

An angular rate gyroscope is a device that produces a positive-going digital output for counter-clockwise rotation around the sensitive axis considered. Sensitivity describes the gain of the sensor and can be determined by applying a defined angular velocity to it. This value changes very little over temperature and time.

2.2 Zero-rate level

Zero-rate level describes the actual output signal if there is no angular rate present. The zero-rate level of precise MEMS sensors is, to some extent, a result of stress to the sensor and therefore the zero-rate level can slightly change after mounting the sensor onto a printed circuit board or after exposing it to extensive mechanical stress. This value changes very little over temperature and time.

3 Working mode selection

The L3G4IS can be used for user interface and image stabilization applications. Depending on the power supply provided and dedicated internal bits configuration, the L3G4IS is able to keep both reading chains active allowing the user to exploit the advantages of high resolution on low full-scale and low current consumption on high full-scale at the same time through SPI and I²C digital interfaces.

Table 3. Operating mode

AVdd	AVdd_OIS	Operating mode	I2C interface	SPI interface
OFF	OFF	Gyro off	Not available	Not available
ON	OFF	UI	Read/Write UI registers	Not available
OFF	ON	OIS	Not available	Read/Write OIS registers
ON	ON	OIS/UI	Read/Write UI registers	Read/Write OIS registers

When either AVdd or HAVdd are removed they must be connected to GND for proper working of the device.

4 User interface mode specifications

4.1 Mechanical characteristics

@ AVdd = 2.8 V, T = 25 °C unless otherwise noted^(a).

Table 4. Mechanical characteristics

Symbol	Parameter	Test condition	Min.	Typ. ⁽¹⁾	Max.	Unit
FS	Measurement range	User selectable		±250		dps
				±500		
				±2000		
So	Sensitivity	FS = 250 dps		8.75		mdps/digit
		FS = 500 dps		17.50		
		FS = 2000 dps		70		
SoDr	Sensitivity change vs. temperature	From -30 °C to +85 °C Delta from T = 25 °C		±2		%
DVoff	Digital zero-rate level	FS = 250 dps		±25		dps
		FS = 500 dps		±25		
		FS = 2000 dps		±25		
OffDr	Zero-rate level change vs. temperature	FS = 250 dps		±0.03		dps/°C
		FS = 2000 dps		±0.04		dps/°C
NL	Non linearity ⁽²⁾	Best fit straight line		0.2		% FS
Rn	Rate noise density			0.015		dps/ ($\sqrt{\text{Hz}}$)
BW	System bandwidth			140		Hz
Ton	Turn-on time	From power-down to normal mode		60		ms
ODR	Digital output data rate			95/190/ 380/760		Hz
Top	Operating temperature range		-30		+85	°C

1. Typical specifications are not guaranteed.

2. Guaranteed by design.

a. The product is factory calibrated at 3.3 V. The operational power supply range is specified in [Table 5](#).

4.2 Electrical characteristics

@ AVdd = 2.8 V, T = 25 °C unless otherwise noted^(b).

Table 5. Electrical characteristics

Symbol	Parameter	Test condition	Min.	Typ. ⁽¹⁾	Max.	Unit
AVdd	Supply voltage		2.42	2.8	3.6	V
Vdd_IO_UI	Supply voltage for UI digital pins	Internal voltage reference	1.62	1.8	1.98	V
VddI2Cbus	Supply voltage I ² C bus	Allowed supply voltage for UI I ² C bus	1.62	1.8	1.98	V
Idd	Supply current			6		mA
IddSL	Supply current in sleep mode ⁽²⁾	Selectable by digital interface		3.2		mA
IddPdn	Supply current in power-down mode	Selectable by digital interface		20		µA
VIH	Digital high level input voltage		0.7*Vdd_IO_UI	Vdd_IO_UI	Vdd_IO_UI + 0.3	V
VIL	Digital low level input voltage		-0.3	0	0.3*Vdd_IO_UI	V
VOH	Digital high level output voltage	INT/DRDY signals	0.65*Vdd_IO_UI	Vdd_IO_UI	Vdd_IO_UI + 0.3	V
VOL	Digital low level output voltage	INT/DRDY signals	-0.3	0	0.35*Vdd_IO_UI	V
Top	Operating temperature range		-30		+85	°C

1. Typical specifications are not guaranteed.

2. Sleep mode introduces a faster turn-on time related to power-down mode.

b. The product is factory calibrated at 3.3 V.

4.3 Temperature sensor characteristics

@ AVdd = 2.8 V, T = 25 °C unless otherwise noted^(c).

Table 6. Electrical characteristics

Symbol	Parameter	Test condition	Min.	Typ. ⁽¹⁾	Max.	Unit
TSDr	Temperature sensor output change vs. temperature	-		-1		°C/digit
TODR	Temperature refresh rate			1		Hz
Top	Operating temperature range		-30		+85	°C

1. Typical specifications are not guaranteed.

4.4 Absolute maximum ratings

Stresses above those listed as “absolute maximum ratings” may cause permanent damage to the device. This is a stress rating only and functional operation of the device under these conditions is not implied. Exposure to maximum rating conditions for extended periods may affect device reliability.

Table 7. Absolute maximum ratings⁽¹⁾

Symbol	Ratings	Maximum value	Unit
AVdd	Supply voltage	-0.3 to 4.8	V
HAVdd	Supply voltage	-0.3 to 4.8	V
Vdd_IO_SPI	Vdd IO SPI interface	-0.3 to HAVdd +0.1	V
Vin(UI)	Input voltage on: (SCL, SDA, INT, DRDY)	-0.3 to AVdd +0.1	V
Vin(OIS)	Input voltage on: (CS_OIS, SDI/SDO_OIS, SCL_OIS)	-0.3 to Vdd_IO_SPI +0.1	V
T _{STG}	Storage temperature range	-40 to +125	°C
Sg	Acceleration g for 0.1 ms	10,000	g
ESD	Electrostatic discharge protection	2 (HBM)	kV
		1.5 (CDM)	kV
		200 (MM)	V

1. Supply voltage on any pin should never exceed 4.8 V.

c. The product is factory calibrated at 3.3 V.



This is a mechanical shock sensitive device, improper handling can cause permanent damage to the part.



This is an ESD sensitive device, improper handling can cause permanent damage to the part.

5 Image stabilization (OIS mode) specifications

5.1 Mechanical characteristics

@ HAVdd = 3.3 V, T = 25 °C unless otherwise noted^(d).

Table 8. Mechanical characteristics

Symbol	Parameter	Test condition	Min.	Typ. ⁽¹⁾	Max.	Unit
FS	Measurement range		±65			dps
So	Sensitivity			±225		LSb/dps
SoDr	Sensitivity change vs. temperature	From -30 °C to +85 °C		±5		%
DVoff	Digital zero-rate level	High pass filter disabled		±75		dps
		High pass filter enabled		±20		
OffDr	Zero-rate level change vs. temperature	High pass filter disabled		±25		dps
		High pass filter enabled		±10		
NL	Non linearity ⁽²⁾	Best fit straight line		±1		% FS
Rn	Rate noise density ⁽²⁾			0.008		dps/ ($\sqrt{\text{Hz}}$)
BW	Internal bandwidth	LPF0 set to '1'		370		Hz
PhDI	Phase delay	At 20 Hz (370 Hz BW selected)		4.5		deg
ODR	Digital output data rate			9.5		kHz
Top	Operating temperature range		-30		+85	°C

1. Typical specifications are not guaranteed.
2. Guaranteed by design.

d. The product is factory calibrated at 3.3 V. The operational power supply range is specified in [Table 5](#).

5.2 Electrical characteristics

@ HAVdd = 3.3 V, T = 25 °C unless otherwise noted^(e).

Table 9. Electrical characteristics

Symbol	Parameter	Test condition	Min.	Typ. ⁽¹⁾	Max.	Unit
HAVdd	Supply voltage		3.0	3.3	3.6	V
Vdd_IO_SPI	I/O pins supply voltage ⁽²⁾		1.71		HAVdd+0.1	V
Idd	Supply current	OIS and UI modes active		10		mA
IddSL	Supply current in sleep mode ⁽³⁾	Selectable by digital interface		3.2		mA
IddPdn	Supply current in power-down mode	Selectable by digital interface		20		μA
VIH	Digital high level input voltage		0.8*Vdd_I/O_SPI			V
VIL	Digital low level input voltage				0.2*Vdd_I/O_SPI	V
Top	Operating temperature range		-30		+85	°C

1. Typical specifications are not guaranteed.
2. It is possible to remove HAVdd maintaining Vdd_IO_SPI without blocking the communication busses, in this condition the measurement chain is powered off.
3. Sleep mode introduces a faster turn-on time related to power-down mode.

5.3 Temperature sensor characteristics

@ HAVdd = 3.3 V, T = 25 °C unless otherwise noted^(f).

Table 10. Electrical characteristics

Symbol	Parameter	Test condition	Min.	Typ. ⁽¹⁾	Max.	Unit
TSDr	Temperature sensor output change vs. temperature	-		-1		°C/digit
TODR	Temperature refresh rate			1		Hz
Top	Operating temperature range		-30		+85	°C

1. Typical specifications are not guaranteed.

e. The product is factory calibrated at 3.3 V.

f. The product is factory calibrated at 3.3 V.

5.4 Absolute maximum ratings

Stresses above those listed as “absolute maximum ratings” may cause permanent damage to the device. This is a stress rating only and functional operation of the device under these conditions is not implied. Exposure to maximum rating conditions for extended periods may affect device reliability.

Table 11. Absolute maximum ratings⁽¹⁾

Symbol	Ratings	Maximum value	Unit
AVdd	Supply voltage	-0.3 to 4.8	V
HAVdd	Supply voltage	-0.3 to 4.8	V
Vdd_IO_SPI	Vdd IO SPI interface	-0.3 to HAVdd +0.1	V
Vin(UI)	Input voltage on: (SCL, SDA, INT, DRDY)	-0.3 to AVdd +0.1	V
Vin(OIS)	Input voltage on: (CS_OIS, SDI/SDO_OIS, SCL_OIS)	-0.3 to Vdd_IO_SPI +0.1	V
T _{STG}	Storage temperature range	-40 to +125	°C
Sg	Acceleration g for 0.1 ms	10,000	g
ESD	Electrostatic discharge protection	2 (HBM)	kV
		1.5 (CDM)	kV
		200 (MM)	V

1. Supply voltage on any pin should never exceed 4.8 V.



This is a mechanical shock sensitive device, improper handling can cause permanent damage to the part.



This is an ESD sensitive device, improper handling can cause permanent damage to the part.

6 Application hints

Figure 3. L3G4IS electrical connections and external component values

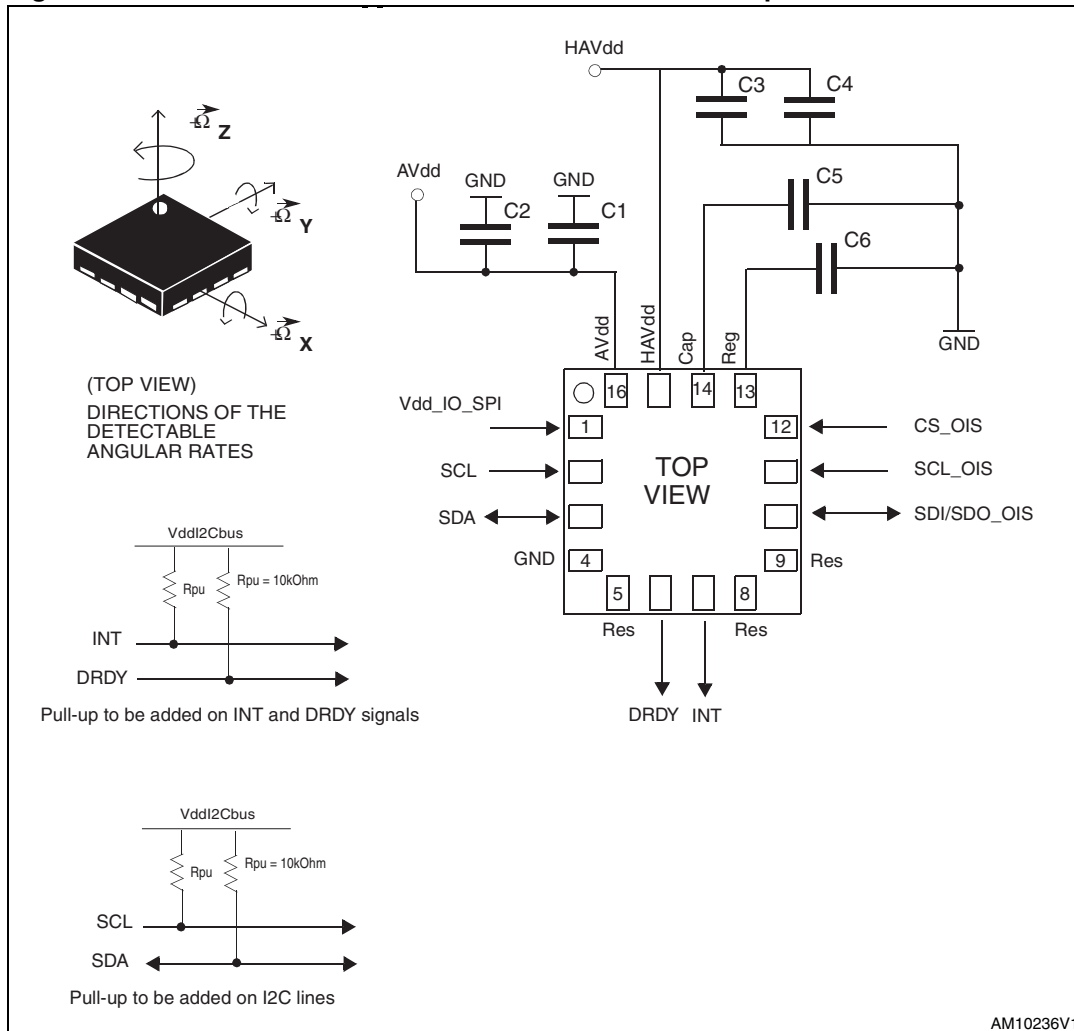

Table 12. External components

Type description	Value	Purpose
C1 = C3	1 μ F	Decoupling
C2 = C4	100 pF	Decoupling
C5 ⁽¹⁾	10 nF (25 V class)	Charge pump
C6	220 nF (5 V class)	Internal regulator
Rpu	10 k Ω	

1. This value must guarantee a minimum of 1 nF value under 11 V bias condition.

Power supply decoupling capacitors (100 pF + 1 μ F) should be placed as near as possible to the device (common design practice). Pull-up resistors must be added to I²C SDA and SCL lines and to INT and DRDY lines.

6.1 Power supply configurations

The L3G4IS can be powered according to several different configurations, as reported in [Section 3](#). Depending on the particular power supply provided, either the user interface or image stabilization modes are activated. The presence of a certain power supply determines also which digital interface is available. In [Figure 4](#) three possible power supply configurations are reported to further explain the high level of flexibility allowed by the component. It should be noted that when AVdd and HAVdd are removed they must be connected to GND for proper working of the device.

6.1.1 Configuration 1

Figure 4. L3G4IS power supply configuration 1

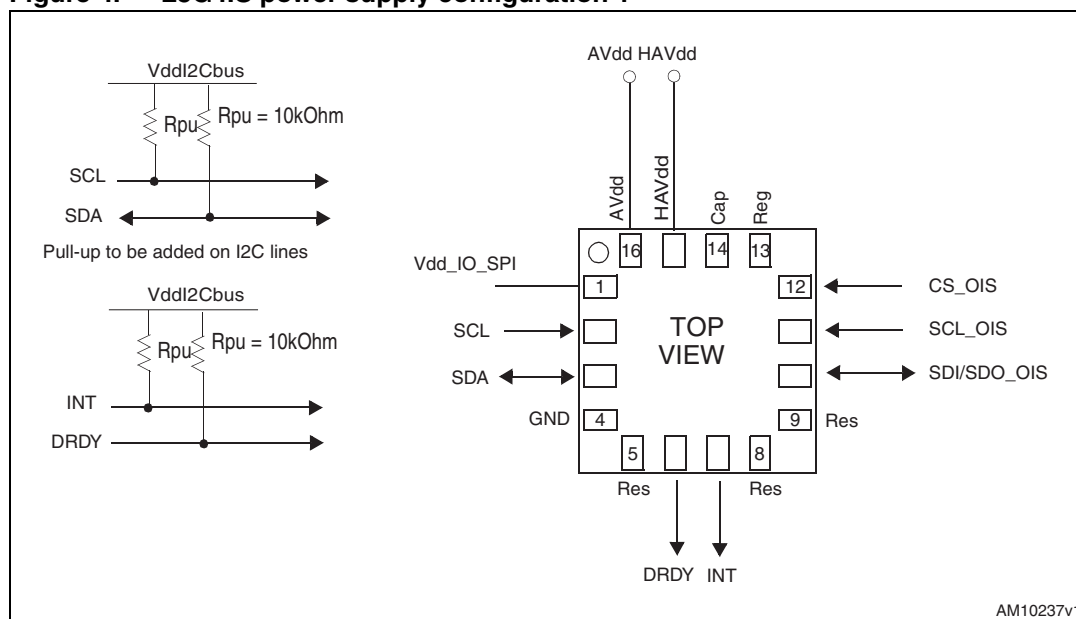

where:

- AVdd is ON
- HAVdd is ON
- UI and OIS modes enabled
- I²C (SCL/SDA) is supplied by AVdd
- DRDY/INT are supplied by AVdd
- Vdd_IO_SPI can be connected to any voltage in the range of 1.71 V to HAVdd.

Note: For complete external component placement please refer to [Figure 3: L3G4IS electrical connections and external component values](#).

6.1.2 Configuration 2

Figure 5. L3G4IS power supply configuration 2

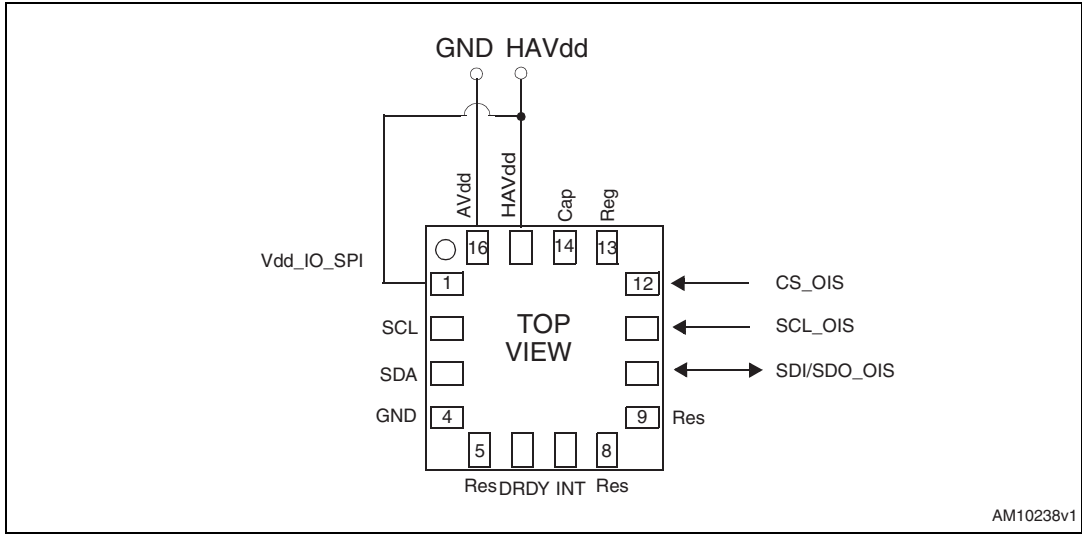

where:

- AVdd is OFF
- HAVdd is ON
- OIS mode enabled
- I²C (SCL/SDA) is not available
- Vdd_IO_SPI has been shorted to HAVdd: SPI is now powered by HAVdd.

Note: For complete external component placement please refer to [Figure 3: L3G4IS electrical connections and external component values](#).

6.1.3 Configuration 3

Figure 6. L3G4IS power supply configuration 3

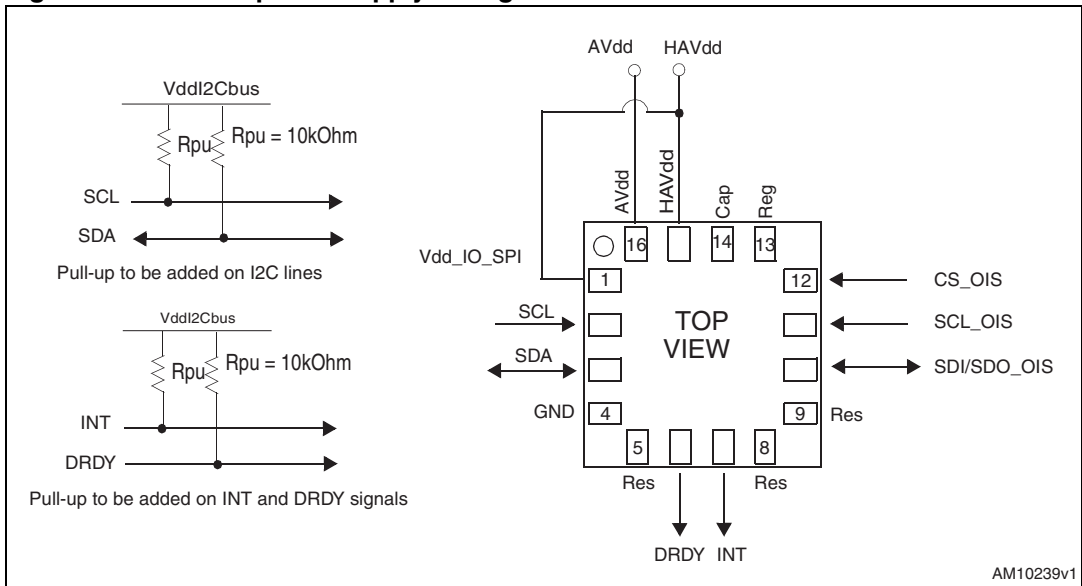

where:

- AVdd is ON
- HAVdd is ON
- OIS mode enabled
- UI mode enabled
- I²C (SCL/SDA) is available (internally powered at 1.8 ± 10%)
- DRDY/INT are available
- Vdd_IO_SPI has been shorted to HAVdd: SPI is now powered by HAVdd.

Note: For complete external component placement please refer to [Figure 3: L3G4IS electrical connections and external component values](#).

6.1.4 Configuration 4 (case use)

Figure 7. L3G4IS power supply configuration 4 (case use)

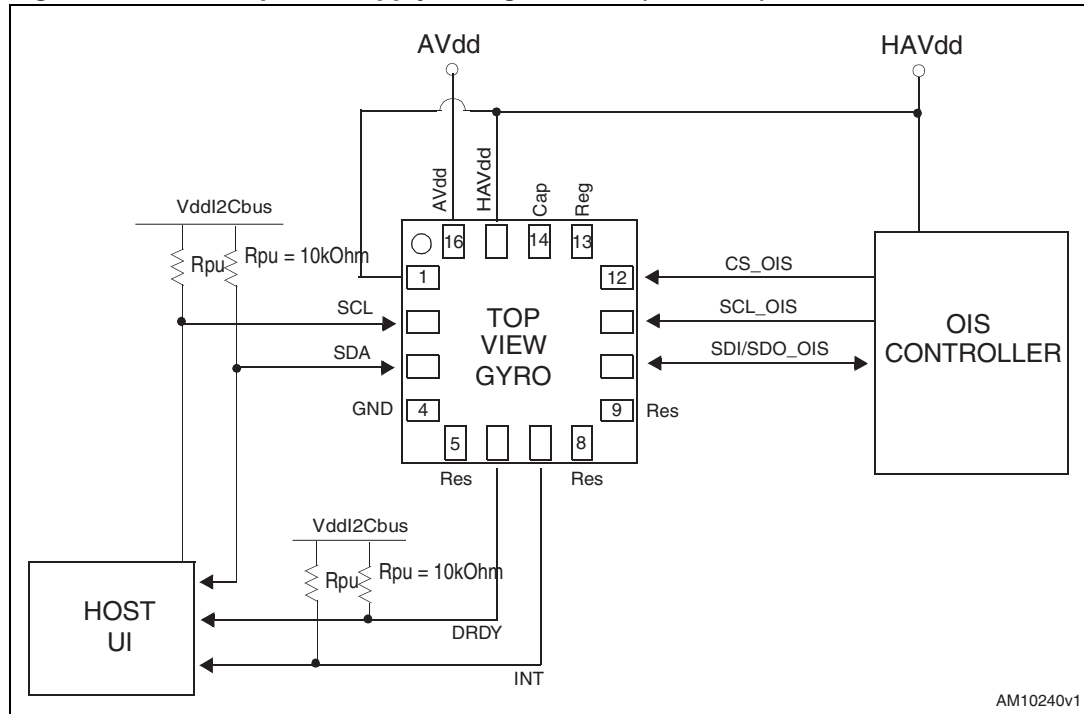

Note: For complete external component placement please refer to [Figure 3: L3G4IS electrical connections and external component values](#).

7 Soldering information

The LGA package is compliant with the ECOPACK[®], RoHS and “Green” standard. It is qualified for soldering heat resistance according to JEDEC J-STD-020.

Leave “Pin 1 Indicator” unconnected during soldering.

Land pattern and soldering recommendations are available at www.st.com/mems.

8 Package information

In order to meet environmental requirements, ST offers these devices in different grades of ECOPACK® packages, depending on their level of environmental compliance. ECOPACK specifications, grade definitions and product status are available at: www.st.com. ECOPACK is an ST trademark.

Figure 8. LGA-16: mechanical data and package dimensions

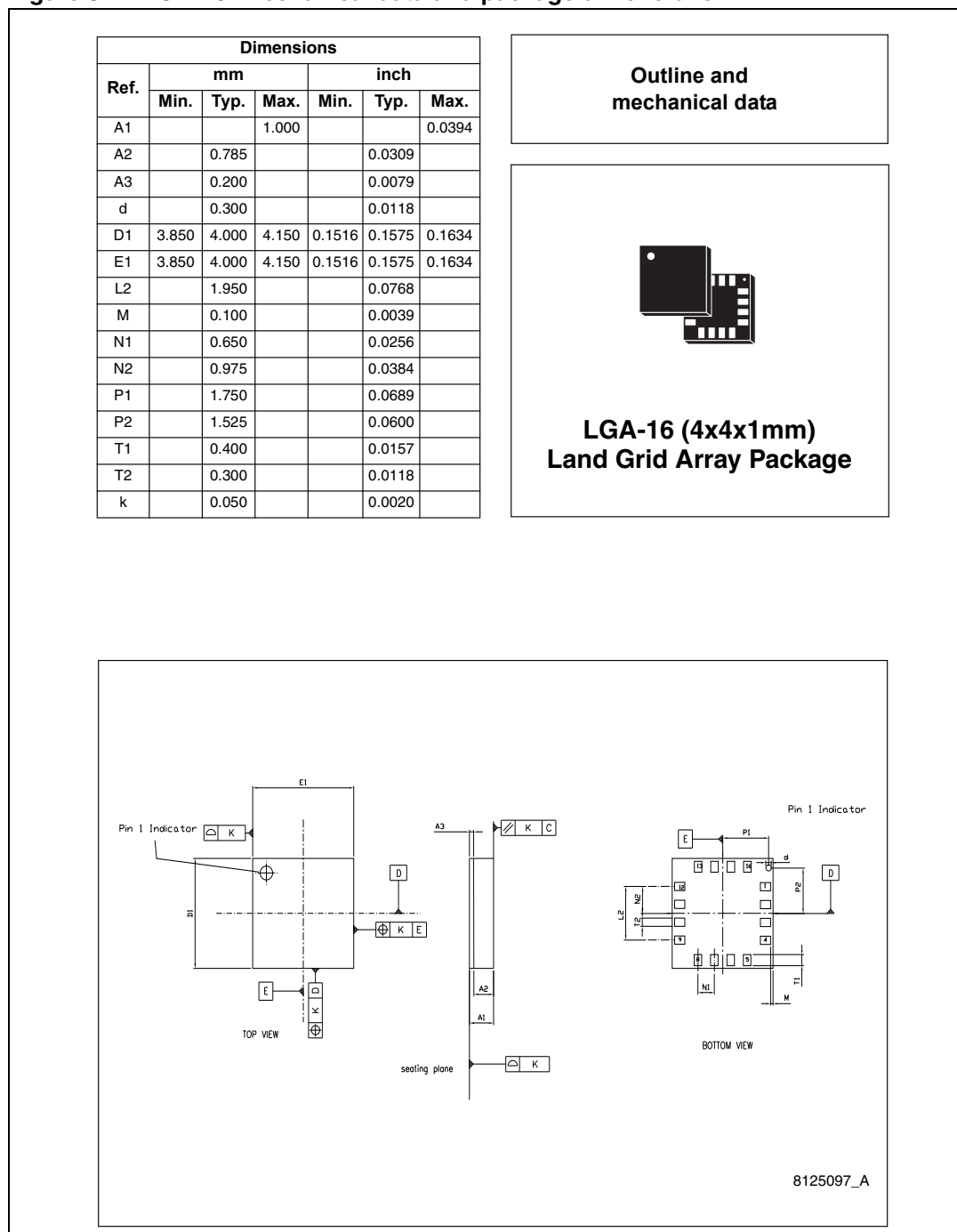

9 Revision history

Table 13. Document revision history

Date	Revision	Changes
22-Dec-2011	1	Initial release.

Please Read Carefully:

Information in this document is provided solely in connection with ST products. STMicroelectronics NV and its subsidiaries ("ST") reserve the right to make changes, corrections, modifications or improvements, to this document, and the products and services described herein at any time, without notice.

All ST products are sold pursuant to ST's terms and conditions of sale.

Purchasers are solely responsible for the choice, selection and use of the ST products and services described herein, and ST assumes no liability whatsoever relating to the choice, selection or use of the ST products and services described herein.

No license, express or implied, by estoppel or otherwise, to any intellectual property rights is granted under this document. If any part of this document refers to any third party products or services it shall not be deemed a license grant by ST for the use of such third party products or services, or any intellectual property contained therein or considered as a warranty covering the use in any manner whatsoever of such third party products or services or any intellectual property contained therein.

UNLESS OTHERWISE SET FORTH IN ST'S TERMS AND CONDITIONS OF SALE ST DISCLAIMS ANY EXPRESS OR IMPLIED WARRANTY WITH RESPECT TO THE USE AND/OR SALE OF ST PRODUCTS INCLUDING WITHOUT LIMITATION IMPLIED WARRANTIES OF MERCHANTABILITY, FITNESS FOR A PARTICULAR PURPOSE (AND THEIR EQUIVALENTS UNDER THE LAWS OF ANY JURISDICTION), OR INFRINGEMENT OF ANY PATENT, COPYRIGHT OR OTHER INTELLECTUAL PROPERTY RIGHT.

UNLESS EXPRESSLY APPROVED IN WRITING BY TWO AUTHORIZED ST REPRESENTATIVES, ST PRODUCTS ARE NOT RECOMMENDED, AUTHORIZED OR WARRANTED FOR USE IN MILITARY, AIR CRAFT, SPACE, LIFE SAVING, OR LIFE SUSTAINING APPLICATIONS, NOR IN PRODUCTS OR SYSTEMS WHERE FAILURE OR MALFUNCTION MAY RESULT IN PERSONAL INJURY, DEATH, OR SEVERE PROPERTY OR ENVIRONMENTAL DAMAGE. ST PRODUCTS WHICH ARE NOT SPECIFIED AS "AUTOMOTIVE GRADE" MAY ONLY BE USED IN AUTOMOTIVE APPLICATIONS AT USER'S OWN RISK.

Resale of ST products with provisions different from the statements and/or technical features set forth in this document shall immediately void any warranty granted by ST for the ST product or service described herein and shall not create or extend in any manner whatsoever, any liability of ST.

ST and the ST logo are trademarks or registered trademarks of ST in various countries.

Information in this document supersedes and replaces all information previously supplied.

The ST logo is a registered trademark of STMicroelectronics. All other names are the property of their respective owners.

© 2011 STMicroelectronics - All rights reserved

STMicroelectronics group of companies

Australia - Belgium - Brazil - Canada - China - Czech Republic - Finland - France - Germany - Hong Kong - India - Israel - Italy - Japan - Malaysia - Malta - Morocco - Philippines - Singapore - Spain - Sweden - Switzerland - United Kingdom - United States of America

www.st.com