



KSZ8081MLX

10BASE-T/100BASE-TX Physical Layer Transceiver

Features

- Single-Chip 10BASE-T/100BASE-TX IEEE 802.3 Compliant Ethernet Transceiver
- MII Interface Support
- Back-to-Back Mode Support for a 100 Mbps Copper Repeater
- MDC/MDIO Management Interface for PHY Register Configuration
- Programmable Interrupt Output
- LED Outputs for Link and Activity Status Indication
- On-Chip Termination Resistors for the Differential Pairs
- Baseline Wander Correction
- HP Auto MDI/MDI-X to Reliably Detect and Correct Straight-Through and Crossover Cable Connections with Disable and Enable Option
- Auto-Negotiation to Automatically Select the Highest Link-Up Speed (10/100 Mbps) and Duplex (Half/Full)
- Power-Down and Power-Saving Modes
- LinkMD[®] TDR-Based Cable Diagnostics to Identify Faulty Copper Cabling
- Parametric NAND Tree Support for Fault Detection Between Chip I/Os and the Board
- HBM ESD Rating (6 kV)
- Loopback Modes for Diagnostics
- Single 3.3V Power Supply with V_{DD} I/O Options for 1.8V, 2.5V, or 3.3V
- Built-In 1.2V Regulator for Core
- Available in 48-pin 7 mm x 7 mm LQFP Package

Target Applications

- Game Consoles
- IP Phones
- IP Set-Top Boxes
- IP TVs
- LOM
- Printers

TO OUR VALUED CUSTOMERS

It is our intention to provide our valued customers with the best documentation possible to ensure successful use of your Microchip products. To this end, we will continue to improve our publications to better suit your needs. Our publications will be refined and enhanced as new volumes and updates are introduced.

If you have any questions or comments regarding this publication, please contact the Marketing Communications Department via E-mail at docerrors@microchip.com. We welcome your feedback.

Most Current Data Sheet

To obtain the most up-to-date version of this data sheet, please register at our Worldwide Web site at:

<http://www.microchip.com>

You can determine the version of a data sheet by examining its literature number found on the bottom outside corner of any page. The last character of the literature number is the version number, (e.g., DS30000000A is version A of document DS30000000).

Errata

An errata sheet, describing minor operational differences from the data sheet and recommended workarounds, may exist for current devices. As device/documentation issues become known to us, we will publish an errata sheet. The errata will specify the revision of silicon and revision of document to which it applies.

To determine if an errata sheet exists for a particular device, please check with one of the following:

- Microchip's Worldwide Web site; <http://www.microchip.com>
- Your local Microchip sales office (see last page)

When contacting a sales office, please specify which device, revision of silicon and data sheet (include -literature number) you are using.

Customer Notification System

Register on our web site at www.microchip.com to receive the most current information on all of our products.

Table of Contents

1.0 Introduction	4
2.0 Pin Description and Configuration	5
3.0 Functional Description	11
4.0 Register Descriptions	26
5.0 Operational Characteristics	35
6.0 Electrical Characteristics	36
7.0 Timing Diagrams	38
8.0 Reset Circuit	46
9.0 Reference Circuits — LED Strap-In Pins	47
10.0 Reference Clock - Connection and Selection	48
11.0 Magnetic - Connection and Selection	49
12.0 Package Outline	51
Appendix A: Data Sheet Revision History	52
The Microchip Web Site	53
Customer Change Notification Service	53
Customer Support	53
Product Identification System	54

KSZ8081MLX

1.0 INTRODUCTION

1.1 General Description

The KSZ8081MLX is a single-supply 10BASE-T/100BASE-TX Ethernet physical-layer transceiver for transmission and reception of data over standard CAT-5 unshielded twisted pair (UTP) cable.

The KSZ8081MLX is a highly-integrated, compact solution. It reduces board cost and simplifies board layout by using on-chip termination resistors for the differential pairs, by integrating a low-noise regulator to supply the 1.2V core, and by offering 1.8/2.5/3.3V digital I/O interface support.

The KSZ8081MLX offers the Media Independent Interface (MII) for direct connection with MII-compliant Ethernet MAC processors and switches.

The KSZ8081MLX provides diagnostic features to facilitate system bring-up and debugging in production testing and in product deployment. Parametric NAND tree support enables fault detection between KSZ8081MLX I/Os and the board. LinkMD[®] TDR-based cable diagnostics identify faulty copper cabling.

The KSZ8081MLX is available in the 48-pin, lead-free LQFP package.

FIGURE 1-1: SYSTEM BLOCK DIAGRAM

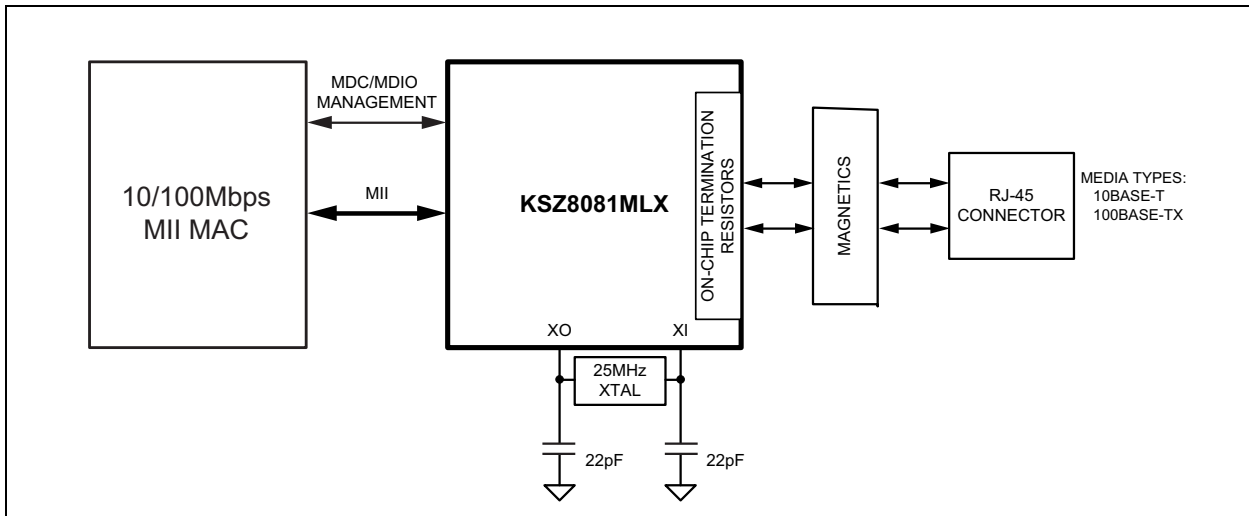

2.0 PIN DESCRIPTION AND CONFIGURATION

FIGURE 2-1: 48-PIN 7 MM X 7 MM LQFP ASSIGNMENT (TOP VIEW)

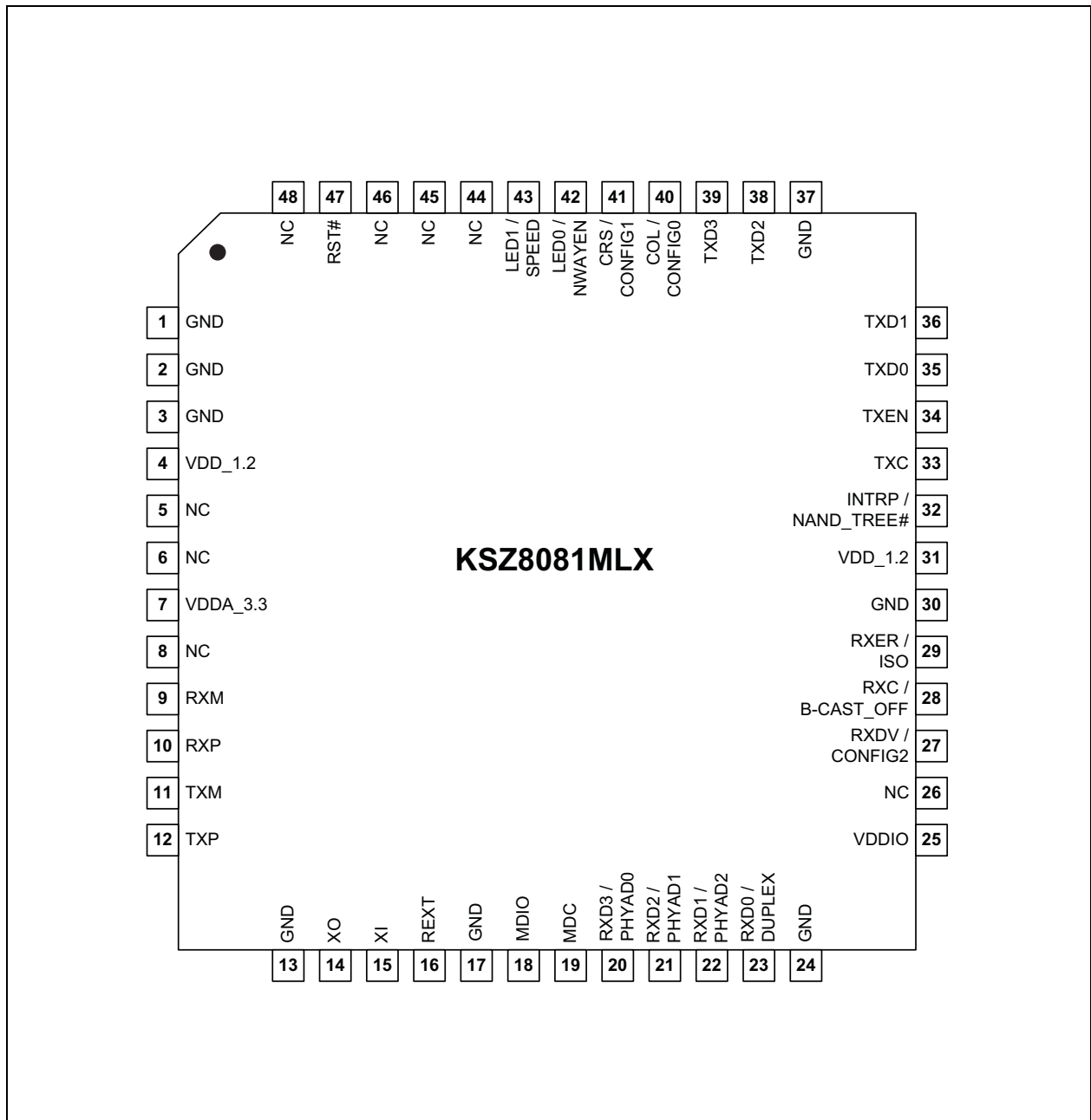

KSZ8081MLX

TABLE 2-1: SIGNALS - KSZ8081MLX

Pin Number	Pin Name	Type Note 2-1	Description
1	GND	GND	Ground.
2	GND	GND	Ground.
3	GND	GND	Ground.
4	VDD_!2	P	1.2V Core V _{DD} (power supplied by KSZ8081MLX). Decouple with 2.2 μ F and 0.1 μ F capacitors to ground, and join with Pin 31 by power trace or plane.
5	NC	—	No Connect. This pin is not bonded and can be left floating.
6	NC	—	No Connect. This pin is not bonded and can be left floating.
7	VDDA_3.3	P	3.3V Analog V _{DD} .
8	NC	—	No Connect. This pin is not bonded and can be left floating.
9	RXM	I/O	Physical Receive or Transmit Signal (– differential).
10	RXP	I/O	Physical Receive or Transmit Signal (+ differential).
11	TXM	I/O	Physical Transmit or Receive Signal (– differential).
12	TXP	I/O	Physical Transmit or Receive Signal (+ differential).
13	GND	GND	Ground.
14	XO	O	Crystal Feedback for 25 MHz Crystal. This pin is a no connect if an oscillator or external clock source is used.
15	XI	I	Crystal/Oscillator/External Clock Input (25 MHz \pm 50 ppm).
16	REXT	I	Set PHY Transmit Output Current. Connect a 6.49 k Ω resistor to ground on this pin.
17	GND	GND	Ground.
18	MDIO	Ipu/ Opu	Management Interface (MII) Data I/O. This pin has a weak pull-up, is open-drain, and requires an external 1.0 k Ω pull-up resistor.
19	MDC	Ipu	Management Interface (MII) Clock Input. This clock pin is synchronous to the MDIO data pin.
20	RXD3/ PHYAD0	Ipu/O	MII Mode: MII Receive Data Output[3] (Note 2-2) Config. Mode: The pull-up/pull-down value is latched as PHYADDR[0] at the de-assertion of reset. See the Strap-In Options - KSZ8081MLX section for details.
21	RXD2/ PHYAD1	Ipd/O	MII Mode: MII Receive Data Output[2] (Note 2-2) Config. Mode: The pull-up/pull-down value is latched as PHYADDR[1] at the de-assertion of reset. See the Strap-In Options - KSZ8081MLX section for details.
22	RXD1/ PHYAD2	Ipd/O	MII Mode: MII Receive Data Output[1] (Note 2-2) Config. Mode: The pull-up/pull-down value is latched as PHYADDR[2] at the de-assertion of reset. See the Strap-In Options - KSZ8081MLX section for details.

TABLE 2-1: SIGNALS - KSZ8081MLX (CONTINUED)

Pin Number	Pin Name	Type Note 2-1	Description
23	RXD0/ DUPLEX	Ipu/O	MII Mode: MII Receive Data Output[0] (Note 2-2) Config. Mode: The pull-up/pull-down value is latched as DUPLEX at the de-assertion of reset. See the Strap-In Options - KSZ8081MLX section for details.
24	GND	GND	Ground.
25	VDDIO	P	3.3V, 2.5V, or 1.8V Digital V _{DD} .
26	NC	—	No Connect. This pin is not bonded and can be left floating.
27	RXDV/ CONFIG2	Ipd/O	MII Mode: MII Receive Data Valid Output. Config. Mode: The pull-up/pull-down value is latched as CONFIG2 at the de-assertion of reset. See the Strap-In Options - KSZ8081MLX section for details.
28	RXC/ B-CAST_OFF	Ipd/O	MII Mode: MII Receive Clock Output. Config. Mode: The pull-up/pull-down value is latched as B-CAST_OFF at the de-assertion of reset. See the Strap-In Options - KSZ8081MLX section for details.
29	RXER/ ISO	Ipd/O	MII Mode: MII Receive Error output Config. Mode: The pull-up/pull-down value is latched as ISOLATE at the de-assertion of reset. See the Strap-In Options - KSZ8081MLX section for details.
30	GND	GND	Ground.
31	VDD_1.2	P	1.2V Core V _{DD} (power supplied by KSZ8081MLX). Decouple with 0.1 µF capacitor to ground, and join with Pin 4 by power trace or plane.
32	INTRP/ NAND_Tree#	Ipu/ Opu	Interrupt Output: Programmable interrupt output. This pin has a weak pull-up, is open drain, and requires an external 1.0 kΩ pull-up resistor. Config. Mode: The pull-up/pull-down value is latched as NAND Tree# at the de-assertion of reset. See the Strap-In Options - KSZ8081MLX section for details.
33	TXC	Ipd/O	MII Mode: MII Transmit Clock Output. At the de-assertion of reset, this pin needs to latch in a pull-down value for normal operation. If MAC side pulls this pin high, see Register 16h, Bit [15] for solution. It is better having an external pull-down resistor to avoid MAC side pulls this pin high.
34	TXEN	I	MII Mode: MII Transmit Enable input.
35	TXD0	I	MII Mode: MII Transmit Data Input[0] (Note 2-3)
36	TXD1	I	MII Mode: MII Transmit Data Input[1] (Note 2-3)
37	GND	GND	Ground.
38	TXD2	I	MII Mode: MII Transmit Data Input[2] (Note 2-3)
39	TXD3	I	MII Mode: MII Transmit Data Input[3] (Note 2-3)

KSZ8081MLX

TABLE 2-1: SIGNALS - KSZ8081MLX (CONTINUED)

Pin Number	Pin Name	Type Note 2-1	Description			
40	COL/ CONFIG0	lpd/O	MII Mode: MII Collision Detect output Config. Mode: The pull-up/pull-down value is latched as CONFIG0 at the de-assertion of reset. See the Strap-In Options - KSZ8081MLX section for details.			
41	CRS/ CONFIG1	lpd/O	MII Mode: MII Carrier Sense Output Config. Mode: The pull-up/pull-down value is latched as CONFIG1 at the de-assertion of reset. See the Strap-In Options - KSZ8081MLX section for details.			
42	LED0/ NWAYEN	lpu/O	LED Output: Programmable LED0 Output Config. Mode: Latched as auto-negotiation enable (Register 0h, Bit [12]) at the de-assertion of reset. See the Strap-In Options section for details. The LED0 pin is programmable using Register 1Fh Bits [5:4], and is defined as follows:			
			LED Mode = [00]			
			Link/Activity	Pin State	LED Definition	
			No Link	High	OFF	
			Link	Low	ON	
			Activity	Toggle	Blinking	
			LED Mode = [01]			
			Link	Pin State	LED Definition	
			No Link	High	OFF	
			Link	Low	ON	
			LED Mode = [10], [11] Reserved			
			43	LED1/ SPEED	lpu/O	LED Output: Programmable LED1 output Config. Mode: Latched as Speed (Register 0h, Bit [13]) at the de-assertion of reset. See the Strap-In Options section for details. The LED1 pin is programmable using Register 1Fh Bits [5:4], and is defined as follows:
						LED Mode = [00]
Speed	Pin State	LED Definition				
10BASE-T	High	OFF				
100BASE-TX	Low	ON				
LED Mode = [01]						
Activity	Pin State	LED Definition				
No Activity	High	OFF				
Activity	Toggle	Blinking				
LED Mode = [10], [11] Reserved						

TABLE 2-1: SIGNALS - KSZ8081MLX (CONTINUED)

Pin Number	Pin Name	Type Note 2-1	Description
44	TEST/NC	lpd	No Connect for normal operation, an external pull-up resistor for NAND tree testing.
45	NC	—	No Connect. This pin is not bonded and can be left floating.
46	NC	—	No Connect. This pin is not bonded and can be left floating.
47	RST#	lpu	Chip Reset (active low).
48	NC	—	No Connect. This pin is not bonded and can be left floating.

Note 2-1 P = power supply
 GND = ground
 I = input
 O = output
 I/O = bi-directional
 lpu = Input with internal pull-up (see [Electrical Characteristics](#) for value).
 lpu/O = Input with internal pull-up (see [Electrical Characteristics](#) for value) during power-up/reset; output pin otherwise.
 lpd/O = Input with internal pull-down (see [Electrical Characteristics](#) for value) during power-up/reset; output pin otherwise.
 lpu/Opu = Input with internal pull-up (see [Electrical Characteristics](#) for value) and output with internal pull-up (see [Electrical Characteristics](#) for value).

Note 2-2 MII RX Mode: The RXD[3:0] bits are synchronous with RXC. When RXDV is asserted, RXD[3:0] presents valid data to the MAC.

Note 2-3 MII TX Mode: The TXD[3:0] bits are synchronous with TXC. When TXEN is asserted, TXD[3:0] presents valid data from the MAC.

2.1 Strap-In Options

The PHYAD[1:0] strap-in pin is latched at the de-assertion of reset. In some systems, the RMII MAC receive input pins may drive high/low during power-up or reset, and consequently cause the PHYAD[1:0] strap-in pin, a shared pin with the RMII CRS_DV signal, to be latched to the unintended high/low state. In this case an external pull-up (4.7 kΩ) or pull-down (1.0 kΩ) should be added on the PHYAD[1:0] strap-in pin to ensure that the intended value is strapped-in correctly.

TABLE 2-2: STRAP-IN OPTIONS - KSZ8081MLX

Pin Number	Pin Name	Type Note 2-4	Description	
22	PHYAD2	lpd/O	The PHY address is latched at de-assertion of reset and is configurable to any value from 0 to 7. The default PHY address is 00001. PHY address 00000 is enabled only if the B-CAST_OFF strap-in pin is pulled high. PHY address Bits [4:3] are set to 00 by default.	
21	PHYAD1			
20	PHYAD0			
27	CONFIG2	lpd/O	The CONFIG[2:0] strap-in pins are latched at the de-assertion of reset.	
41	CONFIG1		CONFIG[2:0]	Mode
			000	MI1 (default)
40	CONFIG0		110	MI1 back-to-back
		001 – 101, 111	Reserved, not used	

KSZ8081MLX

TABLE 2-2: STRAP-IN OPTIONS - KSZ8081MLX (CONTINUED)

Pin Number	Pin Name	Type Note 2-4	Description
29	ISO	lpd/O	Isolate Mode: Pull-up = Enable Pull-down (default) = Disable At the de-assertion of reset, this pin value is latched into Register 0h, Bit [10].
43	SPEED	lpu/O	Speed Mode: Pull-up (default) = 100 Mbps Pull-down = 10 Mbps At the de-assertion of reset, this pin value is latched into Register 0h, Bit [13] as the speed select, and also is latched into Register 4h (auto-negotiation advertisement) as the speed capability support.
23	DUPLEX	lpu/O	Duplex Mode: Pull-up (default) = Half-duplex Pull-down = Full-duplex At the de-assertion of reset, this pin value is latched into Register 0h, Bit [8].
42	NWAYEN	lpu/O	Nway Auto-Negotiation Enable: Pull-up (default) = Enable auto-negotiation Pull-down = Disable auto-negotiation At the de-assertion of reset, this pin value is latched into Register 0h, Bit [12].
28	B-CAST_OFF	lpd/O	Broadcast Off – for PHY Address 0: Pull-up = PHY Address 0 is set as an unique PHY address Pull-down (default) = PHY Address 0 is set as a broadcast PHY address At the de-assertion of reset, this pin value is latched by the chip.
32	NAND_Tree#	lpu/Opu	NAND Tree Mode: Pull-up (default) = Disable Pull-down = Enable At the de-assertion of reset, this pin value is latched by the chip.

Note 2-4 lpu/O = Input with internal pull-up (see [Electrical Characteristics](#) for value) during power-up/reset; output pin otherwise.
 lpd/O = Input with internal pull-down (see [Electrical Characteristics](#) for value) during power-up/reset; output pin otherwise.
 lpu/Opu = Input with internal pull-up (see [Electrical Characteristics](#) for value) and output with internal pull-up (see [Electrical Characteristics](#) for value).

3.0 FUNCTIONAL DESCRIPTION

The KSZ8081MLX is an integrated single 3.3V supply Fast Ethernet transceiver. It is fully compliant with the IEEE 802.3 Specification, and reduces board cost and simplifies board layout by using on-chip termination resistors for the two differential pairs and by integrating the regulator to supply the 1.2V core.

On the copper media side, the KSZ8081MLX supports 10BASE-T and 100BASE-TX for transmission and reception of data over a standard CAT-5 unshielded twisted pair (UTP) cable, and HP Auto MDI/MDI-X for reliable detection of and correction for straight-through and crossover cables.

On the MAC processor side, the KSZ8081MLX offers the Media Independent Interface (MII) for direct connection with MII compliant Ethernet MAC processors and switches.

The MII management bus option gives the MAC processor complete access to the KSZ8081MLX control and status registers. Additionally, an interrupt pin eliminates the need for the processor to poll for PHY status change.

3.1 10BASE-T/100BASE-TX Transceiver

3.1.1 100BASE-TX TRANSMIT

The 100BASE-TX transmit function performs parallel-to-serial conversion, 4B/5B encoding, scrambling, NRZ-to-NRZI conversion, and MLT3 encoding and transmission.

The circuitry starts with a parallel-to-serial conversion, which converts the MII data from the MAC into a 125 MHz serial bit stream. The data and control stream is then converted into 4B/5B coding and followed by a scrambler. The serialized data is further converted from NRZ-to-NRZI format, and then transmitted in MLT3 current output. The output current is set by an external 6.49 k Ω 1% resistor for the 1:1 transformer ratio.

The output signal has a typical rise/fall time of 4 ns and complies with the ANSI TP-PMD standard regarding amplitude balance, overshoot, and timing jitter. The wave-shaped 10BASE-T output is also incorporated into the 100BASE-TX transmitter.

3.1.2 100BASE-TX RECEIVE

The 100BASE-TX receiver function performs adaptive equalization, DC restoration, MLT3-to-NRZI conversion, data and clock recovery, NRZI-to-NRZ conversion, de-scrambling, 4B/5B decoding, and serial-to-parallel conversion.

The receiving side starts with the equalization filter to compensate for inter-symbol interference (ISI) over the twisted pair cable. Because the amplitude loss and phase distortion is a function of the cable length, the equalizer must adjust its characteristics to optimize performance. In this design, the variable equalizer makes an initial estimation based on comparisons of incoming signal strength against some known cable characteristics, then tunes itself for optimization. This is an ongoing process and self-adjusts against environmental changes such as temperature variations.

Next, the equalized signal goes through a DC-restoration and data-conversion block. The DC-restoration circuit compensates for the effect of baseline wander and improves the dynamic range. The differential data-conversion circuit converts MLT3 format back to NRZI. The slicing threshold is also adaptive.

The clock-recovery circuit extracts the 125 MHz clock from the edges of the NRZI signal. This recovered clock is then used to convert the NRZI signal into NRZ format. This signal is sent through the de-scrambler, then the 4B/5B decoder. Finally, the NRZ serial data is converted to MII format and provided as the input data to the MAC.

3.1.3 SCRAMBLER/DE-SCRAMBLER (100BASE-TX ONLY)

The scrambler spreads the power spectrum of the transmitted signal to reduce electromagnetic interference (EMI) and baseline wander. The de-scrambler recovers the scrambled signal.

3.1.4 10BASE-T TRANSMIT

The 10BASE-T drivers are incorporated with the 100BASE-TX drivers to allow for transmission using the same magnetic. The drivers perform internal wave-shaping and pre-emphasis, and output 10BASE-T signals with typical amplitude of 2.5V peak. The 10BASE-T signals have harmonic contents that are at least 27 dB below the fundamental frequency when driven by an all-ones Manchester-encoded signal.

3.1.5 10BASE-T RECEIVE

On the receive side, input buffer and level detecting squelch circuits are used. A differential input receiver circuit and a phase-locked loop (PLL) performs the decoding function. The Manchester-encoded data stream is separated into clock signal and NRZ data. A squelch circuit rejects signals with levels less than 400 mV, or with short pulse widths, to prevent

KSZ8081MLX

noise at the RXP and RXM inputs from falsely triggering the decoder. When the input exceeds the squelch limit, the PLL locks onto the incoming signal and the KSZ8081MLX decodes a data frame. The receive clock is kept active during idle periods between data receptions.

3.1.6 SQE AND JABBER FUNCTION (10BASE-T ONLY)

In 10BASE-T operation, a short pulse is put out on the COL pin after each frame is transmitted. This SQE test is needed to test the 10BASE-T transmit/receive path. If transmit enable (TXEN) is high for more than 20 ms (jabbering), the 10BASE-T transmitter is disabled and COL is asserted high. If TXEN is then driven low for more than 250 ms, the 10BASE-T transmitter is re-enabled and COL is de-asserted (returns to low).

3.1.7 PLL CLOCK SYNTHESIZER

The KSZ8081MLX generates all internal clocks and all external clocks for system timing from an external 25 MHz crystal, oscillator, or reference clock.

3.1.8 AUTO-NEGOTIATION

The KSZ8081MLX conforms to the auto-negotiation protocol, defined in Clause 28 of the IEEE 802.3 Specification.

Auto-negotiation allows unshielded twisted pair (UTP) link partners to select the highest common mode of operation.

During auto-negotiation, link partners advertise capabilities across the UTP link to each other and then compare their own capabilities with those they received from their link partners. The highest speed and duplex setting that is common to the two link partners is selected as the mode of operation.

The following list shows the speed and duplex operation mode from highest to lowest priority.

- Priority 1: 100BASE-TX, full-duplex
- Priority 2: 100BASE-TX, half-duplex
- Priority 3: 10BASE-T, full-duplex
- Priority 4: 10BASE-T, half-duplex

If auto-negotiation is not supported or the KSZ8081MLX link partner is forced to bypass auto-negotiation, then the KSZ8081MLX sets its operating mode by observing the signal at its receiver. This is known as parallel detection, and allows the KSZ8081MLX to establish a link by listening for a fixed signal protocol in the absence of the auto-negotiation advertisement protocol.

Auto-negotiation is enabled by either hardware pin strapping (NWAYEN, Pin 42) or software (Register 0h, Bit [12]).

By default, auto-negotiation is enabled after power-up or hardware reset. After that, auto-negotiation can be enabled or disabled by Register 0h, Bit [12]. If auto-negotiation is disabled, the speed is set by Register 0h, Bit [13], and the duplex is set by Register 0h, Bit [8].

The auto-negotiation link-up process is shown in [Figure 3-1](#).

FIGURE 3-1: AUTO-NEGOTIATION FLOW CHART

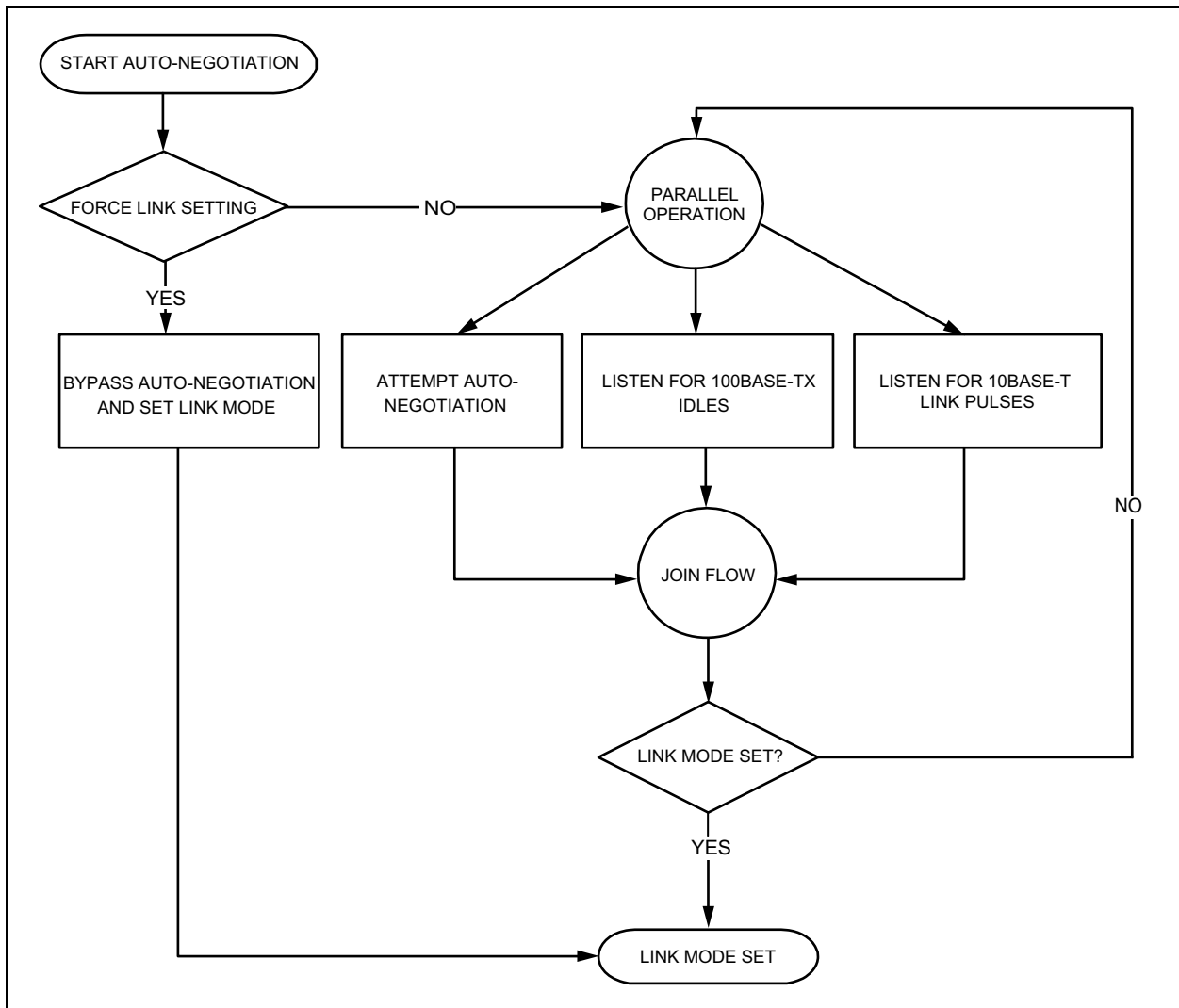

3.2 MII Interface

The Media Independent Interface (MII) is compliant with the IEEE 802.3 Specification. It provides a common interface between MII PHYs and MACs, and has the following key characteristics:

- Pin count is 15 pins (6 pins for data transmission, 7 pins for data reception, and 2 pins for carrier and collision indication).
- 10 Mbps and 100 Mbps data rates are supported at both half- and full-duplex.
- Data transmission and reception are independent and belong to separate signal groups.
- Transmit data and receive data are each 4 bits wide, a nibble.

By default, the KSZ8081MLX is configured to MII mode after it is powered up or hardware reset with the following:

- A 25 MHz crystal connected to XI, XO (Pins 15, 14), or an external 25 MHz clock source (oscillator) connected to XI.
- The CONFIG[2:0] strapping pins (Pins 27, 41, 40) set to 000 (default setting).

3.2.1 MII SIGNAL DEFINITION

[Table 3-1](#) describes the MII signals. Refer to Clause 22 of the IEEE 802.3 Specification for detailed information.

KSZ8081MLX

TABLE 3-1: MII SIGNAL DEFINITION

MII Signal Name	Direction with Respect to PHY, KSZ8081 Signal	Direction with Respect to MAC	Description
TXC	Output	Input	Transmit Clock (2.5 MHz for 10 Mbps; 25 MHz for 100 Mbps)
TXEN	Input	Output	Transmit Enable
TXD[3:0]	Input	Output	Transmit Data[3:0]
RXC	Output	Input	Receive Clock (2.5 MHz for 10 Mbps; 25 MHz for 100 Mbps)
RXDV	Output	Input	Receive Data Valid
RXD[3:0]	Output	Input	Receive Data[3:0]
RXER	Output	Input or not required	Receive Error
CRS	Output	Input	Carrier Sense
COL	Output	Input	Collision Detection

3.2.1.1 Transmit Clock (TXC)

TXC is sourced by the PHY. It is a continuous clock that provides the timing reference for TXEN and TXD[3:0].

TXC is 2.5 MHz for 10 Mbps operation and 25 MHz for 100 Mbps operation.

3.2.1.2 Transmit Enable (TXEN)

TXEN indicates that the MAC is presenting nibbles on TXD[3:0] for transmission. It is asserted synchronously with the first nibble of the preamble and remains asserted while all nibbles to be transmitted are presented on the MII. It is negated before the first TXC following the final nibble of a frame.

TXEN transitions synchronously with respect to TXC.

3.2.1.3 Transmit Data[3:0] (TXD[3:0])

When TXEN is asserted, TXD[3:0] are the data nibbles accepted by the PHY for transmission. TXD[3:0] is 00 to indicate idle when TXEN is de-asserted.

TXD[3:0] transitions synchronously with respect to TXC.

3.2.1.4 Receive Clock (RXC)

RXC provides the timing reference for RXDV, RXD[3:0], and RXER.

In 10 Mbps mode, RXC is recovered from the line while the carrier is active. RXC is derived from the PHY's reference clock when the line is idle or the link is down.

In 100 Mbps mode, RXC is continuously recovered from the line. If the link is down, RXC is derived from the PHY's reference clock.

RXC is 2.5 MHz for 10 Mbps operation and 25 MHz for 100 Mbps operation.

3.2.1.5 Receive Data Valid (RXDV)

RXDV is driven by the PHY to indicate that the PHY is presenting recovered and decoded nibbles on RXD[3:0].

In 10 Mbps mode, RXDV is asserted with the first nibble of the start-of-frame delimiter (SFD), 5D, and remains asserted until the end of the frame.

In 100 Mbps mode, RXDV is asserted from the first nibble of the preamble to the last nibble of the frame.

RXDV transitions synchronously with respect to RXC.

3.2.1.6 Receive Data[3:0] (RXD[3:0])

RXD[3:0] transitions synchronously with respect to RXC. For each clock period in which RXDV is asserted, RXD[3:0] transfers a nibble of recovered data from the PHY.

3.2.1.7 Receive Error (RXER)

RXER is asserted for one or more RXC periods to indicate that a symbol error (for example, a coding error that a PHY can detect that may otherwise be undetectable by the MAC sub-layer) was detected somewhere in the frame being transferred from the PHY.

RXER transitions synchronously with respect to RXC.

3.2.1.8 Carrier Sense (CRS)

CRS is asserted and de-asserted as follows:

In 10 Mbps mode, CRS assertion is based on the reception of valid preambles. CRS de-assertion is based on the reception of an end-of-frame (EOF) marker.

In 100 Mbps mode, CRS is asserted when a start-of-stream delimiter or /J/K symbol pair is detected. CRS is de-asserted when an end-of-stream delimiter or /T/R symbol pair is detected. Additionally, the PMA layer de-asserts CRS if IDLE symbols are received without /T/R.

3.2.1.9 Collision Detection (COL)

COL is asserted in half-duplex mode whenever the transmitter and receiver are simultaneously active on the line. This informs the MAC that a collision has occurred during its transmission to the PHY.

COL transitions asynchronously with respect to TXC and RXC.

3.2.2 MII SIGNAL DIAGRAM

The KSZ8081MLX MII pin connections to the MAC are shown in [Figure 3-2](#).

FIGURE 3-2: KSZ8081MLX MII INTERFACE

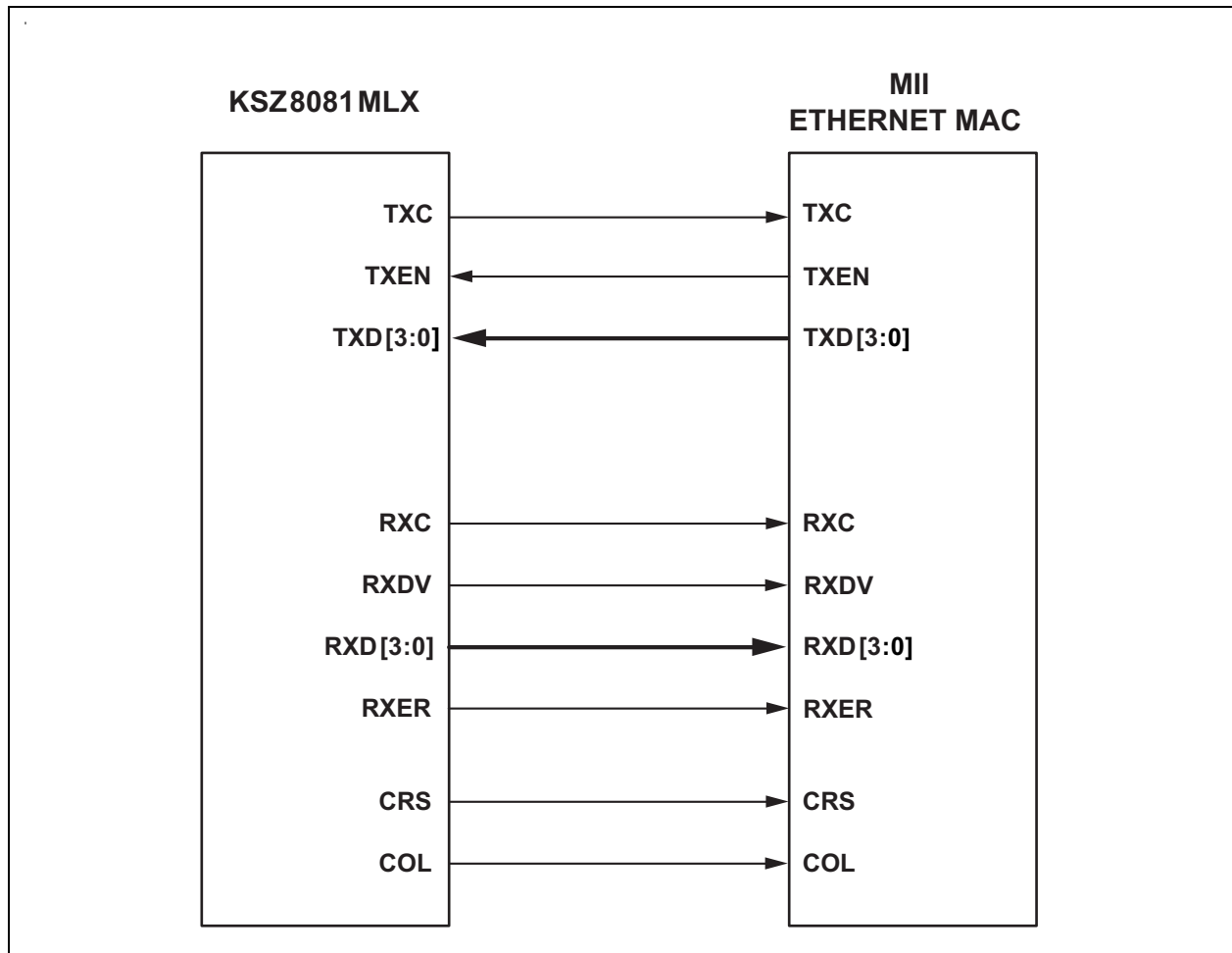

KSZ8081MLX

3.3 Back-to-Back Mode – 100 Mbps Copper Repeater

Two KSZ8081MLX devices can be connected back-to-back to form a 100BASE-TX to 100BASE-TX copper repeater.

FIGURE 3-3: KSZ8081MLX TO KSZ8081MLX BACK-TO-BACK COPPER REPEATER

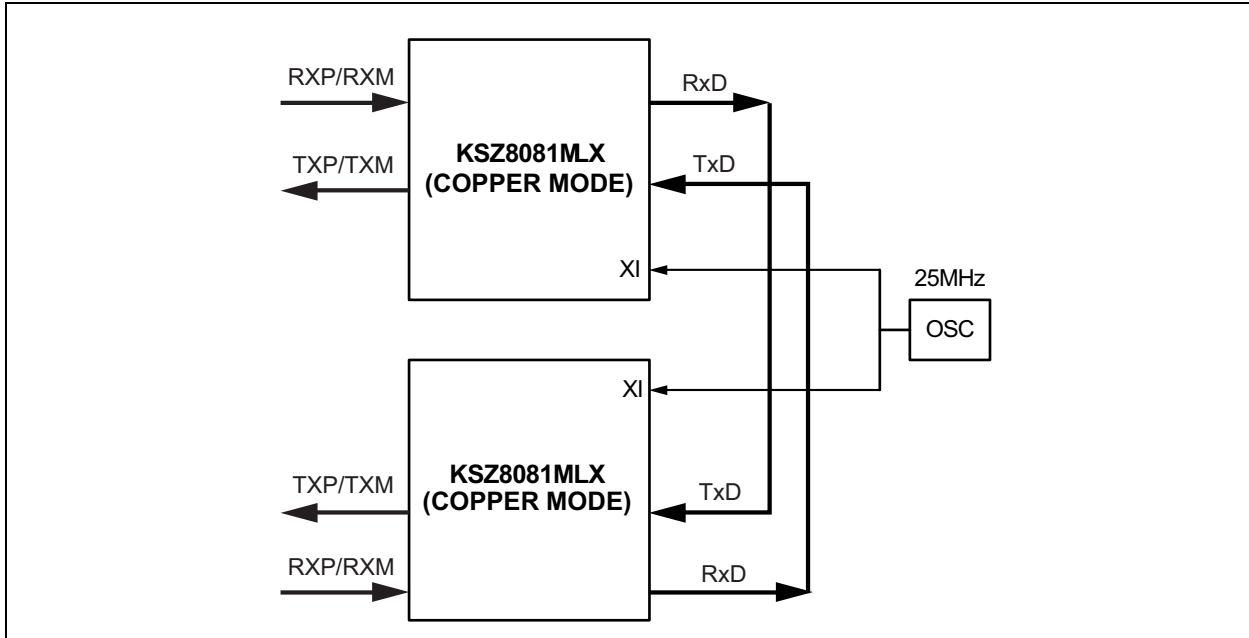

3.3.1 MII BACK-TO-BACK MODE

In MII back-to-back mode, a KSZ8081MLX interfaces with another KSZ8081MLX to provide a complete 100 Mbps copper repeater solution.

The KSZ8081MLX devices are configured to MII back-to-back mode after power-up or reset with the following:

- Strapping pin CONFIG[2:0] (Pins 27, 41, 40) set to 110.
- A common 25 MHz reference clock connected to XI (Pin 15) of both KSZ8081MLX devices.
- MII signals connected as shown in [Table 3-2](#).

TABLE 3-2: MII SIGNAL CONNECTION FOR MII BACK-TO-BACK MODE (100BASE-TX COPPER REPEATER)

KSZ8081MLX (100BASE-TX Copper) [Device 1]			KSZ8081MLX (100BASE-TX Copper) [Device 2]		
Pin Name	Pin Number	Pin Type	Pin Name	Pin Number	Pin Type
RXDV	27	Output	TXEN	34	Input
RXD3	20	Output	TXD3	39	Input
RXD2	21	Output	TXD2	38	Input
RXD1	22	Output	TXD1	36	Input
RXD0	23	Output	TXD0	35	Input
TXEN	34	Input	RXDV	27	Output
TXD3	39	Input	RXD3	20	Output
TXD2	38	Input	RXD2	21	Output
TXD1	36	Input	RXD1	22	Output
TXD0	35	Input	RXD0	23	Output

3.4 MII Management (MIIM) Interface

The KSZ8081MLX supports the IEEE 802.3 MII management interface, also known as the Management Data Input/Output (MDIO) interface. This interface allows an upper-layer device, such as a MAC processor, to monitor and control the state of the KSZ8081MLX. An external device with MIIM capability is used to read the PHY status and/or configure the PHY settings. More details about the MIIM interface can be found in Clause 22.2.4 of the IEEE 802.3 Specification.

The MIIM interface consists of the following:

- A physical connection that incorporates the clock line (MDC) and the data line (MDIO).
- A specific protocol that operates across the physical connection mentioned earlier, which allows the external controller to communicate with one or more PHY devices.
- A set of 16-bit MDIO registers. Registers [0:8] are standard registers, and their functions are defined in the IEEE 802.3 Specification. The additional registers are provided for expanded functionality. See the Register Map section for details.

As the default, the KSZ8081MLX supports unique PHY addresses 1 to 7, and broadcast PHY address 0. The latter is defined in the IEEE 802.3 Specification, and can be used to read/write to a single KSZ8081MLX device, or write to multiple KSZ8081MLX devices simultaneously.

PHY address 0 can optionally be disabled as the broadcast address by either hardware pin strapping (B-CAST_OFF, Pin 28) or software (Register 16h, Bit [9]), and assigned as a unique PHY address.

The PHYAD[2:0] strapping pins are used to assign a unique PHY address between 0 and 7 to each KSZ8081MLX device.

The MIIM interface can operate up to a maximum clock speed of 10 MHz MAC clock.

Table 3-3 shows the MII management frame format for the KSZ8081MLX.

TABLE 3-3: MII MANAGEMENT FRAME FORMAT FOR THE KSZ8081MLX

	Preamble	Start of Frame	Read/Write OP Code	PHY Address Bits[4:0]	REG Address Bits[4:0]	TA	Data Bits[15:0]	Idle
Read	32 1's	01	10	000AA	RRRRR	Z0	DDDDDDDD_DDDDDDDD	Z
Write	32 1's	01	01	000AA	RRRRR	10	DDDDDDDD_DDDDDDDD	Z

3.5 Interrupt (INTRP)

INTRP (Pin 32) is an optional interrupt signal that is used to inform the external controller that there has been a status update to the KSZ8081MLX PHY Register. Bits [15:8] of Register 1Bh are the interrupt control bits to enable and disable the conditions for asserting the INTRP signal. Bits [7:0] of Register 1Bh are the interrupt status bits to indicate which interrupt conditions have occurred. The interrupt status bits are cleared after reading Register 1Bh.

Bit [9] of Register 1Fh sets the interrupt level to active high or active low. The default is active low.

The MII management bus option gives the MAC processor complete access to the KSZ8081MLX control and status registers. Additionally, an interrupt pin eliminates the need for the processor to poll the PHY for status change.

3.6 HP Auto MDI/MDI-X

HP Auto MDI/MDI-X configuration eliminates the need to decide whether to use a straight cable or a crossover cable between the KSZ8081MLX and its link partner. This feature allows the KSZ8081MLX to use either type of cable to connect with a link partner that is in either MDI or MDI-X mode. The auto-sense function detects transmit and receive pairs from the link partner and assigns transmit and receive pairs of the KSZ8081MLX accordingly.

HP Auto MDI/MDI-X is enabled by default. It is disabled by writing a '1' to Register 1Fh, Bit [13]. MDI and MDI-X mode is selected by Register 1Fh, Bit [14] if HP Auto MDI/MDI-X is disabled.

An isolation transformer with symmetrical transmit and receive data paths is recommended to support Auto MDI/MDI-X.

Table 3-4 shows how the IEEE 802.3 Standard defines MDI and MDI-X.

KSZ8081MLX

TABLE 3-4: MDI/MDI-X PIN DESCRIPTION

MDI		MDI-X	
RJ-45 Pin	Signal	RJ-45 Pin	Signal
1	TX+	1	RX+
2	TX-	2	RX-
3	RX+	3	TX+
6	RX-	6	TX-

3.6.1 STRAIGHT CABLE

A straight cable connects an MDI device to an MDI-X device, or an MDI-X device to an MDI device. [Figure 3-4](#) shows a typical straight cable connection between a NIC card (MDI device) and a switch or hub (MDI-X device).

FIGURE 3-4: TYPICAL STRAIGHT CABLE CONNECTION

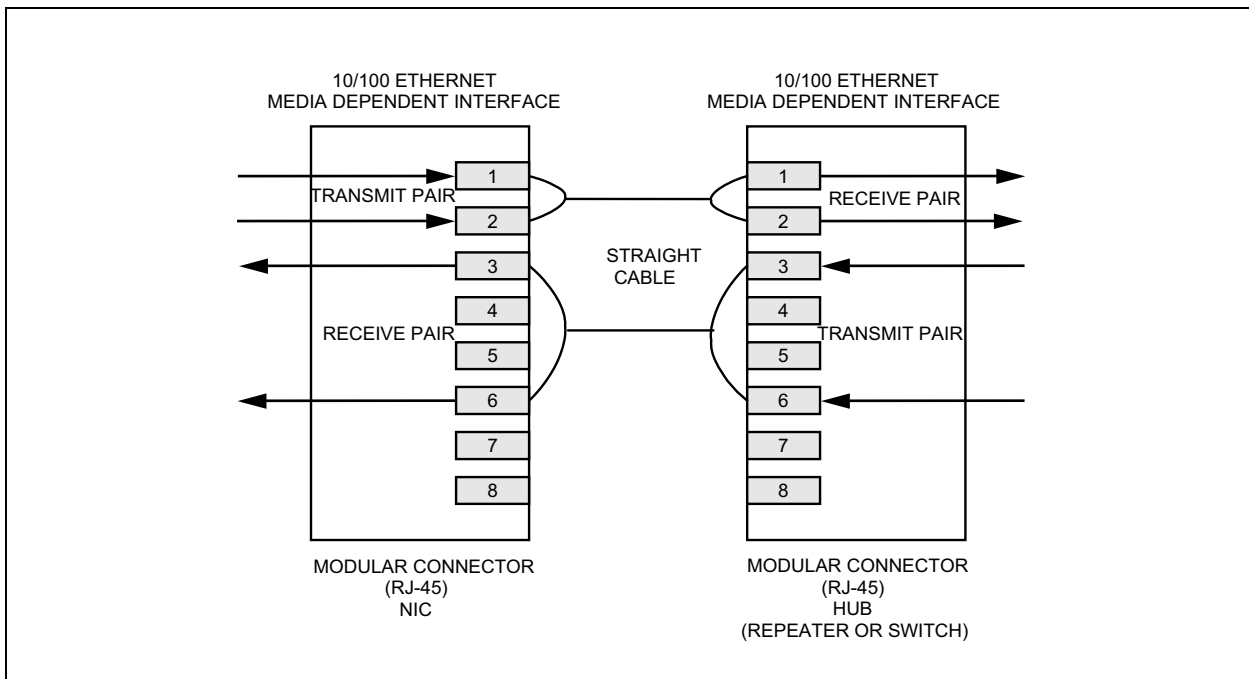

3.6.2 CROSSOVER CABLE

A crossover cable connects an MDI device to another MDI device, or an MDI-X device to another MDI-X device. [Figure 3-5](#) shows a typical crossover cable connection between two switches or hubs (two MDI-X devices).

FIGURE 3-5: TYPICAL CROSSOVER CABLE CONNECTION

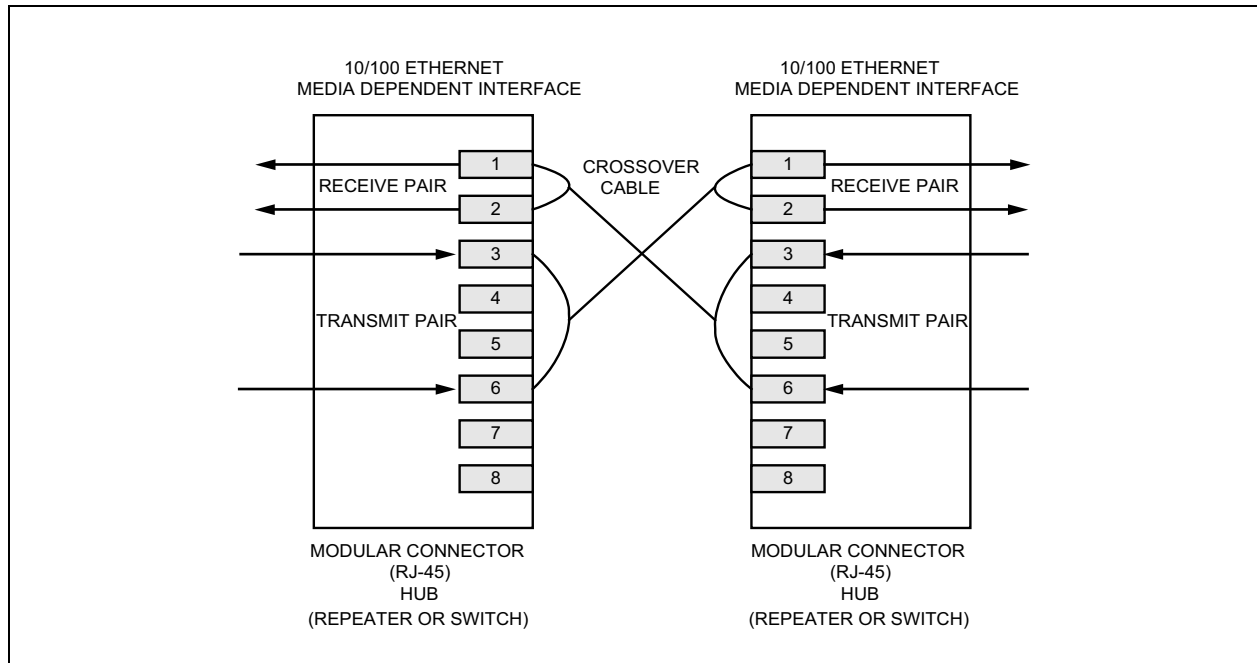

3.7 Loopback Mode

The KSZ8081MLX supports the following loopback operations to verify analog and/or digital data paths.

- Local (digital) loopback
- Remote (analog) loopback

3.7.1 LOCAL (DIGITAL) LOOPBACK

This loopback mode checks the MII transmit and receive data paths between the KSZ8081MLX and the external MAC, and is supported for both speeds (10/100 Mbps) at full-duplex.

The loopback data path is shown in [Figure 3-6](#).

1. The MII MAC transmits frames to the KSZ8081MLX.
2. Frames are wrapped around inside the KSZ8081MLX.
3. The KSZ8081MLX transmits frames back to the MII MAC.

FIGURE 3-6: LOCAL (DIGITAL) LOOPBACK

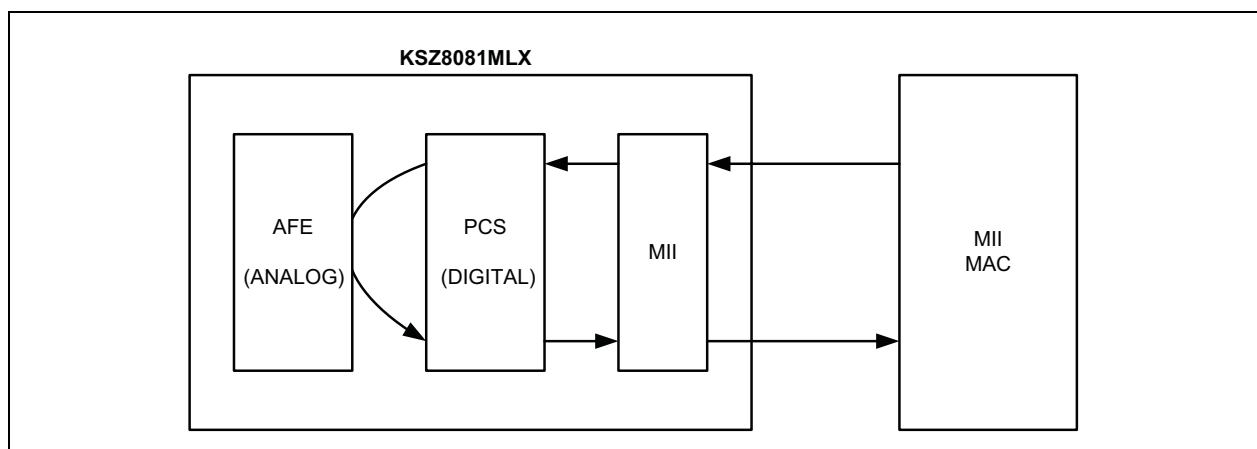

KSZ8081MLX

The following programming action and register settings are used for local loopback mode:

For 10/100 Mbps loopback:

Set Register 0h,

Bit [14] = 1 // Enable local loopback mode

Bit [13] = 0/1 // Select 10 Mbps/100 Mbps speed

Bit [12] = 0 // Disable auto-negotiation

Bit [8] = 1 // Select full-duplex mode

3.7.2 REMOTE (ANALOG) LOOPBACK

This loopback mode checks the line (differential pairs, transformer, RJ-45 connector, Ethernet cable) transmit and receive data paths between the KSZ8081MLX and its link partner, and is supported for 100BASE-TX full-duplex mode only.

The loopback data path is shown in [Figure 3-7](#).

1. The Fast Ethernet (100BASE-TX) PHY link partner transmits frames to the KSZ8081MLX.
2. Frames are wrapped around inside the KSZ8081MLX.
3. The KSZ8081MLX transmits frames back to the Fast Ethernet (100BASE-TX) PHY link partner.

FIGURE 3-7: REMOTE (ANALOG) LOOPBACK

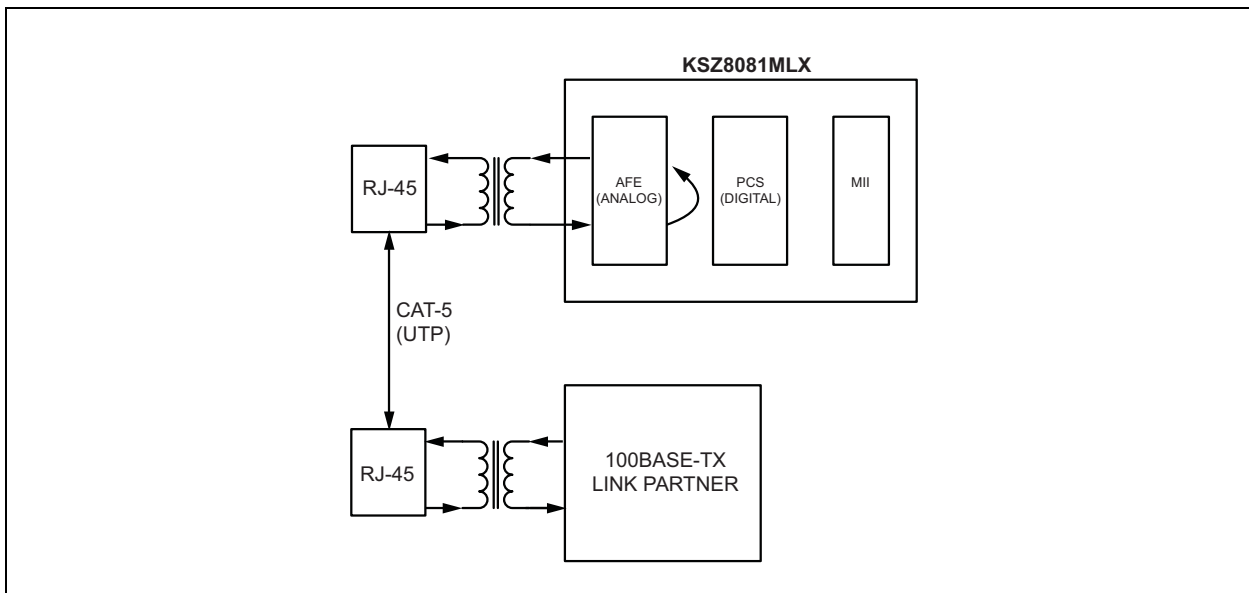

The following programming steps and register settings are used for remote loopback mode:

1. Set Register 0h,

Bits [13] = 1 // Select 100 Mbps speed

Bit [12] = 0 // Disable auto-negotiation

Bit [8] = 1 // Select full-duplex mode

Or just auto-negotiate and link up at 100BASE-TX full-duplex mode with the link partner.

2. Set Register 1Fh,

Bit [2] = 1 // Enable remote loopback mode

3.8 LinkMD[®] Cable Diagnostic

The LinkMD function uses time-domain reflectometry (TDR) to analyze the cabling plant for common cabling problems. These include open circuits, short circuits, and impedance mismatches.

LinkMD works by sending a pulse of known amplitude and duration down the MDI or MDI-X pair, then analyzing the shape of the reflected signal to determine the type of fault. The time duration for the reflected signal to return provides the approximate distance to the cabling fault. The LinkMD function processes this TDR information and presents it as a numerical value that can be translated to a cable distance.

LinkMD is initiated by accessing Register 1Dh, the LinkMD Control/Status register, in conjunction with Register 1Fh, the PHY Control 2 register. The latter register is used to disable Auto MDI/MDI-X and to select either MDI or MDI-X as the cable differential pair for testing.

3.8.1 USAGE

The following is a sample procedure for using LinkMD with Registers 1Dh and 1Fh:

1. Disable auto MDI/MDI-X by writing a '1' to Register 1Fh, bit [13].
2. Start cable diagnostic test by writing a '1' to Register 1Dh, bit [15]. This enable bit is self-clearing.
3. Wait (poll) for Register 1Dh, bit [15] to return a '0', and indicating cable diagnostic test is completed.
4. Read cable diagnostic test results in Register 1Dh, bits [14:13]. The results are as follows:
 - 00 = normal condition (valid test)
 - 01 = open condition detected in cable (valid test)
 - 10 = short condition detected in cable (valid test)
 - 11 = cable diagnostic test failed (invalid test)

The '11' case, invalid test, occurs when the device is unable to shut down the link partner. In this instance, the test is not run because it would be impossible for the device to determine if the detected signal is a reflection of the signal generated or a signal from another source.

5. Get distance to fault by concatenating Register 1Dh, bits [8:0] and multiplying the result by a constant of 0.38. The distance to the cable fault can be determined by the following formula:

EQUATION 3-1:

$$D(\text{Distance to cable fault in meters}) = 0.38 \times (\text{Register 1Dh, bits}[8:0])$$

Concatenated value of Registers 1Dh bits [8:0] should be converted to decimal before multiplying by 0.38.

The constant (0.38) may be calibrated for different cabling conditions, including cables with a velocity of propagation that varies significantly from the norm.

3.9 NAND Tree Support

The KSZ8081MLX provides parametric NAND tree support for fault detection between chip I/Os and board. The NAND tree is a chain of nested NAND gates in which each KSZ8081MLX digital I/O (NAND tree input) pin is an input to one NAND gate along the chain. At the end of the chain, the CRS/CONFIG1 pin provides the output for the nested NAND gates.

The NAND tree test process includes:

- Enabling NAND tree mode
- Pulling all NAND tree input pins high
- Driving each NAND tree input pin low, sequentially, according to the NAND tree pin order
- Checking the NAND tree output to make sure there is a toggle high-to-low or low-to-high for each NAND tree input driven low

Table 3-5 lists the NAND tree pin order.

KSZ8081MLX

TABLE 3-5: NAND TREE TEST PIN ORDER FOR KSZ8081MLX

Pin Number	Pin Name	NAND Tree Description
18	MDIO	Input
19	MDC	Input
20	RXD3	Input
21	RXD2	Input
22	RXD1	Input
23	RXD0	Input
27	RXDV	Input
28	RXC	Input
29	RXER	Input
32	INTRP	Input
33	TXC	Input
34	TXEN	Input
35	TXD0	Input
36	TXD1	Input
38	TXD2	Input
39	TXD3	Input
42	LED0	Input
43	LED1	Input
40	COL	Input
41	CRS	Output

3.9.1 NAND TREE I/O TESTING

Use the following procedure to check for faults on the KSZ8081MLX digital I/O pin connections to the board:

1. Enable NAND tree mode using either a hardware strap-in pin (NAND_Tree#, Pin 32) or software (Register 16h, Bit [5]). Pin 44 TEST/NC has to use a pull-up resistor for normal NAND tree testing.
2. Use board logic to drive all KSZ8081MLX NAND tree input pins high.
3. Use board logic to drive each NAND tree input pin, in KSZ8081MLX NAND tree pin order, as follows:
 - a) Toggle the first pin (MDIO) from high to low, and verify that the CRS/CONFIG1 pin switches from high to low to indicate that the first pin is connected properly.
 - b) Leave the first pin (MDIO) low.
 - c) Toggle the second pin (MDC) from high to low, and verify that the CRS/CONFIG1 pin switches from low to high to indicate that the second pin is connected properly.
 - d) Leave the first pin (MDIO) and the second pin (MDC) low.
 - e) Toggle the third pin from high to low, and verify that the CRS/CONFIG1 pin switches from high-to-low to indicate that the third pin is connected properly.
 - f) Continue with this sequence until all KSZ8081MLX NAND tree input pins have been toggled.

Each KSZ8081MLX NAND tree input pin must cause the CRS/CONFIG1 output pin to toggle high-to-low or low-to-high to indicate a good connection. If the CRS pin fails to toggle when the KSZ8081MLX input pin toggles from high to low, the input pin has a fault.

3.10 Power Management

The KSZ8081MLX incorporates a number of power-management modes and features that provide methods to consume less energy. These are discussed in the following sections.

3.10.1 POWER-SAVING MODE

Power-saving mode is used to reduce the transceiver power consumption when the cable is unplugged. It is enabled by writing a '1' to Register 1Fh, Bit [10], and is in effect when auto-negotiation mode is enabled and the cable is disconnected (no link).

In this mode, the KSZ8081MLX shuts down all transceiver blocks, except for the transmitter, energy detect, and PLL circuits.

By default, power-saving mode is disabled after power-up.

3.10.2 ENERGY-DETECT POWER-DOWN MODE

Energy-detect power-down (EDPD) mode is used to further reduce transceiver power consumption when the cable is unplugged. It is enabled by writing a '0' to Register 18h, Bit [11], and is in effect when auto-negotiation mode is enabled and the cable is disconnected (no link).

EDPD mode works with the PLL off (set by writing a '1' to Register 10h, Bit [4] to automatically turn the PLL off in EDPD mode) to turn off all KSZ8081MLX transceiver blocks, except for the transmitter and energy-detect circuits.

Power can be reduced further by extending the time interval between transmissions of link pulses to check for the presence of a link partner. The periodic transmission of link pulses is needed to ensure two link partners in the same low-power state, with Auto MDI/MDI-X disabled, can wake up when the cable is connected between them.

By default, energy-detect power-down mode is disabled after power-up.

3.10.3 POWER-DOWN MODE

Power-down mode is used to power down the KSZ8081MLX device when it is not in use after power-up. It is enabled by writing a '1' to Register 0h, Bit [11].

In this mode, the KSZ8081MLX disables all internal functions except the MII management interface. The KSZ8081MLX exits (disables) power-down mode after Register 0h, Bit [11] is set back to '0'.

3.10.4 SLOW-OSCILLATOR MODE

Slow-oscillator mode is used to disconnect the input reference crystal/clock on XI (Pin 15) and select the on-chip slow oscillator when the KSZ8081MLX device is not in use after power-up. It is enabled by writing a '1' to Register 11h, Bit [5].

Slow-oscillator mode works in conjunction with power-down mode to put the KSZ8081MLX device in the lowest power state with all internal functions disabled except the MII management interface. To properly exit this mode and return to normal PHY operation, use the following programming sequence:

1. Disable slow-oscillator mode by writing a '0' to Register 11h, Bit [5].
2. Disable power-down mode by writing a '0' to Register 0h, Bit [11].
3. Initiate software reset by writing a '1' to Register 0h, Bit [15].

KSZ8081MLX

3.11 Reference Circuit for Power and Ground Connections

The KSZ8081MLX is a single 3.3V supply device with a built-in regulator to supply the 1.2V core. The power and ground connections are shown in [Figure 3-8](#) and [Table 3-6](#) for 3.3V V_{DDIO} .

FIGURE 3-8: KSZ8081MLX POWER AND GROUND CONNECTIONS

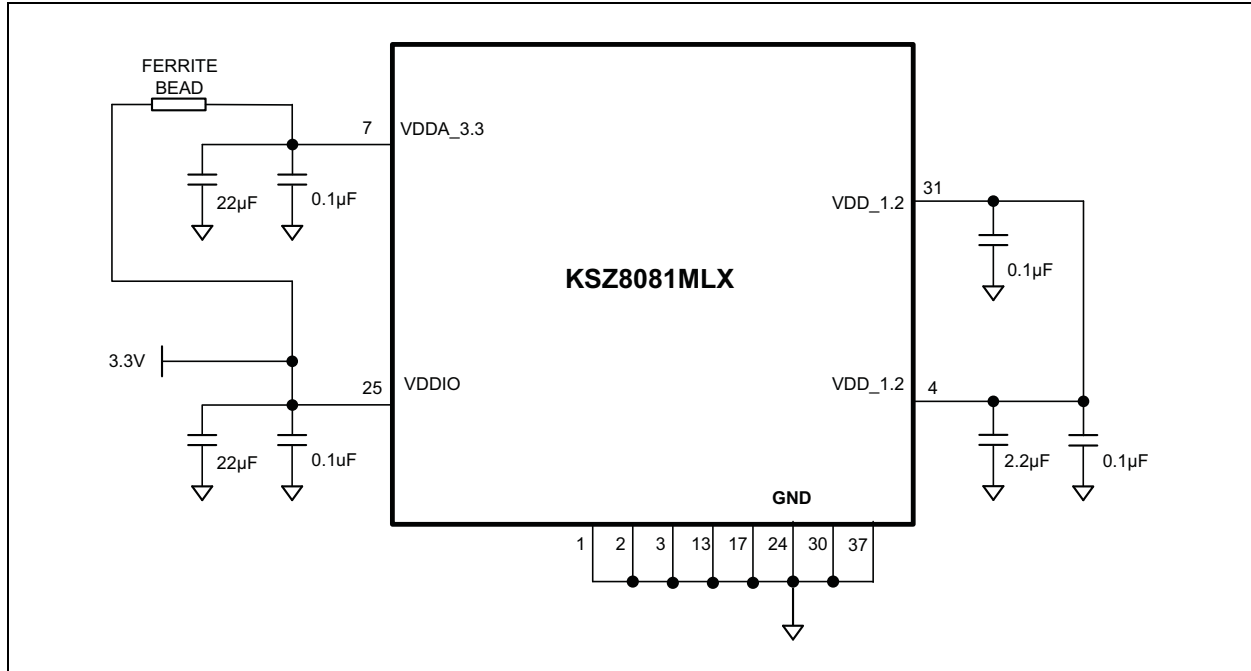

TABLE 3-6: KSZ8081MLX POWER PIN DESCRIPTION

Power Pin	Pin Number	Description
VDD_1.2	4	Connect with Pin 31 by power trace or plane. Decouple with 2.2 μ F and 0.1 μ F capacitors to ground.
VDDA_3.3	7	Connect to board's 3.3V supply through a ferrite bead. Decouple with 22 μ F and 0.1 μ F capacitors to ground.
VDDIO	25	Connect to board's 3.3V supply for 3.3V V_{DDIO} . Decouple with 22 μ F and 0.1 μ F capacitors to ground.
VDD_1.2	31	Connect with Pin 4 by power trace or plane. Decouple with 0.1 μ F capacitor to ground.

3.12 Typical Current/Power Consumption

[Table 3-7](#), [Table 3-8](#), and [Table 3-9](#) show typical values for current consumption by the transceiver ($V_{DDA_3.3}$) and digital I/O (V_{DDIO}) power pins and typical values for power consumption by the KSZ8081MLX device for the indicated nominal operating voltages. These current and power consumption values include the transmit driver current and on-chip regulator current for the 1.2V core.

TABLE 3-7: TYPICAL CURRENT/POWER CONSUMPTION ($V_{DDA_3.3} = 3.3V$, $V_{DDIO} = 3.3V$)

Condition	3.3V Transceiver ($V_{DDA_3.3}$)	3.3V Digital I/Os (V_{DDIO})	Total Chip Power
100BASE-TX Link-up (no traffic)	34 mA	12 mA	152 mW
100BASE-TX Full-duplex @ 100% utilization	34 mA	13 mA	155 mW
10BASE-T Link-up (no traffic)	14 mA	11 mA	82.5 mW
10BASE-T Full-duplex @ 100% utilization	30 mA	11 mA	135 mW

TABLE 3-7: TYPICAL CURRENT/POWER CONSUMPTION (VDDA_3.3 = 3.3V, VDDIO = 3.3V)

Condition	3.3V Transceiver (VDDA_3.3)	3.3V Digital I/Os (VDDIO)	Total Chip Power
Power-saving mode (Reg. 1Fh, Bit [10] = 1)	14 mA	10 mA	79.2 mW
EDPD mode (Reg. 18h, Bit [11] = 0)	10 mA	10 mA	66 mW
EDPD mode (Reg. 18h, Bit [11] = 0) and PLL off (Reg. 10h, Bit [4] = 1)	3.77 mA	1.54 mA	1.75 mW
Software power-down mode (Reg. 0h, Bit [11] = 1)	2.59 mA	1.51 mA	13.5 mW
Software power-down mode (Reg. 0h, Bit [11] = 1) and slow-oscillator mode (Reg. 11h, Bit [5] = 1)	1.36 mA	0.45 mA	5.97 mW

TABLE 3-8: TYPICAL CURRENT/POWER CONSUMPTION (VDDA_3.3 = 3.3V, VDDIO = 2.5V)

Condition	3.3V Transceiver (VDDA_3.3)	2.5V Digital I/Os (VDDIO)	Total Chip Power
100BASE-TX Link-up (no traffic)	34 mA	11 mA	140 mW
100BASE-TX Full-duplex @ 100% utilization	34 mA	12 mA	142 mW
10BASE-T Link-up (no traffic)	15 mA	10 mA	74.5 mW
10BASE-T Full-duplex @ 100% utilization	27 mA	10 mA	114 mW
Power-saving mode (Reg. 1Fh, Bit [10] = 1)	15 mA	10 mA	74.5 mW
EDPD mode (Reg. 18h, Bit [11] = 0)	11 mA	10 mA	61.3 mW
EDPD mode (Reg. 18h, Bit [11] = 0) and PLL off (Reg. 10h, Bit [4] = 1)	3.55 mA	1.35 mA	15.1 mW
Software power-down mode (Reg. 0h, Bit [11] = 1)	2.29 mA	1.34 mA	10.9 mW
Software power-down mode (Reg. 0h, Bit [11] = 1) and slow-oscillator mode (Reg. 11h, Bit [5] = 1)	1.15 mA	0.29 mA	4.52 mW

TABLE 3-9: TYPICAL CURRENT/POWER CONSUMPTION (VDDA_3.3 = 3.3V, VDDIO = 1.8V)

Condition	3.3V Transceiver (VDDA_3.3)	1.8V Digital I/Os (VDDIO)	Total Chip Power
100BASE-TX Link-up (no traffic)	34 mA	11 mA	132 mW
100BASE-TX Full-duplex @ 100% utilization	34 mA	12 mA	134 mW
10BASE-T Link-up (no traffic)	15 mA	9 mA	65.7 mW
10BASE-T Full-duplex @ 100% utilization	27 mA	9 mA	105 mW
Power-saving mode (Reg. 1Fh, Bit [10] = 1)	15 mA	9 mA	65.7 mW
EDPD mode (Reg. 18h, Bit [11] = 0)	11 mA	9 mA	52.5 mW
EDPD mode (Reg. 18h, Bit [11] = 0) and PLL off (Reg. 10h, Bit [4] = 1)	4.05 mA	1.21 mA	15.5 mW
Software power-down mode (Reg. 0h, Bit [11] = 1)	2.79 mA	1.21 mA	11.4 mW
Software power-down mode (Reg. 0h, Bit [11] = 1) and slow-oscillator mode (Reg. 11h, Bit [5] = 1)	1.65 mA	0.19 mA	5.79 mW

KSZ8081MLX

4.0 REGISTER DESCRIPTIONS

This chapter describes the various control and status registers (CSRs).

4.1 Register Map

TABLE 4-1: REGISTERS SUPPORTED BY KSZ8081MLX

Register Number (hex)	Description
0h	Basic Control
1h	Basic Status
2h	PHY Identifier 1
3h	PHY Identifier 2
4h	Auto-Negotiation Advertisement
5h	Auto-Negotiation Link Partner Ability
6h	Auto-Negotiation Expansion
7h	Auto-Negotiation Next Page
8h	Link Partner Next Page Ability
9h	Reserved
10h	Digital Reserved Control
11h	AFE Control 1
12h - 14h	Reserved
15h	RXER Counter
16h	Operation Mode Strap Override
17h	Operation Mode Strap Status
18h	Expanded Control
19h - 1Ah	Reserved
1Bh	Interrupt Control/Status
1Ch	Reserved
1Dh	LinkMD Control/Status
1Eh	PHY Control 1
1Fh	PHY Control 2

4.2 Register Descriptions

TABLE 4-2: REGISTER DESCRIPTIONS

Address	Name	Description	Mode Note 4-1	Default
Register 0h – Basic Control				
0.15	Reset	1 = Software reset 0 = Normal operation This bit is self-cleared after a '1' is written to it.	RW/SC	0
0.14	Loopback	1 = Loopback mode 0 = Normal operation	RW	0
0.13	Speed Select	1 = 100 Mbps 0 = 10 Mbps This bit is ignored if auto-negotiation is enabled (Register 0.12 = 1).	RW	Set by the SPEED strapping pin. See the Strap-In Options section for details.

TABLE 4-2: REGISTER DESCRIPTIONS (CONTINUED)

Address	Name	Description	Mode Note 4-1	Default
0.12	Auto-Negotiation Enable	1 = Enable auto-negotiation process 0 = Disable auto-negotiation process If enabled, the auto-negotiation result overrides the settings in Registers 0.13 and 0.8.	RW	Set by the NWAYEN strapping pin. See the Strap-In Options section for details.
0.11	Power-Down	1 = Power-down mode 0 = Normal operation If software reset (Register 0.15) is used to exit power-down mode (Register 0.11 = 1), two software reset writes (Register 0.15 = 1) are required. The first write clears power-down mode; the second write resets the chip and re-latches the pin strapping pin values.	RW	0
0.10	Isolate	1 = Electrical isolation of PHY from MII 0 = Normal operation	RW	Set by the ISO strapping pin. See the Strap-In Options section for details.
0.9	Restart Auto-Negotiation	1 = Restart auto-negotiation process 0 = Normal operation. This bit is self-cleared after a '1' is written to it.	RW/SC	0
0.8	Duplex Mode	1 = Full-duplex 0 = Half-duplex	RW	The inverse of the DUPLEX strapping pin value. See the Strap-In Options section for details.
0.7	Collision Test	1 = Enable COL test 0 = Disable COL test	RW	0
0.6:0	Reserved	Reserved	RO	000_0000
Register 1h - Basic Status				
1.15	100BASE-T4	1 = T4 capable 0 = Not T4 capable	RO	0
1.14	100BASE-TX Full-Duplex	1 = Capable of 100 Mbps full-duplex 0 = Not capable of 100 Mbps full-duplex	RO	1
1.13	100BASE-TX Half-Duplex	1 = Capable of 100 Mbps half-duplex 0 = Not capable of 100 Mbps half-duplex	RO	1
1.12	10BASE-T Full-Duplex	1 = Capable of 10 Mbps full-duplex 0 = Not capable of 10 Mbps full-duplex	RO	1
1.11	10BASE-T Half-Duplex	1 = Capable of 10 Mbps half-duplex 0 = Not capable of 10 Mbps half-duplex	RO	1
1.10:7	Reserved	Reserved	RO	000_0
1.6	No Preamble	1 = Preamble suppression 0 = Normal preamble	RO	1
1.5	Auto-Negotiation Complete	1 = Auto-negotiation process completed 0 = Auto-negotiation process not completed	RO	0
1.4	Remote Fault	1 = Remote fault 0 = No remote fault	RO/LH	0
1.3	Auto-Negotiation Ability	1 = Can perform auto-negotiation 0 = Cannot perform auto-negotiation	RO	1

KSZ8081MLX

TABLE 4-2: REGISTER DESCRIPTIONS (CONTINUED)

Address	Name	Description	Mode Note 4-1	Default
1.2	Link Status	1 = Link is up 0 = Link is down	RO/LL	0
1.1	Jabber Detect	1 = Jabber detected 0 = Jabber not detected (default is low)	RO/LH	0
1.0	Extended Capability	1 = Supports extended capability registers	RO	1
Register 2h - PHY Identifier 1				
2.15:0	PHY ID Number	Assigned to the 3rd through 18th bits of the Organizationally Unique Identifier (OUI). KENDIN Communication's OUI is 0010A1 (hex).	RO	0022h
Register 3h - PHY Identifier 2				
3.15:10	PHY ID Number	Assigned to the 19th through 24th bits of the Organizationally Unique Identifier (OUI). KENDIN Communication's OUI is 0010A1 (hex).	RO	0001_01
3.9:4	Model Number	Six-bit manufacturer's model number	RO	01_0110
3.3:0	Revision Number	Four-bit manufacturer's revision number	RO	Indicates silicon revision.
Register 4h - Auto-Negotiation Advertisement				
4.15	Next Page	1 = Next page capable 0 = No next page capability Note: Recommend to set this bit to '0'.	RW	1
4.14	Reserved	Reserved	RO	0
4.13	Remote Fault	1 = Remote fault supported 0 = No remote fault	RW	0
4.12	Reserved	Reserved	RO	0
4.11:10	Pause	[00] = No pause [10] = Asymmetric pause [01] = Symmetric pause [11] = Asymmetric and symmetric pause	RW	00
4.9	100BASE-T4	1 = T4 capable 0 = No T4 capability	RO	0
4.8	100BASE-TX Full-Duplex	1 = 100 Mbps full-duplex capable 0 = No 100 Mbps full-duplex capability	RW	Set by the SPEED strapping pin. See the Strap-In Options section for details.
4.7	100BASE-TX Half-Duplex	1 = 100 Mbps half-duplex capable 0 = No 100 Mbps half-duplex capability	RW	Set by the SPEED strapping pin. See the Strap-In Options section for details.
4.6	10BASE-T Full-Duplex	1 = 10 Mbps full-duplex capable 0 = No 10 Mbps full-duplex capability	RW	1
4.5	10BASE-T Half-Duplex	1 = 10 Mbps half-duplex capable 0 = No 10 Mbps half-duplex capability	RW	1
4.4:0	Selector Field	[00001] = IEEE 802.3	RW	0_0001

TABLE 4-2: REGISTER DESCRIPTIONS (CONTINUED)

Address	Name	Description	Mode Note 4-1	Default
Register 5h - Auto-Negotiation Link Partner Ability				
5.15	Next Page	1 = Next page capable 0 = No next page capability	RO	0
5.14	Acknowledge	1 = Link code word received from partner 0 = Link code word not yet received	RO	0
5.13	Remote Fault	1 = Remote fault detected 0 = No remote fault	RO	0
5.12	Reserved	Reserved	RO	0
5.11:10	Pause	[00] = No pause [10] = Asymmetric pause [01] = Symmetric pause [11] = Asymmetric and symmetric pause	RO	00
5.9	100BASE-T4	1 = T4 capable 0 = No T4 capability	RO	0
5.8	100BASE-TX Full-Duplex	1 = 100 Mbps full-duplex capable 0 = No 100 Mbps full-duplex capability	RO	0
5.7	100BASE-TX Half-Duplex	1 = 100 Mbps half-duplex capable 0 = No 100 Mbps half-duplex capability	RO	0
5.6	10BASE-T Full-Duplex	1 = 10 Mbps full-duplex capable 0 = No 10 Mbps full-duplex capability	RO	0
5.5	10BASE-T Half-Duplex	1 = 10 Mbps half-duplex capable 0 = No 10 Mbps half-duplex capability	RO	0
5.4:0	Selector Field	[00001] = IEEE 802.3	RO	0_0001
Register 6h - Auto-Negotiation Expansion				
6.15:5	Reserved	Reserved	RO	0000_0000_000
6.4	Parallel Detection Fault	1 = Fault detected by parallel detection 0 = No fault detected by parallel detection	RO/LH	0
6.3	Link Partner Next Page Able	1 = Link partner has next page capability 0 = Link partner does not have next page capability	RO	0
6.2	Next Page Able	1 = Local device has next page capability 0 = Local device does not have next page capability	RO	1
6.1	Page Received	1 = New page received 0 = New page not received yet	RO/LH	0
6.0	Link Partner Auto-Negoti- ation Able	1 = Link partner has auto-negotiation capability 0 = Link partner does not have auto-negotiation capability	RO	0
Register 7h - Auto-Negotiation Next Page				
7.15	Next Page	1 = Additional next pages will follow 0 = Last page	RW	0
7.14	Reserved	Reserved	RO	0
7.13	Message Page	1 = Message page 0 = Unformatted page	RW	1
7.12	Acknowl- edge2	1 = Will comply with message 0 = Cannot comply with message	RW	0

KSZ8081MLX

TABLE 4-2: REGISTER DESCRIPTIONS (CONTINUED)

Address	Name	Description	Mode Note 4-1	Default
7.11	Toggle	1 = Previous value of the transmitted link code word equaled logic 1 0 = Logic 0	RO	0
7.10:0	Message Field	11-bit wide field to encode 2048 messages	RW	000_0000_0001
Register 8h - Link Partner Next Page Ability				
8.15	Next Page	1 = Additional next pages will follow 0 = Last page	RO	0
8.14	Acknowledge	1 = Successful receipt of link word 0 = No successful receipt of link word	RO	0
8.13	Message Page	1 = Message page 0 = Unformatted page	RO	0
8.12	Acknowledge2	1 = Can act on the information 0 = Cannot act on the information	RO	0
8.11	Toggle	1 = Previous value of transmitted link code word equal to logic 0 0 = Previous value of transmitted link code word equal to logic 1	RO	0
8.10:0	Message Field	11-bit wide field to encode 2048 messages	RO	000_0000_0000
Register 10h – Digital Reserved Control				
10.15:5	Reserved	Reserved	RW	0000_0000_000
10.4	PLL Off	1 = Turn PLL off automatically in EDPD mode 0 = Keep PLL on in EDPD mode. See also Register 18h, Bit [11] for EDPD mode	RW	0
10.3:0	Reserved	Reserved	RW	0000
Register 11h – AFE Control 1				
11.15:6	Reserved	Reserved	RW	0000_0000_00
11.5	Slow-Oscillator Mode Enable	Slow-oscillator mode is used to disconnect the input reference crystal/clock on the XI pin and select the on-chip slow oscillator when the KSZ8081MLX device is not in use after power-up. 1 = Enable 0 = Disable This bit automatically sets software power-down to the analog side when enabled.	RW	0
11.4:0	Reserved	Reserved	RW	0_0000
Register 15h – RXER Counter				
15.15:0	RXER Counter	Receive error counter for symbol error frames	RO/SC	0000h
Register 16h – Operation Mode Strap Override				
16.15	Reserved Factory Mode	0 = Normal operation 1 = Factory test mode If TXC (Pin 33) latches in a pull-up value at the de-assertion of reset, write a '0' to this bit to clear Reserved Factory Mode.	RW	0 Set by the pull-up / pull-down value of TXC (Pin 33).
16.14:11	Reserved	Reserved	RW	000_0
16.10	Reserved	Reserved	RO	0

TABLE 4-2: REGISTER DESCRIPTIONS (CONTINUED)

Address	Name	Description	Mode Note 4-1	Default
16.9	B-CAST_OFF Override	1 = Override strap-in for B-CAST_OFF If bit is '1', PHY Address 0 is non-broadcast.	RW	0
16.8	Reserved	Reserved	RW	0_0
16.7	MII B-to-B Override	1 = Override strap-in for MII back-to-back mode (also set Bit 1 of this register to '1')	RW	0
16.6	Reserved	Reserved	RW	0
16.5	NAND Tree Override	1 = Override strap-in for NAND tree mode	RW	0
16.4:1	Reserved	Reserved	RW	0_000
16.0	MII Override	1 = Override strap-in for MII mode	RW	1
Register 17h - Operation Mode Strap Status				
17.15:13	PHYAD[2:0] Strap-In Status	[000] = Strap to PHY Address 0 [001] = Strap to PHY Address 1 [010] = Strap to PHY Address 2 [011] = Strap to PHY Address 3 [100] = Strap to PHY Address 4 [101] = Strap to PHY Address 5 [110] = Strap to PHY Address 6 [111] = Strap to PHY Address 7	RO	—
17.12:10	Reserved	Reserved	RO	—
17.9	B-CAST_OFF Strap-In Status	1 = Strap to B-CAST_OFF If bit is '1', PHY Address 0 is non-broadcast.	RO	—
17.8	Reserved	Reserved	RO	—
17.7	MII B-to-B Strap-In Status	1 = Strap to MII back-to-back mode	RO	—
17.6	Reserved	Reserved	RO	—
17.5	NAND Tree Strap-In Status	1 = Strap to NAND tree mode	RO	—
17.4:1	Reserved	Reserved	RO	—
17.0	MII Strap-In Status	1 = Strap to MII mode	RO	—
Register 18h - Expanded Control				
18.15:12	Reserved	Reserved	RW	0000
18.11	EDPD Disabled	Energy-detect power-down mode 1 = Disable 0 = Enable See also Register 10h, Bit [4] for PLL off.	RW	1
18.10	100BASE-TX Latency	1 = MII output is random latency 0 = MII output is fixed latency For both settings, all bytes of received preamble are passed to the MII output.	RW	0
18.9:7	Reserved	Reserved	RW	00_0

KSZ8081MLX

TABLE 4-2: REGISTER DESCRIPTIONS (CONTINUED)

Address	Name	Description	Mode Note 4-1	Default
18.6	10BASE-T Preamble Restore	1 = Restore received preamble to MII output 0 = Remove all seven bytes of preamble before sending frame (starting with SFD) to MII output	RW	0
18.5:0	Reserved	Reserved	RW	00_0000
Register 1Bh – Interrupt Control/Status				
1B.15	Jabber Interrupt Enable	1 = Enable jabber interrupt 0 = Disable jabber interrupt	RW	0
1B.14	Receive Error Interrupt Enable	1 = Enable receive error interrupt 0 = Disable receive error interrupt	RW	0
1B.13	Page Received Interrupt Enable	1 = Enable page received interrupt 0 = Disable page received interrupt	RW	0
1B.12	Parallel Detect Fault Interrupt Enable	1 = Enable parallel detect fault interrupt 0 = Disable parallel detect fault interrupt	RW	0
1B.11	Link Partner Acknowledge Interrupt Enable	1 = Enable link partner acknowledge interrupt 0 = Disable link partner acknowledge interrupt	RW	0
1B.10	Link-Down Interrupt Enable	1 = Enable link-down interrupt 0 = Disable link-down interrupt	RW	0
1B.9	Remote Fault Interrupt Enable	1 = Enable remote fault interrupt 0 = Disable remote fault interrupt	RW	0
1B.8	Link-Up Interrupt Enable	1 = Enable link-up interrupt 0 = Disable link-up interrupt	RW	0
1B.7	Jabber Interrupt	1 = Jabber occurred 0 = Jabber did not occur	RO/SC	0
1B.6	Receive Error Interrupt	1 = Receive error occurred 0 = Receive error did not occur	RO/SC	0
1B.5	Page Receive Interrupt	1 = Page receive occurred 0 = Page receive did not occur	RO/SC	0
1B.4	Parallel Detect Fault Interrupt	1 = Parallel detect fault occurred 0 = Parallel detect fault did not occur	RO/SC	0
1B.3	Link Partner Acknowledge Interrupt	1 = Link partner acknowledge occurred 0 = Link partner acknowledge did not occur	RO/SC	0
1B.2	Link-Down Interrupt	1 = Link-down occurred 0 = Link-down did not occur	RO/SC	0
1B.1	Remote Fault Interrupt	1 = Remote fault occurred 0 = Remote fault did not occur	RO/SC	0

TABLE 4-2: REGISTER DESCRIPTIONS (CONTINUED)

Address	Name	Description	Mode Note 4-1	Default
1B.0	Link-Up Interrupt	1 = Link-up occurred 0 = Link-up did not occur	RO/SC	0
Register 1Dh – LinkMD Control/Status				
1D.15	Cable Diagnostic Test Enable	1 = Enable cable diagnostic test. After test has completed, this bit is self-cleared. 0 = Indicates cable diagnostic test (if enabled) has completed and the status information is valid for read.	RW/SC	0
1D.14:13	Cable Diagnostic Test Result	[00] = Normal condition [01] = Open condition has been detected in cable [10] = Short condition has been detected in cable [11] = Cable diagnostic test has failed	RO	00
1D.12	Short Cable Indicator	1 = Short cable (<10 meter) has been detected by LinkMD	RO	0
1D.11:9	Reserved	Reserved	RW	000
1D.8:0	Cable Fault Counter	Distance to fault	RO	0_0000_0000
Register 1Eh – PHY Control 1				
1E.15:10	Reserved	Reserved	RO	0000_00
1E.9	Enable Pause (Flow Control)	1 = Flow control capable 0 = No flow control capability	RO	0
1E.8	Link Status	1 = Link is up 0 = Link is down	RO	0
1E.7	Polarity Status	1 = Polarity is reversed 0 = Polarity is not reversed	RO	—
1E.6	Reserved	Reserved	RO	0
1E.5	MDI/MDI-X State	1 = MDI-X 0 = MDI	RO	—
1E.4	Energy Detect	1 = Signal present on receive differential pair 0 = No signal detected on receive differential pair	RO	0
1E.3	PHY Isolate	1 = PHY in isolate mode 0 = PHY in normal operation	RW	0
1E.2:0	Operation Mode Indication	[000] = Still in auto-negotiation [001] = 10BASE-T half-duplex [010] = 100BASE-TX half-duplex [011] = Reserved [100] = Reserved [101] = 10BASE-T full-duplex [110] = 100BASE-TX full-duplex [111] = Reserved	RO	000
Register 1Fh – PHY Control 2				
1F.15	HP_MDIX	1 = HP Auto MDI/MDI-X mode 0 = Microchip Auto MDI/MDI-X mode	RW	1

KSZ8081MLX

TABLE 4-2: REGISTER DESCRIPTIONS (CONTINUED)

Address	Name	Description	Mode Note 4-1	Default
1F.14	MDI/MDI-X Select	When Auto MDI/MDI-X is disabled, 1 = MDI-X mode Transmit on RXP, RXM (Pins 10, 9) and Receive on TXP, TXM (Pins 12, 11) 0 = MDI mode Transmit on TXP, TXM (Pins 12, 11) and Receive on RXP, RXM (Pins 10, 9)	RW	0
1F.13	Pair Swap Disable	1 = Disable Auto MDI/MDI-X 0 = Enable Auto MDI/MDI-X	RW	0
1F.12	Reserved	Reserved	RW	0
1F.11	Force Link	1 = Force link pass 0 = Normal link operation This bit bypasses the control logic and allows the transmitter to send a pattern even if there is no link.	RW	0
1F.10	Power Saving	1 = Enable power saving 0 = Disable power saving	RW	0
1F.9	Interrupt Level	1 = Interrupt pin active high 0 = Interrupt pin active low	RW	0
1F.8	Enable Jabber	1 = Enable jabber counter 0 = Disable jabber counter	RW	1
1F.7:6	Reserved	Reserved	RW	0
1F.5:4	LED Mode	[00] = LED1: Speed LED0: Link/Activity [01] = LED1: Activity LED0: Link [10], [11] = Reserved	RW	00
1F.3	Disable Transmitter	1 = Disable transmitter 0 = Enable transmitter	RW	0
1F.2	Remote Loopback	1 = Remote (analog) loopback is enabled 0 = Normal mode	RW	0
1F.1	Enable SQE Test	1 = Enable SQE test 0 = Disable SQE test	RW	0
1F.0	Disable Data Scrambling	1 = Disable scrambler 0 = Enable scrambler	RW	0

Note 4-1 RW = Read/Write; RO = Read Only; SC = Self-Cleared; LH = Latch High; LL = Latch Low.

5.0 OPERATIONAL CHARACTERISTICS

5.1 Absolute Maximum Ratings*

Supply Voltage (V_{IN})	
($V_{DD_1.2}$).....	-0.5V to +1.8V
($V_{DDIO}, V_{DDA_3.3}$).....	-0.5V to +5.0V
Input Voltage (all inputs).....	-0.5V to +5.0V
Output Voltage (all outputs).....	-0.5V to +5.0V
Lead Temperature (soldering, 10s).....	+260°C
Storage Temperature (T_S).....	-55°C to +150°C

*Exceeding the absolute maximum rating may damage the device. Stresses greater than the absolute maximum rating may cause permanent damage to the device. Operation of the device at these or any other conditions above those specified in the operating sections of this specification is not implied. Maximum conditions for extended periods may affect reliability.

5.2 Operating Ratings**

Supply Voltage	
($V_{DDIO_3.3}, V_{DDA_3.3}$).....	+3.135V to +3.465V
($V_{DDIO_2.5}$).....	+2.375V to +2.625V
($V_{DDIO_1.8}$).....	+1.710V to +1.890V
Ambient Temperature	
(T_A Commercial).....	0°C to +70°C
(T_A Industrial).....	-40°C to +85°C
Maximum Junction Temperature (T_J max.).....	+125°C
Thermal Resistance (Θ_{JA}).....	+76°C/W
Thermal Resistance (Θ_{JC}).....	+15°C/W

**The device is not guaranteed to function outside its operating ratings.

Note: Do not drive input signals without power supplied to the device.

KSZ8081MLX

6.0 ELECTRICAL CHARACTERISTICS

$T_A = 25^\circ\text{C}$. Specification is for packaged product only.

TABLE 6-1: ELECTRICAL CHARACTERISTICS

Parameters	Symbol	Min.	Typ.	Max.	Units	Note
Supply Current ($V_{DDIO}, V_{DDA_3.3} = 3.3\text{V}$), Note 6-1						
10BASE-T	$I_{DD1_3.3\text{V}}$	—	41	—	mA	Full-duplex traffic @ 100% utilization
100BASE-TX	$I_{DD2_3.3\text{V}}$	—	47	—	mA	Full-duplex traffic @ 100% utilization
EDPD Mode	$I_{DD3_3.3\text{V}}$	—	20	—	mA	Ethernet cable disconnected (Reg. 18h.11 = 0)
Power-Down Mode	$I_{DD4_3.3\text{V}}$	—	4	—	mA	Software power-down (Reg. 0h.11 = 1)
CMOS Level Inputs						
Output High Voltage	V_{OH}	2.4	—	—	V	$V_{DDIO} = 3.3\text{V}$
		2.0	—	—	V	$V_{DDIO} = 2.5\text{V}$
		1.5	—	—	V	$V_{DDIO} = 1.8\text{V}$
Output Low Voltage	V_{OL}	—	—	0.4	V	$V_{DDIO} = 3.3\text{V}$
		—	—	0.4	V	$V_{DDIO} = 2.5\text{V}$
		—	—	0.3	V	$V_{DDIO} = 1.8\text{V}$
Output Tri-State Leakage	$ I_{OZ} $	—	—	10	μA	—
LED Output						
Output Drive Current	I_{LED}	—	8	—	mA	Each LED pin (LED0, LED1)
All Pull-Up/Pull-Down Pins (including Strapping Pins)						
Internal Pull-Up Resistance	pu	30	45	73	k Ω	$V_{DDIO} = 3.3\text{V}$
		39	61	102	k Ω	$V_{DDIO} = 2.5\text{V}$
		48	99	178	k Ω	$V_{DDIO} = 1.8\text{V}$
Internal Pull-Down Resistance	pd	26	43	79	k Ω	$V_{DDIO} = 3.3\text{V}$
		34	59	113	k Ω	$V_{DDIO} = 2.5\text{V}$
		53	99	200	k Ω	$V_{DDIO} = 1.8\text{V}$
100BASE-TX Transmit (measured differentially after 1:1 transformer)						
Peak Differential Output Voltage	V_O	0.95	—	1.05	V	100 Ω termination across differential output
Output Voltage Imbalance	V_{IMB}	—	—	2	%	100 Ω termination across differential output
Rise/Fall Time	t_r/t_f	3	—	5	ns	—
Rise/Fall Time Imbalance	—	0	—	0.5	ns	—
Duty Cycle Distortion	—	—	—	± 0.25	ns	—
Overshoot	—	—	—	5	%	—
Output Jitter	—	—	0.7	—	ns	Peak-to-peak
10BASE-T Transmit (measured differentially after 1:1 transformer)						
Peak Differential Output Voltage	V_P	2.2	—	2.8	V	100 Ω termination across differential output
Jitter Added	—	—	—	3.5	ns	Peak-to-peak
Rise/Fall Time	t_r/t_f	—	25	—	ns	—
10BASE-T Receive						
Squelch Threshold	V_{SQ}	—	400	—	mV	5 MHz square wave
Transmitter - Drive Setting						
Reference Voltage of I_{SET}	V_{SET}	—	0.65	—	V	$R(I_{SET}) = 6.49\text{ k}\Omega$

TABLE 6-1: ELECTRICAL CHARACTERISTICS (CONTINUED)

Parameters	Symbol	Min.	Typ.	Max.	Units	Note
100 Mbps Mode - Industrial Applications Parameters						
Clock Phase Delay – XI Input to MII TXC Output	—	15	20	25	ns	XI (25 MHz clock input) to MII TXC (25 MHz clock output) delay, referenced to rising edges of both clocks.
Link Loss Reaction (Indication) Time	t_{lr}	—	4.4	—	μ s	Link loss detected at receive differential inputs to PHY signal indication time for each of the following: 1. For LED mode 01, Link LED output changes from low (link-up) to high (link-down). 2. INTRP pin asserts for link-down status change.

Note 6-1 Current consumption is for the single 3.3V supply KSZ8081MLX device only, and includes the transmit driver current and the 1.2V supply voltage ($V_{DD,1.2}$) that are supplied by the KSZ8081MLX.

KSZ8081MLX

7.0 TIMING DIAGRAMS

7.1 MII SQE Timing (10BASE-T)

FIGURE 7-1: MII SQE TIMING (10BASE-T)

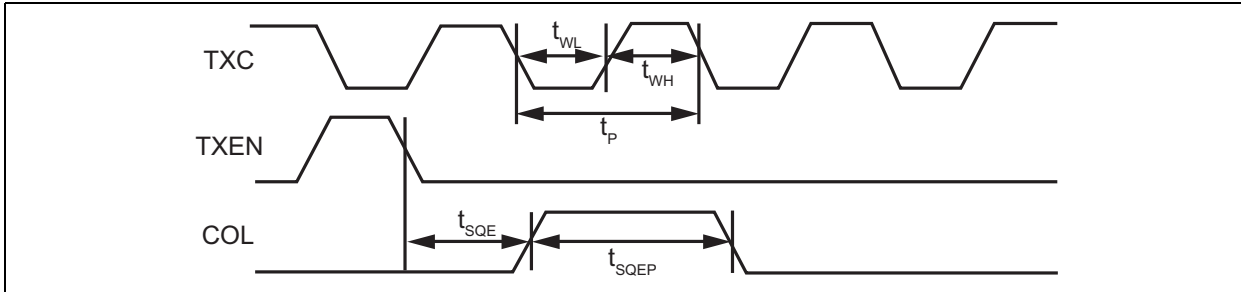

TABLE 7-1: MII SQE TIMING (10BASE-T) PARAMETERS

Parameter	Description	Min.	Typ.	Max.	Units
t_P	TXC period	—	400	—	ns
t_{WL}	TXC pulse width low	—	200	—	ns
t_{WH}	TXC pulse width high	—	200	—	ns
t_{SQE}	COL (SQE) delay after TXEN de-asserted	—	2.2	—	μ s
t_{SQEP}	COL (SQE) pulse duration	—	1.0	—	μ s

7.2 MII Transmit Timing (10BASE-T)

FIGURE 7-2: MII TRANSMIT TIMING (10BASE-T)

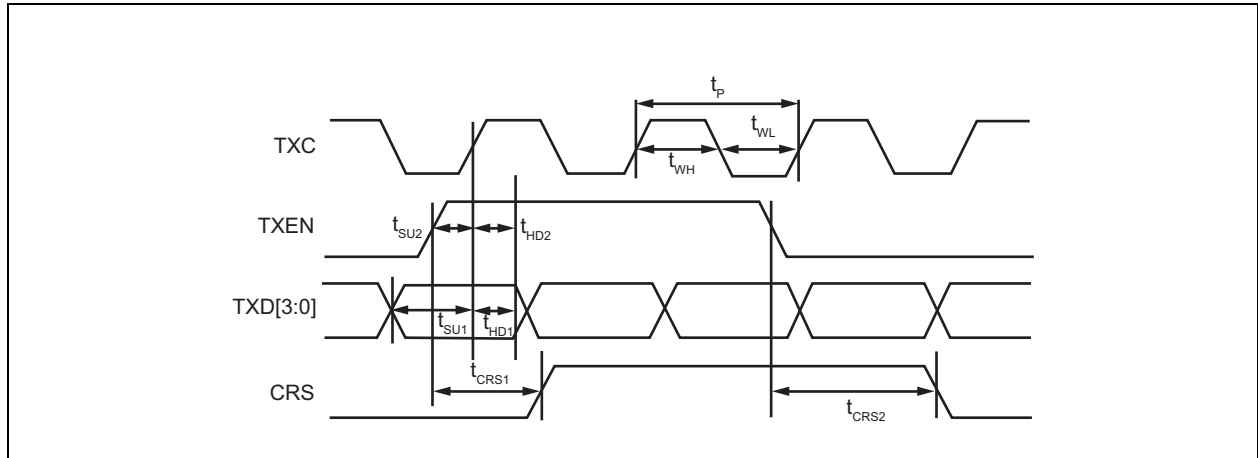

TABLE 7-2: MII TRANSMIT TIMING (10BASE-T) PARAMETERS

Parameter	Description	Min.	Typ.	Max.	Units
t_p	TXC period	—	400	—	ns
t_{WL}	TXC pulse width low	—	200	—	ns
t_{WH}	TXC pulse width high	—	200	—	ns
t_{SU1}	TXD[3:0] setup to rising edge of TXC	120	—	—	ns
t_{SU2}	TXEN setup to rising edge of TXC	120	—	—	ns
t_{HD1}	TXD[3:0] hold from rising edge of TXC	0	—	—	ns
t_{HD2}	TXEN hold from rising edge of TXC	0	—	—	ns
t_{CRS1}	TXEN high to CRS asserted latency	—	600	—	ns
t_{CRS2}	TXEN low to CRS de-asserted latency	—	1.0	—	μ s

KSZ8081MLX

7.3 MII Receive Timing (10BASE-T)

FIGURE 7-3: MII RECEIVE TIMING (10BASE-T)

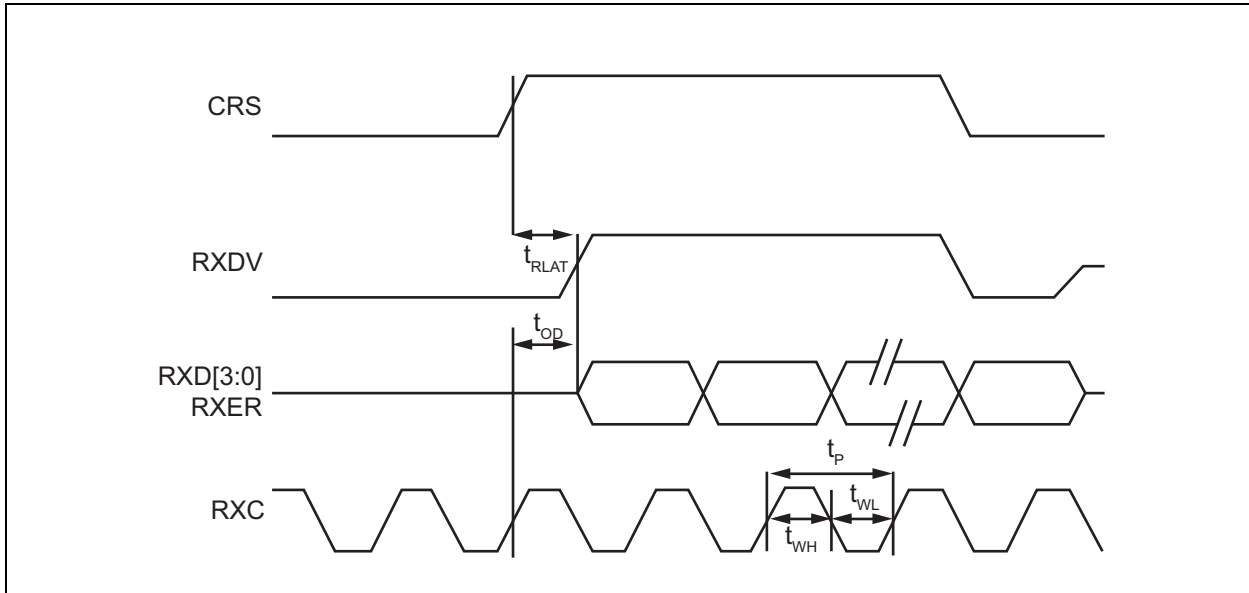

TABLE 7-3: MII RECEIVE TIMING (10BASE-T) PARAMETERS

Parameter	Description	Min.	Typ.	Max.	Units
t_p	RXC period	—	400	—	ns
t_{WL}	RXC pulse width low	—	200	—	ns
t_{WH}	RXC pulse width high	—	200	—	ns
t_{OD}	(RXDV, RXD[3:0], RXER) output delay from rising edge of RXC	—	205	—	ns
t_{RLAT}	CRS to (RXDV, RXD[3:0]) latency	—	7.2	—	μ s

7.4 MII Transmit Timing (100BASE-TX)

FIGURE 7-4: MII TRANSMIT TIMING (100BASE-TX)

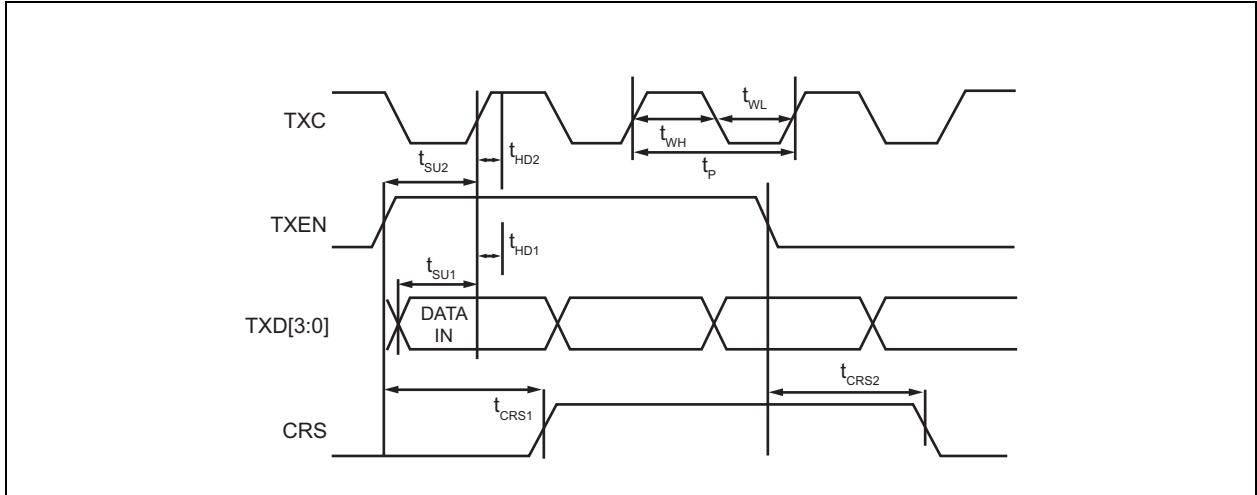

TABLE 7-4: MII TRANSMIT TIMING (100BASE-TX) PARAMETERS

Parameter	Description	Min.	Typ.	Max.	Units
t_p	TXC period	—	40	—	ns
t_{WL}	TXC pulse width low	—	20	—	ns
t_{WH}	TXC pulse width high	—	20	—	ns
t_{SU1}	TXD[3:0] setup to rising edge of TXC	10	—	—	ns
t_{SU2}	TXEN setup to rising edge of TXC	10	—	—	ns
t_{HD1}	TXD[3:0] hold from rising edge of TXC	0	—	—	ns
t_{HD2}	TXEN hold from rising edge of TXC	0	—	—	ns
t_{CRS1}	TXEN high to CRS asserted latency	—	72	—	ns
t_{CRS2}	TXEN low to CRS de-asserted latency	—	72	—	ns

KSZ8081MLX

7.5 MII Receive Timing (100BASE-TX)

FIGURE 7-5: MII RECEIVE TIMING (100BASE-TX)

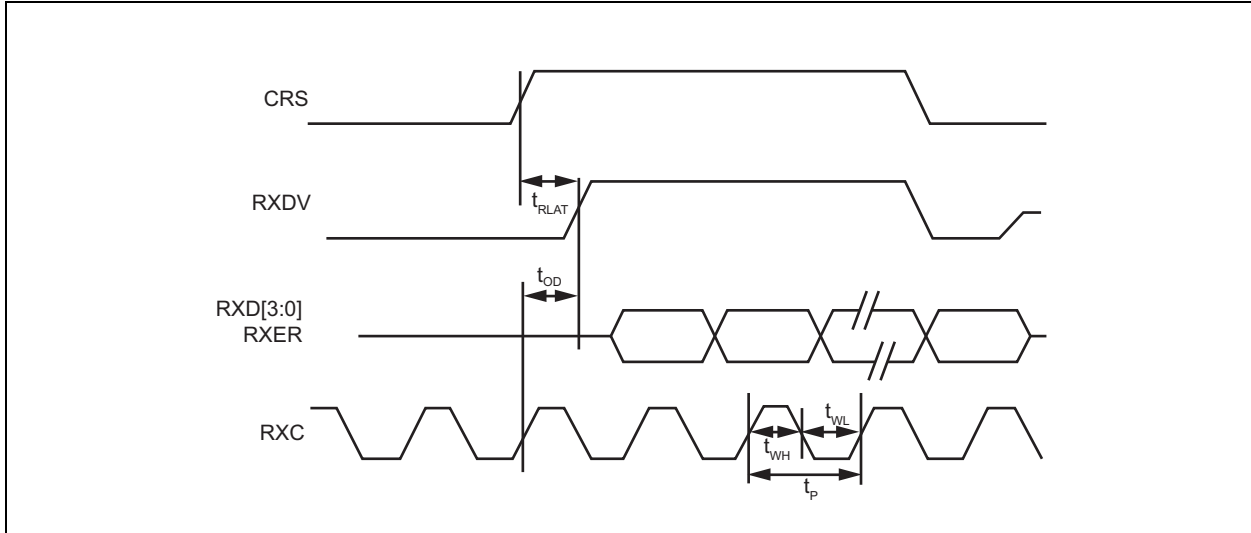

TABLE 7-5: MII RECEIVE TIMING (10BASE-T) PARAMETERS

Parameter	Description	Min.	Typ.	Max.	Units
t_p	RXC period	—	40	—	ns
t_{WL}	RXC pulse width low	—	20	—	ns
t_{WH}	RXC pulse width high	—	20	—	ns
t_{OD}	(RXDV, RXD[3:0], RXER) output delay from rising edge of RXC	16	21	25	ns
t_{RLAT}	CRS to (RXDV, RXD[3:0]) latency	—	170	—	ns

7.6 Auto-Negotiation Timing

FIGURE 7-6: AUTO-NEGOTIATION FAST LINK PULSE (FLP) TIMING

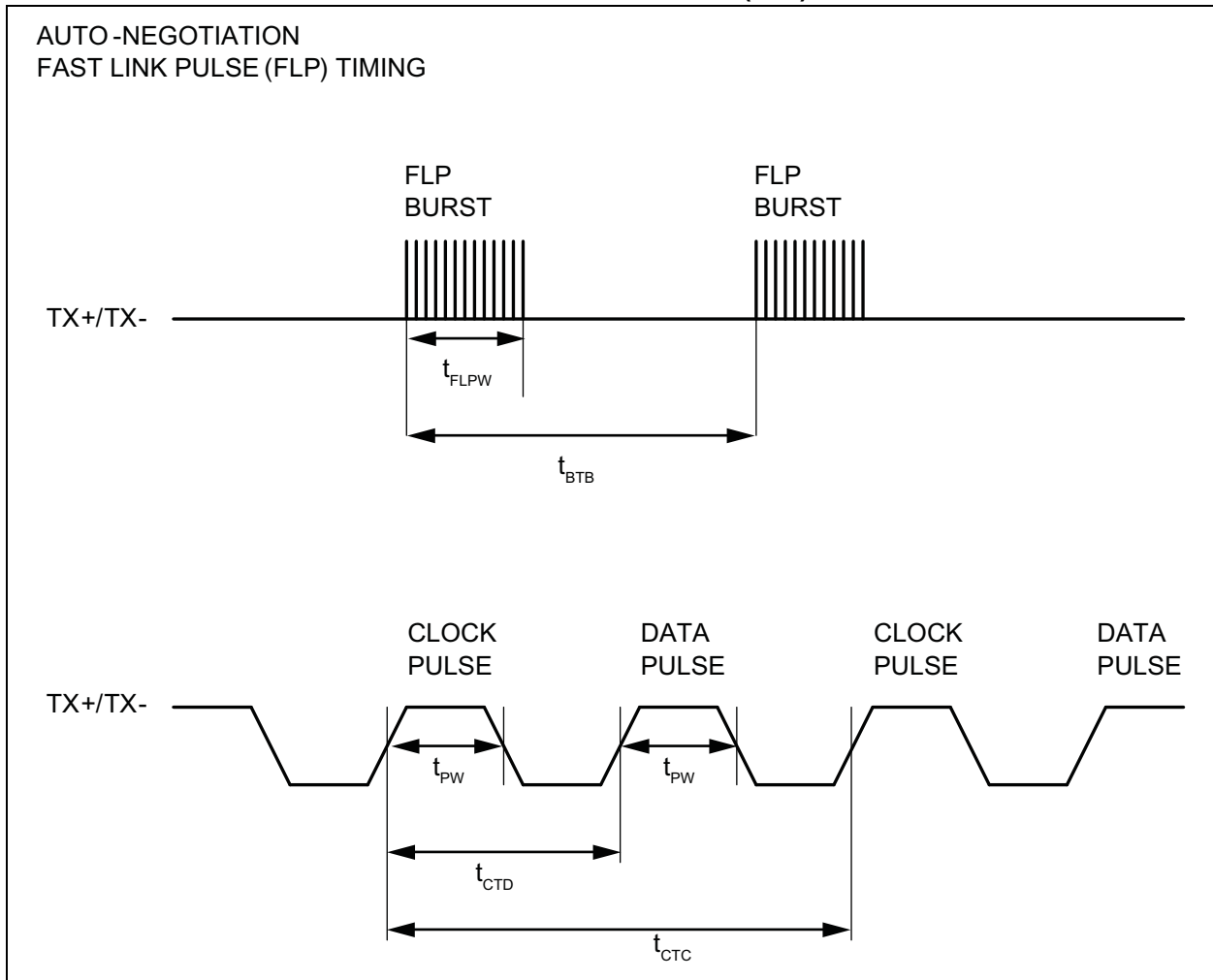

TABLE 7-6: AUTO-NEGOTIATION FAST LINK PULSE TIMING PARAMETERS

Parameter	Description	Min.	Typ.	Max.	Units
t_{BTB}	FLP burst to FLP burst	8	16	24	ms
t_{FLPW}	FLP burst width	—	2	—	ms
t_{PW}	Clock/Data pulse width	—	100	—	ns
t_{CTD}	Clock pulse to data pulse	55.5	64	69.5	μ s
t_{CTC}	Clock pulse to clock pulse	111	128	139	μ s
—	Number of clock/data pulses per FLP burst	17	—	33	—

KSZ8081MLX

7.7 MDC/MDIO Timing

FIGURE 7-7: MDC/MDIO TIMING

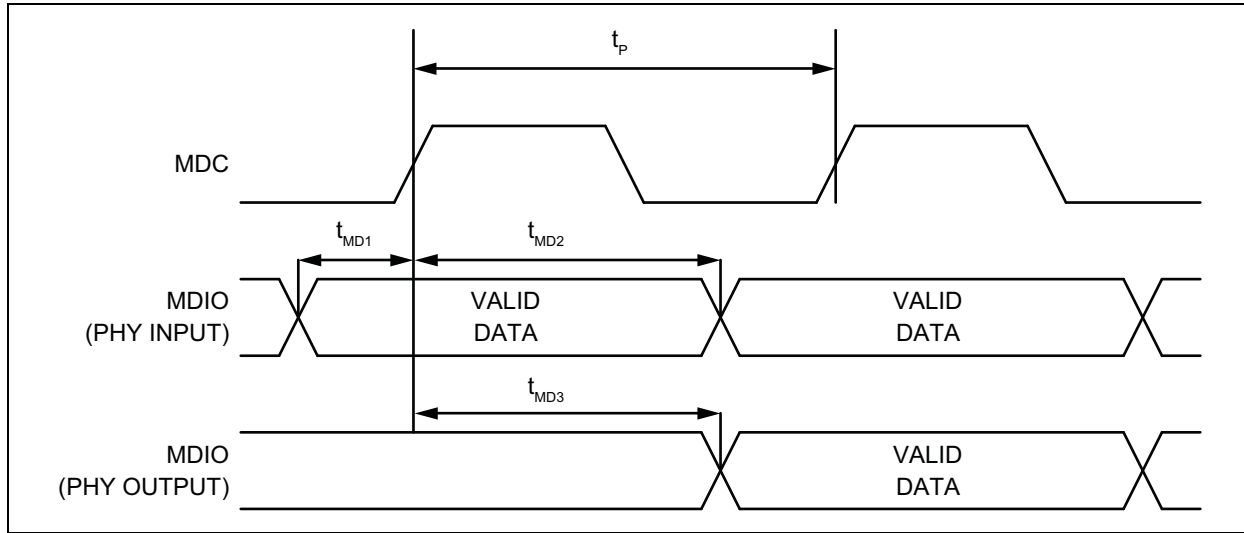

TABLE 7-7: MDC/MDIO TIMING PARAMETERS

Parameter	Description	Min.	Typ.	Max.	Units
f_c	MDC Clock Frequency	—	2.5	10	MHz
t_p	MDC period	—	400	—	ns
t_{MD1}	MDIO (PHY input) setup to rising edge of MDC	10	—	—	ns
t_{MD2}	MDIO (PHY input) hold from rising edge of MDC	4	—	—	ns
t_{MD3}	MDIO (PHY output) delay from rising edge of MDC	5	222	—	ns

7.8 Power-Up/Reset Timing

The KSZ8081MLX reset timing requirement is summarized in Figure 7-8 and Table 7-8.

FIGURE 7-8: POWER-UP/RESET TIMING

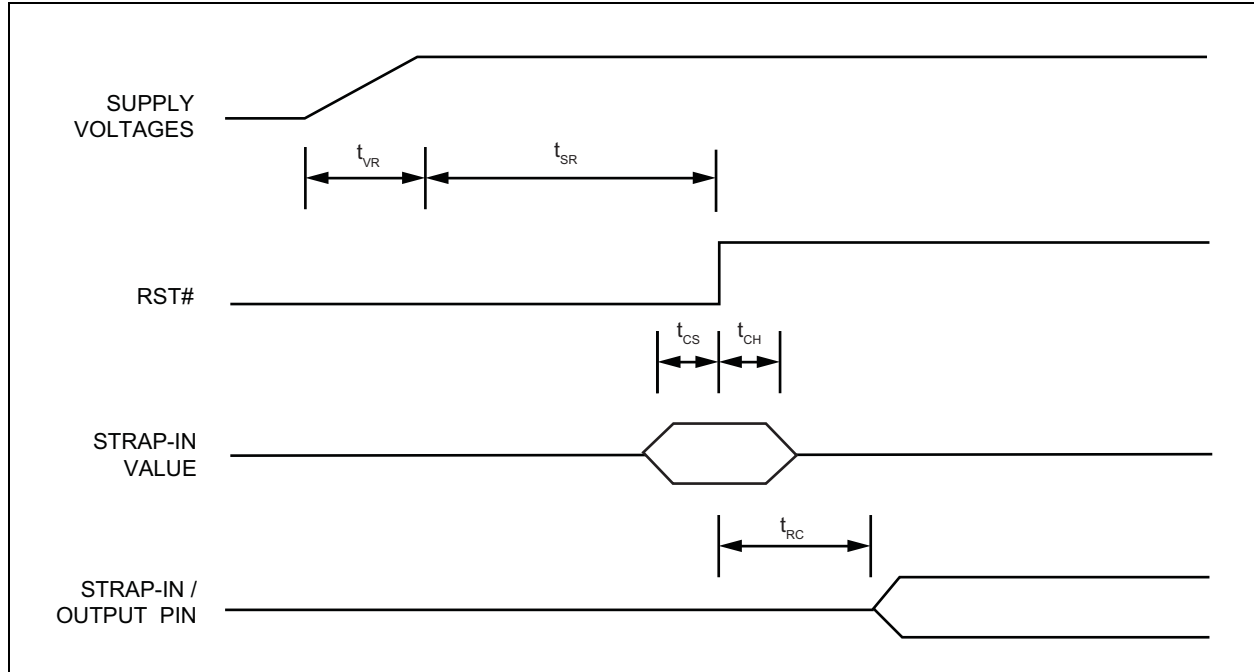

TABLE 7-8: POWER-UP/RESET TIMING PARAMETERS

Parameter	Description	Min.	Typ.	Max.	Units
t_{VR}	Supply voltage (V_{DDIO} , $V_{DDA_3.3}$) rise time	300	—	—	μs
t_{SR}	Stable supply voltage (V_{DDIO} , $V_{DDA_3.3}$) to reset high	10	—	—	ms
t_{CS}	Configuration setup time	5	—	—	ns
t_{CH}	Configuration hold time	5	—	—	ns
t_{RC}	Reset to strap-in pin output	6	—	—	ns

The supply voltage (V_{DDIO} and $V_{DDA_3.3}$) power-up waveform should be monotonic. The 300 μs minimum rise time is from 10% to 90%.

For warm reset, the reset (RST#) pin should be asserted low for a minimum of 500 μs . The strap-in pin values are read and updated at the de-assertion of reset.

After the de-assertion of reset, wait a minimum of 100 μs before starting programming on the MIIM (MDC/MDIO) interface.

KSZ8081MLX

8.0 RESET CIRCUIT

Figure 8-1 shows a reset circuit recommended for powering up the KSZ8081MLX if reset is triggered by the power supply.

FIGURE 8-1: RECOMMENDED RESET CIRCUIT

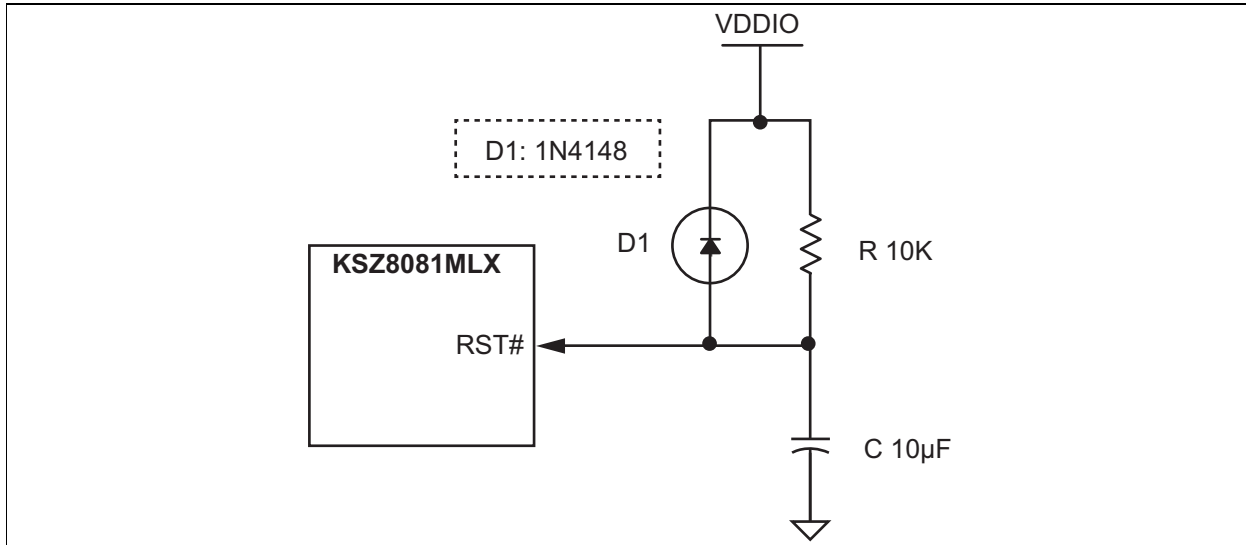
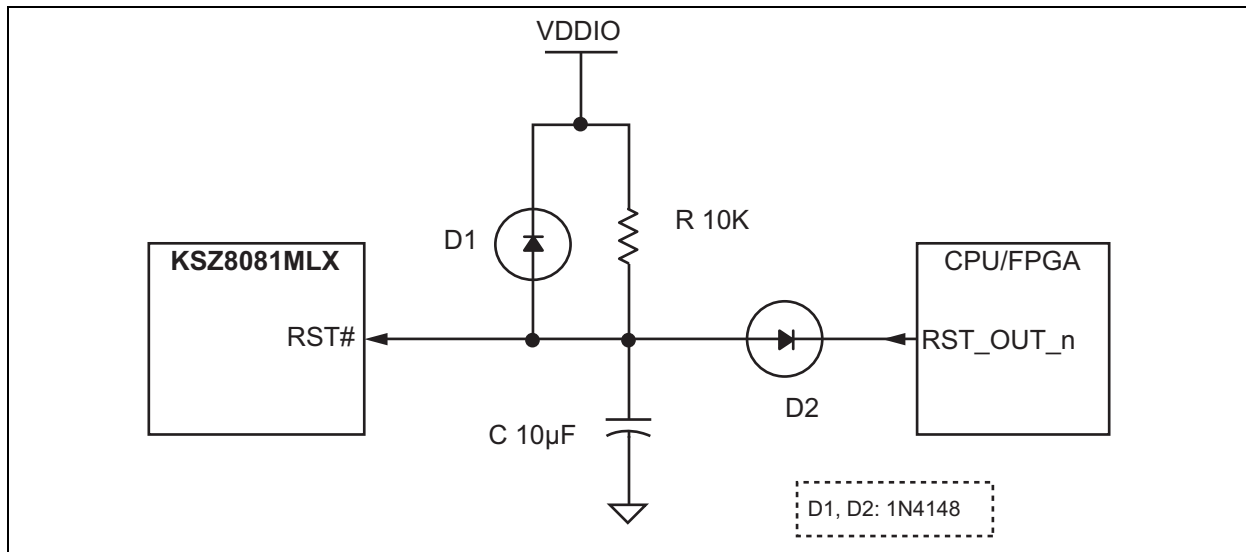

Figure 8-2 shows a reset circuit recommended for applications where reset is driven by another device (for example, the CPU or an FPGA). The reset out RST_OUT_n from CPU/FPGA provides the warm reset after power up reset. D2 is used if using different V_{DDIO} between the switch and CPU/FPGA, otherwise, the different V_{DDIO} will fight each other. If different V_{DDIO} have to use in a special case, a low V_F (<0.3V) diode is required (for example, Vishay's BAT54, MSS1P2L and so on), or a level shifter device can be used too. If Ethernet device and CPU/FPGA use same V_{DDIO} voltage, D2 can be removed to connect both devices directly. Usually, Ethernet device and CPU/FPGA should use same V_{DDIO} voltage.

FIGURE 8-2: RECOMMENDED RESET CIRCUIT FOR CPU/FPGA RESET OUTPUT



9.0 REFERENCE CIRCUITS — LED STRAP-IN PINS

The pull-up, float, and pull-down reference circuits for the LED0/NWAYEN strapping pin are shown in Figure 9-1 for 3.3V and 2.5V V_{DDIO} .

FIGURE 9-1: REFERENCE CIRCUITS FOR LED STRAPPING PINS

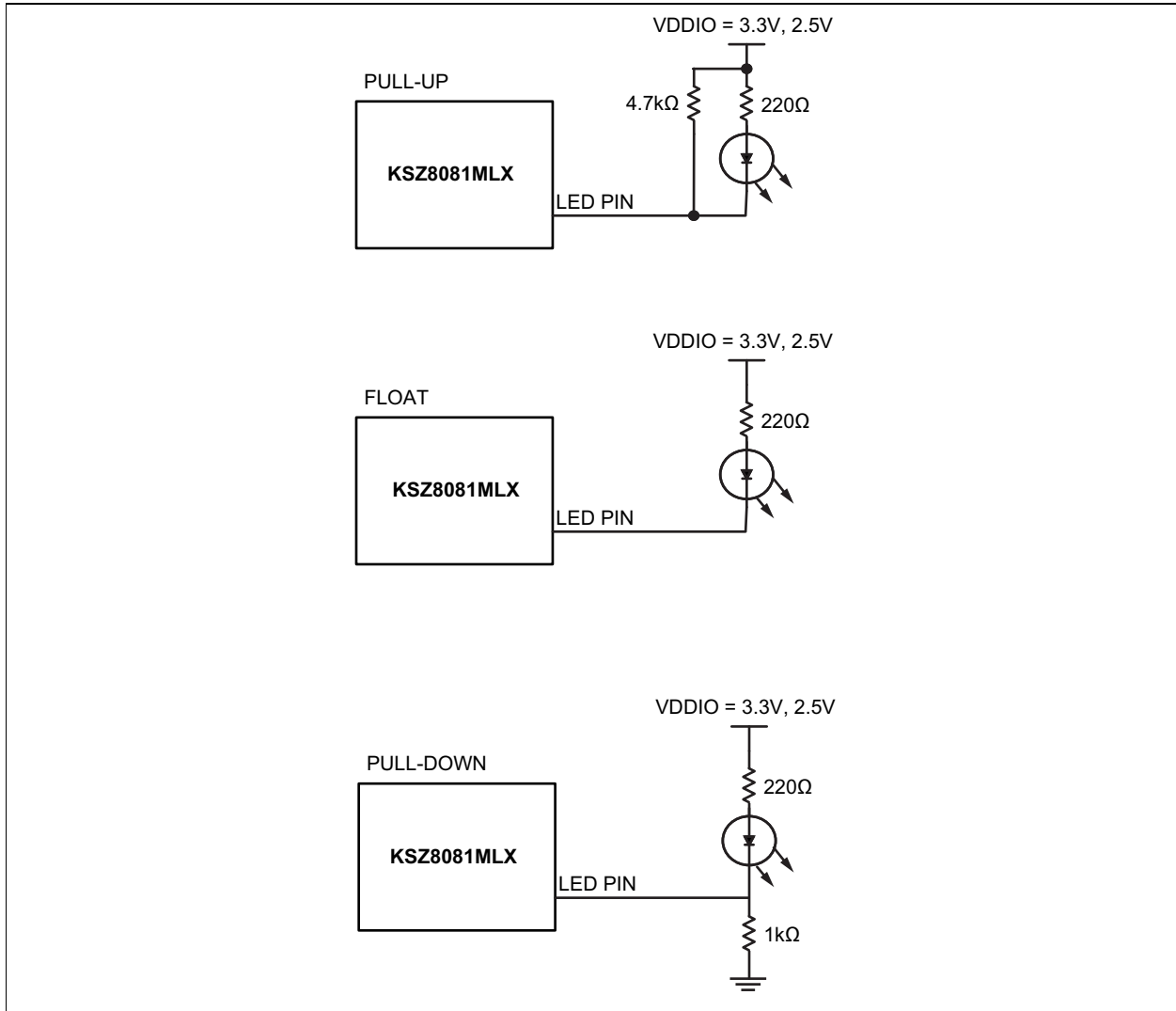

For 1.8V V_{DDIO} , LED indication support is not recommended due to the low voltage. Without the LED indicator, the SPEED and NWAYEN strap-in pins are functional with a 4.7 k Ω pull-up to 1.8V V_{DDIO} or float for a value of '1', and with a 1.0 k Ω pull-down to ground for a value of '0'.

If using RJ45 jacks with integrated LEDs and 1.8V V_{DDIO} , a level shifting is required from LED 3.3V to 1.8V. For example, use a bipolar transistor or a level shift device.

KSZ8081MLX

10.0 REFERENCE CLOCK - CONNECTION AND SELECTION

A crystal or external clock source, such as an oscillator, is used to provide the reference clock for the KSZ8081MLX. For the KSZ8081MLX in all operating modes, the reference clock is 25 MHz. The reference clock connections to XI (Pin 15) and XO (Pin 14), and the reference clock selection criteria, are provided in [Figure 10-1](#) and [Table 10-1](#).

FIGURE 10-1: 25 MHz CRYSTAL/OSCILLATOR REFERENCE CLOCK CONNECTION

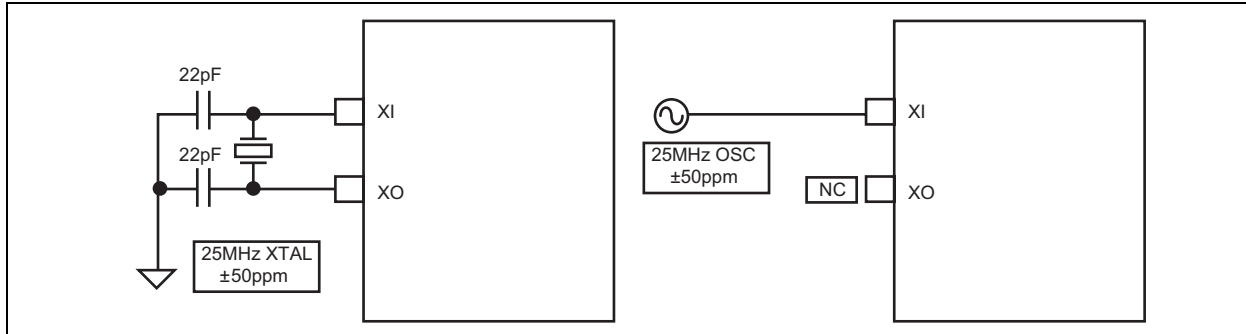

TABLE 10-1: 25 MHz CRYSTAL/REFERENCE CLOCK SELECTION CRITERIA

Characteristics	Value
Frequency	25 MHz
Frequency Tolerance (max.); Note 10-1	±50 ppm
Crystal Series Resistance (typ.)	40Ω
Crystal Load Capacitance (typ.)	16 pF

Note 10-1 ±60 ppm for overtemperature crystal.

11.0 MAGNETIC - CONNECTION AND SELECTION

A 1:1 isolation transformer is required at the line interface. Use one with integrated common-mode chokes for designs exceeding FCC requirements.

The KSZ8081MLX design incorporates voltage-mode transmit drivers and on-chip terminations.

With the voltage-mode implementation, the transmit drivers supply the common-mode voltages to the two differential pairs. Therefore, the two transformer center tap pins on the KSZ8081MLX side should not be connected to any power supply source on the board; instead, the center tap pins should be separated from one another and connected through separate 0.1 μF common-mode capacitors to ground. Separation is required because the common-mode voltage is different between transmitting and receiving differential pairs.

Figure 11-1 shows the typical magnetic interface circuit for the KSZ8081MLX.

FIGURE 11-1: TYPICAL MAGNETIC INTERFACE CIRCUIT

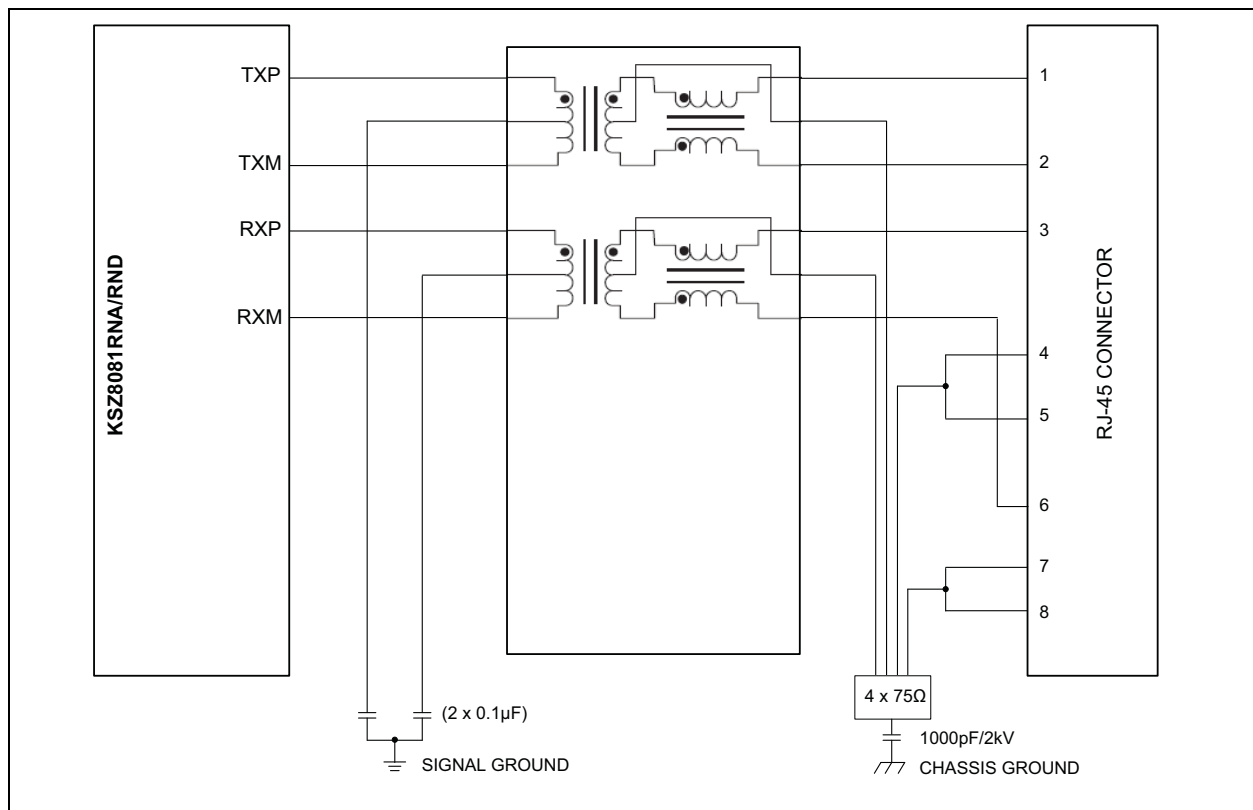

Table 11-1 lists recommended magnetic characteristics.

TABLE 11-1: MAGNETICS SELECTION CRITERIA

Parameter	Value	Test Conditions
Turns Ratio	1 CT : 1 CT	—
Open-Circuit Inductance (min.)	350 μH	100 mV, 100 kHz, 8 mA
Insertion Loss (max.)	-1.1 dB	100 kHz to 100 MHz
HIPOT (min.)	1500 V_{RMS}	—

Table 11-2 is a list of compatible single-port magnetics with separated transformer center tap pins on the PHY chip side that can be used with the KSZ8081MLX.

KSZ8081MLX

TABLE 11-2: COMPATIBLE SINGLE-PORT 10/100 MAGNETICS

Manufacturer	Part Number	Temperature Range	Magnetic + RJ-45
Bel Fuse	S558-5999-U7	0°C to 70°C	No
Bel Fuse	SI-46001-F	0°C to 70°C	Yes
Bel Fuse	SI-50170-F	0°C to 70°C	Yes
Delta	LF8505	0°C to 70°C	No
HALO	HFJ11-2450E	0°C to 70°C	Yes
HALO	TG110-E055N5	-40°C to 85°C	No
LANKom	LF-H41S-1	0°C to 70°C	No
Pulse	H1102	0°C to 70°C	No
Pulse	H1260	0°C to 70°C	No
Pulse	HX1188	-40°C to 85°C	No
Pulse	J00-0014	0°C to 70°C	Yes
Pulse	JX0011D21NL	-40°C to 85°C	Yes
TDK	TLA-6T718A	0°C to 70°C	Yes
Transpower	HB726	0°C to 70°C	No
Würth/Midcom	000-7090-37R-LF1	-40°C to 85°C	No

12.0 PACKAGE OUTLINE

FIGURE 12-1: 48-LEAD LQFP 7 MM X 7 MM PACKAGE

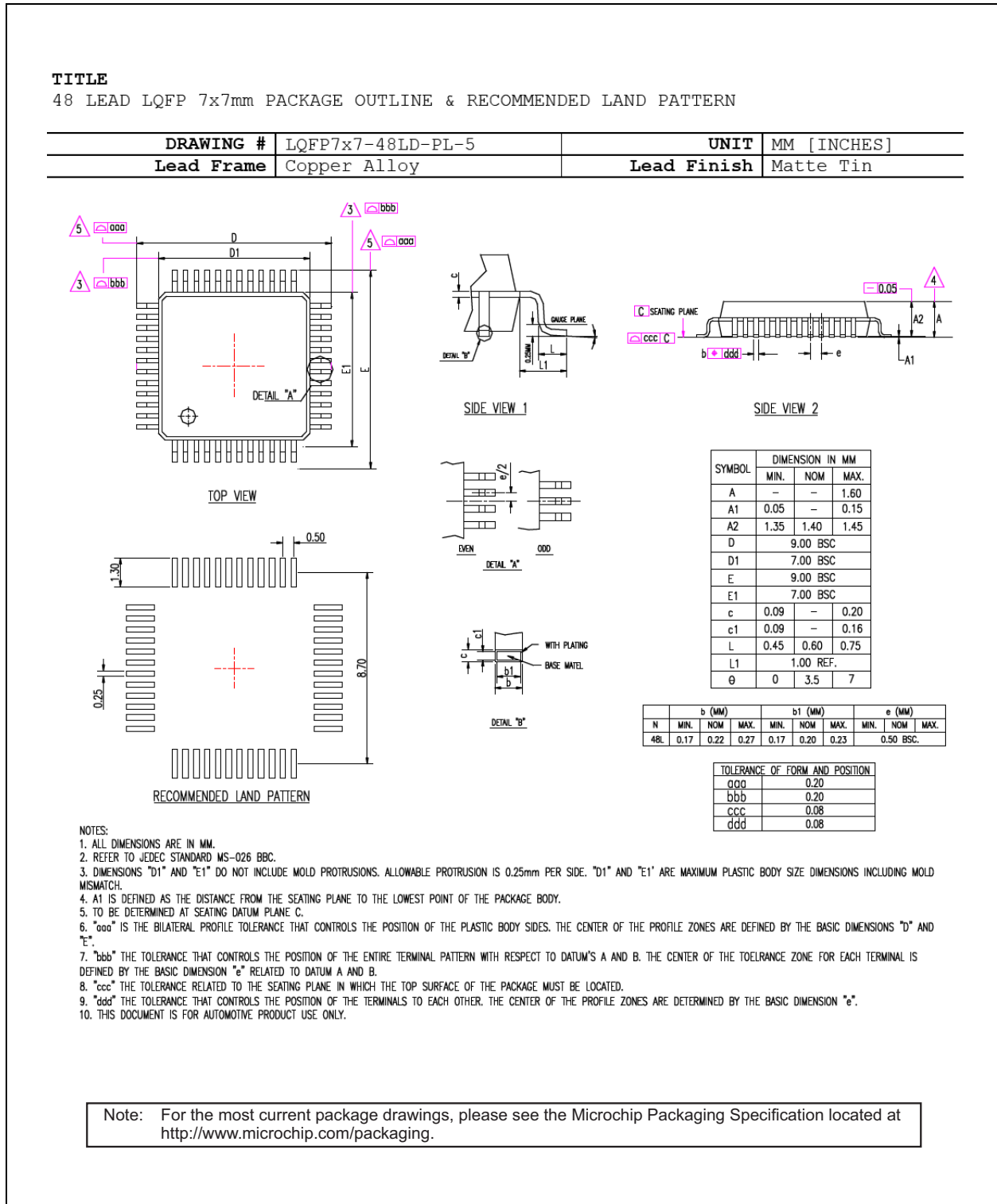

KSZ8081MLX

APPENDIX A: DATA SHEET REVISION HISTORY

TABLE A-1: REVISION HISTORY

Revision	Section/Figure/Entry	Correction
DS00002264A (08-30-16)	—	Converted Micrel data sheet KSZ8081MLX to Microchip DS00002264A. Minor text changes throughout.

THE MICROCHIP WEB SITE

Microchip provides online support via our WWW site at www.microchip.com. This web site is used as a means to make files and information easily available to customers. Accessible by using your favorite Internet browser, the web site contains the following information:

- **Product Support** – Data sheets and errata, application notes and sample programs, design resources, user's guides and hardware support documents, latest software releases and archived software
- **General Technical Support** – Frequently Asked Questions (FAQ), technical support requests, online discussion groups, Microchip consultant program member listing
- **Business of Microchip** – Product selector and ordering guides, latest Microchip press releases, listing of seminars and events, listings of Microchip sales offices, distributors and factory representatives

CUSTOMER CHANGE NOTIFICATION SERVICE

Microchip's customer notification service helps keep customers current on Microchip products. Subscribers will receive e-mail notification whenever there are changes, updates, revisions or errata related to a specified product family or development tool of interest.

To register, access the Microchip web site at www.microchip.com. Under "Support", click on "Customer Change Notification" and follow the registration instructions.

CUSTOMER SUPPORT

Users of Microchip products can receive assistance through several channels:

- Distributor or Representative
- Local Sales Office
- Field Application Engineer (FAE)
- Technical Support

Customers should contact their distributor, representative or field application engineer (FAE) for support. Local sales offices are also available to help customers. A listing of sales offices and locations is included in the back of this document.

Technical support is available through the web site at: <http://microchip.com/support>

KSZ8081MLX

PRODUCT IDENTIFICATION SYSTEM

To order or obtain information, e.g., on pricing or delivery, refer to the factory or the listed sales office.

<u>PART NO.</u>	X	X	X	XX	—	XX
Device	Interface	Package	Special Attribute	Temperature		Media Type
Device: KSZ8081 Interface: M = MII Package: L = 48-pin LQFP Special Attribute: X = None Temperature: CA = 0°C to +70°C (Commercial) IA = -40°C to +85°C (Industrial) Media Type: blank = Tray TR = Tape & Reel	Examples: a) KSZ8081MLXCA MII Interface 48-pin LQFP No Special Attribute Commercial Temperature Tray b) KSZ8081MLXIA MII Interface 48-pin QFN No Special Attribute Industrial Temperature Tray c) KSZ8081MLXCA-TR MII Interface 48-pin QFN No Special Attribute Commercial Temperature Tape & Reel d) KSZ8081MLXIA-TR MII Interface 48-pin QFN No Special Attribute Industrial Temperature Tape & Reel					

Note the following details of the code protection feature on Microchip devices:

- Microchip products meet the specification contained in their particular Microchip Data Sheet.
- Microchip believes that its family of products is one of the most secure families of its kind on the market today, when used in the intended manner and under normal conditions.
- There are dishonest and possibly illegal methods used to breach the code protection feature. All of these methods, to our knowledge, require using the Microchip products in a manner outside the operating specifications contained in Microchip's Data Sheets. Most likely, the person doing so is engaged in theft of intellectual property.
- Microchip is willing to work with the customer who is concerned about the integrity of their code.
- Neither Microchip nor any other semiconductor manufacturer can guarantee the security of their code. Code protection does not mean that we are guaranteeing the product as “unbreakable.”

Code protection is constantly evolving. We at Microchip are committed to continuously improving the code protection features of our products. Attempts to break Microchip's code protection feature may be a violation of the Digital Millennium Copyright Act. If such acts allow unauthorized access to your software or other copyrighted work, you may have a right to sue for relief under that Act.

Information contained in this publication regarding device applications and the like is provided only for your convenience and may be superseded by updates. It is your responsibility to ensure that your application meets with your specifications. MICROCHIP MAKES NO REPRESENTATIONS OR WARRANTIES OF ANY KIND WHETHER EXPRESS OR IMPLIED, WRITTEN OR ORAL, STATUTORY OR OTHERWISE, RELATED TO THE INFORMATION, INCLUDING BUT NOT LIMITED TO ITS CONDITION, QUALITY, PERFORMANCE, MERCHANTABILITY OR FITNESS FOR PURPOSE. Microchip disclaims all liability arising from this information and its use. Use of Microchip devices in life support and/or safety applications is entirely at the buyer's risk, and the buyer agrees to defend, indemnify and hold harmless Microchip from any and all damages, claims, suits, or expenses resulting from such use. No licenses are conveyed, implicitly or otherwise, under any Microchip intellectual property rights unless otherwise stated.

Trademarks

The Microchip name and logo, the Microchip logo, AnyRate, dsPIC, FlashFlex, flexPWR, Heldo, JukeBlox, KeeLoq, KeeLoq logo, Klear, LANCheck, LINK MD, MediaLB, MOST, MOST logo, MPLAB, OptoLyzer, PIC, PICSTART, PIC32 logo, RightTouch, SpyNIC, SST, SST Logo, SuperFlash and UNI/O are registered trademarks of Microchip Technology Incorporated in the U.S.A. and other countries.

ClockWorks, The Embedded Control Solutions Company, ETHERSYNCH, Hyper Speed Control, HyperLight Load, IntelliMOS, mTouch, Precision Edge, and QUIET-WIRE are registered trademarks of Microchip Technology Incorporated in the U.S.A.

Analog-for-the-Digital Age, Any Capacitor, AnyIn, AnyOut, BodyCom, chipKIT, chipKIT logo, CodeGuard, dsPICDEM, dsPICDEM.net, Dynamic Average Matching, DAM, ECAN, EtherGREEN, In-Circuit Serial Programming, ICSP, Inter-Chip Connectivity, JitterBlocker, KlearNet, KlearNet logo, MiWi, motorBench, MPASM, MPF, MPLAB Certified logo, MPLIB, MPLINK, MultiTRAK, NetDetach, Omniscient Code Generation, PICDEM, PICDEM.net, PICKit, PICtail, PureSilicon, RightTouch logo, REAL ICE, Ripple Blocker, Serial Quad I/O, SQI, SuperSwitcher, SuperSwitcher II, Total Endurance, TSHARC, USBCheck, VariSense, ViewSpan, WiperLock, Wireless DNA, and ZENA are trademarks of Microchip Technology Incorporated in the U.S.A. and other countries.

SQTP is a service mark of Microchip Technology Incorporated in the U.S.A.

Silicon Storage Technology is a registered trademark of Microchip Technology Inc. in other countries.

GestIC is a registered trademarks of Microchip Technology Germany II GmbH & Co. KG, a subsidiary of Microchip Technology Inc., in other countries.

All other trademarks mentioned herein are property of their respective companies.

© 2016, Microchip Technology Incorporated, Printed in the U.S.A., All Rights Reserved.

ISBN: 978-1-5224-0908-3

QUALITY MANAGEMENT SYSTEM
CERTIFIED BY DNV
== ISO/TS 16949 ==

Microchip received ISO/TS-16949:2009 certification for its worldwide headquarters, design and wafer fabrication facilities in Chandler and Tempe, Arizona; Gresham, Oregon and design centers in California and India. The Company's quality system processes and procedures are for its PIC® MCUs and dsPIC® DSCs, KEELoq® code hopping devices, Serial EEPROMs, microperipherals, nonvolatile memory and analog products. In addition, Microchip's quality system for the design and manufacture of development systems is ISO 9001:2000 certified.



MICROCHIP

Worldwide Sales and Service

AMERICAS

Corporate Office

2355 West Chandler Blvd.
Chandler, AZ 85224-6199
Tel: 480-792-7200
Fax: 480-792-7277
Technical Support:
[http://www.microchip.com/
support](http://www.microchip.com/support)

Web Address:

www.microchip.com

Atlanta

Duluth, GA
Tel: 678-957-9614
Fax: 678-957-1455

Austin, TX

Tel: 512-257-3370

Boston

Westborough, MA
Tel: 774-760-0087
Fax: 774-760-0088

Chicago

Itasca, IL
Tel: 630-285-0071
Fax: 630-285-0075

Cleveland

Independence, OH
Tel: 216-447-0464
Fax: 216-447-0643

Dallas

Addison, TX
Tel: 972-818-7423
Fax: 972-818-2924

Detroit

Novi, MI
Tel: 248-848-4000

Houston, TX

Tel: 281-894-5983

Indianapolis

Noblesville, IN
Tel: 317-773-8323
Fax: 317-773-5453

Los Angeles

Mission Viejo, CA
Tel: 949-462-9523
Fax: 949-462-9608

New York, NY

Tel: 631-435-6000

San Jose, CA

Tel: 408-735-9110

Canada - Toronto

Tel: 905-695-1980
Fax: 905-695-2078

ASIA/PACIFIC

Asia Pacific Office

Suites 3707-14, 37th Floor
Tower 6, The Gateway
Harbour City, Kowloon

Hong Kong

Tel: 852-2943-5100
Fax: 852-2401-3431

Australia - Sydney

Tel: 61-2-9868-6733
Fax: 61-2-9868-6755

China - Beijing

Tel: 86-10-8569-7000
Fax: 86-10-8528-2104

China - Chengdu

Tel: 86-28-8665-5511
Fax: 86-28-8665-7889

China - Chongqing

Tel: 86-23-8980-9588
Fax: 86-23-8980-9500

China - Dongguan

Tel: 86-769-8702-9880

China - Guangzhou

Tel: 86-20-8755-8029

China - Hangzhou

Tel: 86-571-8792-8115
Fax: 86-571-8792-8116

China - Hong Kong SAR

Tel: 852-2943-5100
Fax: 852-2401-3431

China - Nanjing

Tel: 86-25-8473-2460
Fax: 86-25-8473-2470

China - Qingdao

Tel: 86-532-8502-7355
Fax: 86-532-8502-7205

China - Shanghai

Tel: 86-21-5407-5533
Fax: 86-21-5407-5066

China - Shenyang

Tel: 86-24-2334-2829
Fax: 86-24-2334-2393

China - Shenzhen

Tel: 86-755-8864-2200
Fax: 86-755-8203-1760

China - Wuhan

Tel: 86-27-5980-5300
Fax: 86-27-5980-5118

China - Xian

Tel: 86-29-8833-7252
Fax: 86-29-8833-7256

ASIA/PACIFIC

China - Xiamen

Tel: 86-592-2388138
Fax: 86-592-2388130

China - Zhuhai

Tel: 86-756-3210040
Fax: 86-756-3210049

India - Bangalore

Tel: 91-80-3090-4444
Fax: 91-80-3090-4123

India - New Delhi

Tel: 91-11-4160-8631
Fax: 91-11-4160-8632

India - Pune

Tel: 91-20-3019-1500

Japan - Osaka

Tel: 81-6-6152-7160
Fax: 81-6-6152-9310

Japan - Tokyo

Tel: 81-3-6880-3770
Fax: 81-3-6880-3771

Korea - Daegu

Tel: 82-53-744-4301
Fax: 82-53-744-4302

Korea - Seoul

Tel: 82-2-554-7200
Fax: 82-2-558-5932 or
82-2-558-5934

Malaysia - Kuala Lumpur

Tel: 60-3-6201-9857
Fax: 60-3-6201-9859

Malaysia - Penang

Tel: 60-4-227-8870
Fax: 60-4-227-4068

Philippines - Manila

Tel: 63-2-634-9065
Fax: 63-2-634-9069

Singapore

Tel: 65-6334-8870
Fax: 65-6334-8850

Taiwan - Hsin Chu

Tel: 886-3-5778-366
Fax: 886-3-5770-955

Taiwan - Kaohsiung

Tel: 886-7-213-7828

Taiwan - Taipei

Tel: 886-2-2508-8600
Fax: 886-2-2508-0102

Thailand - Bangkok

Tel: 66-2-694-1351
Fax: 66-2-694-1350

EUROPE

Austria - Wels

Tel: 43-7242-2244-39
Fax: 43-7242-2244-393

Denmark - Copenhagen

Tel: 45-4450-2828
Fax: 45-4485-2829

France - Paris

Tel: 33-1-69-53-63-20
Fax: 33-1-69-30-90-79

Germany - Dusseldorf

Tel: 49-2129-3766400

Germany - Karlsruhe

Tel: 49-721-625370

Germany - Munich

Tel: 49-89-627-144-0
Fax: 49-89-627-144-44

Italy - Milan

Tel: 39-0331-742611
Fax: 39-0331-466781

Italy - Venice

Tel: 39-049-7625286

Netherlands - Drunen

Tel: 31-416-690399
Fax: 31-416-690340

Poland - Warsaw

Tel: 48-22-3325737

Spain - Madrid

Tel: 34-91-708-08-90
Fax: 34-91-708-08-91

Sweden - Stockholm

Tel: 46-8-5090-4654

UK - Wokingham

Tel: 44-118-921-5800
Fax: 44-118-921-5820

06/23/16