

dTurboTMAP with SENT Output and Temperature Sensor Interface

KP275

DigitalTurboTMAP

Data Sheet

Revision 1.0, 2016-06-20

Sense & Control

Table of Contents

1	Product Description	5
1.1	Features	5
1.2	Target Applications	5
2	Functional Description	6
2.1	Pin Configuration	6
2.2	Pin Description	6
2.3	Block Diagram	7
2.4	Transfer Function Pressure	7
2.4.1	Pressure Transfer Function Characteristics	8
2.4.2	Pressure Accuracy	8
2.5	Transfer Function Temperature	9
2.5.1	Temperature Transfer Function Characteristics	9
2.6	SENT Interface	10
2.6.1	Physical Layer	10
2.6.2	Data Link Layer	10
2.6.2.1	Nibble Specification	11
2.6.2.2	Status & Communication Nibble	12
2.6.3	Pressure Channel Output Codes	15
2.6.4	Temperature Channel Output Codes	16
2.6.5	Diagnostic Error Codes	17
2.6.5.1	Signal out of range	17
2.6.5.2	Diag1	17
2.6.5.3	Diag2	18
2.6.5.4	E ² PROM Check	18
2.6.6	Definition of Pressure Signal Path Latency	18
2.7	External Temperature Sensor	19
2.7.1	Linearization of the External Temperature Sensor Transfer Function	19
2.7.2	Accuracy for NTC signal processing	19
3	Specification	20
3.1	Application Circuit Example	20
3.2	Application Circuit Example for EMC	21
3.3	Absolute Maximum Ratings	22
3.4	Operating Range	23
3.5	Characteristics	24
4	Package Information	26
4.1	PG-DSOF-8-162 Outline	26
4.2	Identification Code	27
5	Revision History	28

List of Tables

Table 1	Pin description	6
Table 2	Pressure transfer function characteristics	8
Table 3	Temperature transfer function characteristics	9
Table 4	Status nibble description	12
Table 5	Slow message channel data	14
Table 6	Pressure channel data content	15
Table 7	Error indication for Pressure channel	15
Table 8	Temperature channel data content	16
Table 9	Error indication for Temperature channel	16
Table 10	Diagnostic Error Codes	17
Table 11	NTC characteristics example	19
Table 12	Component values	20
Table 13	Component values	21
Table 14	Absolute maximum ratings	22
Table 15	Operating range	23
Table 16	General characteristics	24
Table 17	Physical layer characteristics	24
Table 18	Transfer function characteristics	25

List of Figures

Figure 1	Pin configuration (top view, figure not to scale)	6
Figure 2	Functional block diagram	7
Figure 3	Pressure transfer function.....	7
Figure 4	Accuracy for pressure acquisition	8
Figure 5	Temperature transfer function.....	9
Figure 6	Physical layer specification of a nibble	10
Figure 7	Message transmission	11
Figure 8	Nibble timing	12
Figure 9	Construction of enhanced serial data message from 18 SENT messages	13
Figure 10	Enhanced serial message format with 12-bit data field and 8-bit message ID	13
Figure 11	ESM cycle.....	14
Figure 12	Diag1 functionality	18
Figure 13	Diag2 functionality	18
Figure 14	Pressure signal path latency (pressure settling time).....	18
Figure 15	Accuracy for signal processing of NTC	19
Figure 16	Application circuit example	20
Figure 17	Application Circuit example for pulse immunity	21
Figure 18	Package outline	26
Figure 19	Identification Code	27



1 Product Description

The KP275 is a miniaturized Digital Absolute Pressure Sensor IC based on a capacitive principle. It is surface micromachined with a monolithic integrated signal conditioning circuit implemented in BiCMOS technology.

The sensor converts a pressure into a 12-bit digital value and sends the information via the SENT protocol (SAE J2716 revised Jan. 2010). In addition, an interface for an external negative temperature coefficient (NTC) temperature sensor is provided. The temperature information given by the NTC is also digitized into a 12-bit value and transmitted with the SENT protocol.

A special safety feature is the integrated diagnostic mode, which allows testing of the sensor cells as well as the signal path. This diagnosis is triggered by powering the device.

The chip is packaged in a “green” media robust SMD housing. The sensor has been primarily developed for measuring manifold air pressure, but can also be used in other application fields. The high accuracy, high sensitivity and safety features of the device makes it a perfect fit for advanced automotive applications as well as in industrial and consumer applications.

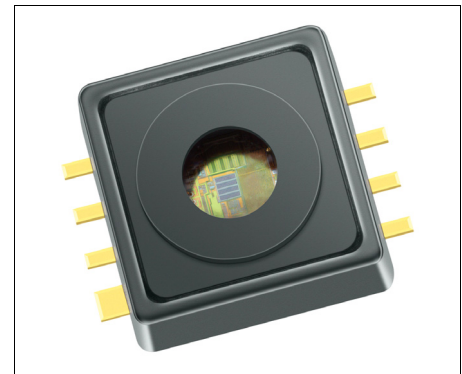

PG-DSOF-8-162

1.1 Features

The following features are provided by the KP275:

- Increased media robustness for current automotive requirements
- High accuracy pressure sensing ($\pm 0.77\%$ FSS)
- Integrated signal processing for external temperature sensor
- SENT protocol interface
- Real 12-bit pressure resolution
- Real 12-bit temperature resolution
- Self diagnosis features
- “Green” 8 pin SMD housing
- Automotive qualified

1.2 Target Applications

The KP275 is designed for use in the following target applications:

- Automotive applications, Industrial control
- Consumer applications, Medical applications

Product Name	Product Type	Ordering Code	Package
dTurboTMAP with SENT Output and Temperature Sensor Interface	KP275	SP000973736	PG-DSOF-8-162

Functional Description

2 Functional Description

2.1 Pin Configuration

Figure 1 shows the pin configuration.

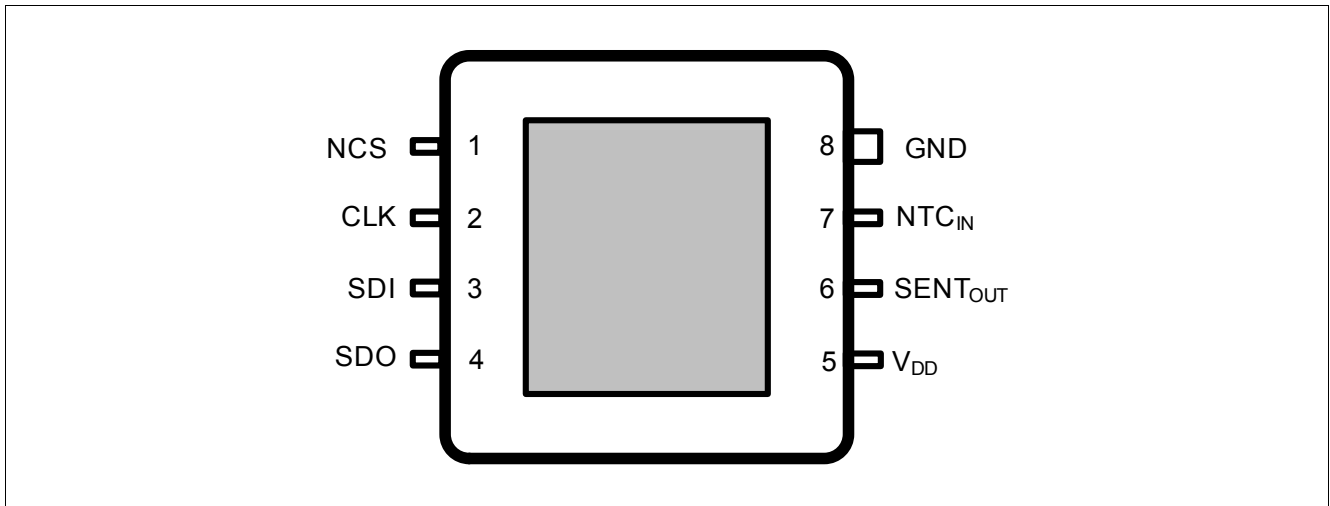

Figure 1 Pin configuration (top view, figure not to scale)

2.2 Pin Description

Table 1 shows the pin description.

Table 1 Pin description

Pin No.	Name	Function	Comment
1	NCS	Not-Chip-Select (active-low)	Communication is enabled when NCS is low ¹⁾
2	CLK	Serial Clock	External clock for serial communication ¹⁾
3	SDI	Serial Data In	Serial data input (e.g. from a controller) ¹⁾
4	SDO	Serial Data Out	Tri-state serial data output ¹⁾
5	V _{DD}	Supply voltage	–
6	SENT _{OUT}	SENT output	Digital Output of the SENT Interface
7	NTC _{IN}	NTC Input	Input pin for an external NTC
8	GND	Ground	–

1) SPI pins (pin1 - pin4) are used only during calibration and test. It is recommended to leave these pins floating in the application.

Functional Description

2.3 Block Diagram

Figure 2 shows the functional block diagram.

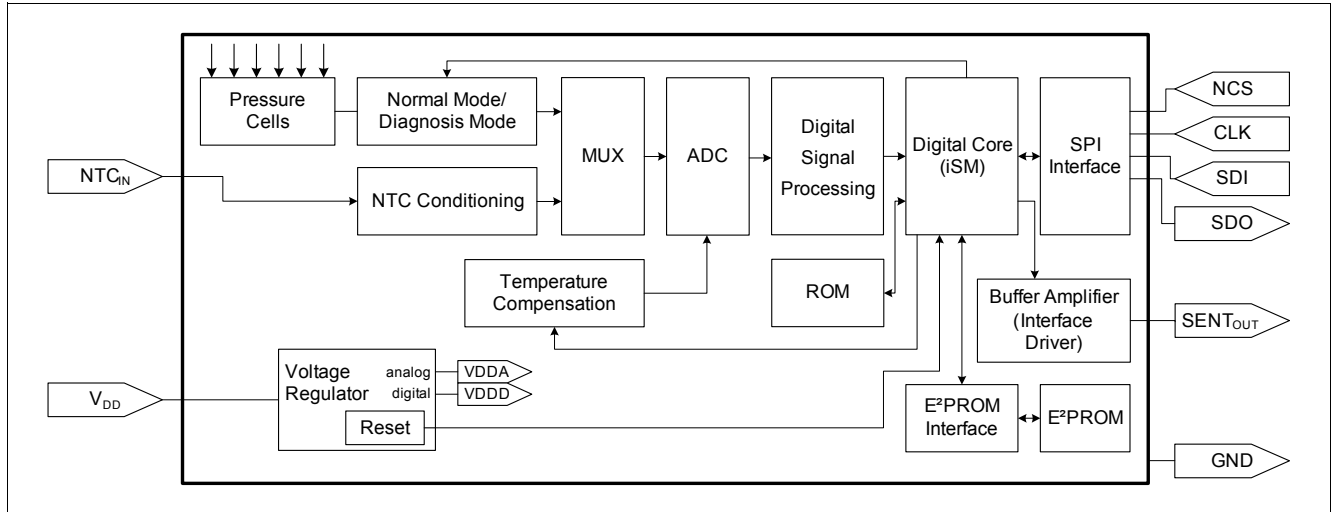

Figure 2 Functional block diagram

2.4 Transfer Function Pressure

The KP275 device is fully calibrated on delivery. The sensor has a linear transfer function between the applied pressure and the digital output signal.

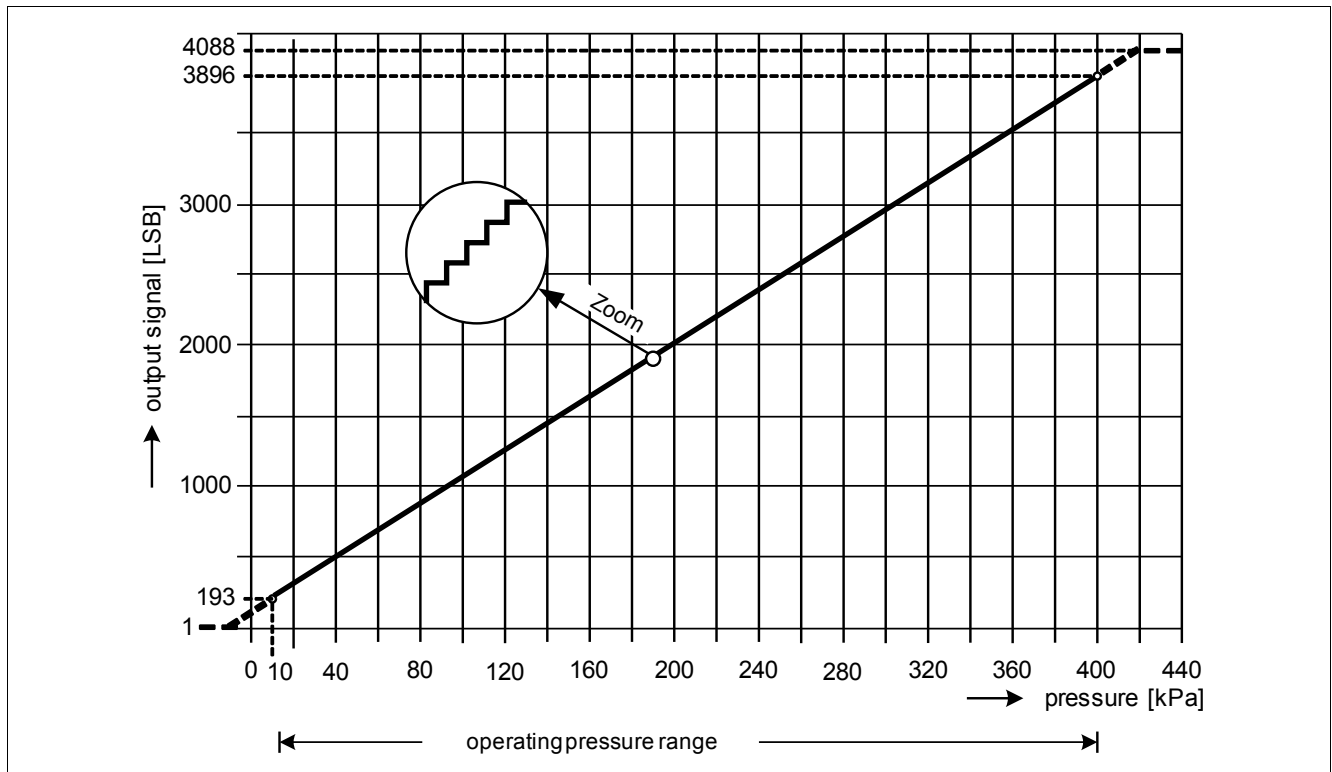

Figure 3 Pressure transfer function

Functional Description

2.4.1 Pressure Transfer Function Characteristics

The following calibration is adjusted with the parameters S_p and $offs_p$

$$p_{amb} = \frac{out_p - offs_p}{S_p}$$

Table 2 Pressure transfer function characteristics

Output Code			Pressure			Gain and Offset		
Symbol	Values	Unit	Symbol	Values	Unit	Symbol	Value	Unit
$p_{IN,1}$	10	kPa	$LSB_{OUT,1}$	193	LSB	S_p	9.495	LSB/kPa
$p_{IN,2}$	400	kPa	$LSB_{OUT,2}$	3896	LSB	offsp	98.05	LSB

Clamping

The output signal for pressure is limited internally to clamping level low (output code 1) and clamping level high (output code 4088).

2.4.2 Pressure Accuracy

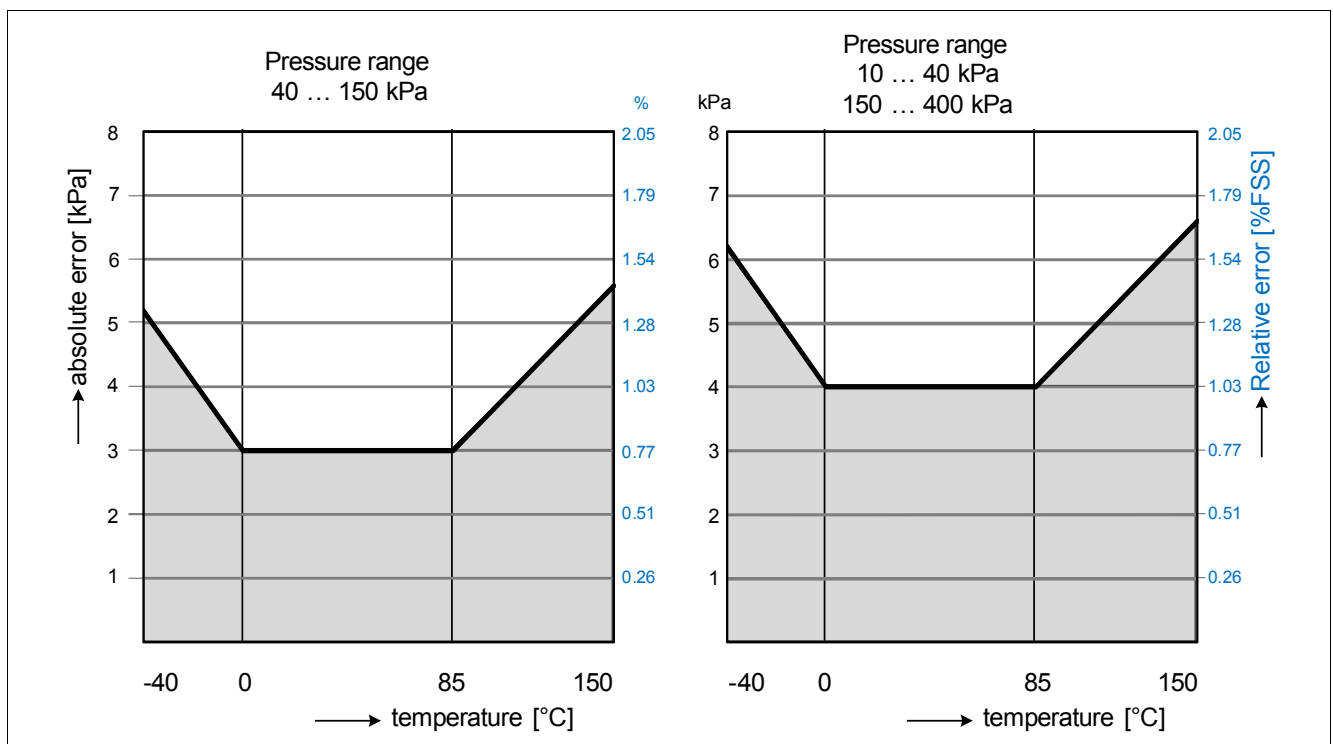

Figure 4 Accuracy for pressure acquisition

Functional Description

2.5 Transfer Function Temperature

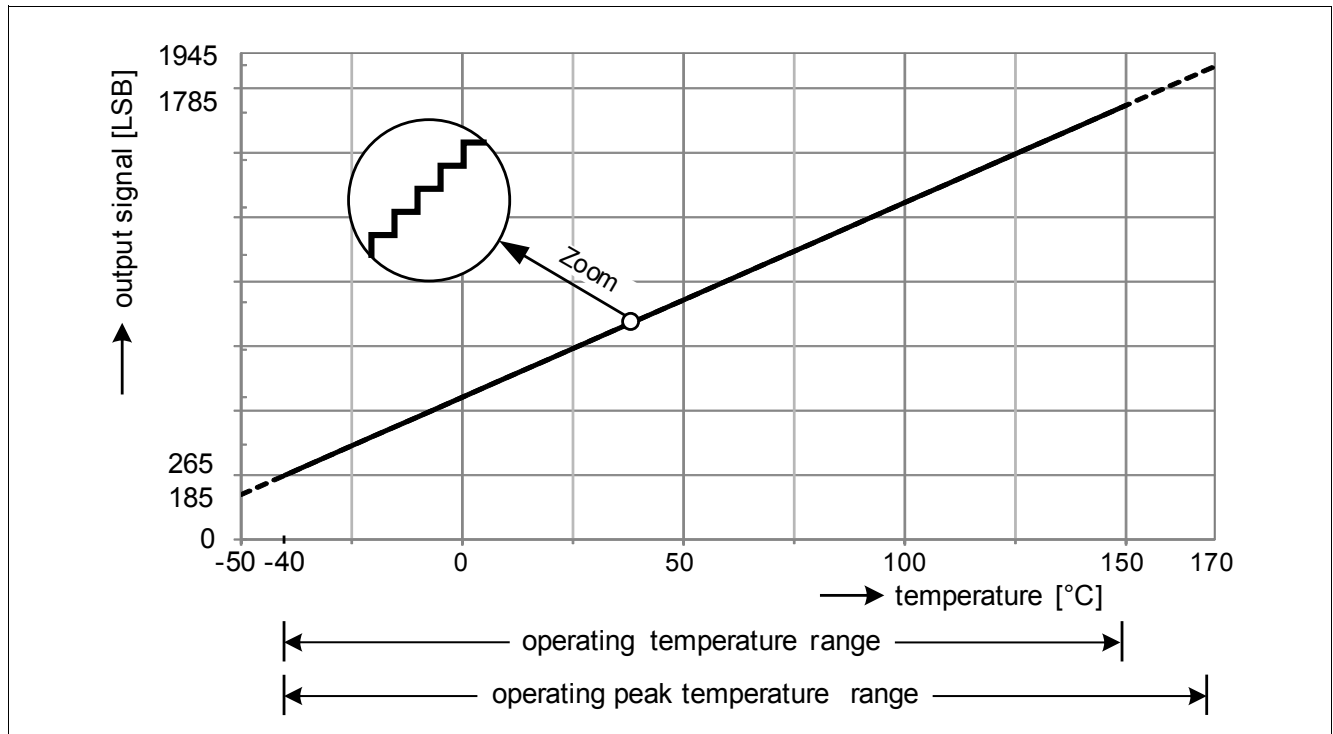

Figure 5 Temperature transfer function

2.5.1 Temperature Transfer Function Characteristics

The following calibration is adjusted with the parameters S_T and $offs_T$:

$$T_{amb} = \frac{out_T - offs_T}{S_T}$$

Table 3 Temperature transfer function characteristics

Temperature			Output Code			Gain and Offset		
Symbol	Values	Unit	Symbol	Values	Unit	Symbol	Value	Unit
$T_{IN,1}$	-40	°C	$LSB_{OUT,1}$	265	LSB	ST	8.0	LSB/°C
$T_{IN,2}$	170	°C	$LSB_{OUT,2}$	1945	LSB	offsT	585.2	LSB

Functional Description

2.6 SENT Interface

The SENT interface enables communication according to the SENT (Single Edge Nibble Transmission) Specification. The SENT protocol specifies the transmission of information in a series of pulses with data encoded as falling edge to falling edge periods. Each following pulse is called a nibble. The SENT interface transmits messages organized in frames. Each frame consists of several pulses which are delimited by falling edges. Each falling edge marks the start of a new nibble.

2.6.1 Physical Layer

The physical layer provides the method of transferring digital data encoded as time between two falling edges of a signal through the communication medium. It consists of power, ground and the signal wire (see [Figure 16 “Application circuit example” on Page 20](#)).

The basic unit of time for the SENT interface is called a clock tick. The transmission bit rate depends on the data value sent and the sensor clock tolerance. The shortest length of a nibble pulse consists of 12 ticks (nominally 36 μs), the maximum length is 27 ticks (nominally 81 μs).

[Figure 6](#) shows the physical layer specification of a nibble.

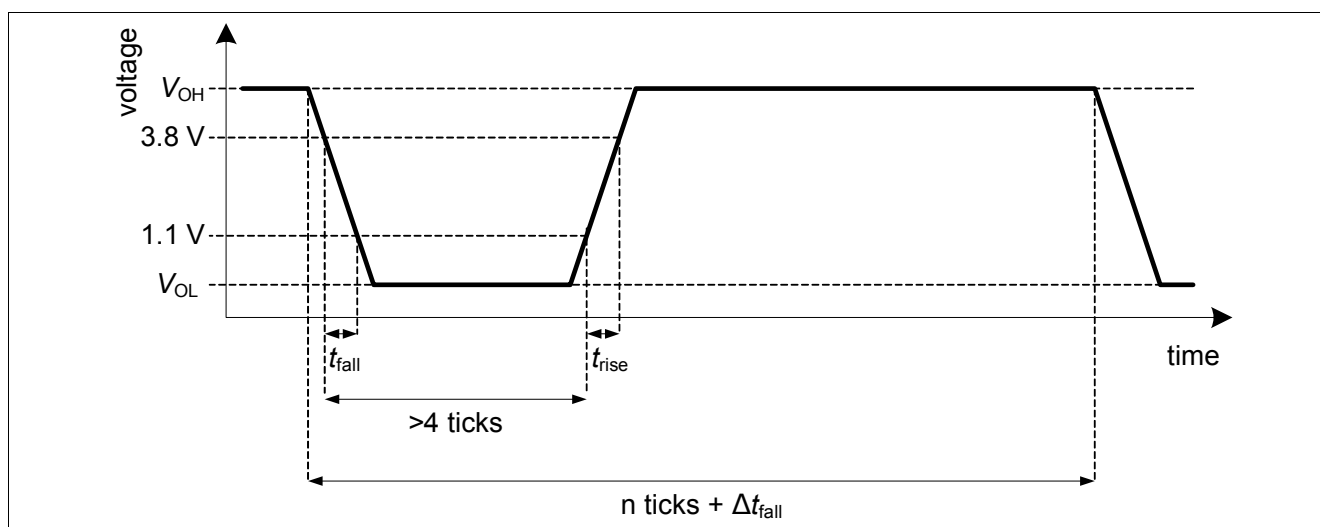

Figure 6 Physical layer specification of a nibble

2.6.2 Data Link Layer

The SENT interface has two channels for transmitting information:

- Fast Channel
- Slow Channel

The fast channel represents the information transmitted in the data pulses of the SENT frame. Within a single SENT frame a full pressure code and full NTC code is transmitted.

The slow channel represents the information transmitted within the Status and Serial Communication nibble. On this channel information is transmitted over several SENT frames (4 bits per SENT frame). This information consists of diagnostic codes and serial messages.

Functional Description

The SENT frame starts with a Synchronization and Calibration pulse which is used by the receiver to synchronize with the frame and to create a reference for the length measurement of the following nibbles.

The Synchronization pulse is followed by a Status and Serial Communication nibble. The value coded in this nibble represents a series of 4 bits. While bit #0 and bit #1 are reserved, bit #2 and bit #3 are used to communicate serial messages.

The message transmitted by the KP275 comprehends two fast channels. Each channel is segmented in 3 data nibbles; every nibble includes 4 bits. The 12 bit pressure information is transmitted by the first fast channel, the 12 bit temperature information of the NTC by the second fast channel.

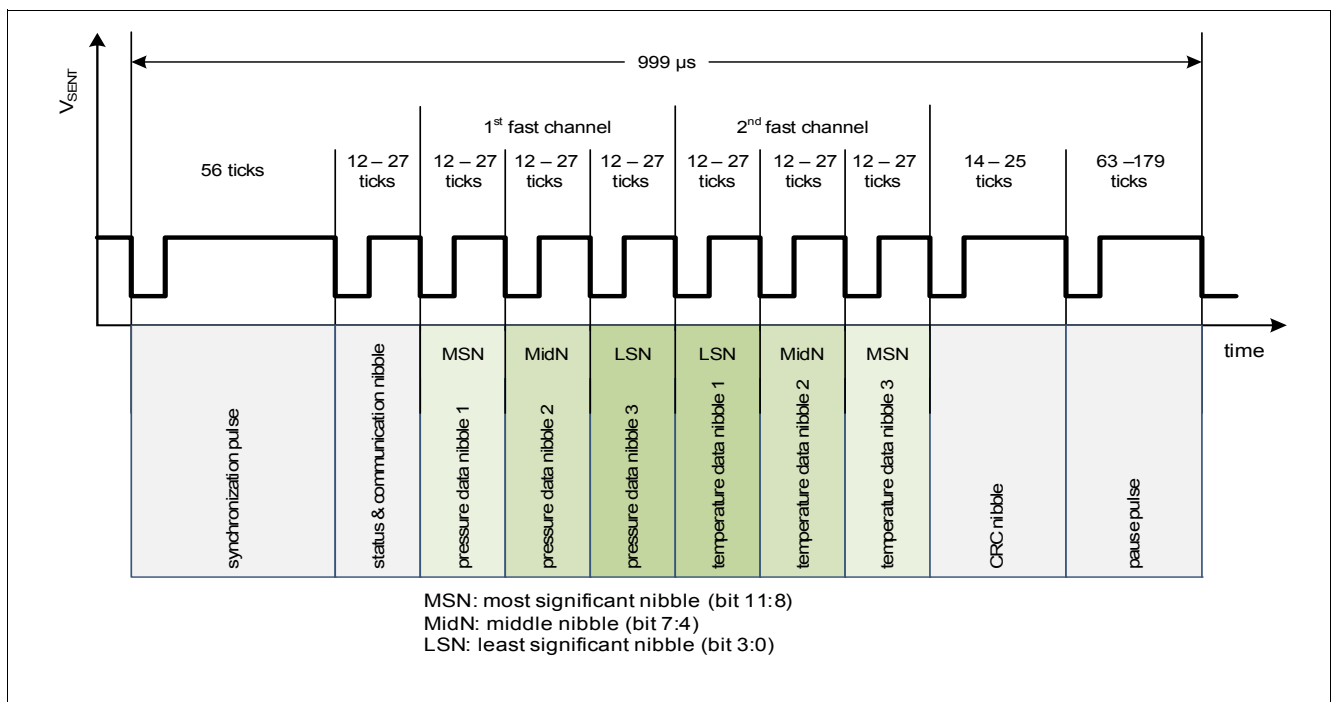

Figure 7 Message transmission

The pause pulse is used to create a SENT transmission with a constant frame length of 333 clock ticks (999 μs).

2.6.2.1 Nibble Specification

A nibble contains 4 bit data content. The length of a nibble defines the content of the 4 bits. The global timing of a nibble is based on ticks. The length of a tick is specified as 3 μs .

The following formula defines the number of ticks (n_{ticks}) based on the nibble content ($data_{nibble}$).

$$n_{ticks} = 12 + data_{nibble}$$

Figure 8 shows the nibble timing.

Functional Description

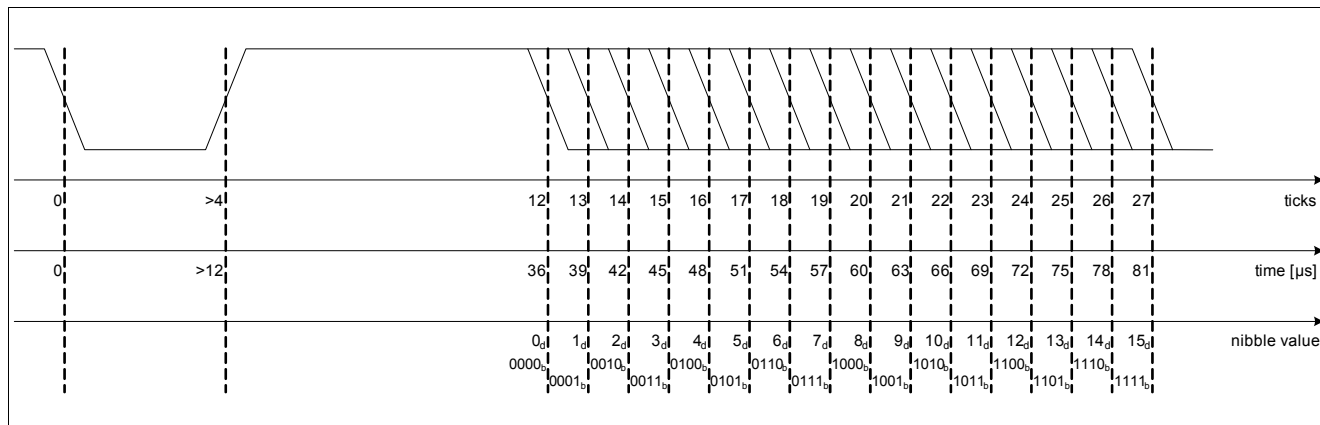

Figure 8 Nibble timing

2.6.2.2 Status & Communication Nibble

This nibble is reserved to enable the sensor to transmit different information such as part numbers or error code information. The nibble is defined in the following table:

Table 4 Status nibble description

Status Nibble Bit	Function
0	Pressure channel error flag
1	Temperature channel error flag
2	Serial message bit: Serial message data bit
3	Serial message bit: Indicates the start of a serial message

The serial message channel (slow message channel) is implemented as enhanced serial message format.

2.6.2.2.1 Enhanced Serial Message Format

Bit #2 and #3 of the status and communication nibble are used for serial data transmission. A serial message stretches over 18 consecutive SENT data messages. All 18 messages must be successfully received for the serial value to be valid.

The frame start of a serial message is indicated by the unique pattern “111110” in bit #3 of the status and communication nibble, **Figure 10**. The first “1” in a series of six “1” (after a “0”) indicates the first nibble of a serial message. Serial data bit #3 of serial communication nibble 1 - nibble 6 are set to “1”, Serial data bit #3 of serial communication nibbles 7, 13 and 18 are set to “0”.

The serial message contains 20 bits of payload data. The communication is defined by the configuration bit (serial data bit #3, serial communication nibble No.8), configuration bit = 0”:

- 12 bit data and 8 bit message ID

Functional Description

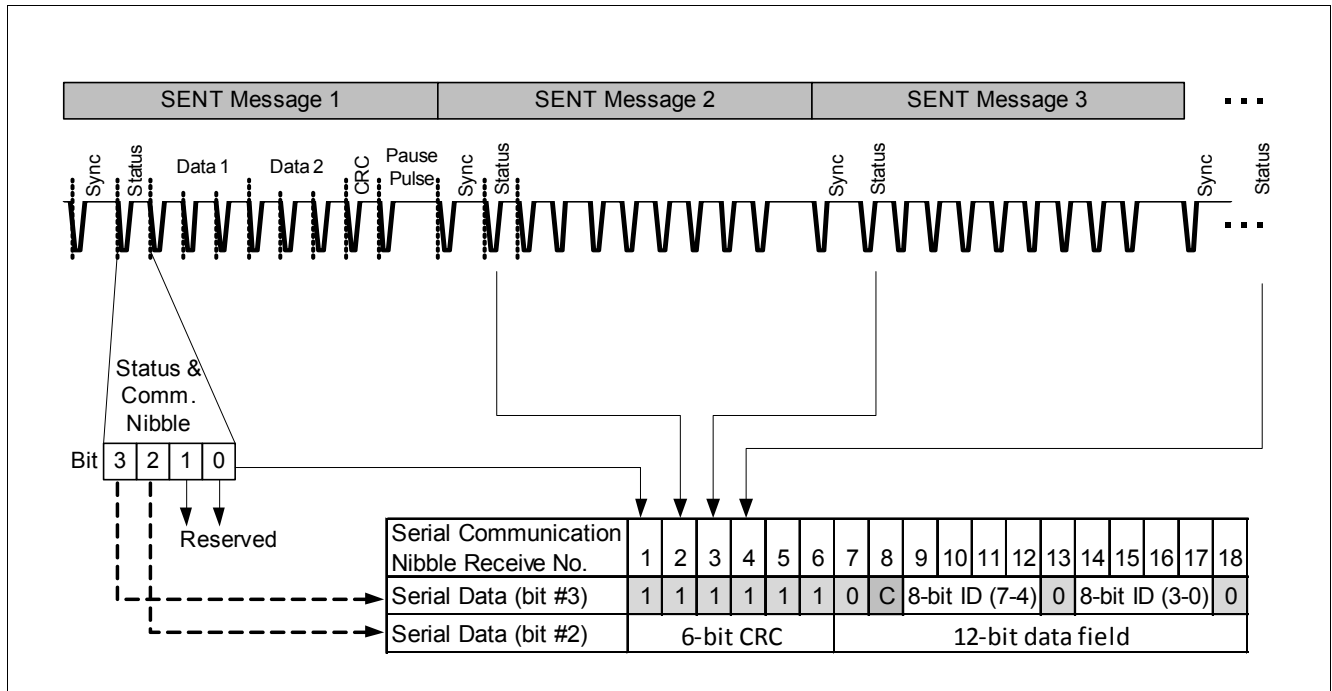

Figure 9 Construction of enhanced serial data message from 18 SENT messages

All data (data field, message ID and CRC) that is transmitted in the serial message channel is sent in the order MSB to LSB.

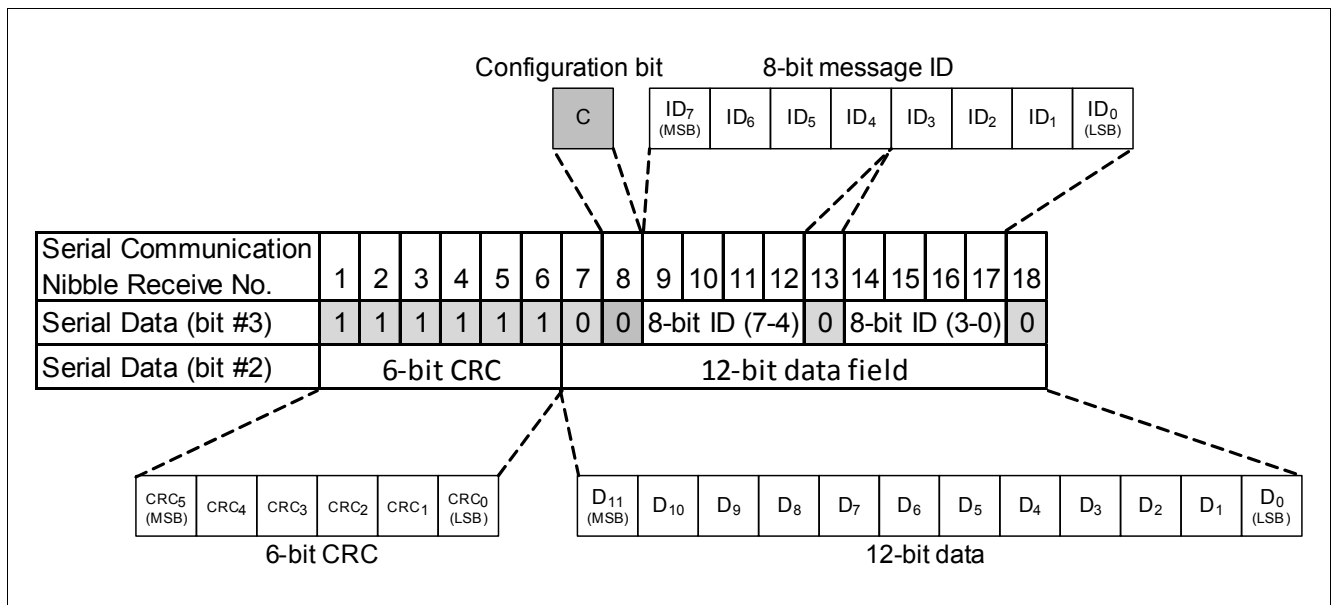

Figure 10 Enhanced serial message format with 12-bit data field and 8-bit message ID

Functional Description

2.6.2.2.2 Enhanced Serial Message Data

The following 28 serial messages are transmitted over the slow channel and continuously repeated:

Table 5 Slow message channel data

Message Number	Message ID	Definition	12 bit data	EEPROM programmable
1	\$01	Diagnostic error codes	-	-
2	\$03	Sensor type Channel 1/2 Pressure/Temperature	0x007	no
3	\$04	Configuration Code	0x001	no
4	\$05	Manufacturer Code	0x049	no
5	\$06	SENT standard version	0x003	no
6	\$07	Fast channel 1 characteristic $X_1, (X_1=p_{IN,1})$	0x053	yes
7	\$08	Fast channel 1 characteristic $X_2, (X_2=p_{IN,2})$	0x144	yes
8	\$01	Diagnostic error codes	-	-
9	\$81	defined by OEM/Supplier		yes
10	\$23	Supplementary data channel #4,1	0x000	no
11	\$09	Fast channel characteristic Y_1 , default	0x0C1	no
12	\$0A	Fast channel characteristic Y_2 , default	0xF38	no
13	\$29	Sensor ID #1		yes
14	\$80	defined by OEM/Supplier		yes
15	\$01	Diagnostic error codes	-	-
16	\$2A	Sensor ID #2		yes
17	\$2B	Sensor ID #3		yes
18	\$2C	Sensor ID #4		yes
19	\$82	OEM/Supplier	0x000	no
20	\$90	OEM part number	0x000	no
21	\$91	OEM part number	0x000	no
22	\$01	Diagnostic error codes	-	-
23	\$92	OEM part number	0x000	no
24	\$93	OEM part number	0x000	no
25	\$94	OEM part number	0x000	yes
26	\$95	OEM part number	0x000	yes
27	\$96	OEM part number	0x000	yes
28	\$97	OEM part number	0x000	yes

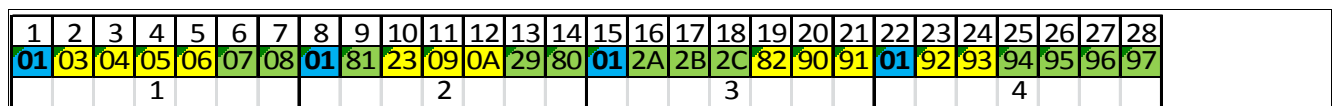

Figure 11 ESM cycle

Functional Description

2.6.3 Pressure Channel Output Codes

Table 6 gives an overview about the pressure channel data content.

Table 6 Pressure channel data content

Code [dec]	Code [bin]	Data Nibble 1	Data Nibble 2	Data Nibble 3	Description
0	0000 0000 0000	12 ticks	12 ticks	12 ticks	invalid value
1	0000 0000 0001	12 ticks	12 ticks	13 ticks	Clamping low
2	0000 0000 0010	12 ticks	12 ticks	14 ticks	min. pressure output
...
4087	1111 1111 0111	27 ticks	27 ticks	19 ticks	max. pressure output
4088	1111 1111 1000	27 ticks	27 ticks	20 ticks	Clamping high
4089	1111 1111 1001	27 ticks	27 ticks	21 ticks	invalid value
4090	1111 1111 1010	27 ticks	27 ticks	22 ticks	diagnostic error
4091	1111 1111 1011	27 ticks	27 ticks	23 ticks	invalid value
4092	1111 1111 1100	27 ticks	27 ticks	24 ticks	invalid value
4093	1111 1111 1101	27 ticks	27 ticks	25 ticks	invalid value
4094	1111 1111 1110	27 ticks	27 ticks	26 ticks	invalid value
4095	1111 1111 1111	27 ticks	27 ticks	27 ticks	invalid value

Table 7 Error indication for Pressure channel

Pressure kPa	Fast channel 1 LSB	slow channel ID\$01	Status Nibble Bit 0	Description
$P < -10$	1	002 _H	1	clamping low
$-10 \leq P < 10$	$2 \leq \text{code} \leq 192$	002 _H	0	reduced signal accuracy
$10 \leq P \leq 400$	$193 \leq \text{code} \leq 3896$	000 _H	0	signal range
$400 < P < 420$	$3897 \leq \text{code} \leq 4087$	001 _H	0	reduced signal accuracy
$420 \leq P$	4088	001 _H	1	clamping high

Note: Status Nibble Bit #0 is calculated at start of every frame. Status value for slow channel is calculated at start of every slow channel status message (ID\$01).

Functional Description

2.6.4 Temperature Channel Output Codes

Table 8 gives an overview about the temperature channel data content.

Table 8 Temperature channel data content

Code [dec]	Code [bin]	Data Nibble 3	Data Nibble 2	Data Nibble 1	Description
0	0000 0000 0000	12 ticks	12 ticks	12 ticks	initialization
1	0000 0000 0001	12 ticks	12 ticks	13 ticks	-73°C
...
185	0000 1011 1001	12 ticks	23 ticks	21 ticks	min. temperature ¹⁾ (-50°C)
...
2025	0111 1110 1001	19 ticks	26 ticks	21 ticks	max. temperature ¹⁾ (180°C)
...
4088	1111 1111 1000	27 ticks	27ticks	20 ticks	438°C
4089	1111 1111 1001	27 ticks	27 ticks	21 ticks	invalid value
4090	1111 1111 1010	27 ticks	27 ticks	22 ticks	diagnostic error
4091	1111 1111 1011	27 ticks	27 ticks	23 ticks	invalid value
4092	1111 1111 1100	27 ticks	27 ticks	24 ticks	invalid value
4093	1111 1111 1101	27 ticks	27 ticks	25 ticks	invalid value
4094	1111 1111 1110	27 ticks	27 ticks	26 ticks	invalid value
4095	1111 1111 1111	27 ticks	27 ticks	27 ticks	invalid value

1) min/max temperature output depends on external NTC due to limitation of measurement range for NTC resistance, see Table 18

Table 9 Error indication for Temperature channel

Temperature ¹⁾ °C	Fast channel 2 LSB	slow channel ID\$01	Status Nibble Bit 1	Description
T < -50	code < 185	805 _H	1	Temperature too low
-50 ≤ T < -40	185 ≤ code ≤ 265	000 _H	0	Accuracy undefined
-40 ≤ T ≤ 170	266 ≤ code ≤ 1945	000 _H	0	Temperature range
170 < T ≤ 180	1946 ≤ code ≤ 2025	000 _H	0	Accuracy undefined
T > 180	code > 2025	804 _H	1	Temperature too high

Note:

1. The output code for fast channel 2 is limited by the NTC resistance value.
2. Status Nibble Bit #1 is calculated at start of every frame. Status value for slow channel is calculated at start of every slow channel status message (ID\$01).

Functional Description

2.6.5 Diagnostic Error Codes

After power on, a system self check is started. During this initialization phase the following internal sensor checks are performed:

- Pressure out of range
- Signal path check (Diag1)
- Sensor cell check (Diag2)
- E²PROM check

The signal range is continuously monitored and ‘Signal out of range’ is transmitted with every SENT frame. Pressure out of range is transmitted over fast channel1, temperature out of range is transmitted over fast channel2

If an internal malfunction is detected, the error code 4090 is transmitted over fast channel1 and fast channel2. The error type is transmitted over the slow message channel (Diagnostic Error Code), see [Table 10](#). If more than one error is detected, only the diagnosis code with the highest priority will be sent.

Table 10 Diagnostic Error Codes

Description	Priority ¹⁾	Fast Channel1 Code	Fast Channel2 Code	Diagnostic Error Code
Normal Operation/Initialization		data	data	000 _H no error
Internal Error	5	4090	4090	A05 _H
Pressure out of range high	4	4088		001 _H
Pressure out of range low	3	1		002 _H
Temperature out of range high	2		>2025	804 _H
Temperature out of range low	1		<185	805 _H

1) Priority 5: high, priority 1: low

Note: Diagnostic error code is updated with start of every new status message ID.

2.6.5.1 Signal out of range

The signal ranges are monitored during normal operation mode. If the pressure value is below the minimum operating pressure range or exceeds the maximum operating pressure range the error code “Pressure out of range low/high” is transmitted. The limits are defined in [Table 7](#).

If the NTC temperature is below the minimum operating temperature or NTC resistor exceeds the maximum resistance value of NTC “Temperature out of range low” is transmitted. If the NTC temperature exceeds the maximum operating temperature or NTC resistor is below minimum resistance value the error code “Temperature out of range high” is transmitted. The limits are defined in [Table 9](#), the resistance values of NTC are defined in [Table 18](#).

2.6.5.2 Diag1

The Diag1 test checks the functionality of the signal path. Therefore the inputs of the sigma delta ADC are shorted. Afterwards, the system response is compared with the expected range (~ 50% of full scale range). If the system response is out of range, the diagnostic error code “Internal Error” is set.

Functional Description

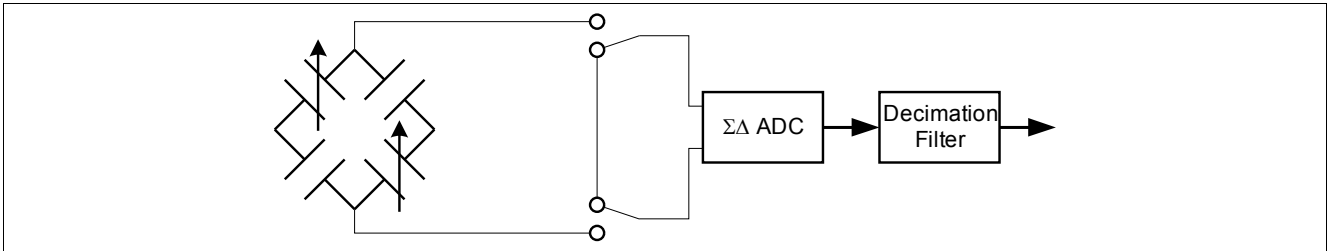

Figure 12 Diag1 functionality

2.6.5.3 Diag2

The Diag2 test checks the functionality of the pressure sensor cells. Therefore a malfunction (e.g. broken membrane) can be detected. The KP275 pressure sensing element is made of 2 measuring cells and 2 reference cells. In the normal mode these four cells are connected in a Wheatstone bridge configuration. In the Diag2 mode, the connection of the cells is modified as shown in **Figure 13**. If Diag2 value is out of range, the diagnostic error code “Internal Error” is set.

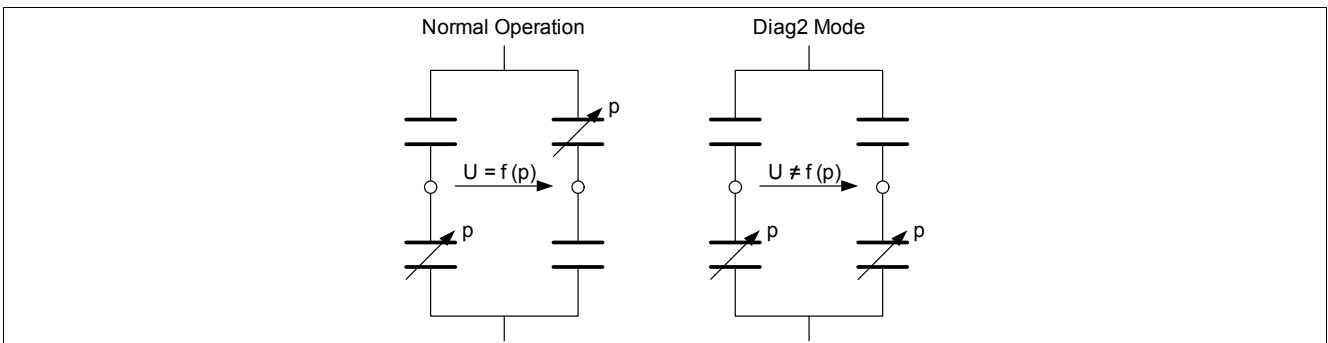

Figure 13 Diag2 functionality

2.6.5.4 E²PROM Check

During the initialization phase the content of the E²PROM cells is copied into the corresponding E²PROM registers. Thereby, a parity check is done based on the parity row and column. A one bit error is corrected by the forward error correction. Any additional bit error results in an “Internal Error”.

2.6.6 Definition of Pressure Signal Path Latency

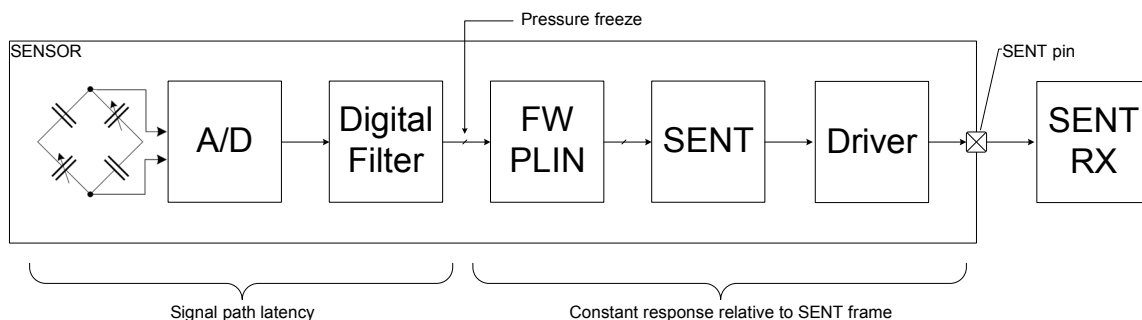

Figure 14 Pressure signal path latency t_{path_pres} (pressure settling time)

The pressure value is calculated at start of the SENT frame and is transmitted once per frame.

Functional Description

2.7 External Temperature Sensor

The KP275 can be connected to an external temperature sensor at pin NTC_{IN}. A reference voltage is applied to the NTC and the current through the NTC is used to determine the temperature. The internal signal processing of the KP275 makes it a perfect fit for using standard NTC temperature sensors. The current through the NTC is changed in a way to have a linear temperature transfer function within the SENT protocol. To avoid errors through self heating of the NTC, the power consumption is limited.

2.7.1 Linearization of the External Temperature Sensor Transfer Function

The resistance of NTC thermistors is a nonlinear function of the temperature. The used method for mathematical modelling of the resistance R versus temperature T is the **Steinhart-Hart Equation**:

$$\frac{1}{T} = A + B(\ln(R)) + C(\ln(R))^3$$

The Steinhart-Hart coefficients for a selected NTC are coded in the E²PROM. Evaluation of accuracy is included for the following thermistor:

Table 11 NTC characteristics example

					Steinhart-Hart coefficients		
	R _{min} [Ohm]	T [°C]	R _{max} [Ohm]	T [°C]	A	B	C
NTC	99	170	109945	-40	1.10937E-03	2.44772E-04	2.28348E-07

Note: The resistance range of the NTC is limited, see [Table 18](#).

2.7.2 Accuracy for NTC signal processing

The accuracy of the signal processing for external temperature sensors depends on the resistance value and the nonlinearity of the connected NTC. In [Figure 15](#) the absolute error is displayed graphically, all errors due to the integrated signal processing are considered.

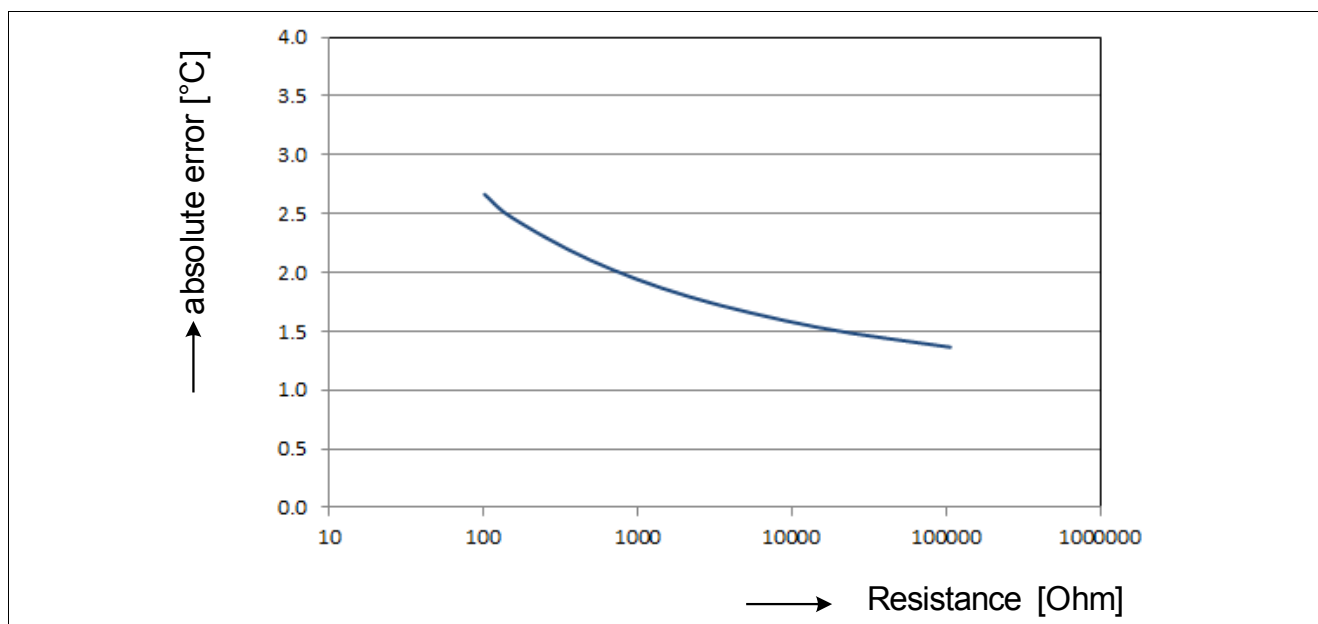

Figure 15 Accuracy for signal processing of NTC

Specification

3 Specification

3.1 Application Circuit Example

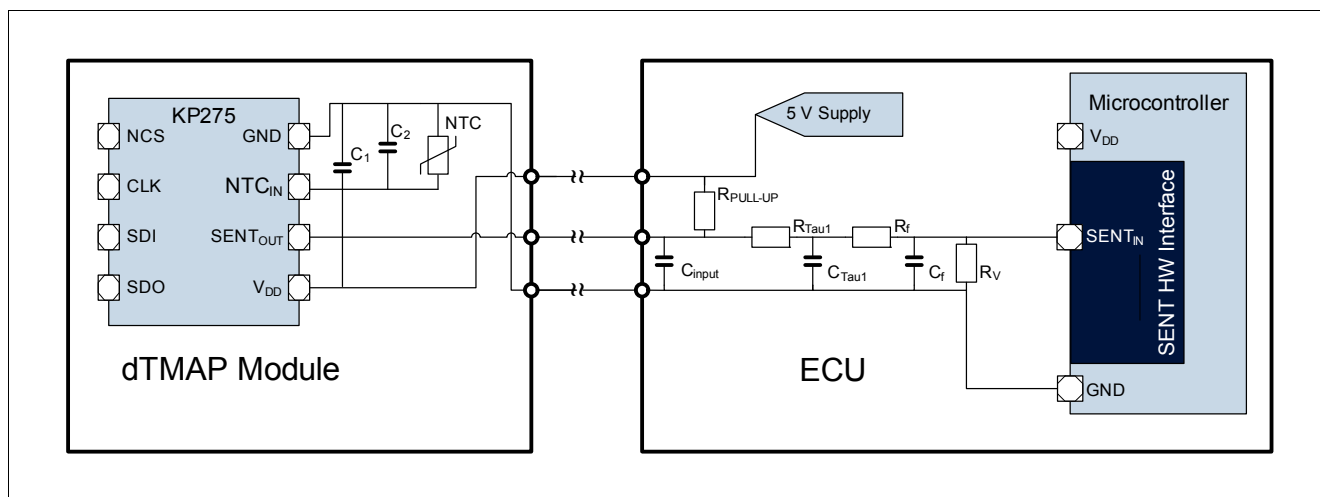

Figure 16 Application circuit example

Table 12 Component values

Component	Symbol	Values			Unit
		Min.	Typ.	Max.	
Supply Blocking Capacitor	C_1	30	100	–	nF
NTC Capacitor	C_2	–	330	–	pF
Pull-up Resistor	$R_{PULL-UP}$	10	–	55	KOhm
Parasitic Input Capacitor	C_{input}	–	–	0.1	nF
Low Pass Resistor	R_{Tau1}	448	560	672	Ohm
Low Pass Capacitor	C_{Tau1}	1.54	2.2	2.86	nF
Low Pass Resistor - second stage	R_f	4	–	–	KOhm
Low Pass Capacitor - second stage	C_f	–	47	–	pF
optional resistor	R_v	–	100	–	KOhm
Filter Time Constant - first stage, determined by R_{Tau1} and C_{Tau1}	Tau1	0.74	–	1.73	μ s
Filter Time Constant - second stage, determined by R_v , R_f and C_f	Tau2	0.6	–	1.4	μ s

Attention: For the application PCB-layout, it is mandatory to route the NTC GND wire in such a way that the chip current or any other current does not run through any of the NTC input connections. Star ground connection is recommended for the NTC-GND and GND of the supply source. This will reduce the additional external voltage drop that could influence the external NTC accuracy.

Specification

3.2 Application Circuit Example for EMC

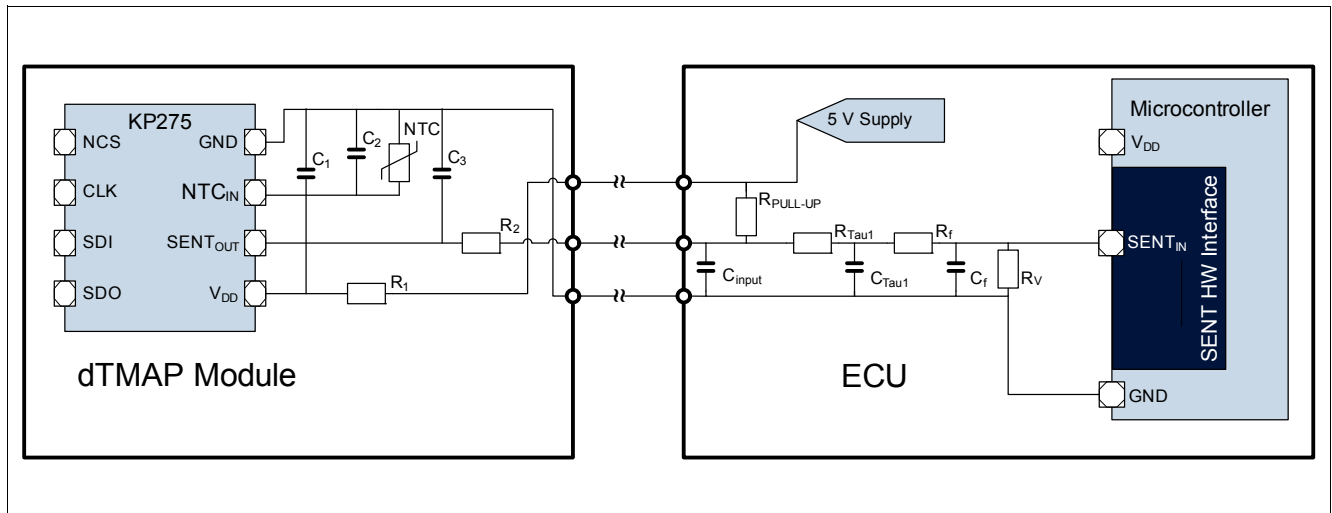

Figure 17 Application Circuit example for pulse immunity

Table 13 Component values

Component	Symbol	Values			Unit
		Min.	Typ.	Max.	
Supply Blocking Capacitor	C_1	–	330	–	nF
NTC Capacitor	C_2	–	330	–	pF
SENT Filter Capacitor	C_3	–	1	–	nF
Supply Filter Resistor	R_1	–	10	–	Ohm
SENT Filter Resistor	R_2	–	100	–	Ohm

For pulse immunity an EMC filter consisting of a capacitor (C_3) followed by a resistor in series (R_2) with the SENT_{OUT} Pin is recommended to attenuate RF energy coupled on the external signal line. In addition a filter consisting of the adapted supply capacitor (C_1) followed by a resistor in series (R_1) with the Supply Pin is recommended to attenuate RF energy coupled on the external supply line.

Specification

3.3 Absolute Maximum Ratings

Table 14 Absolute maximum ratings

Parameter	Symbol	Values			Unit	Note	Number
		Min.	Typ.	Max.			
Voltage on GND & SENT _{OUT}	V _{max}	-0.3	–	16	V	–	1.1
Voltage on V _{DD}	V _{max_VDD}	-16	–	16	V	Reverse polarity protection against supply	1.2
Storage temperature	T _S	-40	–	150	°C	–	1.3
Maximum input pressure	p _{amb_max}	–	–	500 600	kPa kPa	Limited time: Max. 300 s	1.4
ESD robustness	V _{ESD}	–	–			Human Body Model R=1.5 kΩ, C=100pF	1.5
Pins: VDD, GND, SENT _{out} , NTC _{in}				4	kV		
Pins: NCS, CLK, SDI, SDO				2	kV		

Attention: Stresses above the max. values listed in Table 14 “Absolute maximum ratings” on Page 22 may cause permanent damage to the device. Exposure to absolute maximum rating conditions for extended periods may affect device reliability. Maximum ratings are absolute ratings; exceeding only one of these values may cause irreversible damage to the integrated circuit.

Note: The Voltage on SENT_{OUT} must not exceed the Voltage on the V_{DD} Pin.

Specification

3.4 Operating Range

The following operating conditions must not be exceeded in order to ensure correct operation of the device. All parameters specified in the following sections refer to these operating conditions, unless noted otherwise.

Table 15 Operating range

Parameter	Symbol	Values			Unit	Note	Number
		Min.	Typ.	Max.			
Supply voltage	V_{DD}	4.5	5.0	5.5	V	–	2.1
Supply voltage power up/power down gradient	V_{grad}	1E-5	–	1E4	V/ms	–	2.2
Input voltage for low level at pins NCS, CLK & SDI	V_{low_in}	-0.3	–	0.8	V	–	2.3
Input voltage for high level at pins NCS, CLK & SDI	V_{high_in}	2.0	–	3	V	–	2.4
Output voltage for low level at pin SDO	V_{low_out}	–	–	0.4	V	Test current at pin SDO is 1.5mA	2.5
Output voltage for high level at pin SDO	V_{high_out}	VDD - 0.4	–	VDD	V	Test current at pin SDO is 1.5mA	2.6
Operating temperature	T_a	-40	–	+150	°C	–	2.7
Operating peak temperature	T_{a_peak}	–	–	+170	°C	Limited time: Max. 20 min.	2.8
Ambient operating pressure range	p_{amb}	10	–	400	kPa	–	2.9
Thermal resistance	$R_{thj-pin}$	–	–	180	K/W	Thermal resistance between the die and the pins, according to JESD51-2	2.10
Lifetime ¹⁾	t_{live}	15	–	–	years	–	2.11
Operating time	t_{op}	–	–	10000	h	–	2.12

1) The life time shall be considered as anticipation with regard to the product that shall not extend the agreed warranty period.

Attention: The sensor must be operated in darkness. No exposure to light.

Specification

3.5 Characteristics

Product characteristics involve the spread of values guaranteed within the specified voltage and ambient temperature range. Typical characteristics are the median of the production.

Table 16 General characteristics

Parameter	Symbol	Values			Unit	Note	Number
		Min.	Typ.	Max.			
Supply current into VDD ¹⁾	I_{VDD}	–	9	– 15	mA mA	no NTC connected, no SENT filter NTC shorted to GND and SENT filter connected	3.1
Internal pressure update rate	f_{update}	–	250	–	kHz	–	3.2
Pressure signal path latency ²⁾	t_{path_pres}	–	1	2	ms	–	3.3
Temperature signal path latency	t_{path_temp}	–	100	500	ms	NTC update rate	3.4
Start-up time ³⁾ Pressure	$t_{start-up_pres}$	–	10	12	ms	for pressure channel	3.5
Start-up time Temperature	$t_{start-up_temp}$	–	300	500	ms	for temperature channel	3.6

- 1) supply current depends on NTC resistor: additional current of approximately 2mA has to be considered with min R_{NTC} (40 Ohm) connected
- 2) for more details see, [Chapter 2.6.6](#)
- 3) time from power-up until SENT transmission start

Table 17 Physical layer characteristics

Parameter	Symbol	Values			Unit	Note	Number
		Min.	Typ.	Max.			
Low state voltage level on $SENT_{OUT}$	V_{OL}	–	–	0.5	V	0.1 mA DC load current	4.1
High state voltage level on $SENT_{OUT}$	V_{OH}	4.1	–	5.5	V	0.1 mA DC load current	4.2
Length of one tick	t_{tick}	–	3.0	–	μ s	–	4.3
Clock tick time variation	$tick_{var}$	-20	–	18	%	–	4.4
Nibble fall time	t_{fall}	–	–	6.5	μ s	From 3.8 V to 1.1 V	4.5
Nibble rise time	t_{rise}	–	–	18.0	μ s	From 1.1 V to 3.8 V	4.6

Specification

Table 17 Physical layer characteristics (cont'd)

Parameter	Symbol	Values			Unit	Note	Number
		Min.	Typ.	Max.			
Jitter	Δt_{fall}	–	–	0.1	μs	Edge to edge with static environment for any pulse period	4.7
Signal stabilization time	t_{stable}	6	–	–	μs	Signal stabilization time below 1.39 V or above 3.8 V	4.8

Table 18 Transfer function characteristics

Parameter	Symbol	Values			Unit	Note	Number
		Min.	Typ.	Max.			
Sensitivity pressure	Sp	–	9.495	–	LSB /kPa	–	5.1
Offset pressure	offsp	–	98.05	–	LSB	–	5.2
Sensitivity temperature	ST	–	8.0	–	LSB /°C	–	5.3
Offset temperature	offsT	–	585.2	–	LSB	–	5.4
Accuracy pressure 40 kPa - 150 kPa	acc_{p_mid}	-3.0 -5.2 -5.6	–	3.0 5.2 5.6	kPa	0°C - 85°C @-40°C @150°C	5.5a
Accuracy pressure 10 kPa - 40 kPa	acc_{p_low}	-4.0 -6.2 -6.6	–	4.0 6.2 6.6	kPa	0°C - 85°C @-40°C @150°C	5.5b
Accuracy pressure 150 kPa - 400 kPa	acc_{p_high}	-4.0 -6.2 -6.6	–	4.0 6.2 6.6	kPa	0°C - 85°C @-40°C @150°C	5.5c
Resistance value of NTC	R_{NTC}	0.040	–	127	KOhm	–	5.6

Package Information

4 Package Information

For passivation the sensor is covered with a transparent gel.

4.1 PG-DSOF-8-162 Outline

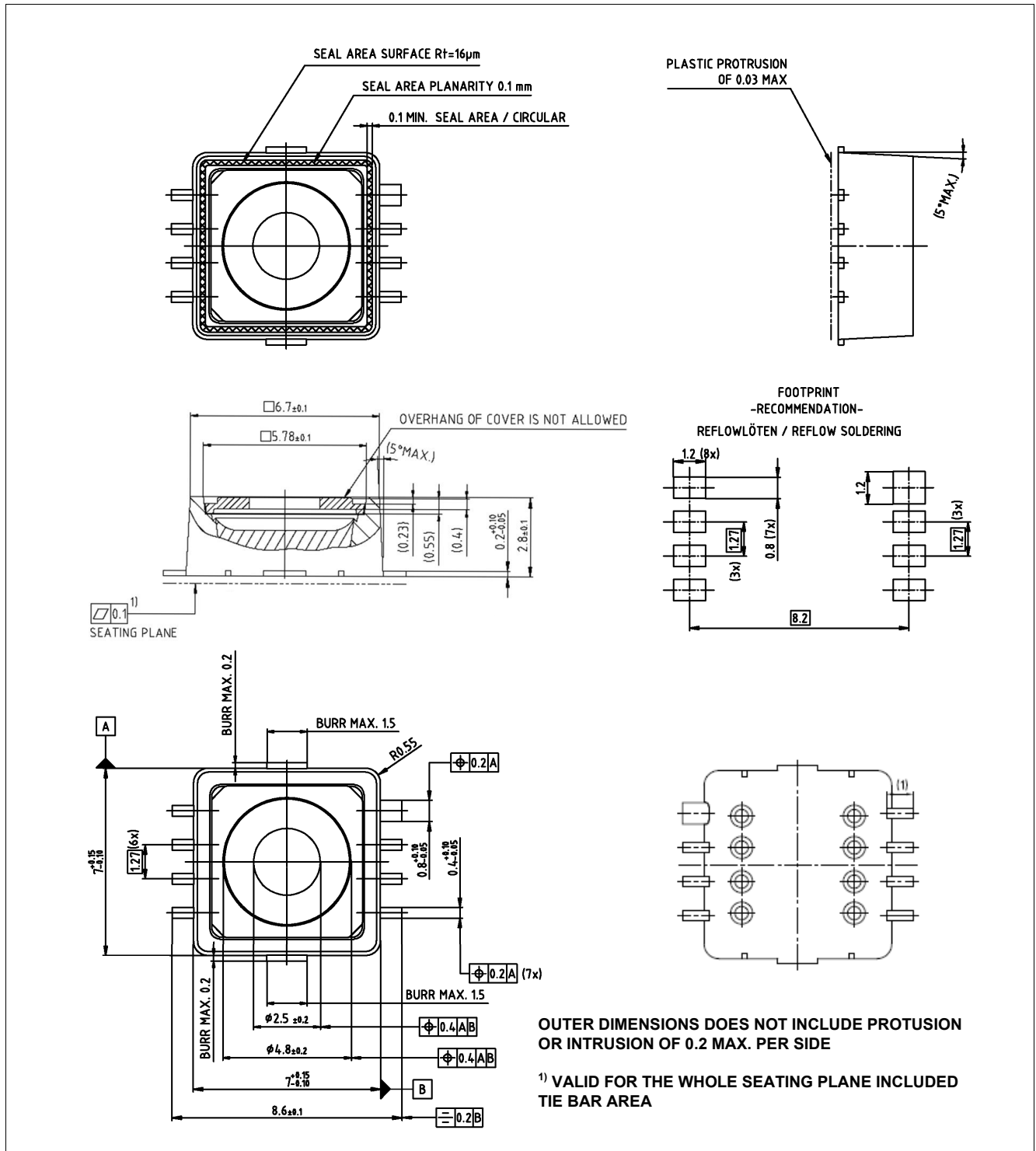

Figure 18 Package outline

Package Information

Green Product (RoHS compliant)

To meet the world-wide customer requirements for environmentally friendly products and to be compliant with government regulations the device is available as a green product. Green products are RoHS-Compliant (i.e Pb-free finish on leads and suitable for Pb-free soldering according to IPC/JEDEC J-STD-020).

4.2 Identification Code

The identification code is provided in a machine readable format. The date and sales code are provided in human readable format.

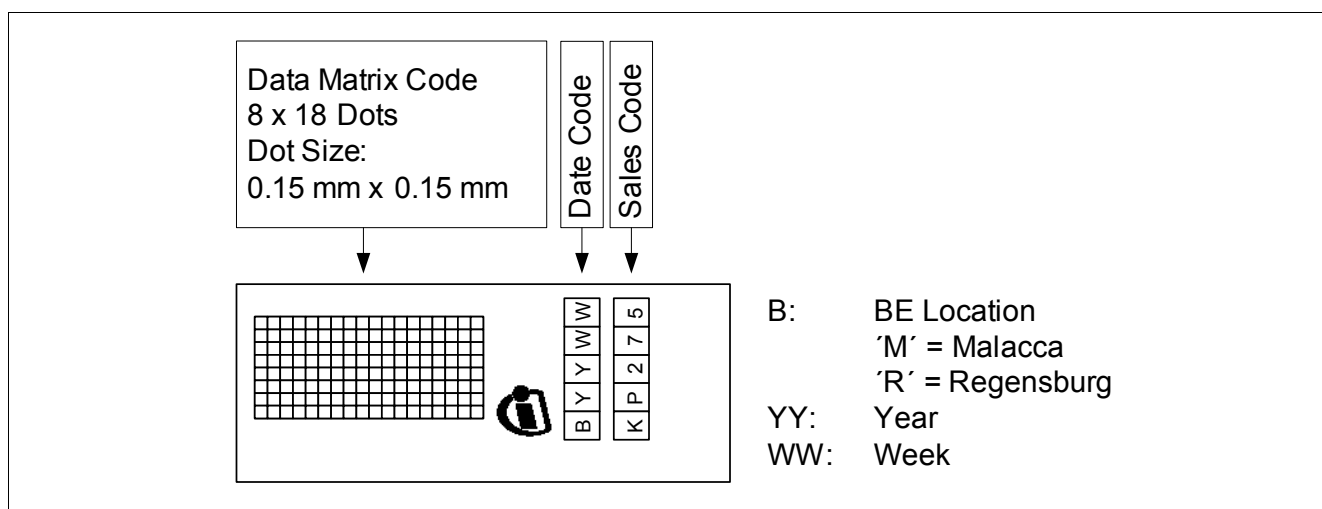

Figure 19 Identification Code

The identification code for the KP275 is on the same side of the package as pin 8 (GND).



Revision History

5 Revision History

Revision History

Page or Item	Subjects (major changes since previous revision)
Revision 1.0, 2016-06-20	
	change document status from target to final

Trademarks of Infineon Technologies AG

AURIX™, C166™, CanPAK™, CIPOS™, CIPURSE™, CoolMOS™, CoolSET™, CORECONTROL™, CROSSAVE™, DAVE™, DI-POL™, EasyPIM™, EconoBRIDGE™, EconoDUAL™, EconoPIM™, EconoPACK™, EiceDRIVER™, eupec™, FCOS™, HITFET™, HybridPACK™, I²RF™, ISOFACE™, IsoPACK™, MIPAQ™, ModSTACK™, my-d™, NovalithIC™, OptimOS™, ORIGA™, POWERCODE™, PRIMARION™, PrimePACK™, PrimeSTACK™, PRO-SIL™, PROFET™, RASIC™, ReverSave™, SatRIC™, SIEGET™, SINDRION™, SIPMOS™, SmartLEWIS™, SPOC™, SOLID FLASH™, TEMPFET™, thinQ!™, TRENCHSTOP™, TriCore™.

Other Trademarks

Advance Design System™ (ADS) of Agilent Technologies, AMBA™, ARM™, MULTI-ICE™, KEIL™, PRIMECELL™, REALVIEW™, THUMB™, µVision™ of ARM Limited, UK. AUTOSAR™ is licensed by AUTOSAR development partnership. Bluetooth™ of Bluetooth SIG Inc. CAT-iq™ of DECT Forum. COLOSSUS™, FirstGPS™ of Trimble Navigation Ltd. EMV™ of EMVCo, LLC (Visa Holdings Inc.). EPCOS™ of Epcos AG. FLEXGO™ of Microsoft Corporation. FlexRay™ is licensed by FlexRay Consortium. HYPERTERMINAL™ of Hilgraeve Incorporated. IEC™ of Commission Electrotechnique Internationale. IrDA™ of Infrared Data Association Corporation. ISO™ of INTERNATIONAL ORGANIZATION FOR STANDARDIZATION. MATLAB™ of MathWorks, Inc. MAXIM™ of Maxim Integrated Products, Inc. MICROTEC™, NUCLEUS™ of Mentor Graphics Corporation. MIPI™ of MIPI Alliance, Inc. MIPS™ of MIPS Technologies, Inc., USA. muRata™ of MURATA MANUFACTURING CO., MICROWAVE OFFICE™ (MWO) of Applied Wave Research Inc., OmniVision™ of OmniVision Technologies, Inc. Openwave™ Openwave Systems Inc. RED HAT™ Red Hat, Inc. RFMD™ RF Micro Devices, Inc. SIRIUS™ of Sirius Satellite Radio Inc. SOLARIS™ of Sun Microsystems, Inc. SPANSION™ of Spansion LLC Ltd. Symbian™ of Symbian Software Limited. TAIYO YUDEN™ of Taiyo Yuden Co. TEAKLITE™ of CEVA, Inc. TEKTRONIX™ of Tektronix Inc. TOKO™ of TOKO KABUSHIKI KAISHA TA. UNIX™ of X/Open Company Limited. VERILOG™, PALLADIUM™ of Cadence Design Systems, Inc. VLYNQ™ of Texas Instruments Incorporated. VXWORKS™, WIND RIVER™ of WIND RIVER SYSTEMS, INC. ZETEX™ of Diodes Zetex Limited.

Last Trademarks Update 2011-11-11

www.infineon.com

Edition 2016-06-20

Published by

Infineon Technologies AG

81726 Munich, Germany

© 2014 Infineon Technologies AG.

All Rights Reserved.

Do you have a question about any aspect of this document?

Email: erratum@infineon.com

Document reference

Legal Disclaimer

The information given in this document shall in no event be regarded as a guarantee of conditions or characteristics. With respect to any examples or hints given herein, any typical values stated herein and/or any information regarding the application of the device, Infineon Technologies hereby disclaims any and all warranties and liabilities of any kind, including without limitation, warranties of non-infringement of intellectual property rights of any third party.

Information

For further information on technology, delivery terms and conditions and prices, please contact the nearest Infineon Technologies Office (www.infineon.com).

Warnings

Due to technical requirements, components may contain dangerous substances. For information on the types in question, please contact the nearest Infineon Technologies Office. Infineon Technologies components may be used in life-support devices or systems only with the express written approval of Infineon Technologies, if a failure of such components can reasonably be expected to cause the failure of that life-support device or system or to affect the safety or effectiveness of that device or system. Life support devices or systems are intended to be implanted in the human body or to support and/or maintain and sustain and/or protect human life. If they fail, it is reasonable to assume that the health of the user or other persons may be endangered.