

**Silicon N-Channel MOSFET**

**Features**

- 11A,900V,  $R_{DS(on)}$ (Max1.10 $\Omega$ )@ $V_{GS}=10V$
- Ultra-low Gate charge(Typical 72nC)
- Fast Switching Capability
- 100%Avalanche Tested
- Maximum Junction Temperature Range(150 $^{\circ}C$ )

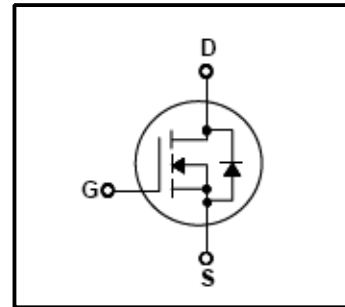

**General Description**

This N-Channel enhancement mode power field effect transistors are produced using Winsemi's proprietary, planar stripe ,DMOS technology. This advanced technology has been especially tailored to minimize on-state resistance , provide superior switching performance, and withstand high energy pulse in the avalanche and commutation mode. These devices are well suited for high efficiency switch mode power supplies.

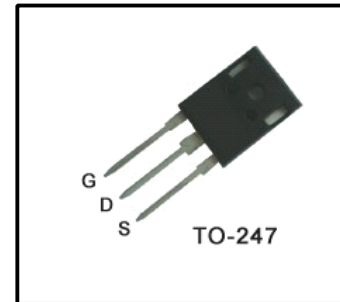

**Absolute Maximum Ratings**

Symbol	Parameter	Value	Units
$V_{DSS}$	Drain Source Voltage	900	V
$I_D$	Continuous Drain Current(@ $T_c=25^{\circ}C$ )	11	A
	Continuous Drain Current(@ $T_c=100^{\circ}C$ )	7	A
$I_{DM}$	Drain Current Pulsed (Note1)	45.6	A
$V_{GS}$	Gate to Source Voltage	$\pm 30$	V
$E_{AS}$	Single Pulsed Avalanche Energy (Note2)	1000	mJ
$E_{AR}$	Repetitive Avalanche Energy (Note1)	30	mJ
dv/dt	Peak Diode Recovery dv /dt (Note3)	4.0	V/ ns
$P_D$	Total Power Dissipation(@ $T_c=25^{\circ}C$ )	300	W
	Derating Factor above 25 $^{\circ}C$	2.38	W/ $^{\circ}C$
$T_J, T_{stg}$	Junction and Storage Temperature	-55~150	$^{\circ}C$
$T_L$	Channel Temperature	300	$^{\circ}C$

**Thermal Characteristics**

Symbol	Parameter	Value			Units
		Min	Typ	Max	
$R_{QJC}$	Thermal Resistance , Junction -to -Case	-	-	0.42	$^{\circ}C/W$
$R_{QCS}$	Thermal Resistance ,Case-to-Sink	-	0.24	-	$^{\circ}C/W$
$R_{QJA}$	Thermal Resistance , Junction-to -Ambient	-	-	40	$^{\circ}C/W$

**Electrical Characteristics(Tc=25 °C)**

Characteristics		Symbol	Test Condition	Min	Type	Max	Unit
Gate leakage current		I <sub>GSS</sub>	V <sub>GS</sub> =±30V,V <sub>DS</sub> =0V	-	-	±100	nA
Gate-source breakdown voltage		V <sub>(BR)GSS</sub>	I <sub>G</sub> =±10 μA,V <sub>DS</sub> =0V	±30	-	-	V
Drain cut -off current		I <sub>DSS</sub>	V <sub>DS</sub> =900V,V <sub>GS</sub> =0V	-	-	10	μA
			V <sub>DS</sub> =720V,Tc=125 °C			100	μA
Drain -source breakdown voltage		V <sub>(BR)DSS</sub>	I <sub>D</sub> =250μA,V <sub>GS</sub> =0V	900	-	-	V
Gate threshold voltage		V <sub>GS(th)</sub>	V <sub>DS</sub> =V <sub>GS</sub> ,I <sub>D</sub> =250μA	3.0	-	5.0	V
Drain -source ON resistance		R <sub>DS(ON)</sub>	V <sub>GS</sub> =10V,I <sub>D</sub> =5.5A	-	0.95	1.10	Ω
Forward Transconductance		g <sub>fs</sub>	V <sub>DS</sub> =50V,I <sub>D</sub> =5.5A	-	12	-	S
Input capacitance		C <sub>iss</sub>	V <sub>DS</sub> =25V,	-	2700	3500	pF
Reverse transfer capacitance		C <sub>rss</sub>	V <sub>GS</sub> =0V,	-	30	40	
Output capacitance		C <sub>oss</sub>	f=1MHz	-	260	340	
Switching time	Turn-on Rise time	t <sub>r</sub>	V <sub>DD</sub> =450V, I <sub>D</sub> =11A R <sub>G</sub> =25Ω (Note4,5)	-	135	280	ns
	Turn-on Delay time	t <sub>d(on)</sub>		-	65	140	
	Turn-on Fall time	t <sub>f</sub>		-	90	190	
	Turn-off Delay time	t <sub>d(off)</sub>		-	165	340	
Total gate charge(gate-source plus gate-drain)		Q <sub>g</sub>	V <sub>DD</sub> =720V, V <sub>GS</sub> =10V, I <sub>D</sub> =11A (Note4,5)	-	72	94	nC
Gate-source charge		Q <sub>gs</sub>		-	16	-	
Gate-drain("miller") Charge		Q <sub>gd</sub>		-	35	-	

**Source-Drain Ratings and Characteristics(Ta=25 °C)**

Characteristics	Symbol	Test Condition	Min	Type	Max	Unit
Continuous drain reverse current	I <sub>DR</sub>	-	-	-	11	A
Pulse drain reverse current	I <sub>DRP</sub>	-	-	-	45	A
Forward voltage(diode)	V <sub>DSF</sub>	I <sub>DR</sub> =11A,V <sub>GS</sub> =0V	-	-	1.4	V
Reverse recovery time	t <sub>rr</sub>	I <sub>DR</sub> =11A,V <sub>GS</sub> =0V,	-	850	-	ns
Reverse recovery charge	Q <sub>rr</sub>	dI <sub>DR</sub> / dt =100 A / μs	-	11.2	-	μC

Note 1.Repeativity rating :pulse width limited by junction temperature

2.L=15mH I<sub>AS</sub>=11A,V<sub>DD</sub>=50V,R<sub>G</sub>=25Ω,Starting T<sub>J</sub>=25 °C

3.I<sub>SD</sub>≤11A,di/dt≤200A/us,V<sub>DD</sub><BV<sub>DSS</sub>,STARTING T<sub>J</sub>=25 °C

4.Pulse Test:Pulse Width≤300us,Duty Cycle≤2%

5. Essentially independent of operating temperature.

This transistor is an electrostatic sensitive device

Please handle with caution

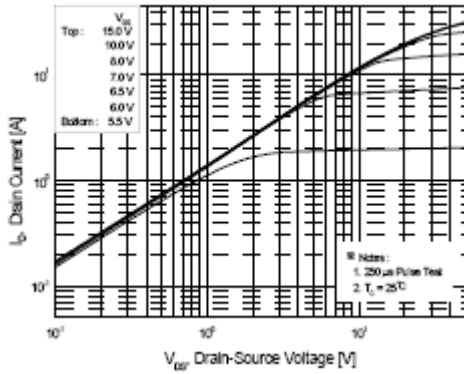

**Fig.1 On State Characteristics**

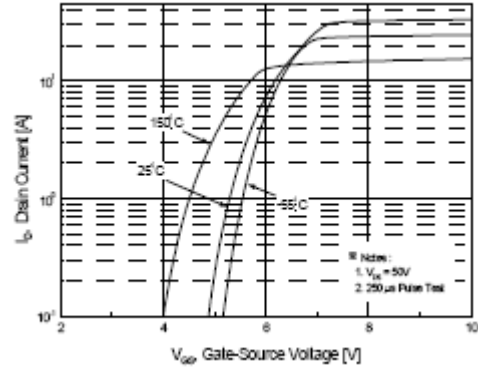

**Fig.2 Transfer Current Characteristics**

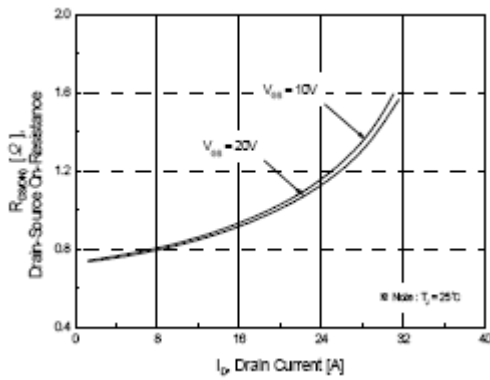

**Fig.3 On-Resistance Variation vs Drain current and Gate Voltage**

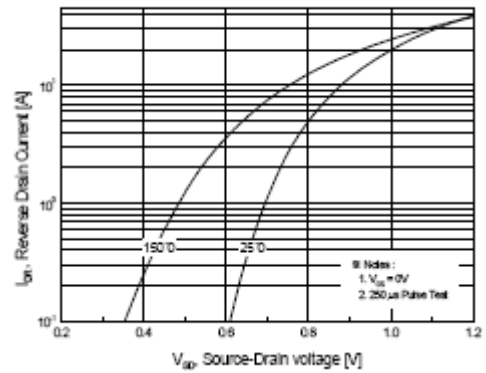

**Fig.4 Body Diode Forward voltage Variation with Source Current And Temperature**

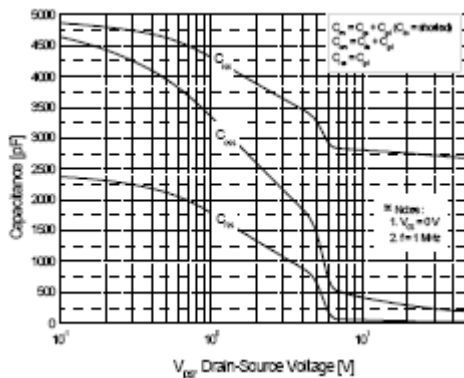

**Fig.5 Capacitance Characteristics**

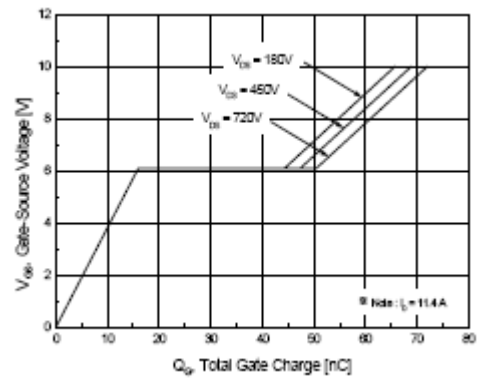

**Fig.6 Gate Charge Characteristics**

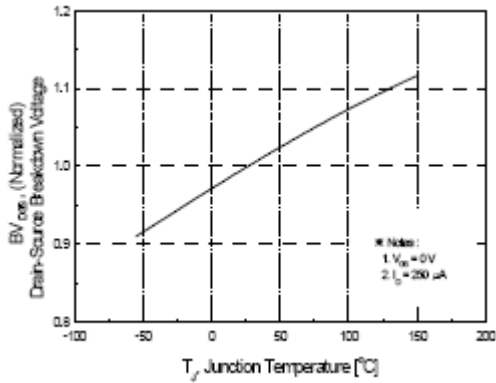

**Fig.7 Breakdown Voltage Variation vs. Temperature**

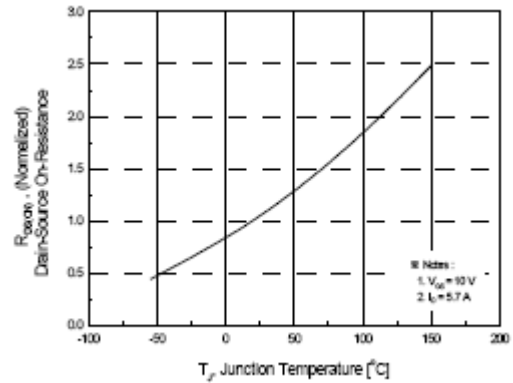

**Fig.8 On-Resistance Variation vs. Temperature**

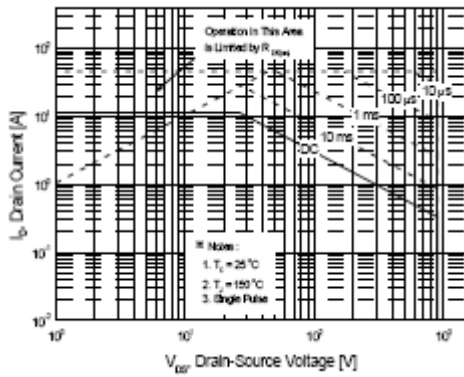

**Fig.9 Maximum Safe Operation Area**

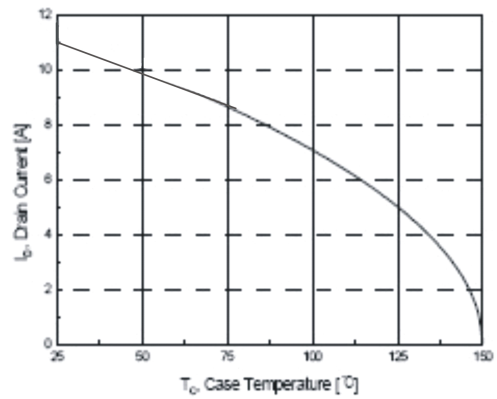

**Fig.10 Maximum Drain Current vs Case temperature**

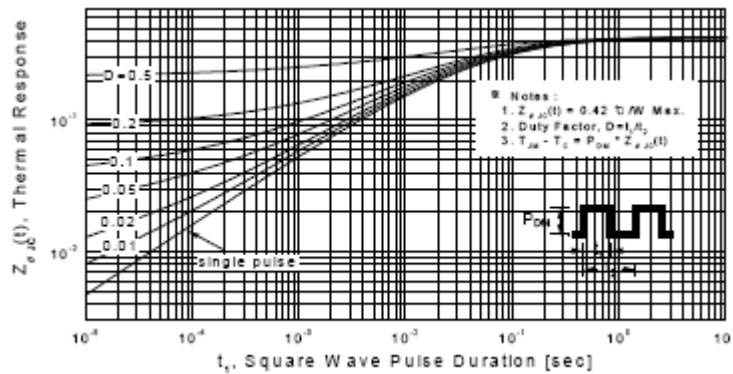

**Fig.11 Transient thermal Response Curve**

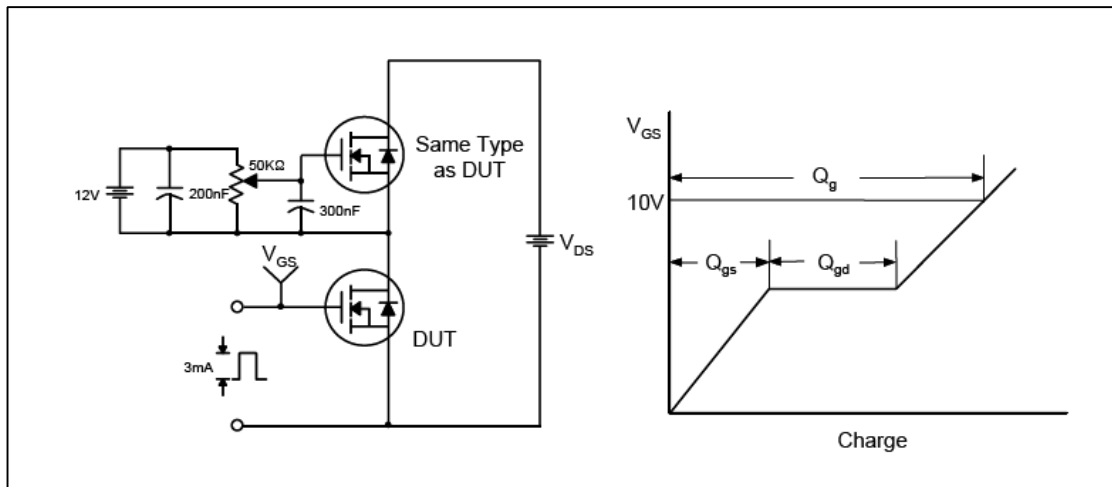

**Fig.12 Gate Test circuit & Waveform**

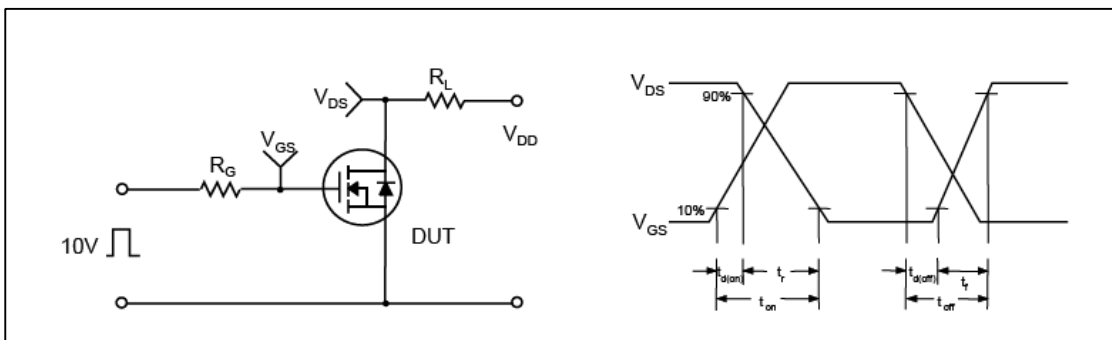

**Fig.13 Resistive Switching Test Circuit & Waveform**

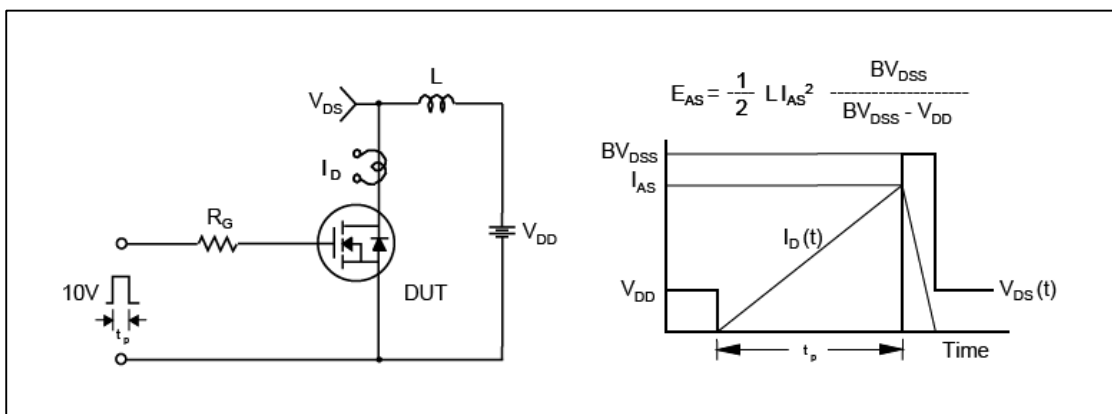

**Fig.14 Unclamped Inductive Switching Test Circuit & Waveform**

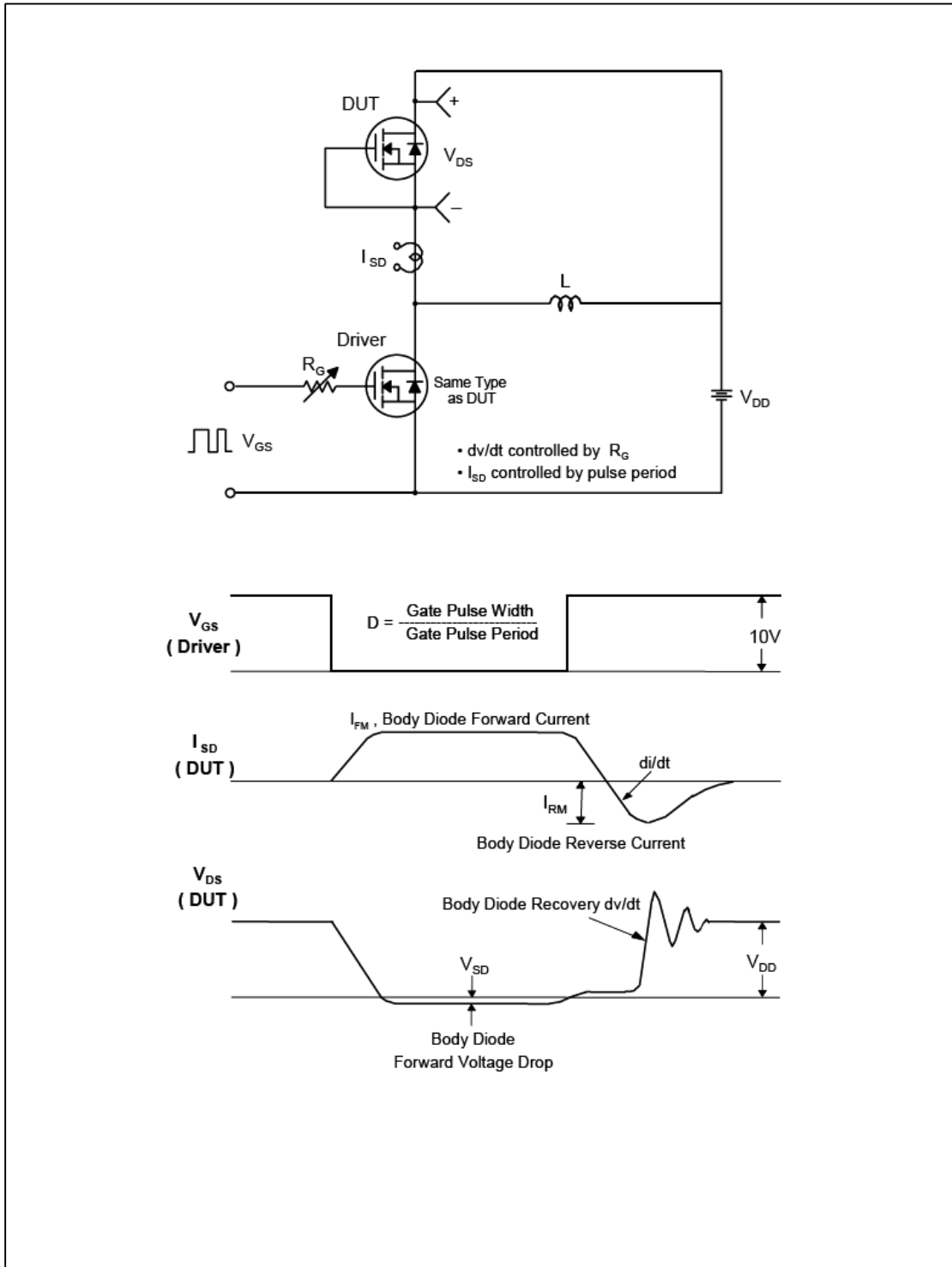

**Fig.15 Peak Diode Recovery  $dv/dt$  Test Circuit & Waveform**

**TO-247 Package Dimension**

