



High Performance Sensorless Motor Control IC

Description

IRMCF171 is a high performance flash memory based motion control IC designed primarily for appliance applications. IRMCF171 is designed to achieve low cost yet high performance control solutions for advanced inverterized appliance motor control. IRMCF171 contains two computation engines integrated into one monolithic chip. One is the Flexible Motion Control Engine (MCE™) for sensorless control of permanent magnet or induction motors; the other is an 8-bit high-speed microcontroller (8051). The user can program a motion control algorithm by connecting control elements using a graphic compiler. Key components of the complex sensorless control algorithms, such as the Angle Estimator, are provided as complete pre-defined control blocks. A unique analog/digital circuit and algorithm fully supports single or leg shunt current reconstruction. The MCE and 8051 microcontroller communicate via dual port RAM for signal monitoring and command input. An advanced graphic compiler for the MCE™ is seamlessly integrated into the MATLAB/Simulink environment, while third party JTAG-based emulator tools are supported for 8051 software development including a flash programmer. IRMCF171 comes in a 48 pin QFP package.

Features

- MCE™ (Flexible Motion Control Engine) - Dedicated computation engine for high efficiency sinusoidal sensorless motor control
- Built-in hardware peripheral for single or two shunt current feedback reconstruction and analog circuits
- Supports induction machine and both interior and surface permanent magnet motor sensorless control
- Loss minimization Space Vector PWM
- Two-channel analog output (PWM)
- Embedded 8-bit high speed microcontroller (8051) for flexible I/O and man-machine control
- JTAG programming port for emulation/debugger
- Serial communication interface (UART)
- I2C/SPI serial interface
- Three general purpose timers/counters
- Two special timers: periodic timer, capture timer
- Watchdog timer with independent internal clock
- Internal 64 Kbyte flash memory
- 5V tolerant I/O
- 3.3V single supply

Product Summary

Maximum clock input ($f_{crystal}$)	60 MHz
Maximum Internal clock (SYSCLK)	120MHz
Maximum 8051 clock (8051CLK)	30MHz
Sensorless control computation time	35 μ sec@100MHz
MCE™ computation data range	16 bit signed
8051 Program Flash	52KB
805/MCE Data RAM	4KB
MCE Program RAM	12KB
GateKill latency (digital filtered)	2 μ sec
PWM carrier frequency	20 bits/ SYSCLK
A/D input channels	7
A/D converter resolution	12 bits
A/D converter conversion speed	2 μ sec
Analog output (PWM) resolution	8 bits
UART baud rate (typ)	57.6K bps
Number of digital I/O (max)	14
Package (lead free)	QFP48
Typical 3.3V operating current	30mA

Base Part Number	Package Type	Standard Pack		Orderable Part Number
		Form	Quantity	
IRMCF171	LQFP48	Tape and Reel	2000	IRMCF171TR
IRMCF171	LQFP48	Tray	2500	IRMCF171TY

Table of Contents

1	Overview.....	5
2	Pinout	6
3	IRMCF171 Block Diagram and Main Functions	7
4	Application connection and Pin function	9
4.1	8051 Peripheral Interface Group.....	10
4.2	Motion Peripheral Interface Group.....	11
4.3	Analog Interface Group.....	11
4.4	Power Interface Group.....	12
4.5	Test Interface Group.....	12
5	DC Characteristics.....	13
5.1	Absolute Maximum Ratings	13
5.2	System Clock Frequency and Power Consumption.....	13
5.3	Digital I/O DC Characteristics	14
5.4	PLL and Oscillator DC characteristics	15
5.5	Analog I/O DC Characteristics.....	15
5.6	Under Voltage Lockout DC characteristics	16
5.7	Itrip comparator DC characteristics.....	16
5.8	CNEXT and AREF Characteristics	16
6	AC Characteristics	17
6.1	Digital PLL AC Characteristics.....	17
6.2	Analog to Digital Converter AC Characteristics	18
6.3	Op amp AC Characteristics	19
6.4	SYNC to SVPWM and A/D Conversion AC Timing.....	20
6.5	GATEKILL to SVPWM AC Timing	21
6.6	Itrip AC Timing.....	21
6.7	Interrupt AC Timing.....	22
6.8	I ² C AC Timing	23
6.9	SPI AC Timing	24
	SPI Write AC timing	24
	SPI Read AC Timing.....	25
6.10	UART AC Timing	26
6.11	CAPTURE Input AC Timing.....	27
6.12	JTAG AC Timing.....	28
7	I/O Structure	29
8	Pin List.....	32
9	Package Dimensions	34
10	Part Marking Information	35
11	Qualification Information <i>f</i>	35

List of Tables

Table 2. Absolute Maximum Ratings	13
Table 3. System Clock Frequency	13
Table 4. Digital I/O DC Characteristics	14
Table 5 PLL DC Characteristics	15
Table 6. Analog I/O DC Characteristics	15
Table 7. UVcc DC Characteristics	16
Table 8. Itrip DC Characteristics	16
Table 9. CMEXT and AREF DC Characteristics	16
Table 10. PLL AC Characteristics	17
Table 11 . A/D Converter AC Characteristics	18
Table 12 Current Sensing OP Amp AC Characteristics	19
Table 13. SYNC AC Characteristics	20
Table 14. GATEKILL to SVPWM AC Timing	21
Table 15. Itrip AC Timing	21
Table 16. Interrupt AC Timing	22
Table 17. I ² C AC Timing	23
Table 18. SPI Write AC Timing	24
Table 19. SPI Read AC Timing	25
Table 20. UART AC Timing	26
Table 21. CAPTURE AC Timing	27
Table 22. JTAG AC Timing	28
Table 23. Pin List	33

List of Figures

Figure 1. Typical Application Block Diagram Using IRMCF171	5
Figure 2. Pinout of IRMCF171	6
Figure 3. IRMCF171 Block Diagram	7
Figure 4. IRMCF171 Leg Shunt Connection Diagram	9
Figure 5. IRMCF171 Single Shunt Connection Diagram	10
Figure 6. Crystal circuit example	17
Figure 7. Voltage droop and S/H hold time	18
Figure 8 Op amp output capacitor	19
Figure 9. SYNC timing	20
Figure 10. Gatekill timing	21
Figure 11. ITRIP timing	21
Figure 12. Interrupt timing	22
Figure 13. I ² C Timing	23
Figure 14. SPI write timing	24
Figure 15. SPI read timing	25
Figure 16. UART timing	26
Figure 17. CAPTURE timing	27
Figure 18. JTAG timing	28
Figure 19. PWMUL/PWMUH/PWMVL/PWMVH/PWMWL/PWMWH output	29
Figure 20. All digital I/O except motor PWM output	29
Figure 21. RESET, GATEKILL I/O	29
Figure 22. Analog input	30
Figure 24 Analog operational amplifier output and AREF I/O structure	30
Figure 25. VSS,AVSS pin I/O structure	30
Figure 26. VDD1,VDDCAP pin I/O structure	31
Figure 27. XTAL0/XTAL1 pins structure	31

1 Overview

IRMCF171 is a new generation International Rectifier integrated circuit device primarily designed as a one-chip solution for complete inverterized appliance motor control applications. Unlike a traditional microcontroller or DSP, the IRMCF171 provides a built-in closed loop sensorless control algorithm using the unique flexible Motion Control Engine (MCETM) for permanent magnet motors as well as induction motors. The MCE™ consists of a collection of control elements, motion peripherals, a dedicated motion control sequencer and dual port RAM to map internal signal nodes. IRMCF171 also employs a unique single shunt current reconstruction circuit in addition to two leg shunt current sensing circuit to eliminate additional analog/digital circuitry and enables a direct shunt resistor interface to the IC. Motion control programming is achieved using a dedicated graphical compiler integrated into the MATLAB/Simulink™ development environment. Sequencing, user interface, host communication, and upper layer control tasks can be implemented in the 8051 high-speed 8-bit microcontroller. The 8051 microcontroller is equipped with a JTAG port to facilitate emulation and debugging tools. Figure 1 shows a typical application schematic using the IRMCF171.

IRMCF171 contains 64 Kbytes of Flash program memory. The IRMCK171 contains 32 Kbytes OTP memory and is intended for high volume production purposes while the IRMCF171 is intended for flexible volume production. Both the Flash and ROM versions come in a 48-pin QFP package with identical pin configuration to facilitate PC board layout and transition to mass production.

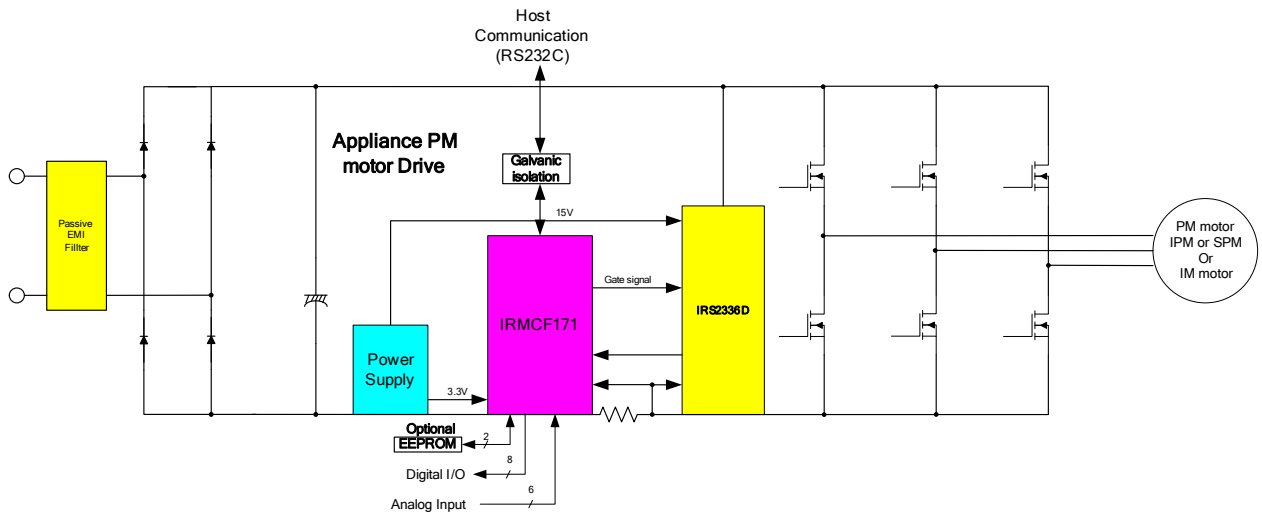

Figure 1. Typical Application Block Diagram Using IRMCF171

2 Pinout

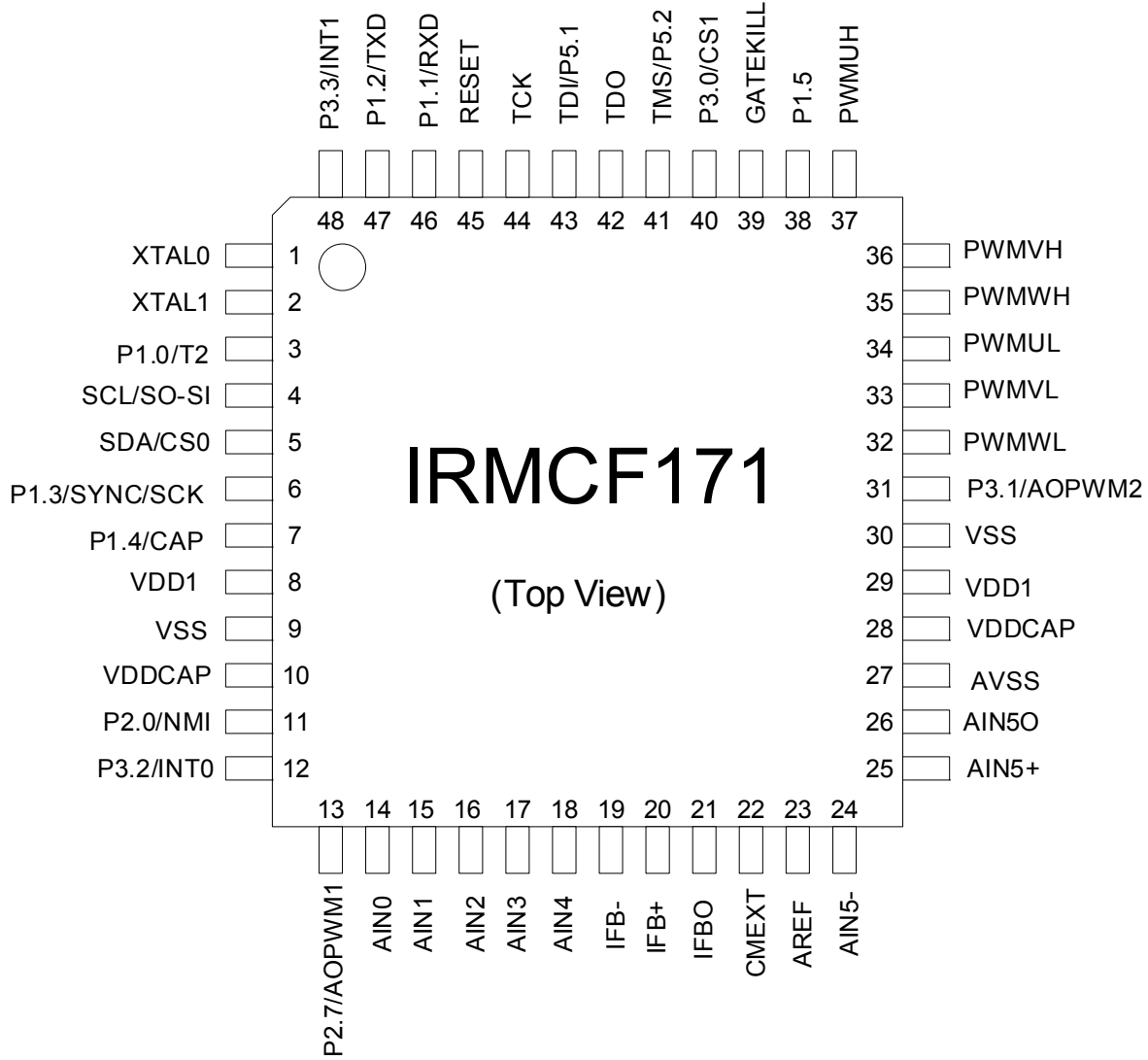

Figure 2. Pinout of IRMCF171

3 IRMCF171 Block Diagram and Main Functions

IRMCF171 block diagram for leg shunt mode is shown in Figure 3.

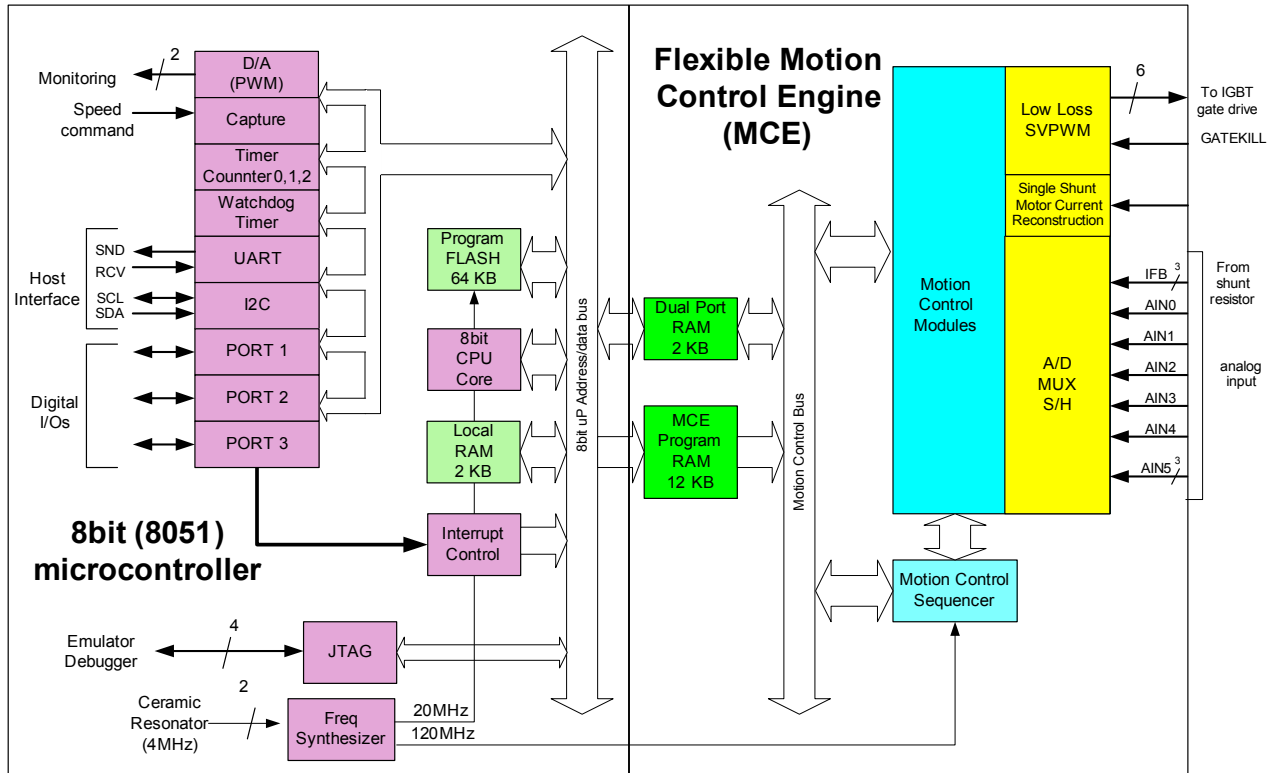

Figure 3. IRMCF171 Block Diagram

IRMCF171 contains the following functions for sensorless AC motor control applications:

Motion Control Engine (MCE™)

- Sensorless FOC (complete sensorless field oriented control)
- Proportional plus Integral block
- Low pass filter
- Differentiator and lag (high pass filter)
- Ramp
- Limit
- Angle estimate (sensorless control)
- Inverse Clark transformation
- Vector rotator
- Bit latch
- Peak detect
- Transition
- Multiply-divide (signed and unsigned)
- Adder
- Divide (signed and unsigned)

8051 microcontroller

- Two 16 bit timer/counters
- One 16 bit periodic timer
- One 16 bit watchdog timer
- One 16 bit capture timer
- Up to 14 discrete digital I/Os
- Seven-channel 12 bit A/D
 - Buffered (current sensing) two channels (0 – 1.2V input)
 - Unbuffered five channels (0 – 1.2V input)
- JTAG port (4 pins)
- Up to two channels of analog output (8 bit PWM)
- UART
- I²C/SPI port
- 2K byte data RAM

- Subtractor
 - Comparator
 - Counter
 - Accumulator
 - Switch
 - Shift
 - ATAN (arc tangent)
 - Function block (any curve fitting, nonlinear function)
 - 16 bit wide Logic operations (AND, OR, XOR, NOT, NEGATE)
 - MCE™ program memory and dual port RAM (6K byte)
 - MCE™ control sequencer
- 64K byte Flash memory

4 Application connection and Pin function

Figure 4 shows the application connections in leg shunt mode. Figure 5 shows the application connections in single shunt mode.

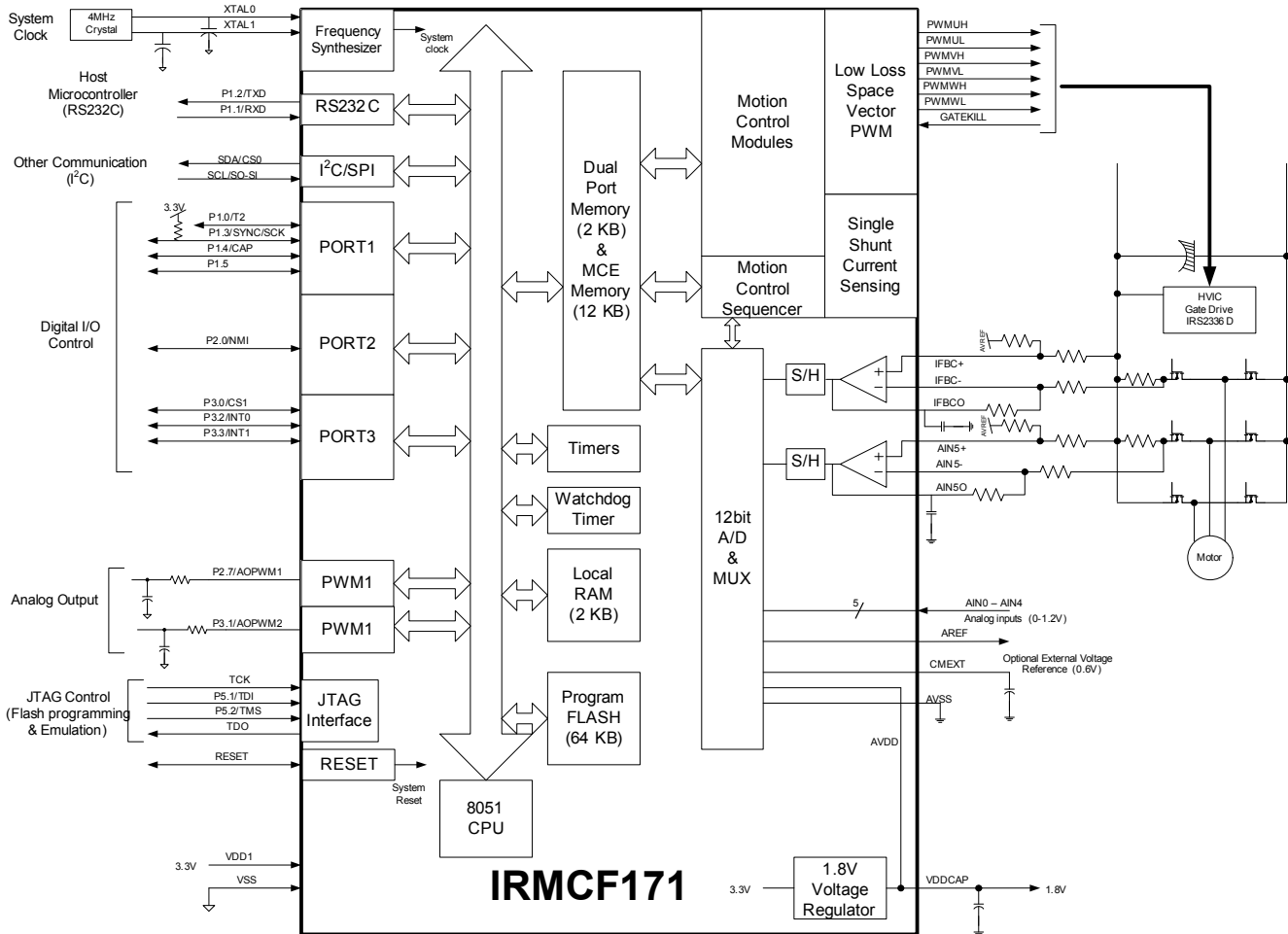

Figure 4. IRMCF171 Leg Shunt Connection Diagram

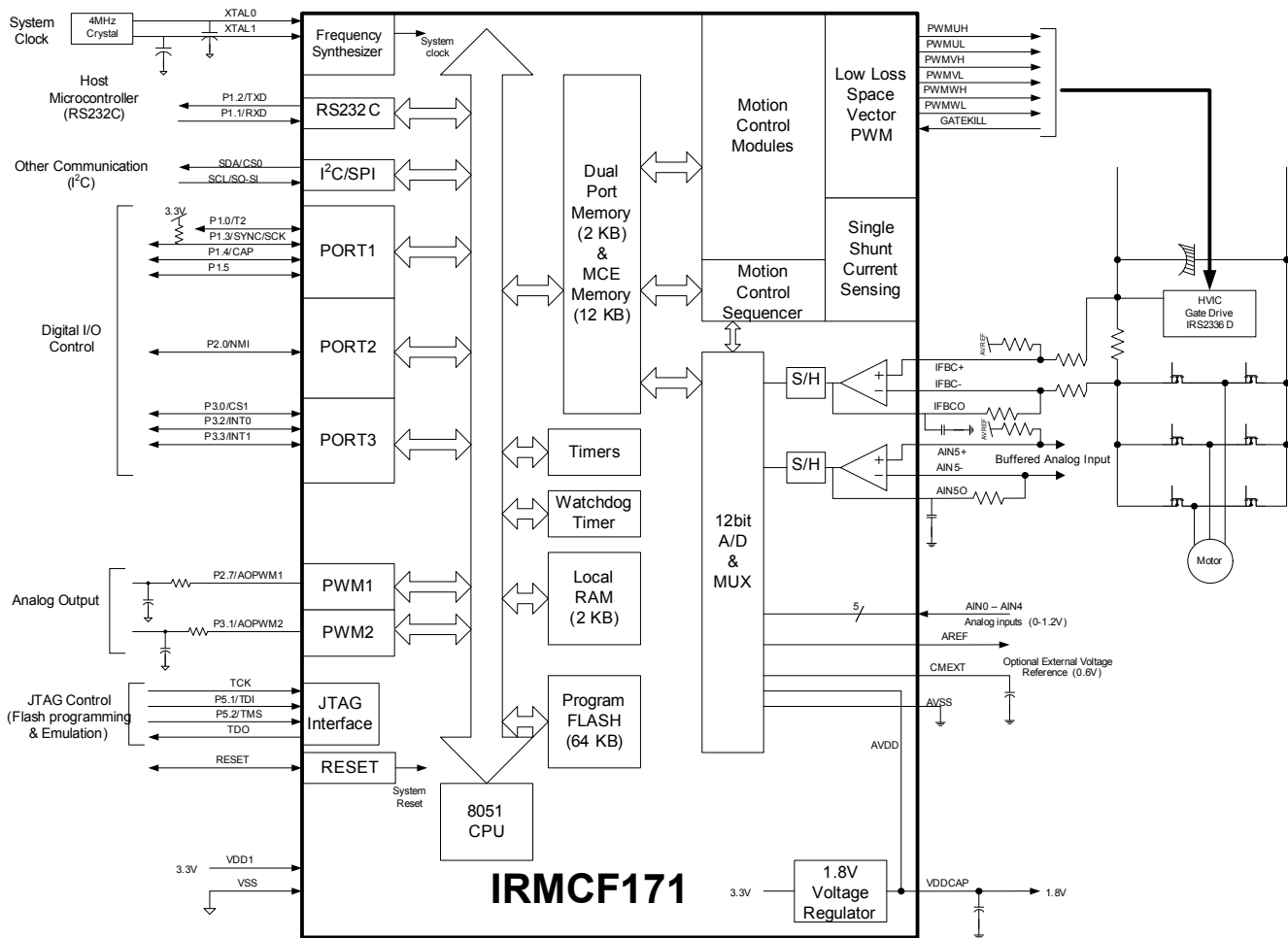

Figure 5. IRMCF171 Single Shunt Connection Diagram

4.1 8051 Peripheral Interface Group

UART Interface

P1.2/TXD Output, Transmit data from IRMCF171
 P1.1/RXD Input, Receive data to IRMCF171

Discrete I/O Interface

P1.0/T2 Input/output port 1.0, can be configured as Timer/Counter 2 input
 P1.1/RXD Input/output port 1.1, can be configured as RXD input
 P1.2/TXD Input/output port 1.2, can be configured as TXD output
 P1.3/SYNC/SCK Input/output port 1.3, can be configured as SYNC output or SPI clock output
 P1.4/CAP Input/output port 1.4, can be configured as Capture Timer input
 P1.5 Input/output port 1.5
 P2.0/NMI Input/output port 2.0, can be configured as non-maskable interrupt input
 P2.7/AOPWM1 Input/output port 2.7, can be configured as AOPWM1 output
 P3.0/INT2/CS1 Input/output port 3.0, can be configured as INT2 input or SPI chip select 1
 P3.1/AOPWM2 Input/output port 3.1, can be configured as AOPWM2 output
 P3.2/INT0 Input/output port 3.2, can be configured as INT0 input
 P3.3/INT1 Input/output port 3.3, can be configured as INT1 input
 P5.1/TDI Input port 5.1, configured as JTAG port by default

P5.2/TMS Input port 5.2, configured as JTAG port by default

Analog Output Interface

P2.7/AOPWM1 Input/output, can be configured as 8-bit PWM output 1 with programmable carrier frequency
 P3.1/AOPWM2 Input/output, can be configured as 8-bit PWM output 2 with programmable carrier frequency

Crystal Interface

XTAL0 Input, connected to crystal
 XTAL1 Output, connected to crystal

Reset Interface

RESET Input and Output, system reset, doesn't require external RC time constant

I²C Interface

SCL/SO-SI Output, I²C clock output, or SPI data
 SDA/CS0 Input/output, I²C Data line or SPI chip select 0

I²C/SPI Interface

SCL/SO-SI Output, I²C clock output, or SPI data
 SDA/CS0 Input/output, I²C data line or SPI chip select 0
 P1.3/SYNC/SCK Input/output port 1.3, can be configured as SYNC output or SPI clock output
 P3.0/INT2/CS1 Input/output port 3.0, can be configured as INT2 input or SPI chip select 1

4.2 Motion Peripheral Interface Group

PWM

PWMUH Output, PWM phase U high side gate signal, internally pulled down by 58kΩ, configured high true at a power up
 PWMUL Output, PWM phase U low side gate signal, internally pulled down by 58kΩ, configured high true at a power up
 PWMVH Output, PWM phase V high side gate signal, internally pulled down by 58kΩ, configured high true at a power up
 PWMVL Output, PWM phase V low side gate signal, internally pulled down by 58kΩ, configured high true at a power up
 PWMWH Output, PWM phase W high side gate signal, internally pulled down by 58kΩ, configured high true at a power up
 PWMWL Output, PWM phase W low side gate signal, internally pulled down by 58kΩ, configured high true at a power up
 PFCPWM Output, PFCPWM output signal, internally pulled up by 70kΩ, configured low true at a power up

Fault

GATEKILL Input, upon assertion this negates all six PWM signals, active low, internally pulled up by 70kΩ

4.3 Analog Interface Group

AVSS Analog power return, (analog internal 1.8V power is shared with VDDCAP)
 AREF 0.6V buffered output
 CMEXT Unbuffered 0.6V, input to the AREF buffer, capacitor needs to be connected.
 IFB+ Input, Operational amplifier positive input for shunt resistor current sensing

IFB- IFBO	Input, Operational amplifier negative input for shunt resistor current sensing Output, Operational amplifier output for shunt resistor current sensing
AIN0	Input, Analog input channel 0 (0 – 1.2 V), typically configured for DC bus voltage input
AIN1	Input, Analog input channel 1 (0 – 1.2 V), needs to be pulled down to AVSS if unused
AIN2	Input, Analog input channel 2 (0 – 1.2 V), needs to be pulled down to AVSS if unused
AIN3	Input, Analog input channel 3 (0 – 1.2 V), needs to be pulled down to AVSS if unused
AIN4	Input, Analog input channel 4 (0 – 1.2 V), needs to be pulled down to AVSS if unused
AIN5+	Input, Operational amplifier positive input for shunt resistor current sensing
AIN5-	Input, Operational amplifier negative input for shunt resistor current sensing
AIN5O	Output, Operational amplifier output for AIN5 output, there is a single sample/hold circuit on the output

4.4 Power Interface Group

VDD1	Digital power (3.3V)
VDDCAP	Internal 1.8V output, requires capacitors to the pin. Shared with analog power pad internally Note: The internal 1.8V supply is not designed to power any external circuits or devices. Only capacitors should be connected to this pin.
VSS	Digital common

4.5 Test Interface Group

P5.2/TMS	JTAG test mode input or input digital port
TDO	JTAG data output
P5.1/TDI	JTAG data input, or input digital port
TCK	JTAG test clock

5 DC Characteristics

5.1 Absolute Maximum Ratings

Symbol	Parameter	Min	Typ	Max	Condition
V _{DD1}	Supply Voltage	-0.3 V	-	3.6 V	Respect to VSS
V _{IA}	Analog Input Voltage	-0.3 V	-	1.98 V	Respect to AVSS
V _{ID}	Digital Input Voltage	-0.3 V	-	6.0 V	Respect to VSS
T _A	Ambient Temperature	-40 °C	-	85 °C	
T _S	Storage Temperature	-65 °C	-	150 °C	

Table 1. Absolute Maximum Ratings

Caution: Stresses beyond those listed in “Absolute Maximum Ratings” may cause permanent damage to the device. These are stress ratings only and function of the device at these or any other conditions beyond those indicated in the operational sections of the specifications are not implied.

5.2 System Clock Frequency and Power Consumption

C_{CAREF} = 1nF, C_{CMEXT} = 100nF. VDD1=3.3V, Unless specified, Ta = 25°C.

Symbol	Parameter	Min	Typ	Max	Unit
SYCLK	System Clock	32	-	120	MHz
P _D	Power consumption		100 ¹⁾	-	mW

Table 2. System Clock Frequency

Note 1) The value is based on the condition of MCE clock=120MHz, 8051 clock 30MHz with a actual motor running by a typical MCE application program and 8051 code.

5.3 Digital I/O DC Characteristics

Symbol	Parameter	Min	Typ	Max	Condition
V_{DD1}	Supply Voltage	3.0 V	3.3 V	3.6 V	Recommended
V_{IL}	Input Low Voltage	-0.3 V	-	0.8 V	Recommended
V_{IH}	Input High Voltage	2.0 V		3.6 V	Recommended
C_{IN}	Input capacitance	-	3.6 pF	-	(1)
I_L	Input leakage current		± 10 nA	± 1 μ A	$V_O = 3.3$ V or 0 V
$I_{OL1}^{(2)}$	Low level output current	8.9 mA	13.2 mA	15.2 mA	$V_{OL} = 0.4$ V (1)
$I_{OH1}^{(2)}$	High level output current	12.4 mA	24.8 mA	38 mA	$V_{OH} = 2.4$ V (1)
$I_{OL2}^{(3)}$	Low level output current	17.9 mA	26.3 mA	33.4 mA	$V_{OL} = 0.4$ V (1)
$I_{OH2}^{(3)}$	High level output current	24.6 mA	49.5 mA	81 mA	$V_{OH} = 2.4$ V (1)

Table 3. Digital I/O DC Characteristics

Note:

- (1) Data guaranteed by design.
- (2) Applied to SCL/SO-SI, SDA/CS0 pins.
- (3) Applied to all digital I/O pins except SCL/SO-SI and SDA/CS0 pins.

5.4 PLL and Oscillator DC characteristics

$C_{AREF} = 1nF$, $C_{MEXT} = 100nF$. $V_{DD1} = 3.3V$, Unless specified, $T_a = 25^\circ C$.

Symbol	Parameter	Min	Typ	Max	Condition
$V_{IL\ OSC}$	Oscillator (XTAL0,1) Input Low Voltage	0	-	$0.2 * V_{DDCAP}$	V_{DDCAP} = voltage at VDDCAP pin
$V_{IH\ OSC}$	Oscillator (XTAL0,1) Input High Voltage	$0.8 * V_{DDCAP}$	-	V_{DDCAP}	V_{DDCAP} = voltage at VDDCAP pin

Table 4 PLL DC Characteristics

5.5 Analog I/O DC Characteristics

- OP amps for current sensing (IFB+, IFB-, IFBO, AIN5+, AIN5-, AIN5O)

$C_{AREF} = 1nF$, $C_{MEXT} = 100nF$. $V_{DD1} = 3.3V$, Unless specified, $T_a = 25^\circ C$.

Symbol	Parameter	Min	Typ	Max	Condition
V_{OFFSET}	Input Offset Voltage	-	-	26 mV	$V_{AVDD} = 1.8 V$
V_I	Input Voltage Range	0 V	-	1.2 V	Recommended
V_{OUTSW}	OP amp output operating range	50 mV ⁽¹⁾	-	1.2 V	$V_{AVDD} = 1.8 V$
C_{IN}	Input capacitance	-	3.6 pF	-	(1)
R_{FDBK}	OP amp feedback resistor	5 k Ω	-	20 k Ω	Requested between IFBO and IFB-
OP $GAIN_{CL}$	Operating Close loop Gain	80 db	-	-	(1)
CMRR	Common Mode Rejection Ratio	-	80 db	-	(1)
I_{SRC}	Op amp output source current	-	1 mA	-	$V_{OUT} = 0.6 V$ ⁽¹⁾
I_{SNK}	Op amp output sink current	-	100 μA	-	$V_{OUT} = 0.6 V$ ⁽¹⁾

Table 5. Analog I/O DC Characteristics

Note:

(1) Data guaranteed by design.

5.6 Under Voltage Lockout DC characteristics

Unless specified, $T_a = 25^\circ\text{C}$.

Symbol	Parameter	Min	Typ	Max	Condition
UV_{CC+}	UVcc positive going Threshold	2.78 V	3.04 V	3.23 V	(1)
UV_{CC-}	UVcc negative going Threshold	2.78 V	2.97 V	3.23 V	
UV_{CCH}	UVcc Hysteresys	-	73 mV	-	(1)

Table 6. UVcc DC Characteristics

Note:

(1) Data guaranteed by design.

5.7 Itrip comparator DC characteristics

Unless specified, $V_{DD1}=3.3\text{V}$, $T_a = 25^\circ\text{C}$.

Symbol	Parameter	Min	Typ	Max	Condition
$Itrip_+$	Itrip positive going Threshold	-	1.22V	-	$V_{DD1} = 3.3\text{ V}$
$Itrip_-$	Itrip negative going Threshold	-	1.10V	-	$V_{DD1} = 3.3\text{ V}$
$ItripH$	Itrip Hysteresys	-	120mV	-	

Table 7. Itrip DC Characteristics

5.8 CMEXT and AREF Characteristics

$C_{AREF} = 1\text{nF}$, $C_{MEXT} = 100\text{nF}$. Unless specified, $T_a = 25^\circ\text{C}$.

Symbol	Parameter	Min	Typ	Max	Condition
V_{CM}	CMEXT voltage	495 mV	600 mV	700 mV	$V_{VDD1} = 3.3\text{ V}$
V_{AREF}	Buffer Output Voltage	495 mV	600 mV	700 mV	$V_{VDD1} = 3.3\text{ V}$
ΔV_o	Load regulation ($V_{DC}-0.6$)	-	1 mV	-	(1)
PSRR	Power Supply Rejection Ratio	-	75 db	-	(1)

Table 8. CMEXT and AREF DC Characteristics

Note:

(1) Data guaranteed by design.

6 AC Characteristics

6.1 Digital PLL AC Characteristics

Symbol	Parameter	Min	Typ	Max	Condition
F _{CLKIN}	Crystal input frequency	3.2 MHz	4 MHz	60 MHz	⁽¹⁾ (see figure below)
F _{PLL}	Internal clock frequency	32 MHz	50 MHz	128 MHz	⁽¹⁾
F _{LWPPW}	Sleep mode output frequency	F _{CLKIN} ÷ 256	-	-	⁽¹⁾
J _S	Short time jitter	-	200 psec	-	⁽¹⁾
D	Duty cycle	-	50 %	-	⁽¹⁾
T _{LOCK}	PLL lock time	-	-	500 μsec	⁽¹⁾

Table 9. PLL AC Characteristics

Note:

(1) Data guaranteed by design.

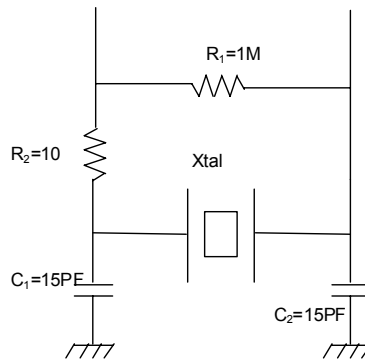

Figure 6. Crystal circuit example

6.2 Analog to Digital Converter AC Characteristics

Unless specified, $T_a = 25^\circ\text{C}$.

Symbol	Parameter	Min	Typ	Max	Condition
T_{CONV}	Conversion time	-	-	2.05 μsec	(1)
T_{HOLD}	Sample/Hold maximum hold time	-	-	10 μsec	Voltage droop ≤ 15 LSB (see figure below)

Table 10 . A/D Converter AC Characteristics

Note:

(1) Data guaranteed by design.

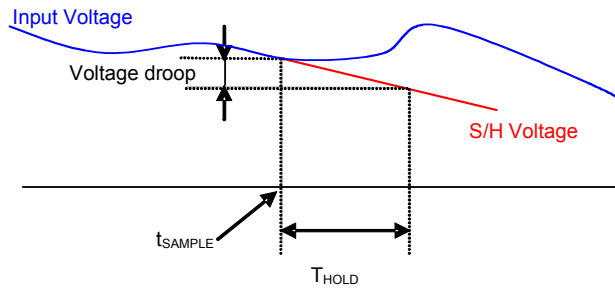

Figure 7. Voltage droop and S/H hold time

6.3 Op amp AC Characteristics

Unless specified, $T_a = 25^\circ\text{C}$.

Symbol	Parameter	Min	Typ	Max	Condition
OP_{SR}	OP amp slew rate	-	10 V/ μsec	-	$V_{DD1} = 3.3\text{ V}$, $CL = 33\text{ pF}$ ⁽¹⁾
OP_{IMP}	OP input impedance	-	$10^8\ \Omega$	-	⁽¹⁾⁽²⁾
T_{SET}	Settling time	-	400 ns	-	$V_{DD1} = 3.3\text{ V}$, $CL = 33\text{ pF}$ ⁽¹⁾

Table 11 Current Sensing OP Amp AC Characteristics

Note:

(1) Data guaranteed by design.

(2) To guarantee stability of the operational amplifier, it is recommended to load the output pin by a capacitor of 47pF, see Figure 8. Here only the single shunt current amplifier is shown but all op amp outputs should be loaded with this capacitor value.

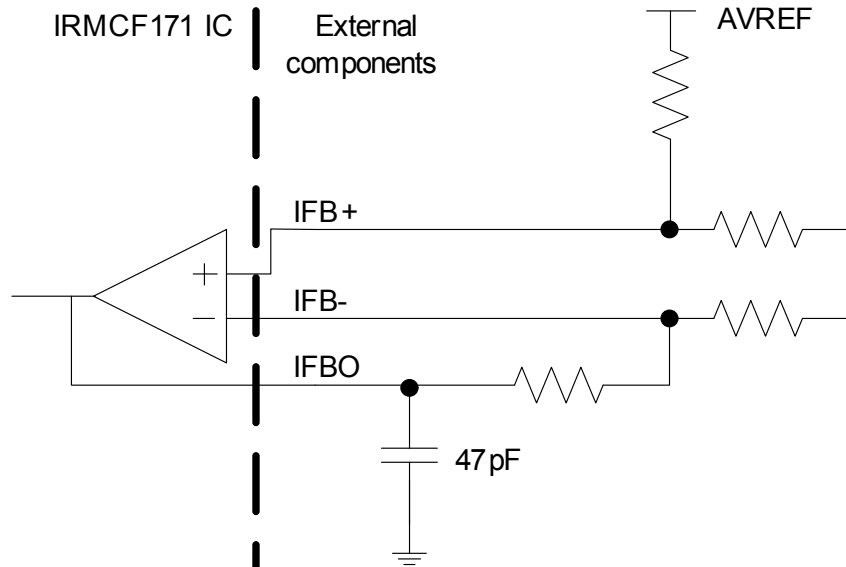

Figure 8 Op amp output capacitor

6.4 SYNC to SVPWM and A/D Conversion AC Timing

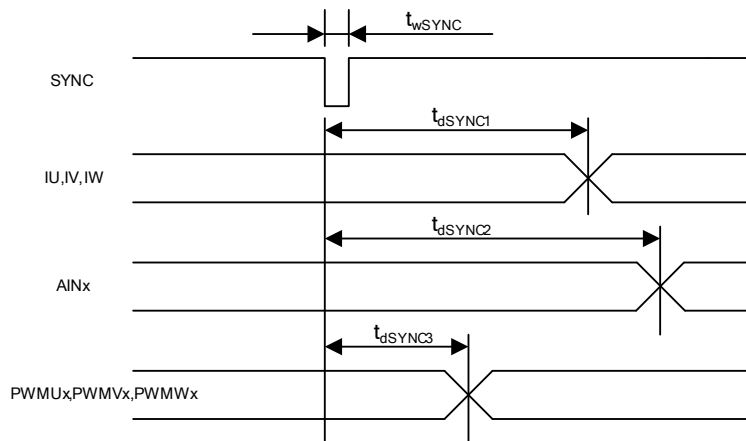

Figure 9. SYNC timing

Unless specified, Ta = 25°C.

Symbol	Parameter	Min	Typ	Max	Unit
$t_{w\text{SYNC}}$	SYNC pulse width	-	32	-	SYSClk
$t_{d\text{SYNC}1}$	SYNC to current feedback conversion time	-	-	100	SYSClk
$t_{d\text{SYNC}2}$	SYNC to AIN0-4, ADCH, ADCL analog input conversion time	-	-	200	SYSClk ⁽¹⁾
$t_{d\text{SYNC}3}$	SYNC to PWM output delay time	-	-	2	SYSClk

Table 12. SYNC AC Characteristics

Note:

(1) AIN1 – AIN5 channels are converted once every 5 SYNC events

6.5 GATEKILL to SVPWM AC Timing

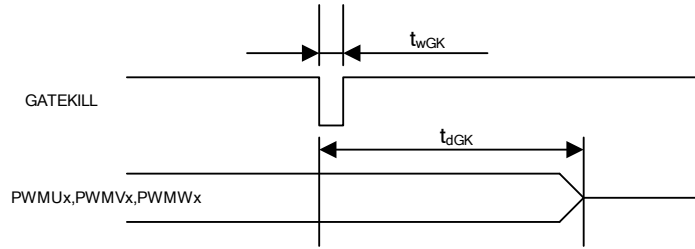

Figure 10. Gatekill timing

Unless specified, Ta = 25°C.

Symbol	Parameter	Min	Typ	Max	Unit
t _{wGK}	GATEKILL pulse width	32	-	-	SYCLK
t _{dGK}	GATEKILL to PWM output delay	-	-	100	SYCLK

Table 13. GATEKILL to SVPWM AC Timing

6.6 Itrip AC Timing

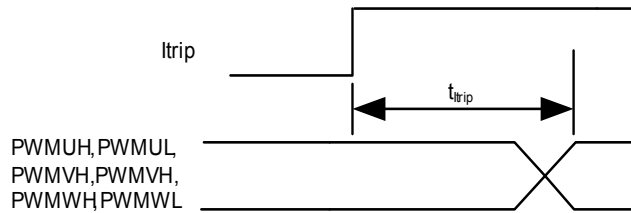

Figure 11. ITRIP timing

Unless specified, Ta = 25°C.

Symbol	Parameter	Min	Typ	Max	Unit
t _{TRIP}	Itrip propagation delay	-	-	100(sysclk)+1.0usec	SYCLK+usec

Table 14. Itrip AC Timing

6.7 Interrupt AC Timing

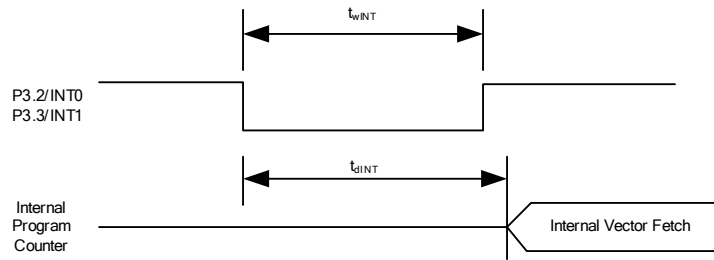

Figure 12. Interrupt timing

Unless specified, Ta = 25°C.

Symbol	Parameter	Min	Typ	Max	Unit
t_{wINT}	INT0, INT1 Interrupt Assertion Time	4	-	-	SYSClk
t_{dINT}	INT0, INT1 latency	-	-	4	SYSClk

Table 15. Interrupt AC Timing

6.8 I²C AC Timing

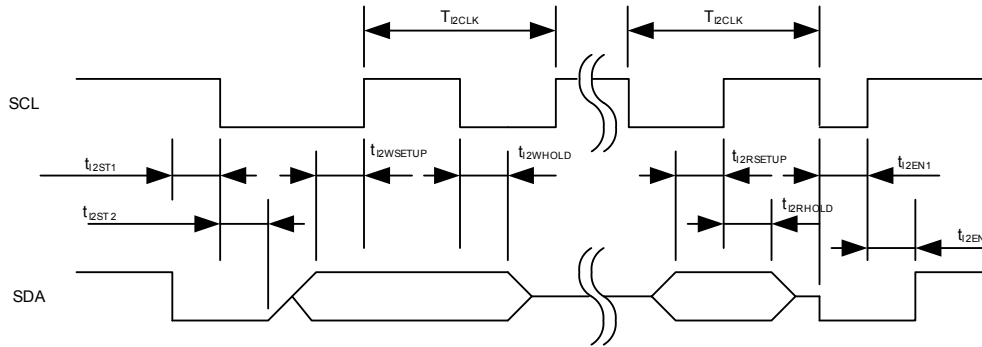

Figure 13. I²C Timing

Unless specified, Ta = 25°C.

Symbol	Parameter	Min	Typ	Max	Unit
T _{I2CLK}	I ² C clock period	10	-	8192	SYCLK
t _{I2ST1}	I ² C SDA start time	0.25	-	-	T _{I2CLK}
t _{I2ST2}	I ² C SCL start time	0.25	-	-	T _{I2CLK}
t _{I2WSETUP}	I ² C write setup time	0.25	-	-	T _{I2CLK}
t _{I2WHOLD}	I ² C write hold time	0.25	-	-	T _{I2CLK}
t _{I2RSETUP}	I ² C read setup time	I ² C filter time ⁽¹⁾	-	-	SYCLK
t _{I2RHOLD}	I ² C read hold time	1	-	-	SYCLK

Table 16. I²C AC Timing

Note:

- (1) I²C read setup time is determined by the programmable filter time applied to I²C communication.

6.9 SPI AC Timing

SPI Write AC timing

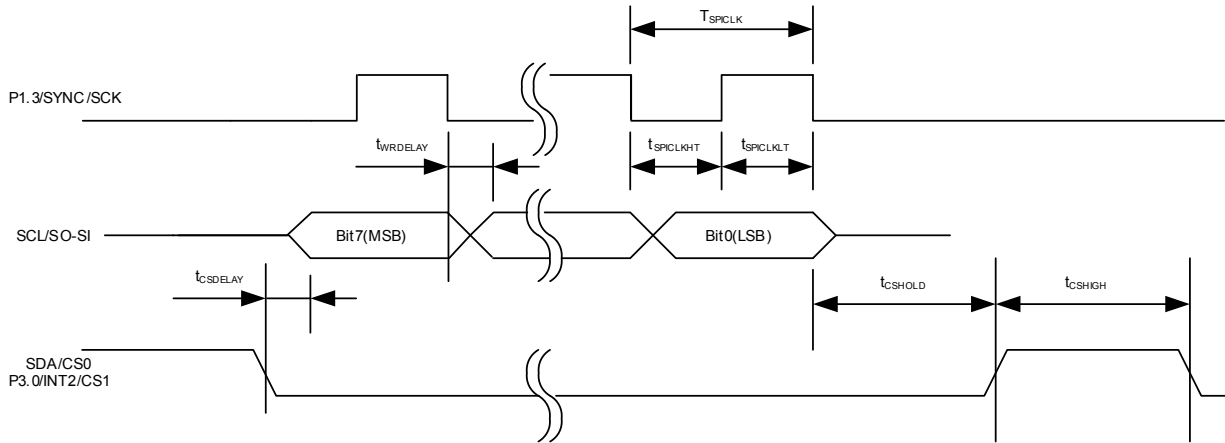

Figure 14. SPI write timing

Unless specified, $T_a = 25^\circ\text{C}$.

Symbol	Parameter	Min	Typ	Max	Unit
T_{SPICLK}	SPI clock period	4	-	-	SYSCCLK
$t_{SPICLKHT}$	SPI clock high time	-	1/2	-	T_{SPICLK}
$t_{SPICLKLT}$	SPI clock low time	-	1/2	-	T_{SPICLK}
$t_{CSDELAY}$	CS to data delay time	-	-	10	nsec
$t_{WRDELAY}$	CLK falling edge to data delay time	-	-	10	nsec
t_{CSHIGH}	CS high time between two consecutive byte transfer	1	-	-	T_{SPICLK}
t_{CSHOLD}	CS hold time	-	1	-	T_{SPICLK}

Table 17. SPI Write AC Timing

SPI Read AC Timing

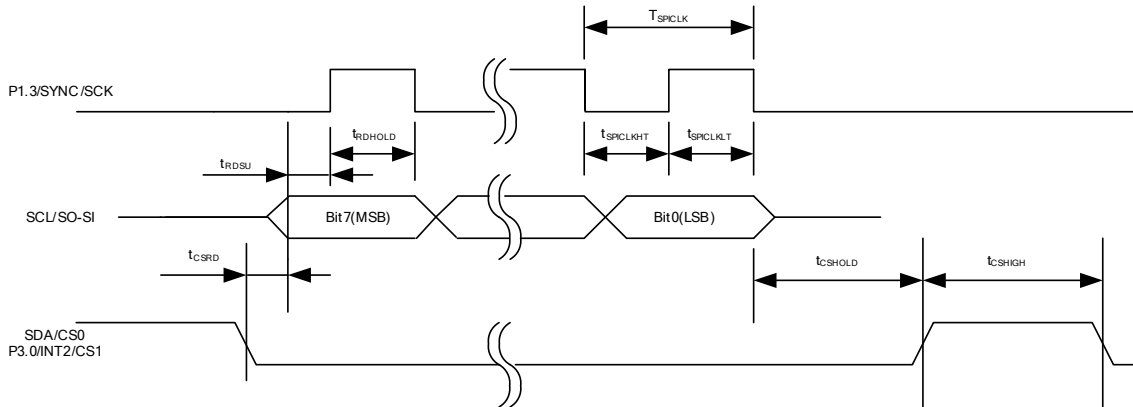

Figure 15. SPI read timing

Unless specified, $T_a = 25^\circ\text{C}$.

Symbol	Parameter	Min	Typ	Max	Unit
T_{SPICLK}	SPI clock period	4	-	-	SYSCCLK
$t_{SPICLKHT}$	SPI clock high time	-	1/2	-	T_{SPICLK}
$t_{SPICLKLT}$	SPI clock low time	-	1/2	-	T_{SPICLK}
t_{CSRd}	CS to data delay time	-	-	10	nsec
t_{RDSU}	SPI read data setup time	10	-	-	nsec
t_{RDHOLD}	SPI read data hold time	10	-	-	nsec
t_{CSHIGH}	CS high time between two consecutive byte transfer	1	-	-	T_{SPICLK}
t_{CSHOLD}	CS hold time	-	1	-	T_{SPICLK}

Table 18. SPI Read AC Timing

6.10 UART AC Timing

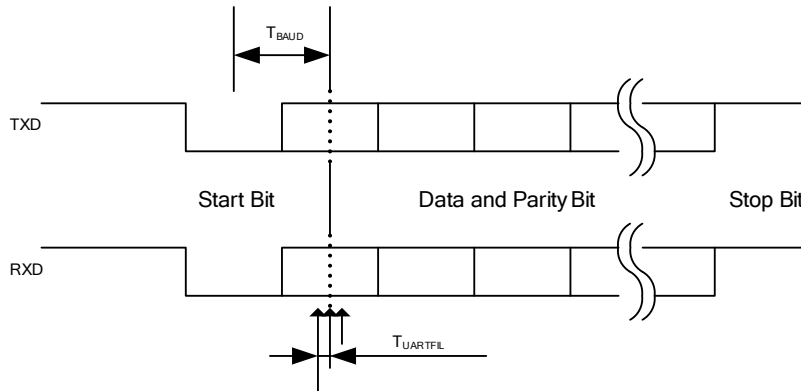

Figure 16. UART timing

Unless specified, $T_a = 25^\circ\text{C}$.

Symbol	Parameter	Min	Typ	Max	Unit
T_{BAUD}	Baud Rate Period	-	57600	-	bit/sec
T_{UARTFIL}	UART sampling filter period ⁽¹⁾	-	1/16	-	T_{BAUD}

Table 19. UART AC Timing

Note:

- (1) Each bit including start and stop bit is sampled three times at center of a bit at an interval of $1/16 T_{\text{BAUD}}$. If three sampled values do not agree, then UART noise error is generated.

6.11 CAPTURE Input AC Timing

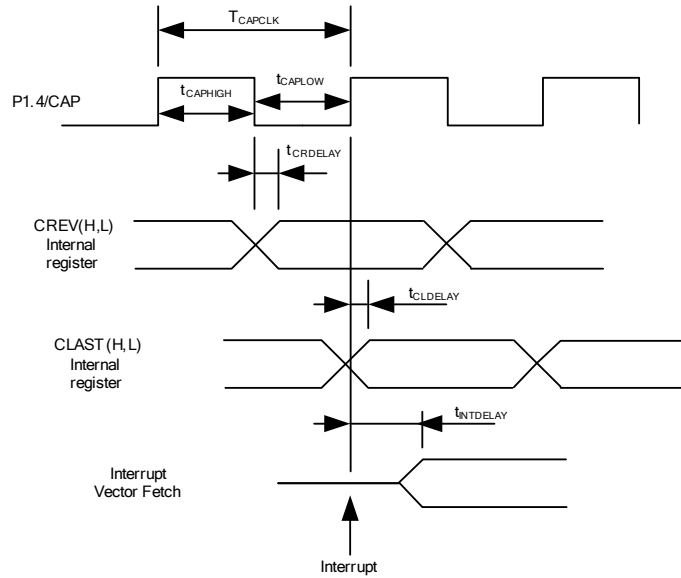

Figure 17. CAPTURE timing

Unless specified, $T_a = 25^\circ\text{C}$.

Symbol	Parameter	Min	Typ	Max	Unit
T_{CAPCLK}	CAPTURE input period	8	-	-	SYSCCLK
$t_{CAPHIGH}$	CAPTURE input high time	4	-	-	SYSCCLK
t_{CAPLOW}	CAPTURE input low time	4	-	-	SYSCCLK
$t_{CRDELAY}$	CAPTURE falling edge to capture register latch time	-	-	4	SYSCCLK
$t_{CLDELAY}$	CAPTURE rising edge to capture register latch time	-	-	4	SYSCCLK
$t_{INTDELAY}$	CAPTURE input interrupt latency time	-	-	4	SYSCCLK

Table 20. CAPTURE AC Timing

6.12 JTAG AC Timing

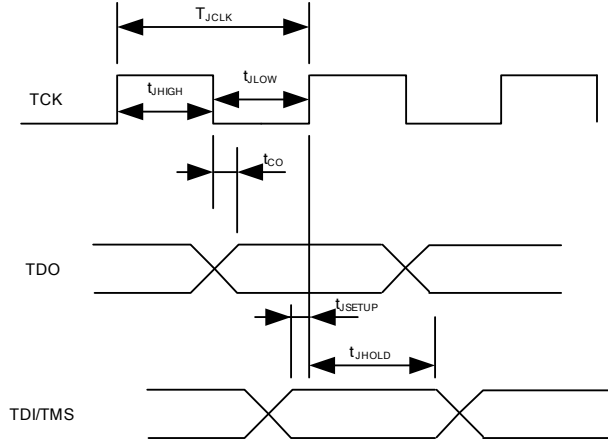

Figure 18. JTAG timing

Unless specified, $T_a = 25^\circ\text{C}$.

Symbol	Parameter	Min	Typ	Max	Unit
T_{JCLK}	TCK Period	-	-	50	MHz
t_{JHIGH}	TCK High Period	10	-	-	nsec
t_{JLOW}	TCK Low Period	10	-	-	nsec
t_{CO}	TCK to TDO propagation delay time	0	-	5	nsec
t_{JSETUP}	TDI/TMS setup time	4	-	-	nsec
t_{JHOLD}	TDI/TMS hold time	0	-	-	nsec

Table 21. JTAG AC Timing

7 I/O Structure

The following figure shows the motor PWM output (PWMUH/PWMUL/PWMVH/PWMVL/PWMWH/PMMWL)

Figure 19. PWMUL/PWMUH/PWMVL/PWMVH/PMMWL/PMMWH output

The following figure shows the digital I/O structure except the motor PWM output

Figure 20. All digital I/O except motor PWM output

The following figure shows RESET and GATEKILL I/O structure.

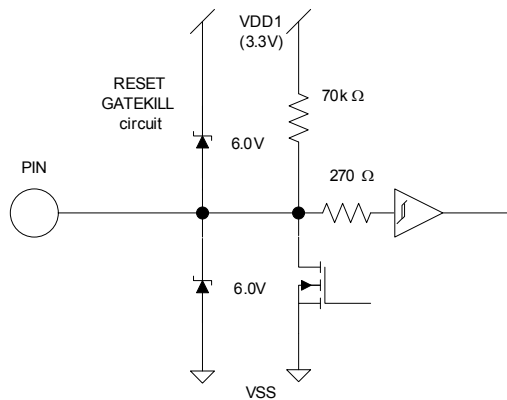

Figure 21. RESET, GATEKILL I/O

The following figure shows the analog input structure.

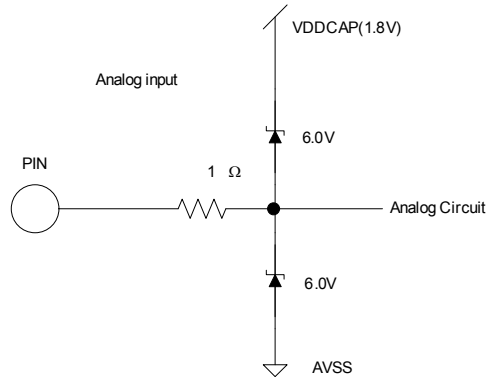

Figure 22. Analog input

The following figure shows all analog operational amplifier output pins and AREF pin I/O structure.

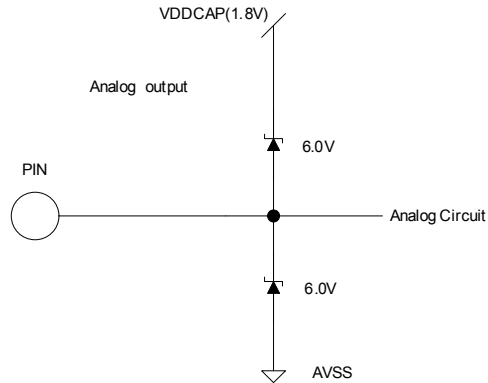

Figure 23 Analog operational amplifier output and AREF I/O structure

The following figure shows the VSS,AVSS pin I/O structure

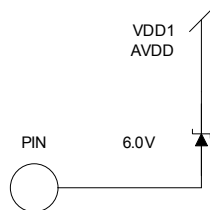

Figure 24. VSS,AVSS pin I/O structure

The following figure shows the VDD1,VDDCAP pin I/O structure

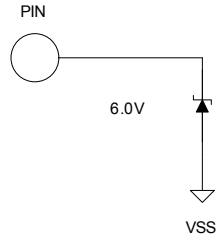

Figure 25. VDD1,VDDCAP pin I/O structure

The following figure shows the XTAL0 and XTAL1 pins structure

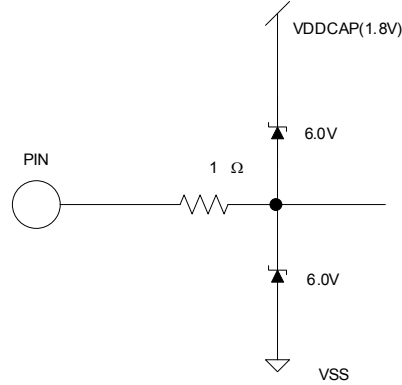

Figure 26. XTAL0/XTAL1 pins structure

8 Pin List

Pin Number	Pin Name	Internal Pull-up /Pull-down	Pin Type	Description
1	XTAL0		I	Crystal input
2	XTAL1		O	Crystal output
3	P1.0/T2		I/O	Discrete programmable I/O or Timer/Counter 2 input
4	SCL/SO-SI		I/O	I ² C clock output (open drain, need pull up) or SPI data
5	SDA/CS0		I/O	I ² C data (open drain, need pull up) or SPI Chip Select 0
6	P1.3/SYNC/SCK		I/O	Discrete programmable I/O or SYNC output or SPI clock output
7	P1.4/CAP		I/O	Discrete programmable I/O or Capture timer input
8	VDD1		P	3.3V digital power
9	VSS		P	Digital common
10	VDDCAP		P	Internal 1.8V output, Capacitor(s) to be connected
11	P2.0/NMI		I/O	Discrete programmable I/O or Non-maskable Interrupt input
12	P3.2/INT0		I/O	Discrete programmable I/O or Interrupt 0 input
13	P2.7/AOPWM1		I/O	Discrete programmable I/O or PWM 1 digital output
14	AIN0		I	Analog input channel 0, 0-1.2V range, needs to be pulled down to AVSS if unused
15	AIN1		I	Analog input channel 1, 0-1.2V range, needs to be pulled down to AVSS if unused
16	AIN2		I	Analog input channel 2, 0-1.2V range, needs to be pulled down to AVSS if unused
17	AIN3		I	Analog input channel 3, 0-1.2V range, needs to be pulled down to AVSS if unused
18	AIN4		I	Analog input channel 4, 0-1.2V range, needs to be pulled down to AVSS if unused
19	IFB-		I	Single shunt current sensing OP amp input (-)
20	IFB+		I	Single shunt current sensing OP amp input (+)
21	IFBO		O	Single shunt current sensing OP amp output
22	CMEXT		O	Unbuffered 0.6V output. Capacitor needs to be connected.
23	AREF		O	Analog reference voltage output (0.6V)
24	AIN5-		I	Analog input channel 5, 0-1.2V range, needs to be pulled down to AVSS if unused
25	AIN5+		I	Analog input channel 5, 0-1.2V range, needs to be pulled down to AVSS if unused
26	AIN5O		O	Analog output 5, 0-1.2V range,
27	AVSS		P	Analog common
28	VDDCAP		P	Internal 1.8V output, Capacitor(s) to be connected
29	VDD1		P	3.3V digital power
30	VSS		P	Digital common
31	P3.1/AOPWM2		I/O	Discrete programmable I/O or PWM 2 digital output
32	PWMWL	58 k Ω Pull down	O	PWM gate drive for phase W low side, configurable either high or low true.
33	PWMVL	58 k Ω Pull down	O	PWM gate drive for phase V low side, configurable either high or low true

Pin Number	Pin Name	Internal Pull-up /Pull-down	Pin Type	Description
34	PWMUL	58 kΩ Pull down	O	PWM gate drive for phase U low side, configurable either high or low true
35	PWMWH	58 kΩ Pull down	O	PWM gate drive for phase W high side, configurable either high or low true
36	PWMVH	58 kΩ Pull down	O	PWM gate drive for phase V high side, configurable either high or low true
37	PWMUH	58 kΩ Pull down	O	PWM gate drive for phase U high side, configurable either high or low true
38	P1.5		I/O	Discrete programmable I/O.
39	GATEKILL	70 kΩ Pull up	I	PWM shutdown input, configurable digital filter, active low input.
40	P3.0/INT2/CS1	70 kΩ Pull up	I/O	Discrete programmable I/O or external interrupt 2 input or SPI Chip Select 1
41	P5.2/TMS		I	JTAG test mode input or input digital port
42	TDO		O	JTAG test data output
43	P5.1/TDI		I	JTAG test data input or input digital port
44	TCK		I	JTAG test clock
45	RESET		I	Reset, low true, Schmitt trigger input
46	P1.1/RXD		I/O	UART receiver input or Discrete programmable I/O
47	P1.2/RXD		I/O	UART transmitter output or Discrete programmable I/O
48	P3.3/INT1		I/O	Interrupt 1 input or Discrete I/O

Table 22. Pin List

9 Package Dimensions

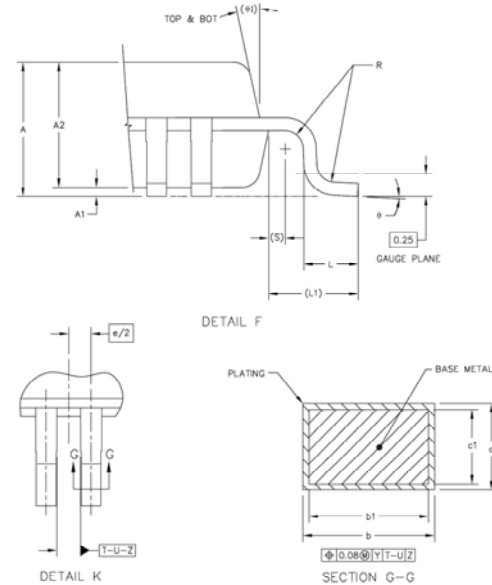
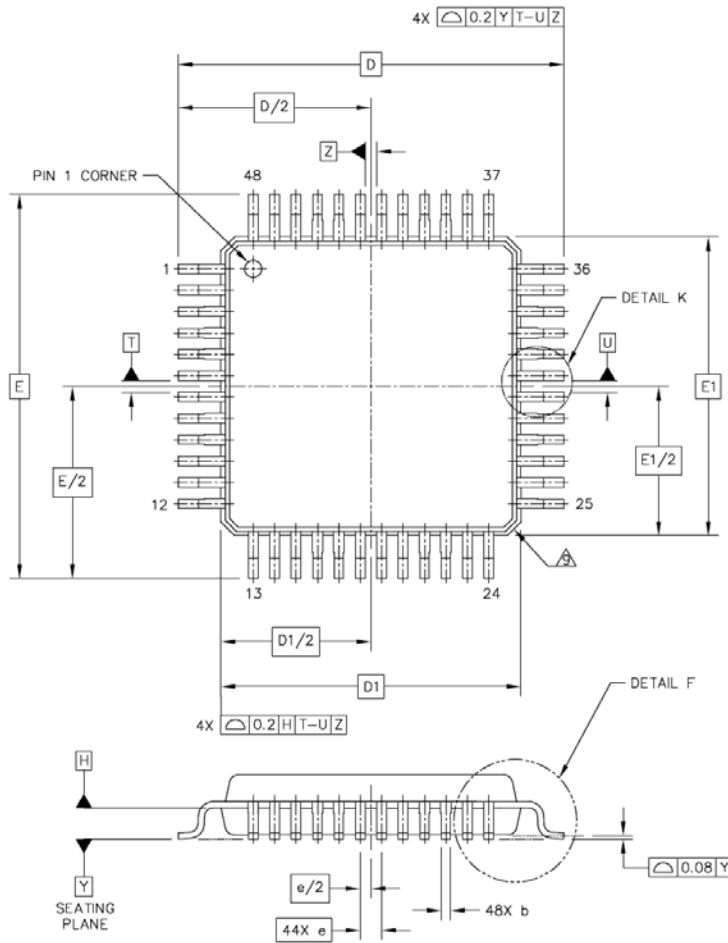
NOTES:

- DIMENSIONS ARE IN MILLIMETERS.
- INTERPRET DIMENSIONS AND TOLERANCES PER ASME Y14.5M-1994.
- DATUM PLANE H IS LOCATED AT BOTTOM OF LEAD AND IS COINCIDENT WITH THE LEAD WHERE THE LEAD EXITS THE PLASTIC BODY AT THE BOTTOM OF THE PARTING LINE.
- DATUM T, U AND Z TO BE DETERMINED AT DATUM PLANE H.
- DIMENSIONS D AND E TO BE DETERMINED AT SEATING PLANE Y.
- DIMENSIONS D1 AND E1 DO NOT INCLUDE MOLD PROTRUSION. ALLOWABLE PROTRUSION IS 0.25 PER SIDE. DIMENSIONS D1 AND E1 DO INCLUDE MOLD MISMATCH AND ARE DETERMINED AT DATUM PLANE H.
- DIMENSION b DOES NOT INCLUDE DAM BAR PROTRUSION. DAM BAR PROTRUSION SHALL NOT CAUSE THE b DIMENSION TO EXCEED 0.35.
- MINIMUM SOLDER PLATE THICKNESS SHALL BE 0.0076.
- EXACT SHAPE OF EACH CORNER IS OPTIONAL.

DIM	MIN	MAX	DIM	MIN	MAX	DIM	MIN	MAX
A	1.4	1.6	L1	1 REF				
A1	0.05	0.15	R	0.15	0.25			
A2	1.35	1.45	S	0.2 REF				
b	0.17	0.27	θ	1°	5°			
b1	0.17	0.23	θ1	12° REF				
c	0.09	0.2						
c1	0.09	0.16						
D		9 BSC						
D1		7 BSC						
e		0.5 BSC						
E		9 BSC						
E1		7 BSC						
L	0.5	0.7						

10 Part Marking Information

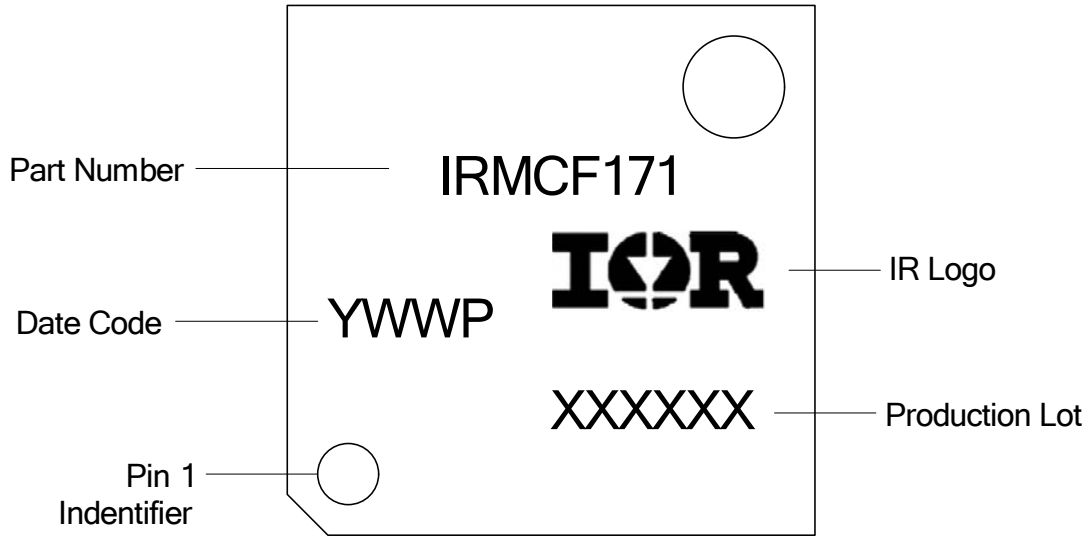

11 Qualification Information †

Qualification Level		Industrial ^{††} (per JEDEC JESD 47E)
Moisture Sensitivity Level		MSL3 ^{†††} (per IPC/JEDEC J-STD-020C)
ESD	Machine Model	Class B (per JEDEC standard JESD22-A114D)
	Human Body Model	Class 2 (per EIA/JEDEC standard EIA/JESD22-A115-A)
RoHS Compliant		Yes

† Qualification standards can be found at International Rectifier’s web site <http://www.irf.com/>

†† Higher qualification ratings may be available should the user have such requirements. Please contact your International Rectifier sales representative for further information.

††† Higher MSL ratings may be available for the specific package types listed here. Please contact your International Rectifier sales representative for further information.

Revision History

Rev A First Revision
(March 10, 2013)

International
 Rectifier

Data and Specifications are subject to change without notice

IR WORLD HEADQUARTERS: 233 Kansas St., El Segundo, California 90245, USA Tel: (310) 252-7105

TAC Fax: (310) 252-7903

Visit us at www.irf.com for sales contact information