

# HDMI

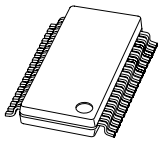

## IP4776CZ38

Fully integrated HDMI interface with level shifter, ESD and backdrive protection

Rev. 6 — 7 January 2011

Product data sheet

### 1. General description

---

The IP4776CZ38 is designed for HDMI host-interface protection. The IP4776CZ38 includes level shifting for the DDC channels and backdrive protection for HDMI as well as high-level ESD protection diodes for the TMDS signal lines.

The level shifting function is required when the receiver operates at a supply voltage lower than the external devices to protect the I/Os against overvoltages. The IP4776CZ38 contains four N-channel MOSFETs to provide this level shifting function.

Furthermore, all TMDS intra-pairs are protected by a special diode configuration offering an ultra low line capacitance of 0.7 pF only. These diodes provide protection to downstream components from ESD voltages up to  $\pm 8$  kV contact according to the IEC 61000-4-2, level 4 standard.

### 2. Features and benefits

---

- Pb-free and RoHS compliant, Dark Green
- Integrated high-level ESD protection, level shifting and backdrive protection
- All TMDS lines with integrated rail-to-rail clamping diodes with downstream ESD protection of  $\pm 8$  kV according to IEC 61000-4-2, level 4 standard
- Matched 0.5 mm trace spacing
- Bidirectional level shifting N-channel FETs provided for DDC clock and data channels
- TMDS lines with  $\leq 0.05$  pF matching of capacitance between the TMDS pairs
- Ultra low line capacitance of 0.7 pF per channel
- HDMI 1.3 compliant
- Backdrive protection
- 38-pin TSSOP lead-free package

### 3. Applications

---

- The IP4776CZ38 is designed for HDMI receiver and transmitter port protection, level shifting and backdrive protection e.g.:
  - ◆ TV
  - ◆ Graphics card
  - ◆ Set-top box
  - ◆ DVD
  - ◆ Digital media adapter
  - ◆ Game console



### 4. Ordering information

Table 1. Ordering information

Type number	Package		Version
	Name	Description	
IP4776CZ38	TSSOP38	plastic thin shrink small outline package; 38 leads; body width 4.4 mm; lead pitch 0.5 mm	SOT510-1

### 5. Functional diagram

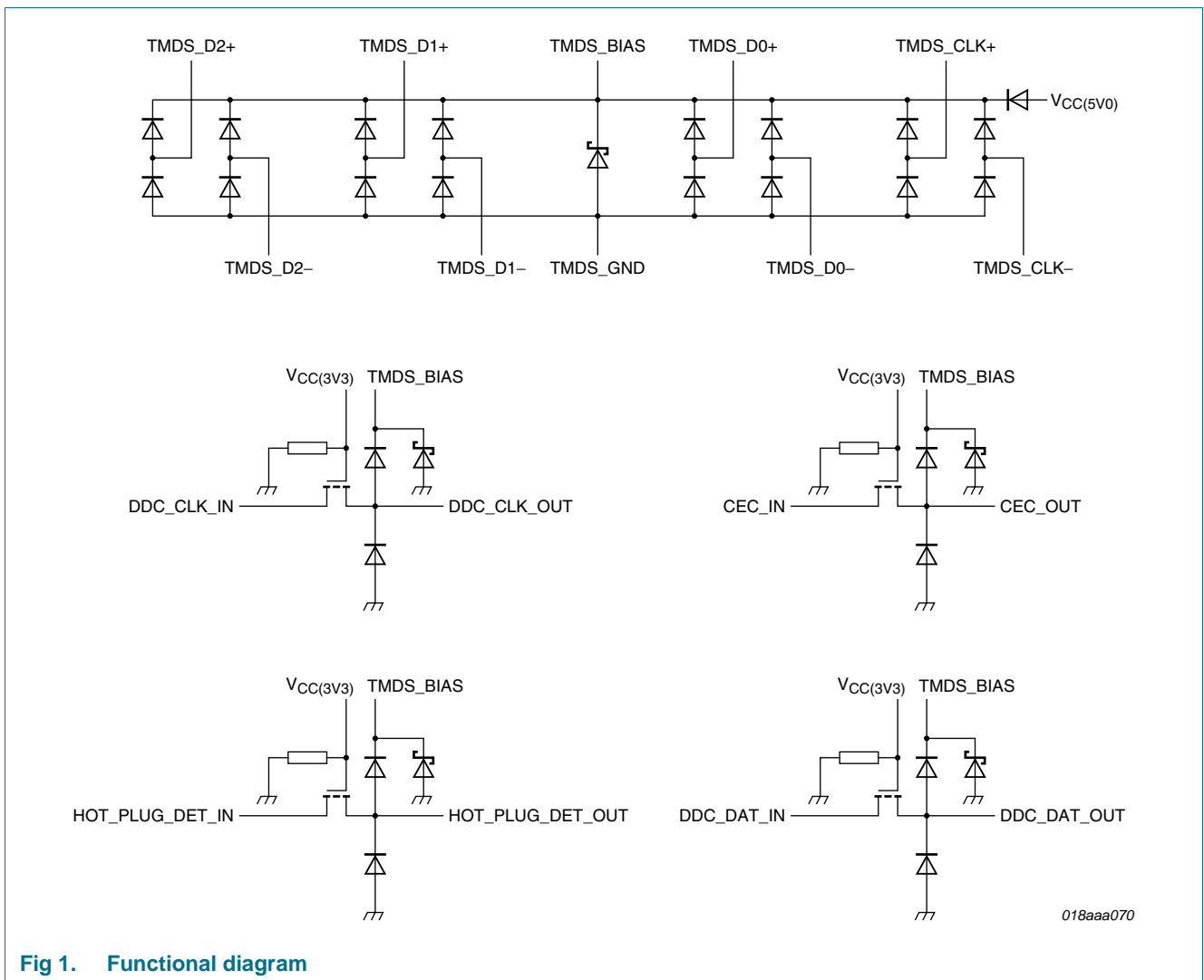
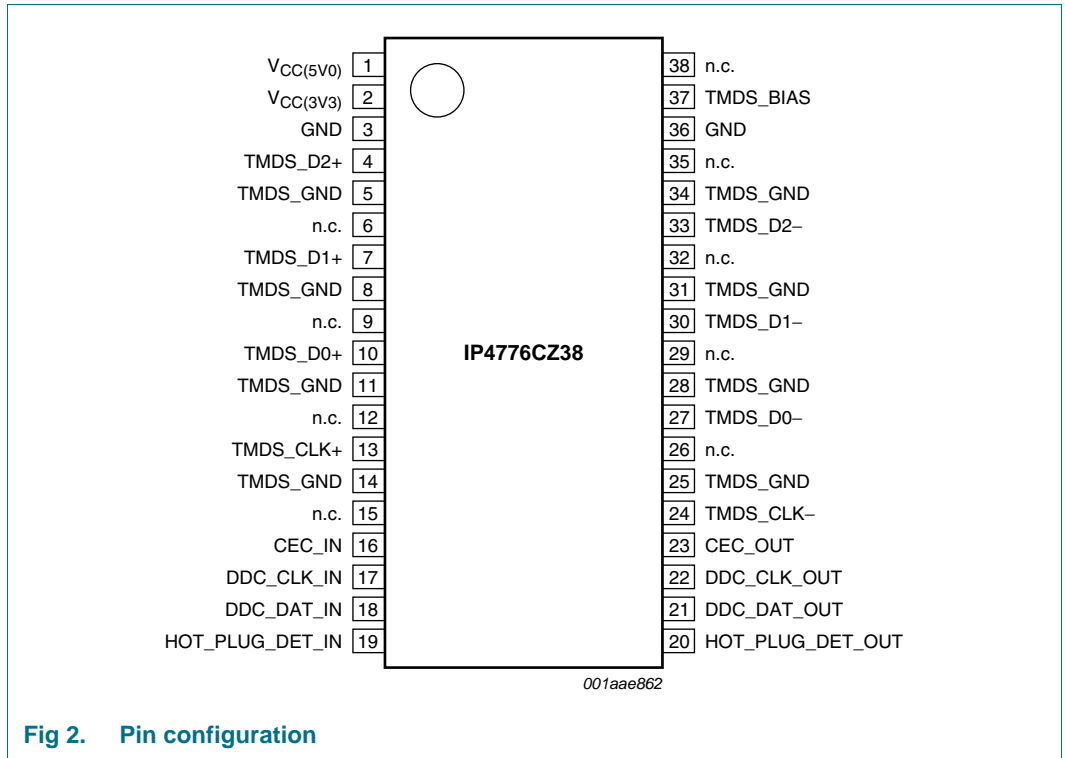

Fig 1. Functional diagram

## 6. Pinning information

### 6.1 Pinning



### 6.2 Pin description

Table 2. Pin description

Symbol	Pin	Description
V <sub>CC(5V0)</sub>	1	supply voltage
V <sub>CC(3V3)</sub>	2	bias supply voltage for the level shifters
GND	3	ground reference <sup>[1]</sup>
TMDS_D2+	4	D2+ TMDS ESD protection <sup>[2]</sup>
TMDS_GND	5	ground reference <sup>[1]</sup>
n.c.	6	not connected <sup>[2]</sup>
TMDS_D1+	7	D1+ TMDS ESD protection <sup>[2]</sup>
TMDS_GND	8	ground reference <sup>[1]</sup>
n.c.	9	not connected <sup>[2]</sup>
TMDS_D0+	10	D0+ TMDS ESD protection <sup>[2]</sup>
TMDS_GND	11	ground reference <sup>[1]</sup>
n.c.	12	not connected <sup>[2]</sup>
TMDS_CLK+	13	CLK+ TMDS ESD protection <sup>[2]</sup>
TMDS_GND	14	ground reference <sup>[1]</sup>
n.c.	15	not connected <sup>[2]</sup>

Table 2. Pin description ...continued

Symbol	Pin	Description
CEC_IN	16	CEC input <sup>[3]</sup>
DDC_CLK_IN	17	DDC clock input <sup>[3]</sup>
DDC_DAT_IN	18	DDC data input <sup>[3]</sup>
HOT_PLUG_DET_IN	19	hot plug detection input <sup>[3]</sup>
HOT_PLUG_DET_OUT	20	hot plug detection output <sup>[4]</sup>
DDC_DAT_OUT	21	DDC data output <sup>[4]</sup>
DDC_CLK_OUT	22	DDC clock output <sup>[4]</sup>
CEC_OUT	23	CEC output <sup>[3]</sup>
TMDS_CLK-	24	CLK- TMDS ESD protection <sup>[2]</sup>
TMDS_GND	25	ground reference <sup>[1]</sup>
n.c.	26	not connected <sup>[2]</sup>
TMDS_D0-	27	D0- TMDS ESD protection <sup>[2]</sup>
TMDS_GND	28	ground reference <sup>[1]</sup>
n.c.	29	not connected <sup>[2]</sup>
TMDS_D1-	30	D1- TMDS ESD protection <sup>[2]</sup>
TMDS_GND	31	ground reference <sup>[1]</sup>
n.c.	32	not connected <sup>[2]</sup>
TMDS_D2-	33	D2- TMDS ESD protection <sup>[2]</sup>
TMDS_GND	34	ground reference <sup>[1]</sup>
n.c.	35	not connected <sup>[2]</sup>
GND	36	ground reference <sup>[1]</sup>
TMDS_BIAS	37	bias for TMDS ESD protection and bias for level shifter output ESD protection. This pin must be connected to a 0.1 $\mu$ F capacitor.
n.c.	38	not connected

[1] Pins GND and TMDS\_GND are internally connected.

[2] This pin always has to be connected to the pin on the opposite location of the IC via a PCB track to guarantee correct functionality; see [Figure 3](#), [Figure 4](#) and [Figure 5](#).

[3]  $V_{CC(3V3)}$  referenced logic level in.

[4]  $V_{CC(5V0)}$  referenced logic level out.

## 7. Limiting values

**Table 3. Limiting values**
*In accordance with the Absolute Maximum Rating System (IEC 60134).*

Symbol	Parameter	Conditions	Min	Max	Unit	
$V_{CC}$	supply voltage		GND – 0.5	5.5	V	
$V_I$	input voltage	at input pins	GND – 0.5	5.5	V	
$V_{ESD}$	electrostatic discharge voltage	signal pins; IEC 61000-4-2, level 4	[1]			
		contact	[2]	–8	+8	kV
		air discharge	[2]	–15	+15	kV
		all other pins; MIL-STD-883 Method 3015 (human body model)				
		contact		–2	+2	kV
		air discharge		–2	+2	kV
$T_{stg}$	storage temperature		–55	+125	°C	

[1] Signal pins:

TMDS\_D2+, TMDS\_D2–, TMDS\_D1+, TMDS\_D1–, TMDS\_D0+, TMDS\_D0–,  
 TMDS\_CLK+, TMDS\_CLK–,  
 CEC\_OUT,  
 DDC\_DAT\_OUT,  
 DDC\_CLK\_OUT,  
 HOT\_PLUG\_DET\_OUT.

[2] This measurement is performed with a 0.1  $\mu$ F external capacitor on pin TMDS\_BIAS.

## 8. Recommended operating conditions

**Table 4. Recommended operating conditions**

Symbol	Parameter	Conditions	Min	Typ	Max	Unit
$T_{amb}$	ambient temperature		–40	-	+85	°C

## 9. Characteristics

**Table 5. Characteristics**
 *$T_{amb} = 25$  °C; unless otherwise specified.*

Symbol	Parameter	Conditions	Min	Typ	Max	Unit	
$I_{CC(5V0)}$	supply current (5.0 V)	$V_{CC(5V0)} = 5.0$ V	-	-	130	$\mu$ A	
$I_{CC(3V3)}$	supply current (3.3 V)	$V_{CC(3V3)} = 3.3$ V	-	1	5	$\mu$ A	
$I_{bck(out-VCC5V0)}$	back current from output / TMDS pins to $V_{CC(5V0)}$	signal pins; powered down; $V_{CC(5V0)} < V_{O(ch)}$	[1]	-	0.1	0.5	$\mu$ A
$V_{BRzd}$	Zener diode breakdown voltage	$I = 1$ mA	6	-	9	V	
$I_{L(r)}$	reverse leakage current	per TMDS channel; $V_I = 3.0$ V	-	-	1	$\mu$ A	
$V_F$	forward voltage		-	0.7	-	V	
$C_{ch(TMDS)}$	TMDS channel capacitance	$V_{CC(5V0)} = 5$ V; $f = 1$ MHz; $V_{bias} = 2.5$ V	[2]	-	0.7	-	pF

**Table 5. Characteristics ...continued**  
 $T_{amb} = 25\text{ }^{\circ}\text{C}$ ; unless otherwise specified.

Symbol	Parameter	Conditions	Min	Typ	Max	Unit
$\Delta C_{ch(TMDS)}$	TMDS channel capacitance difference	$V_{CC(5V0)} = 5\text{ V}$ ; $f = 1\text{ MHz}$ ; $V_{bias} = 2.5\text{ V}$	[2] -	0.05	-	pF
$C_{ch(mutual)}$	mutual channel capacitance	between signal pin and pin n.c.; $V_{CC(5V0)} = 0\text{ V}$ ; $f = 1\text{ MHz}$ ; $V_{bias} = 2.5\text{ V}$	[2] -	0.07	-	pF
$C_{l(ch-GND)(levsh)}$	level shifting input capacitance from channel to ground	$V_{CC(5V0)} = 0\text{ V}$ ; $f = 1\text{ MHz}$ ; $V_{bias} = 2.5\text{ V}$	[2] -	4	6	pF
$R_{dyn}$	dynamic resistance	$I = 1\text{ A}$ ; IEC 61000-4-5/9				
		positive transient	-	2.4	-	$\Omega$
		negative transient	-	1.3	-	$\Omega$
$V_{CL(ch)trt(pos)}$	positive transient channel clamping voltage	$V_{ESD} = 8\text{ kV}$	[3] -	8	-	V
$\Delta V_{on}$	on-state voltage drop	$V_{CC(3V3)} = 2.5\text{ V}$ ; $V_S = \text{GND}$ ; $I_{DS} = 3\text{ mA}$	[4] -	85	140	mV

- [1] Signal pins:  
 TMDS\_D2+, TMDS\_D2-, TMDS\_D1+, TMDS\_D1-, TMDS\_D0+, TMDS\_D0-,  
 TMDS\_CLK+, TMDS\_CLK-,  
 CEC\_OUT,  
 DDC\_DAT\_OUT,  
 DDC\_CLK\_OUT,  
 HOT\_PLUG\_DET\_OUT.
- [2] This parameter is guaranteed by design.
- [3] This measurement is performed with a 0.1  $\mu\text{F}$  external capacitor on pin TMDS\_BIAS.
- [4] For level shifting N-FET.

10. Application information

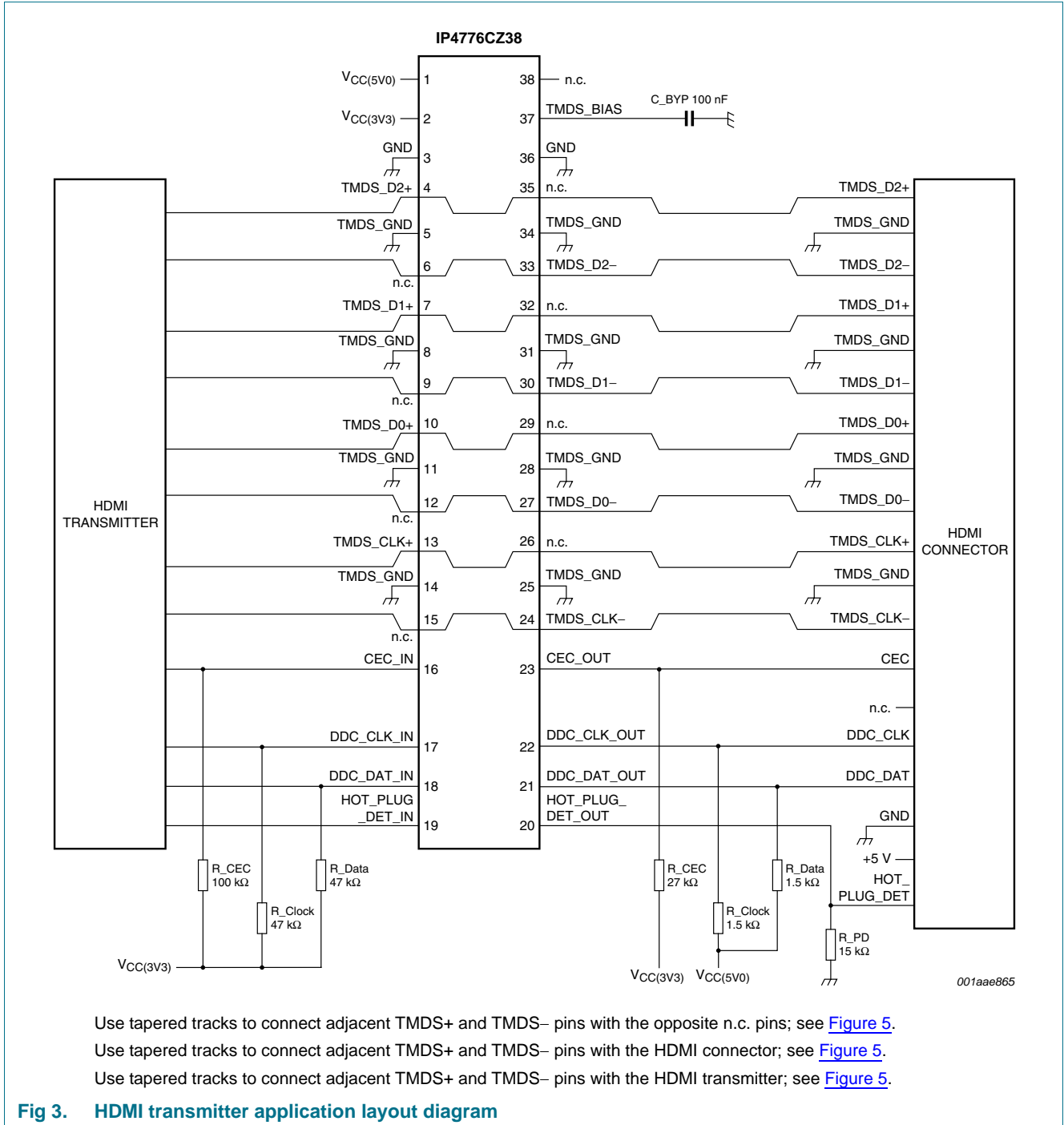

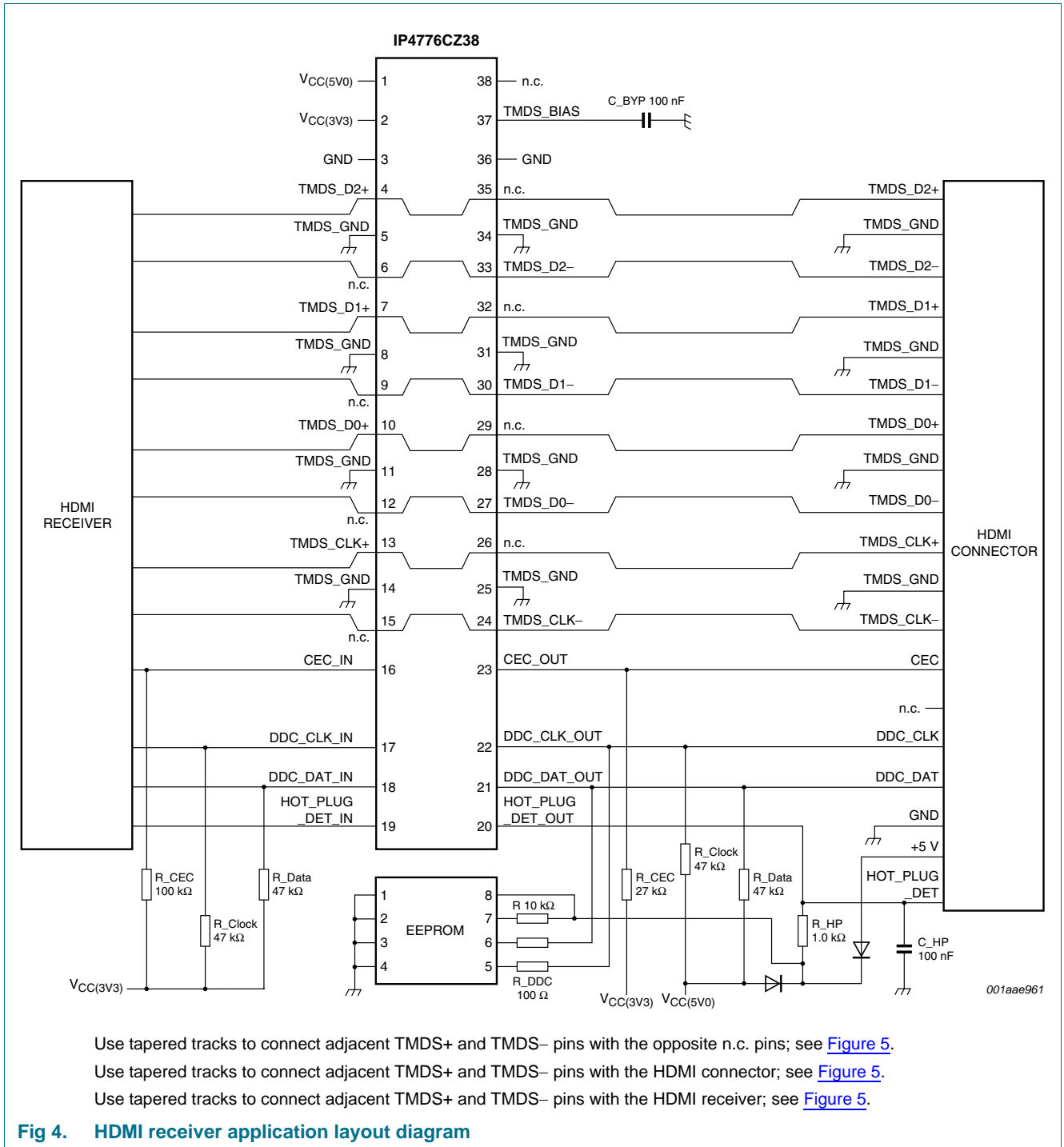



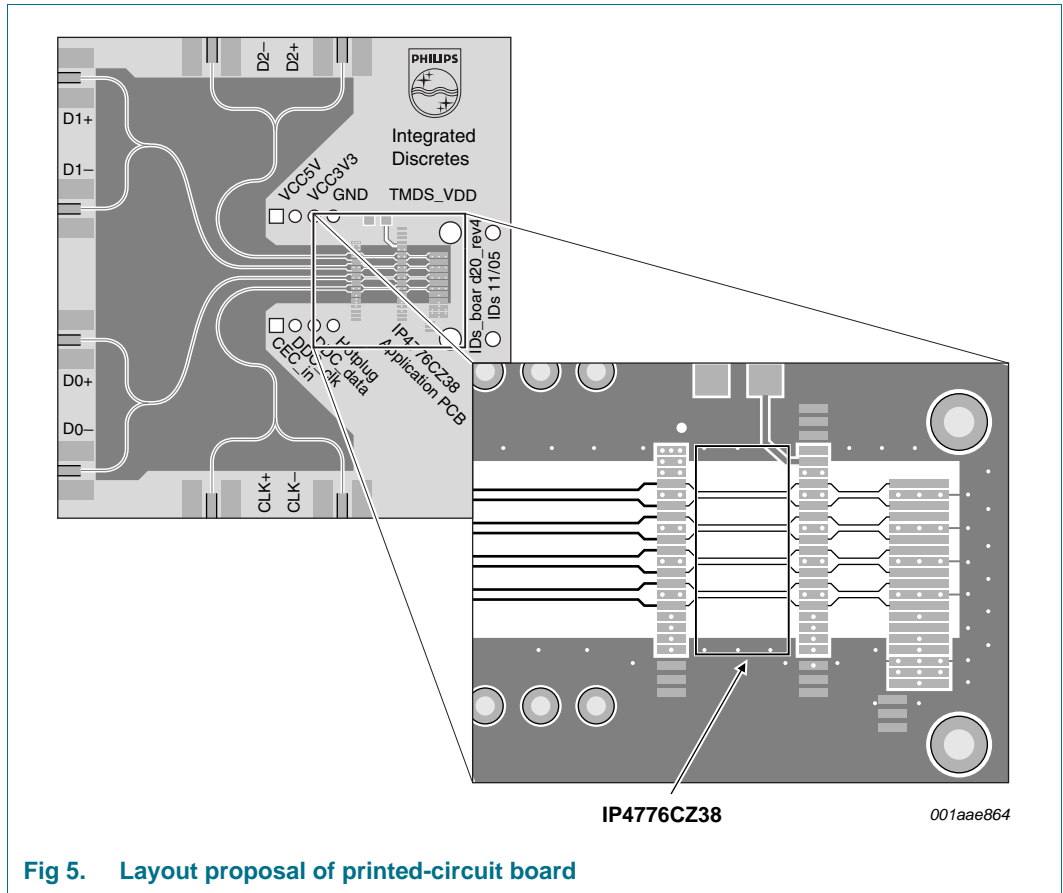

**Fig 5. Layout proposal of printed-circuit board**

### 11. Package outline

TSSOP38: plastic thin shrink small outline package; 38 leads; body width 4.4 mm; lead pitch 0.5 mm

SOT510-1

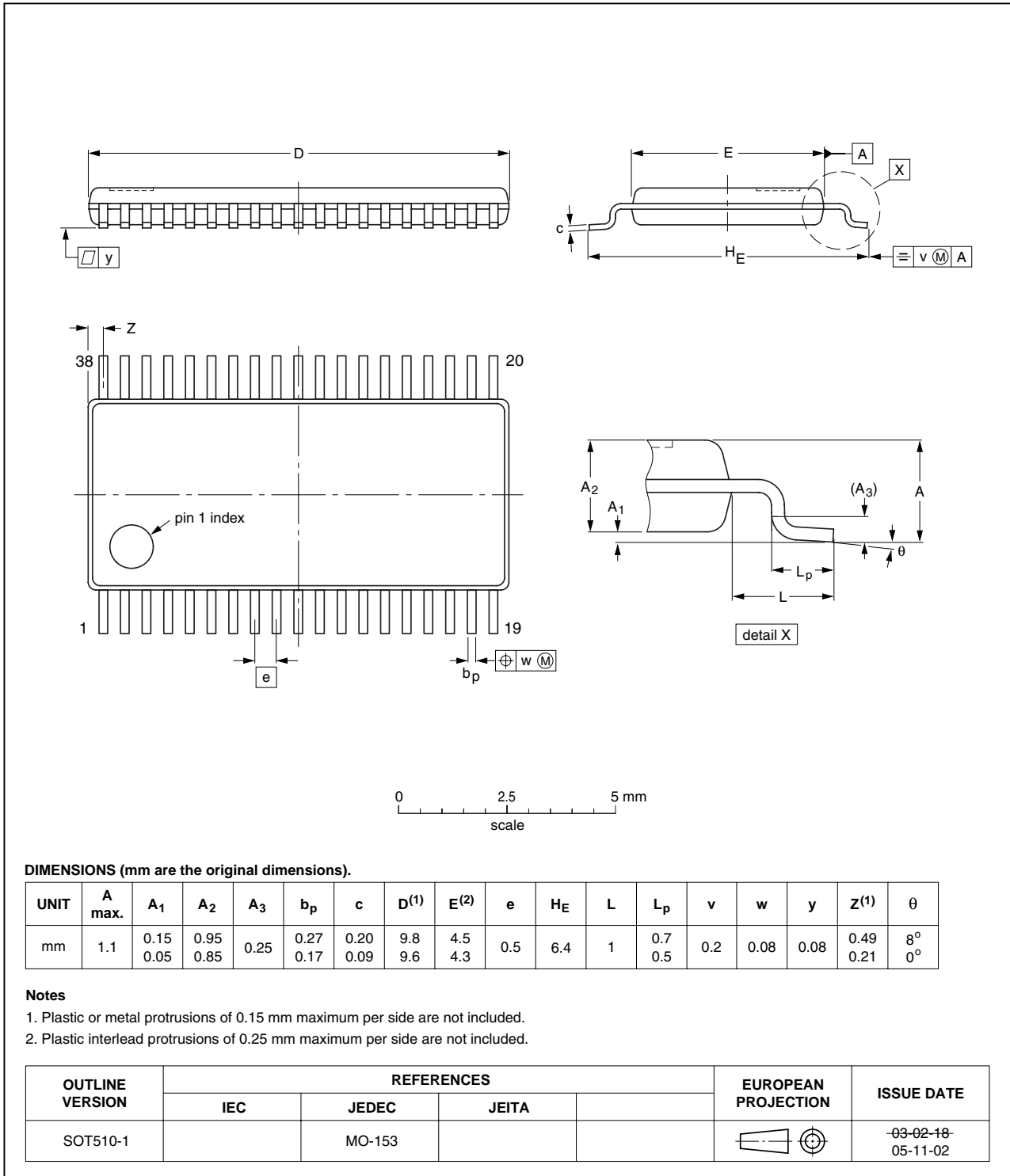

Fig 6. Package outline SOT510-1 (TSSOP38)

## 12. Abbreviations

Table 6. Abbreviations

Acronym	Description
CEC	Consumer Electronics Control
DDC	Data Display Channel
DVD	Digital Video Disk
ESD	ElectroStatic Discharge
FET	Field Effect Transistor
HDM	High-Definition Multimedia
HDMI	High-Definition Multimedia Interface
MOSFET	Metal Oxide Semiconductor Field Effect Transistor
PCB	Printed-Circuit Board
RoHS	Restriction of the use of certain Hazardous Substances
TMDS	Transition Minimized Differential Signaling

## 13. Revision history

Table 7. Revision history

Document ID	Release date	Data sheet status	Change notice	Supersedes
IP4776CZ38 v.6	20110107	Product data sheet	-	IP4776CZ38 v.5
Modifications:	• <a href="#">Figure 1</a> : corrected			
IP4776CZ38 v.5	20100706	Product data sheet	-	IP4776CZ38 v.4
IP4776CZ38 v.4	20070612	Product data sheet	-	IP4776CZ38 v.3
IP4776CZ38 v.3	20070125	Product data sheet	-	IP4776CZ38 v.2
IP4776CZ38 v.2	20060918	Product data sheet	-	IP4776CZ38 v.1
IP4776CZ38 v.1	20060714	Product data sheet	-	-

## 14. Legal information

### 14.1 Data sheet status

Document status <sup>[1][2]</sup>	Product status <sup>[3]</sup>	Definition
Objective [short] data sheet	Development	This document contains data from the objective specification for product development.
Preliminary [short] data sheet	Qualification	This document contains data from the preliminary specification.
Product [short] data sheet	Production	This document contains the product specification.

[1] Please consult the most recently issued document before initiating or completing a design.

[2] The term 'short data sheet' is explained in section "Definitions".

[3] The product status of device(s) described in this document may have changed since this document was published and may differ in case of multiple devices. The latest product status information is available on the Internet at URL <http://www.nxp.com>.

### 14.2 Definitions

**Draft** — The document is a draft version only. The content is still under internal review and subject to formal approval, which may result in modifications or additions. NXP Semiconductors does not give any representations or warranties as to the accuracy or completeness of information included herein and shall have no liability for the consequences of use of such information.

**Short data sheet** — A short data sheet is an extract from a full data sheet with the same product type number(s) and title. A short data sheet is intended for quick reference only and should not be relied upon to contain detailed and full information. For detailed and full information see the relevant full data sheet, which is available on request via the local NXP Semiconductors sales office. In case of any inconsistency or conflict with the short data sheet, the full data sheet shall prevail.

**Product specification** — The information and data provided in a Product data sheet shall define the specification of the product as agreed between NXP Semiconductors and its customer, unless NXP Semiconductors and customer have explicitly agreed otherwise in writing. In no event however, shall an agreement be valid in which the NXP Semiconductors product is deemed to offer functions and qualities beyond those described in the Product data sheet.

### 14.3 Disclaimers

**Limited warranty and liability** — Information in this document is believed to be accurate and reliable. However, NXP Semiconductors does not give any representations or warranties, expressed or implied, as to the accuracy or completeness of such information and shall have no liability for the consequences of use of such information.

In no event shall NXP Semiconductors be liable for any indirect, incidental, punitive, special or consequential damages (including - without limitation - lost profits, lost savings, business interruption, costs related to the removal or replacement of any products or rework charges) whether or not such damages are based on tort (including negligence), warranty, breach of contract or any other legal theory.

Notwithstanding any damages that customer might incur for any reason whatsoever, NXP Semiconductors' aggregate and cumulative liability towards customer for the products described herein shall be limited in accordance with the *Terms and conditions of commercial sale* of NXP Semiconductors.

**Right to make changes** — NXP Semiconductors reserves the right to make changes to information published in this document, including without limitation specifications and product descriptions, at any time and without notice. This document supersedes and replaces all information supplied prior to the publication hereof.

**Suitability for use** — NXP Semiconductors products are not designed, authorized or warranted to be suitable for use in life support, life-critical or safety-critical systems or equipment, nor in applications where failure or

malfunction of an NXP Semiconductors product can reasonably be expected to result in personal injury, death or severe property or environmental damage. NXP Semiconductors accepts no liability for inclusion and/or use of NXP Semiconductors products in such equipment or applications and therefore such inclusion and/or use is at the customer's own risk.

**Applications** — Applications that are described herein for any of these products are for illustrative purposes only. NXP Semiconductors makes no representation or warranty that such applications will be suitable for the specified use without further testing or modification.

Customers are responsible for the design and operation of their applications and products using NXP Semiconductors products, and NXP Semiconductors accepts no liability for any assistance with applications or customer product design. It is customer's sole responsibility to determine whether the NXP Semiconductors product is suitable and fit for the customer's applications and products planned, as well as for the planned application and use of customer's third party customer(s). Customers should provide appropriate design and operating safeguards to minimize the risks associated with their applications and products.

NXP Semiconductors does not accept any liability related to any default, damage, costs or problem which is based on any weakness or default in the customer's applications or products, or the application or use by customer's third party customer(s). Customer is responsible for doing all necessary testing for the customer's applications and products using NXP Semiconductors products in order to avoid a default of the applications and the products or of the application or use by customer's third party customer(s). NXP does not accept any liability in this respect.

**Limiting values** — Stress above one or more limiting values (as defined in the Absolute Maximum Ratings System of IEC 60134) will cause permanent damage to the device. Limiting values are stress ratings only and (proper) operation of the device at these or any other conditions above those given in the Recommended operating conditions section (if present) or the Characteristics sections of this document is not warranted. Constant or repeated exposure to limiting values will permanently and irreversibly affect the quality and reliability of the device.

**Terms and conditions of commercial sale** — NXP Semiconductors products are sold subject to the general terms and conditions of commercial sale, as published at <http://www.nxp.com/profile/terms>, unless otherwise agreed in a valid written individual agreement. In case an individual agreement is concluded only the terms and conditions of the respective agreement shall apply. NXP Semiconductors hereby expressly objects to applying the customer's general terms and conditions with regard to the purchase of NXP Semiconductors products by customer.

**No offer to sell or license** — Nothing in this document may be interpreted or construed as an offer to sell products that is open for acceptance or the grant, conveyance or implication of any license under any copyrights, patents or other industrial or intellectual property rights.

**Export control** — This document as well as the item(s) described herein may be subject to export control regulations. Export might require a prior authorization from national authorities.

**Quick reference data** — The Quick reference data is an extract of the product data given in the Limiting values and Characteristics sections of this document, and as such is not complete, exhaustive or legally binding.

**Non-automotive qualified products** — Unless this data sheet expressly states that this specific NXP Semiconductors product is automotive qualified, the product is not suitable for automotive use. It is neither qualified nor tested in accordance with automotive testing or application requirements. NXP Semiconductors accepts no liability for inclusion and/or use of non-automotive qualified products in automotive equipment or applications.

In the event that customer uses the product for design-in and use in automotive applications to automotive specifications and standards, customer (a) shall use the product without NXP Semiconductors' warranty of the

product for such automotive applications, use and specifications, and (b) whenever customer uses the product for automotive applications beyond NXP Semiconductors' specifications such use shall be solely at customer's own risk, and (c) customer fully indemnifies NXP Semiconductors for any liability, damages or failed product claims resulting from customer design and use of the product for automotive applications beyond NXP Semiconductors' standard warranty and NXP Semiconductors' product specifications.

## 14.4 Trademarks

Notice: All referenced brands, product names, service names and trademarks are the property of their respective owners.

## 15. Contact information

For more information, please visit: <http://www.nxp.com>

For sales office addresses, please send an email to: [salesaddresses@nxp.com](mailto:salesaddresses@nxp.com)

## 16. Contents

---

1	General description . . . . .	1
2	Features and benefits . . . . .	1
3	Applications . . . . .	1
4	Ordering information . . . . .	2
5	Functional diagram . . . . .	2
6	Pinning information . . . . .	3
6.1	Pinning . . . . .	3
6.2	Pin description . . . . .	3
7	Limiting values . . . . .	5
8	Recommended operating conditions . . . . .	5
9	Characteristics . . . . .	5
10	Application information . . . . .	7
11	Package outline . . . . .	10
12	Abbreviations . . . . .	11
13	Revision history . . . . .	12
14	Legal information . . . . .	13
14.1	Data sheet status . . . . .	13
14.2	Definitions . . . . .	13
14.3	Disclaimers . . . . .	13
14.4	Trademarks . . . . .	14
15	Contact information . . . . .	14
16	Contents . . . . .	15

---

Please be aware that important notices concerning this document and the product(s) described herein, have been included in section 'Legal information'.

---

© NXP B.V. 2011.

All rights reserved.

For more information, please visit: <http://www.nxp.com>

For sales office addresses, please send an email to: [salesaddresses@nxp.com](mailto:salesaddresses@nxp.com)

Date of release: 7 January 2011

Document identifier: IP4776CZ38