

# INA134 INA2134

## AUDIO DIFFERENTIAL LINE RECEIVERS 0dB (G = 1)

### FEATURES

- SINGLE AND DUAL VERSIONS
- LOW DISTORTION: 0.0005% at  $f = 1\text{kHz}$
- HIGH SLEW RATE:  $14\text{V}/\mu\text{s}$
- FAST SETTLING TIME:  $3\mu\text{s}$  to  $0.01\%$
- WIDE SUPPLY RANGE:  $\pm 4\text{V}$  to  $\pm 18\text{V}$
- LOW QUIESCIENT CURRENT:  $2.9\text{mA}$  max
- HIGH CMRR: 90dB
- FIXED GAIN = 0dB (1V/V)
- PACKAGES—SINGLE: 8-PIN DIP, SO-8  
DUAL: 14-PIN DIP, SO-14

### DESCRIPTION

The INA134 and INA2134 are differential line receivers consisting of high performance op amps with on-chip precision resistors. They are fully specified for high performance audio applications and have excellent ac specifications, including low distortion (0.0005% at 1kHz) and high slew rate ( $14\text{V}/\mu\text{s}$ ), assuring good dynamic response. In addition, wide output voltage swing and high output drive capability allow use in a wide variety of demanding applications. The dual version features completely independent circuitry for lowest crosstalk and freedom from interaction, even when overdriven or overloaded.

The INA134 and INA2134 on-chip resistors are laser trimmed for accurate gain and optimum common-mode rejection. Furthermore, excellent TCR tracking of the resistors maintains gain accuracy and common-mode rejection over temperature. Operation is guaranteed from  $\pm 4\text{V}$  to  $\pm 18\text{V}$  (8V to 36V total supply).

The INA134 is available in 8-pin DIP and SO-8 surface-mount packages. The INA2134 comes in 14-pin DIP and SO-14 surface-mount packages. Both are specified for operation over the extended industrial temperature range,  $-40^\circ\text{C}$  to  $+85^\circ\text{C}$ .

### APPLICATIONS

- AUDIO DIFFERENTIAL LINE RECEIVER
- SUMMING AMPLIFIER
- UNITY-GAIN INVERTING AMPLIFIER
- PSEUDOGROUND GENERATOR
- INSTRUMENTATION BUILDING BLOCK
- CURRENT SHUNT MONITOR
- VOLTAGE-CONTROLLED CURRENT SOURCE
- GROUND LOOP ELIMINATOR

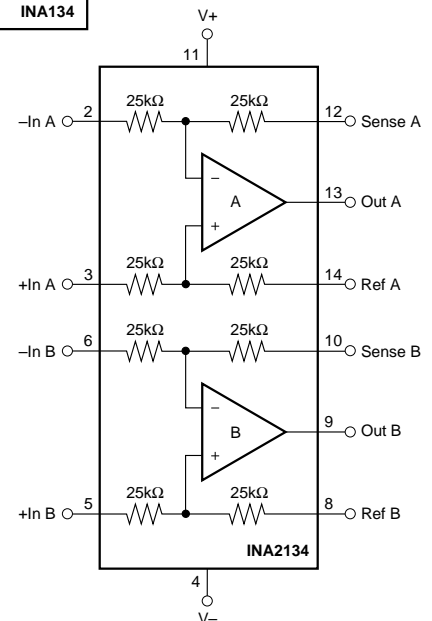
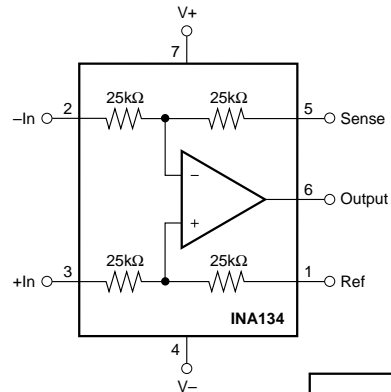

# SPECIFICATIONS: $V_S = \pm 18V$

At  $T_A = +25^\circ C$ ,  $V_S = \pm 18V$ ,  $R_L = 2k\Omega$ , and Ref Pin connected to Ground, unless otherwise noted.

PARAMETER	CONDITIONS	INA134PA, UA INA2134PA, UA			UNITS
		MIN	TYP	MAX	
<b>AUDIO PERFORMANCE</b> Total Harmonic Distortion + Noise, $f = 1kHz$ Noise Floor <sup>(1)</sup> Headroom <sup>(1)</sup>	$V_{IN} = 10V_{rms}$ 20kHz BW THD+N < 1%		0.0005 -100 +23		% dBu dBu
<b>FREQUENCY RESPONSE</b> Small-Signal Bandwidth Slew Rate Settling Time: 0.1% 0.01% Overload Recovery Time Channel Separation (dual), $f = 1kHz$	10V Step, $C_L = 100pF$ 10V Step, $C_L = 100pF$ 50% Overdrive		3.1 14 2 3 3 117		MHz V/ $\mu s$ $\mu s$ $\mu s$ $\mu s$ dB
<b>OUTPUT NOISE VOLTAGE<sup>(2)</sup></b> $f = 20Hz$ to 20kHz $f = 1kHz$			7 52		$\mu V_{rms}$ nV/ $\sqrt{Hz}$
<b>OFFSET VOLTAGE<sup>(3)</sup></b> Input Offset Voltage vs Temperature vs Power Supply	$V_{CM} = 0V$ Specified Temperature Range $V_S = \pm 4V$ to $\pm 18V$		$\pm 100$ $\pm 2$ $\pm 5$	$\pm 1000$  $\pm 60$	$\mu V$ $\mu V/^\circ C$ $\mu V/V$
<b>INPUT</b> Common-Mode Voltage Range: Positive Negative Differential Voltage Range Common-Mode Rejection Impedance <sup>(4)</sup> Differential Common-Mode	$V_O = 0V$ $V_O = 0V$  $V_{CM} = \pm 31V$ , $R_S = 0\Omega$	2(V+)-5 2(V-)+5  74	2(V+)-4 2(V-)+2 See Typical Curve 90 50 50		V V dB k $\Omega$ k $\Omega$
<b>GAIN</b> Initial Error vs Temperature Nonlinearity	$V_O = -16V$ to 16V  $V_O = -16V$ to 16V		1 $\pm 0.02$ $\pm 1$ 0.0001	$\pm 0.1$  $\pm 10$	V/V % ppm/ $^\circ C$ %
<b>OUTPUT</b> Voltage Output, Positive Negative Current Limit, Continuous to Common Capacitive Load (Stable Operation)		(V+)-2 (V-)+2	(V+)-1.8 (V-)+1.6 $\pm 60$ 500		V V mA pF
<b>POWER SUPPLY</b> Rated Voltage Voltage Range Quiescent Current (per Amplifier)	$I_O = 0$	$\pm 4$	$\pm 18$  $\pm 2.4$	$\pm 18$  $\pm 2.9$	V V mA
<b>TEMPERATURE RANGE</b> Specification Range Operation Range Storage Range Thermal Resistance, $\theta_{JA}$ 8-Pin DIP SO-8 Surface-Mount 14-Pin DIP SO-14 Surface-Mount		-40 -55 -55		85 125 125	$^\circ C$ $^\circ C$ $^\circ C$ $^\circ C/W$ $^\circ C/W$ $^\circ C/W$ $^\circ C/W$

NOTES: (1) dBu = 20log (Vrms/0.7746). (2) Includes effects of amplifier's input current noise and thermal noise contribution of resistor network. (3) Includes effects of amplifier's input bias and offset currents. (4) 25k $\Omega$  resistors are ratio matched but have  $\pm 25\%$  absolute value.

The information provided herein is believed to be reliable; however, BURR-BROWN assumes no responsibility for inaccuracies or omissions. BURR-BROWN assumes no responsibility for the use of this information, and all use of such information shall be entirely at the user's own risk. Prices and specifications are subject to change without notice. No patent rights or licenses to any of the circuits described herein are implied or granted to any third party. BURR-BROWN does not authorize or warrant any BURR-BROWN product for use in life support devices and/or systems.

## PIN CONFIGURATIONS

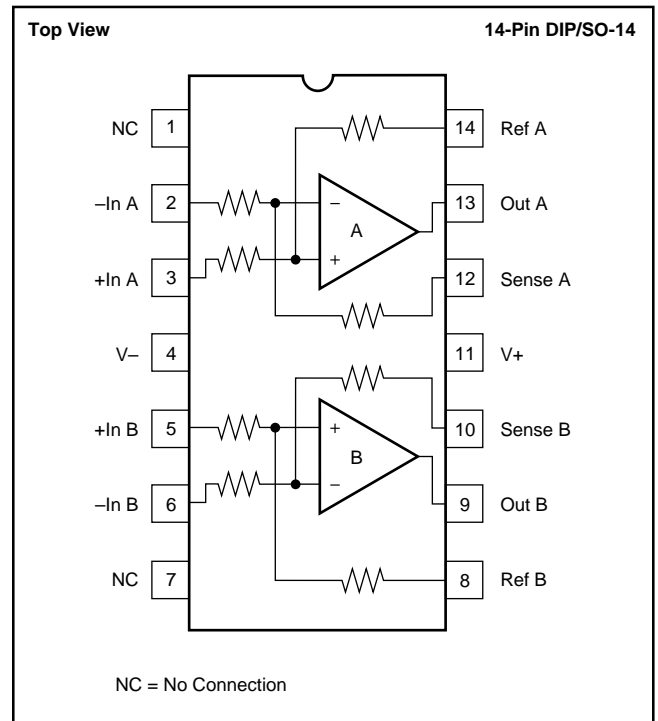
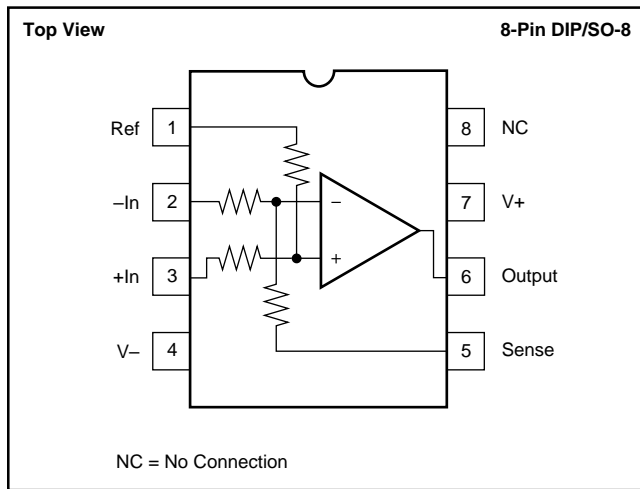

## ABSOLUTE MAXIMUM RATINGS<sup>(1)</sup>

Supply Voltage, V+ to V-	40V
Input Voltage Range	±80V
Output Short-Circuit (to ground) <sup>(2)</sup>	Continuous
Operating Temperature	-55°C to +125°C
Storage Temperature	-55°C to +125°C
Junction Temperature	+150°C
Lead Temperature (soldering, 10s)	+300°C

NOTE: (1) Stresses above these ratings may cause permanent damage.  
 (2) One channel per package.

## PACKAGE/ORDERING INFORMATION

PRODUCT	PACKAGE	PACKAGE DRAWING NUMBER <sup>(1)</sup>	SPECIFICATION TEMPERATURE RANGE
<b>Single</b>			
INA134PA	8-Pin DIP	006	-40°C to +85°C
INA134UA	SO-8 Surface-Mount	182	-40°C to +85°C
<b>Dual</b>			
INA2134PA	14-Pin DIP	010	-40°C to +85°C
INA2134UA	SO-14 Surface-Mount	235	-40°C to +85°C

NOTE: (1) For detailed drawing and dimension table, please see end of data sheet, or Appendix C of Burr-Brown IC Data Book.



## ELECTROSTATIC DISCHARGE SENSITIVITY

This integrated circuit can be damaged by ESD. Burr-Brown recommends that all integrated circuits be handled with appropriate precautions. Failure to observe proper handling and installation procedures can cause damage.

ESD damage can range from subtle performance degradation to complete device failure. Precision integrated circuits may be more susceptible to damage because very small parametric changes could cause the device not to meet its published specifications.

# TYPICAL PERFORMANCE CURVES

At  $T_A = +25^\circ\text{C}$ ,  $V_S = \pm 18\text{V}$ , unless otherwise noted.

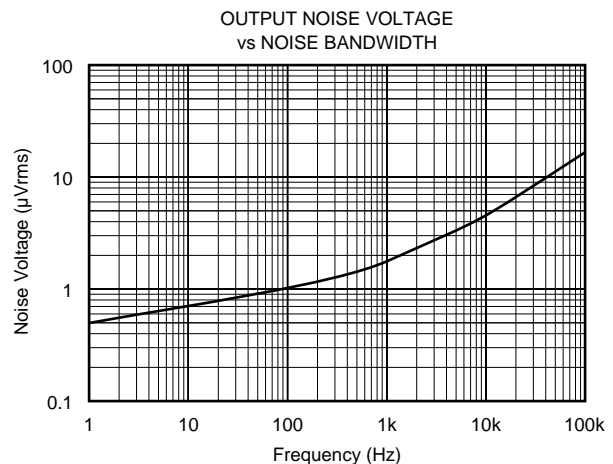
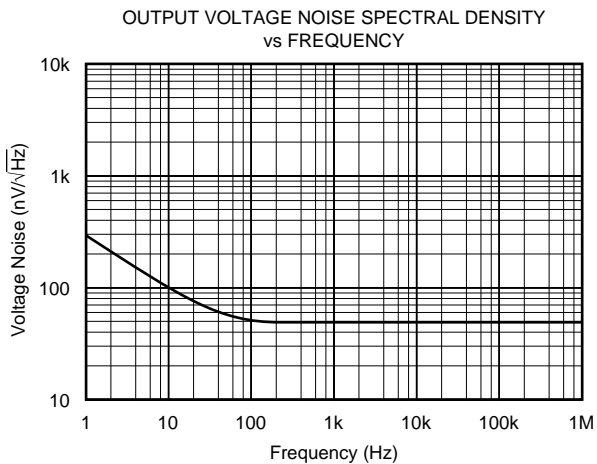
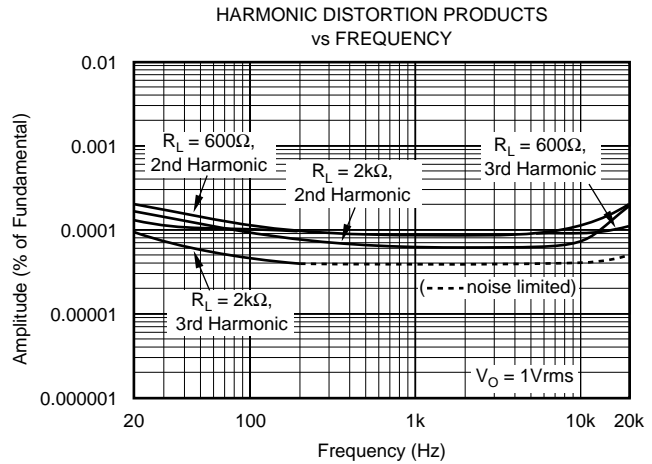
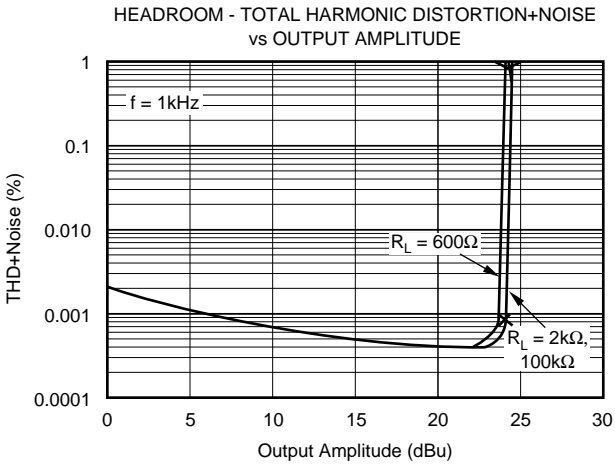
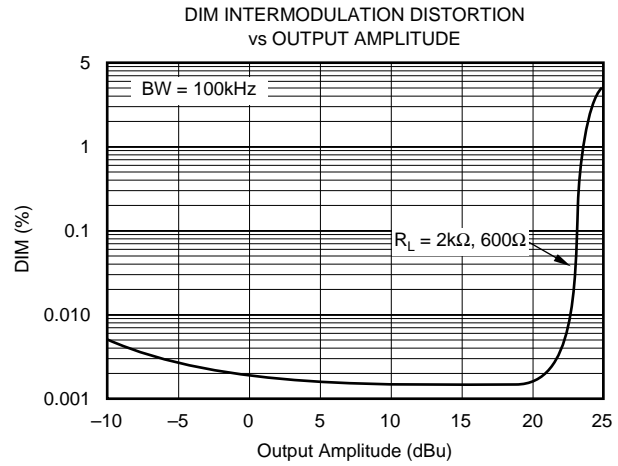
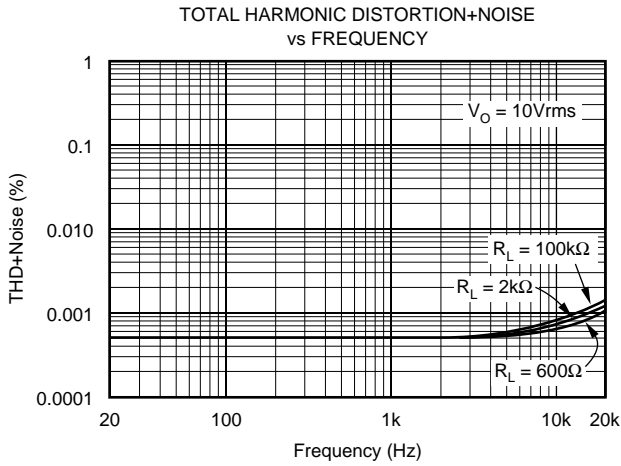

# TYPICAL PERFORMANCE CURVES (CONT)

At  $T_A = +25^\circ\text{C}$ ,  $V_S = \pm 18\text{V}$ , unless otherwise noted.

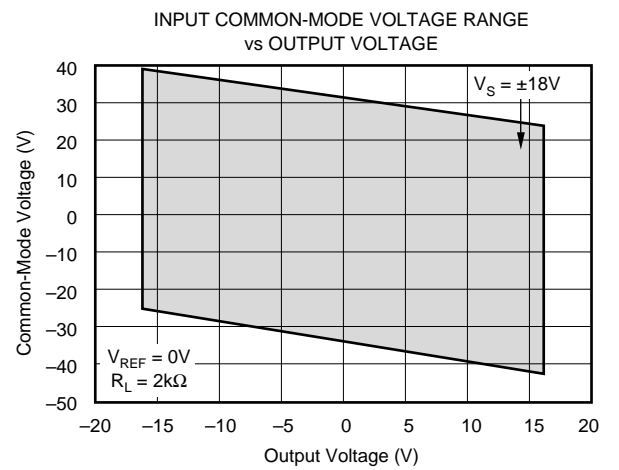
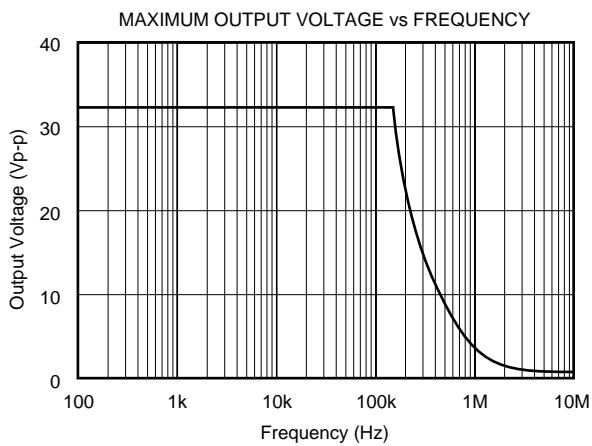
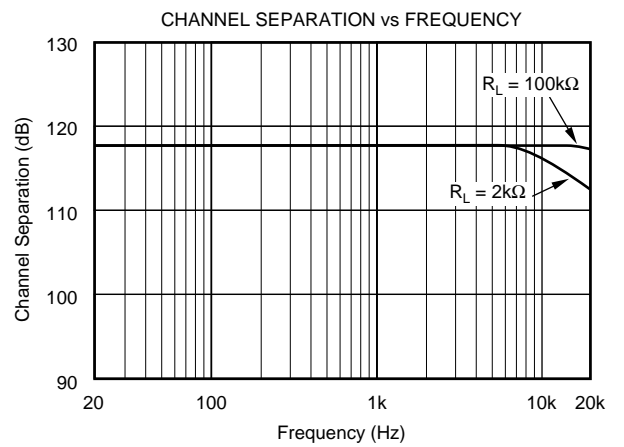
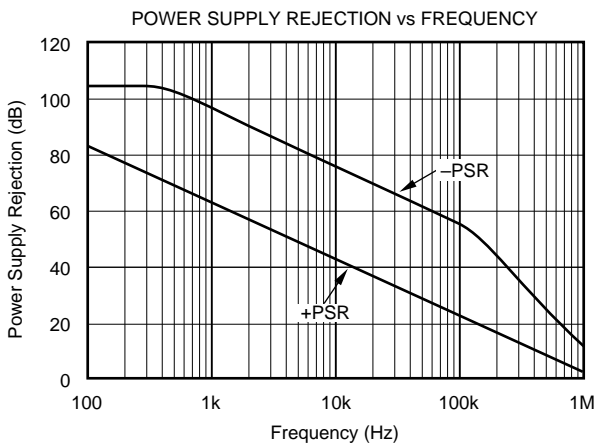
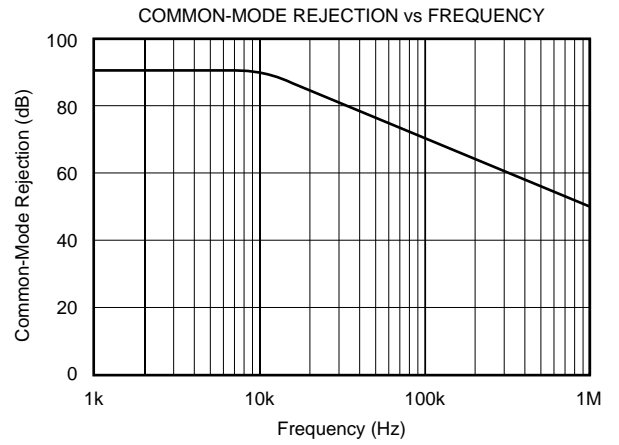
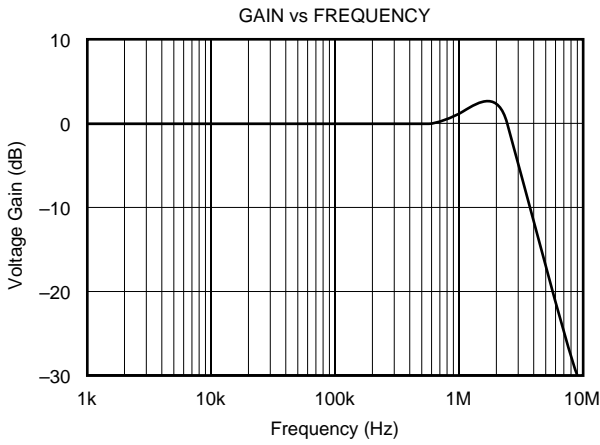

# TYPICAL PERFORMANCE CURVES (CONT)

At  $T_A = +25^\circ\text{C}$ ,  $V_S = \pm 18\text{V}$ , unless otherwise noted.

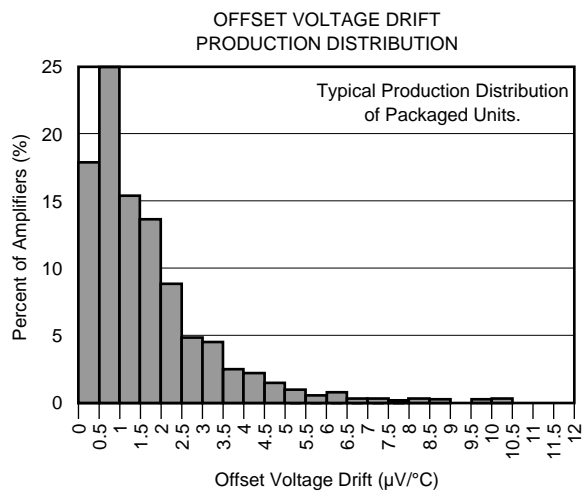
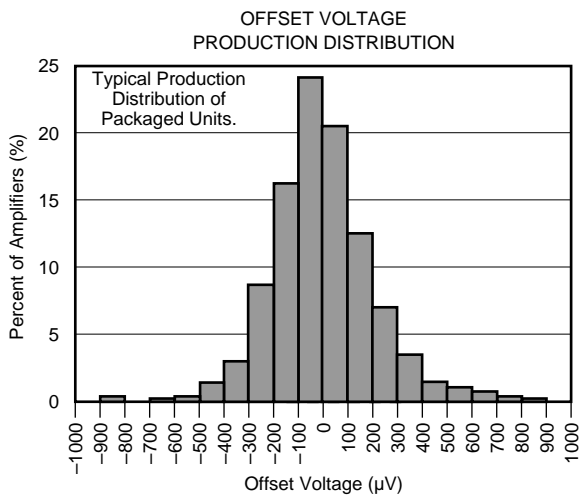
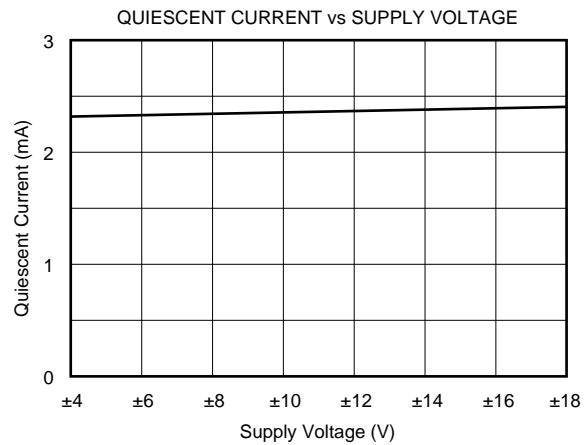
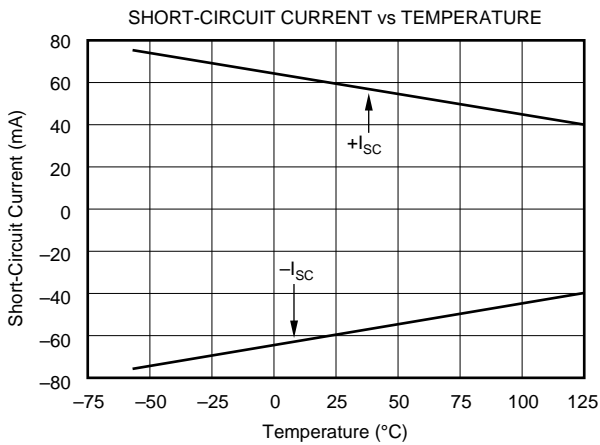
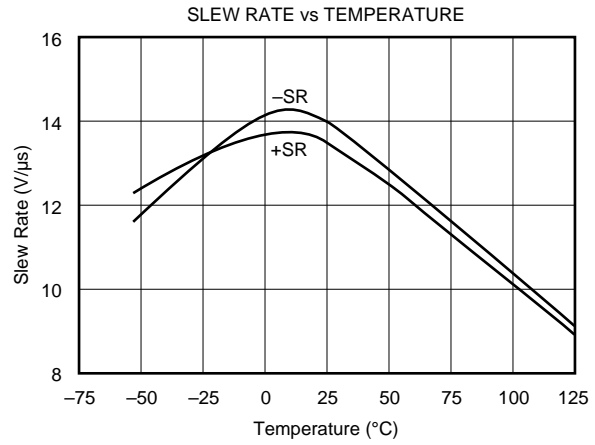
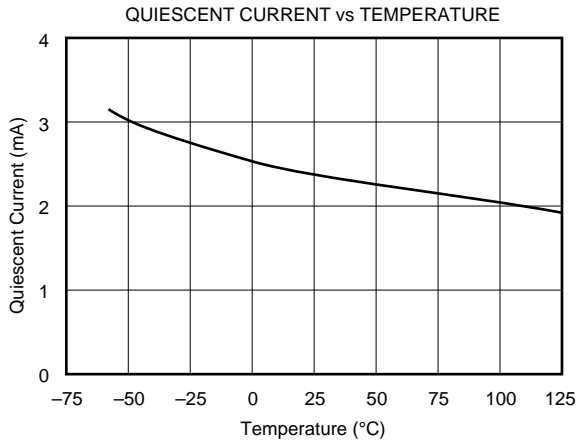

# TYPICAL PERFORMANCE CURVES (CONT)

At  $T_A = +25^\circ\text{C}$ ,  $V_S = \pm 18\text{V}$ , unless otherwise noted.

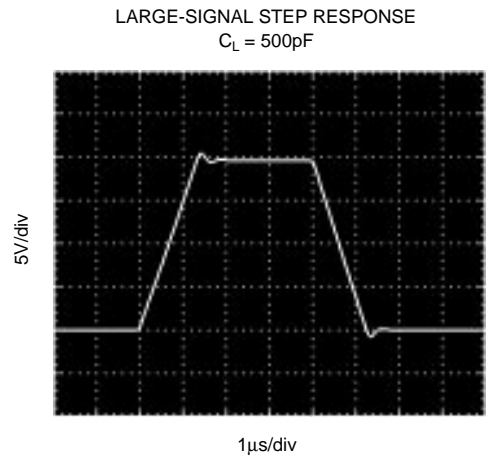
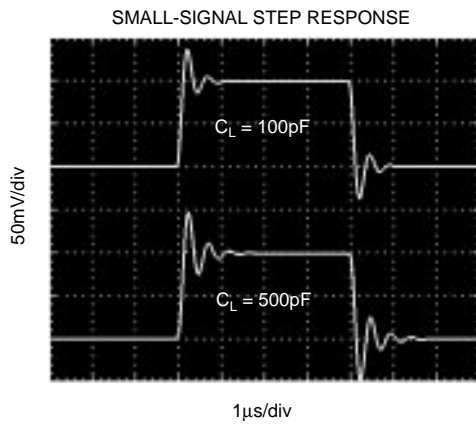
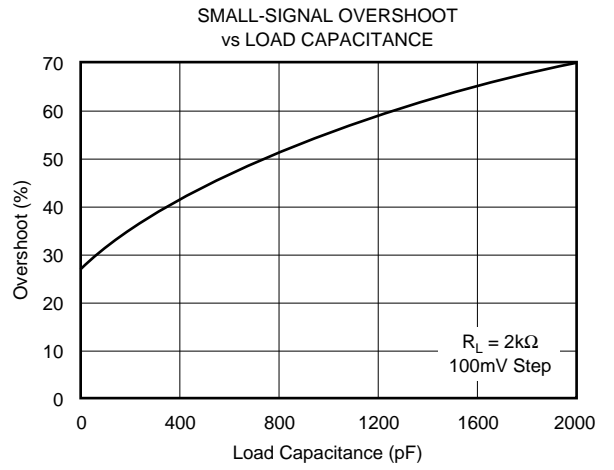
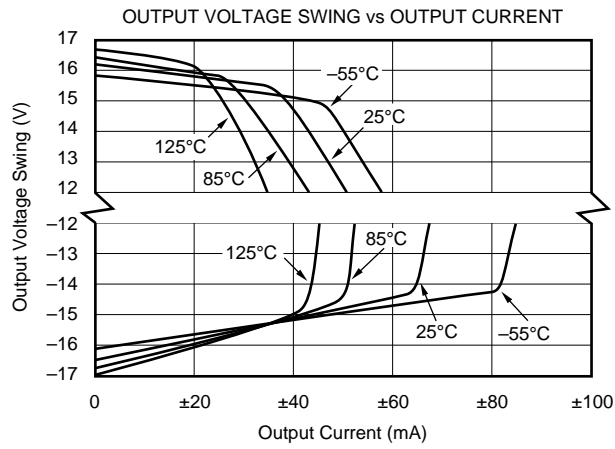

# APPLICATIONS INFORMATION

Figure 1 shows the basic connections required for operation of the INA134. Decoupling capacitors are strongly recommended in applications with noisy or high impedance power supplies. The capacitors should be placed close to the device pins as shown in Figure 1. All circuitry is completely independent in the dual version assuring lowest crosstalk and normal behavior when one amplifier is overdriven or short-circuited.

As shown in Figure 1, the differential input signal is connected to pins 2 and 3. The source impedances connected to the inputs must be nearly equal to assure good common-mode rejection. A 10Ω mismatch in source impedance will degrade the common-mode rejection of a typical device to approximately 74dB. If the source has a known impedance mismatch, an additional resistor in series with the opposite input can be used to preserve good common-mode rejection.

Do not interchange pins 1 and 3 or pins 2 and 5, even though nominal resistor values are equal. These resistors are laser trimmed for precise resistor ratios to achieve accurate gain and highest CMR. Interchanging these pins would not provide specified performance.

## AUDIO PERFORMANCE

The INA134 and INA2134 were designed for enhanced ac performance. Very low distortion, low noise, and wide bandwidth provide superior performance in high quality audio applications. Laser-trimmed matched resistors provide optimum common-mode rejection (typically 90dB), especially when compared to circuits implemented with an op amp and discrete precision resistors. In addition, high slew rate (14V/μs) and fast settling time (3μs to 0.01%) ensure good dynamic performance.

The INA134 and INA2134 have excellent distortion characteristics. THD+Noise is below 0.002% throughout the audio frequency range. Up to approximately 10kHz distortion is below the measurement limit of commonly used test equipment. Furthermore, distortion remains relatively flat over its wide output voltage swing range (approximately 1.7V from either supply).

## OFFSET VOLTAGE TRIM

The INA134 and INA2134 are laser trimmed for low offset voltage and drift. Most applications require no external offset adjustment. Figure 2 shows an optional circuit for trimming the output offset voltage. The output is referred to the output reference terminal (pin 1), which is normally grounded. A voltage applied to the Ref terminal will be summed with the output signal. This can be used to null offset voltage as shown in Figure 2. The source impedance of a signal applied to the Ref terminal should be less than 10Ω to maintain good common-mode rejection.

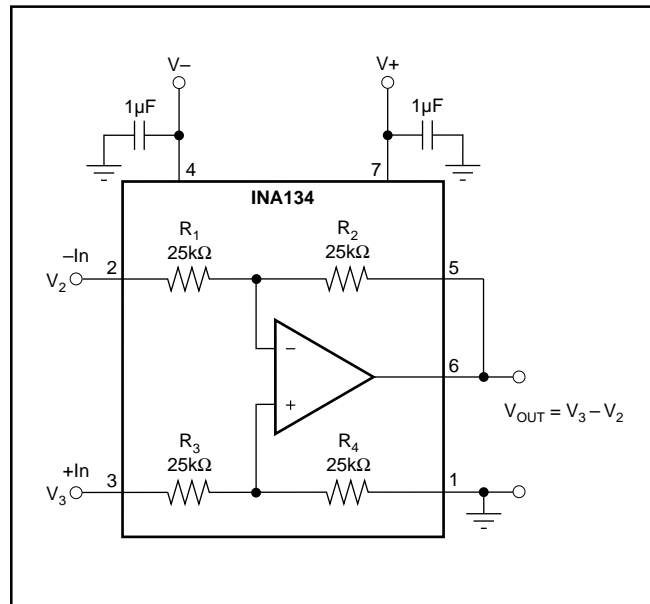

FIGURE 1. Precision Difference Amplifier (Basic Power Supply and Signal Connections).

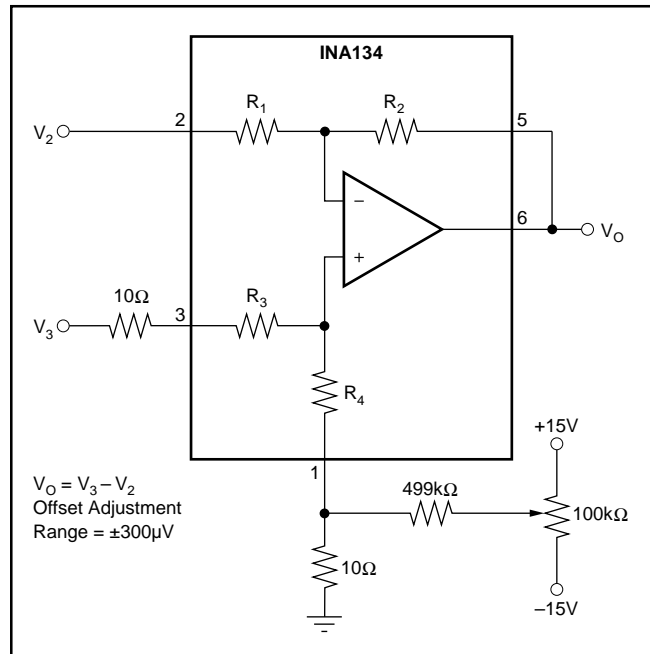

FIGURE 2. Offset Adjustment.



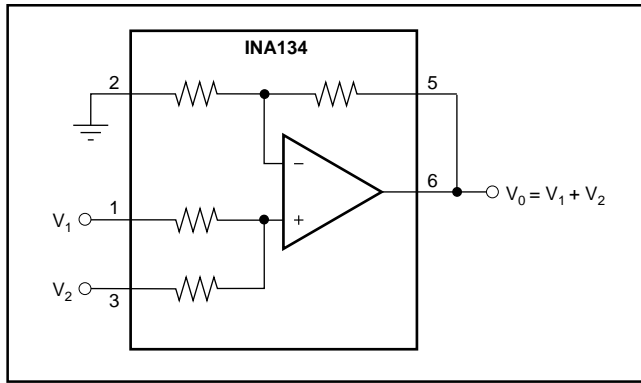

FIGURE 3. Precision Summing Amplifier.

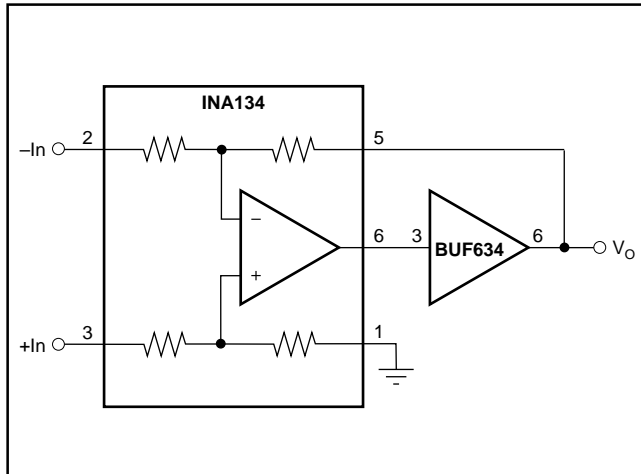

FIGURE 4. Boosting Output Current.

The difference amplifier is a highly versatile building block that is useful in a wide variety of applications. See the INA105 data sheet for additional applications ideas, including:

- Current Receiver with Compliance to Rails
- Precision Unity-Gain Inverting Amplifier
- $\pm 10\text{V}$  Precision Voltage Reference
- $\pm 5\text{V}$  Precision Voltage Reference
- Precision Unity-Gain Buffer
- Precision Average Value Amplifier
- Precision  $G = 2$  Amplifier
- Precision Summing Amplifier
- Precision  $G = 1/2$  Amplifier
- Precision Bipolar Offsetting
- Precision Summing Amplifier with Gain
- Instrumentation Amplifier Guard Drive Generator

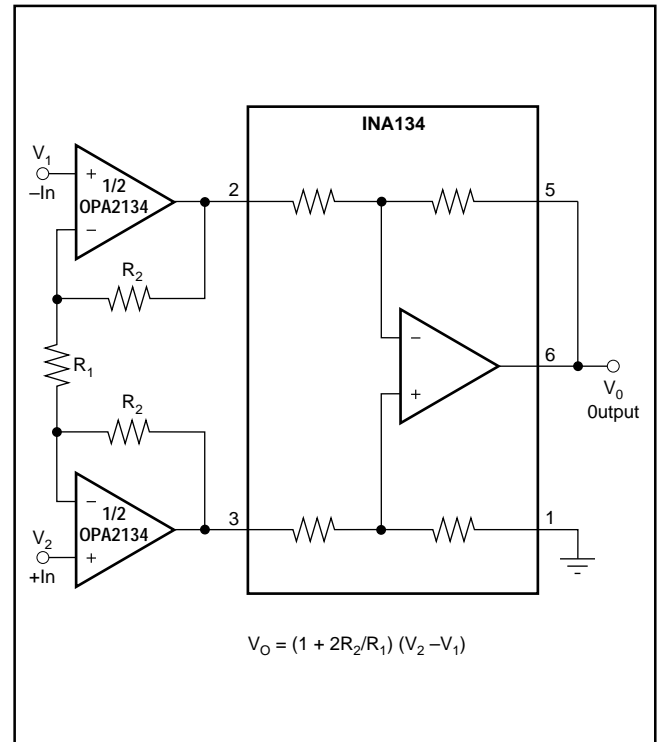

FIGURE 5. High Input Impedance Instrumentation Amplifier.

- Precision Summing Instrumentation Amplifier
- Precision Absolute Value Buffer
- Precision Voltage-to-Current Converter with Differential Inputs
- Differential Input Voltage-to-Current Converter for Low  $I_{OUT}$
- Isolating Current Source
- Differential Output Difference Amplifier
- Isolating Current Source with Buffering Amplifier for Greater Accuracy
- Window Comparator with Window Span and Window Center Inputs
- Precision Voltage-Controlled Current Source with Buffered Differential Inputs and Gain
- Digitally Controlled Gain of  $\pm 1$  Amplifier