



www.ti.com

# Single-Supply DIFFERENCE AMPLIFIER

## FEATURES

- SWING: to Within 200mV of Either Output Rail
- LOW OFFSET DRIFT:  $\pm 3\mu\text{V}/^\circ\text{C}$
- LOW OFFSET VOLTAGE:  $\pm 250\mu\text{V}$
- HIGH CMR: 94dB
- LOW GAIN ERROR: 0.01%
- LOW GAIN ERROR DRIFT: 1ppm/ $^\circ\text{C}$
- WIDE SUPPLY RANGE:  
Single: 2.7V to 20V  
Dual:  $\pm 1.35\text{V}$  to  $\pm 10\text{V}$
- MSOP-8 PACKAGE

## APPLICATIONS

- DIFFERENCE INPUT AMPLIFIER BUILDING BLOCK
- UNITY-GAIN INVERTING AMPLIFIER
- GAIN = 1/2
- AMPLIFIER GAIN = 2 AMPLIFIER
- SUMMING AMPLIFIER
- SYNCHRONOUS DEMODULATOR
- CURRENT AND DIFFERENTIAL LINE RECEIVER
- VOLTAGE-CONTROLLED CURRENT SOURCE
- BATTERY-POWERED SYSTEMS
- LOW-COST AUTOMOTIVE INSTRUMENTATION

## DESCRIPTION

The INA152 is a small (MSOP-8), low-power, unity-gain difference amplifier consisting of a CMOS op amp and a precision resistor network. The on-chip resistors are laser trimmed for accurate gain and high common-mode rejection. Excellent TCR tracking of the resistor maintains gain accuracy and common-mode rejection over temperature. The input common-mode voltage range extends to above the positive and

negative rails and the output swings to within 50mV of either rail.

The difference amplifier is the foundation of many commonly used circuits. The INA152 provides precision circuit function without using an expensive precision network.

The INA152 is specified for operation over the extended industrial temperature range,  $-40^\circ\text{C}$  to  $+85^\circ\text{C}$ .

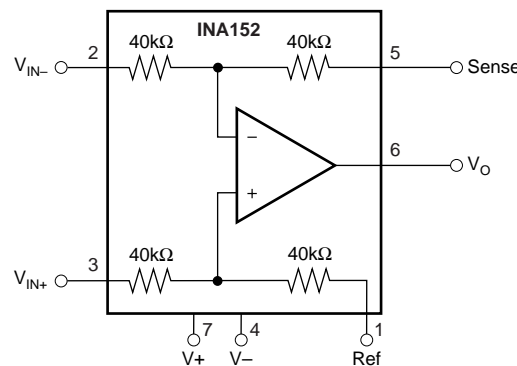

# SPECIFICATIONS: $V_S = \pm 10V$

$T_A = +25^\circ C$ ,  $V_S = \pm 10V$ ,  $R_L = 10k\Omega$  connected to ground, and reference pin connected to ground, unless otherwise noted.

PARAMETER	CONDITIONS	INA152EA			UNITS
		MIN	TYP	MAX	
<b>OFFSET VOLTAGE</b> Input Offset Voltage vs Temperature vs Power Supply vs Time	RTO <sup>(1)</sup> (2) $V_{CM} = 0V$ $T_A = -40^\circ C$ to $+85^\circ C$ $V_S = \pm 1.35V$ to $\pm 10V$		$\pm 250$ $\pm 3$ 5 0.5	$\pm 1500$ $\pm 15$ 30	$\mu V$ $\mu V/^\circ C$ $\mu V/V$ $\mu V/mo$
<b>INPUT VOLTAGE RANGE</b> <sup>(3)</sup> Common-Mode Voltage Range  Common-Mode Rejection	$V_{IN+} - V_{IN-} = 0V$	2(V-) 80	94	2(V+) - 2	V dB
<b>INPUT IMPEDANCE</b> <sup>(4)</sup> Differential Common-Mode			80 80		k $\Omega$ k $\Omega$
<b>OUTPUT NOISE VOLTAGE</b> <sup>(1)</sup> (5) $f_O = 10Hz$ $f_O = 1kHz$ $f_B = 0.1Hz$ to $10Hz$	RTO		97 87 2.4		$nV/\sqrt{Hz}$ $nV/\sqrt{Hz}$ $\mu Vp-p$
<b>GAIN</b> Initial <sup>(6)</sup> Gain Error Gain Temperature Drift Coefficient Nonlinearity	$(V-) + 0.3V < V_O < (V+) - 0.350V$		1 $\pm 0.01$ $\pm 1$ $\pm 0.002$	$\pm 0.1$ $\pm 10$ $\pm 0.005$	V/V % ppm/ $^\circ C$ % of FS
<b>FREQUENCY RESPONSE</b> Small Signal Slew Rate Settling Time, 0.1% , 0.01% Overload Recovery	9V Step 9V Step 50% Overdrive		800 0.4 23 25 5		kHz V/ $\mu s$ $\mu s$ $\mu s$ $\mu s$
<b>OUTPUT</b> Voltage  Load Capacitance Stability Short-Circuit Current	$R_L = 10k\Omega$ to GND  Continuous to Common	(V+) - 0.35 (V-) + 0.3	(V+) - 0.02 (V-) + 0.15 500 +7, -12		V V pF mA
<b>POWER SUPPLY</b> Rated Voltage Voltage Range  Current, Quiescent	$I_O = 0mA$	$\pm 1.35$ 2.7	$\pm 10$  500	$\pm 10$ 20 650	V V V $\mu A$
<b>TEMPERATURE RANGE</b> Specification Operating $\theta_{JA}$ , Junction to Ambient		-40 -55	150	+85 +125	$^\circ C$ $^\circ C$ $^\circ C/W$

NOTES: (1) Referred to output in unity-gain difference configuration. Note that this circuit has a gain of 2 for the op amp's offset voltage and noise voltage. (2) Includes effects of amplifier's input bias and offset currents. (3) Limit  $I_{IN}$  through  $40k\Omega$  resistors to 1mA. (4)  $40k\Omega$  resistors are ratio matched but have  $\pm 20\%$  absolute value. (5) Includes effects of amplifier's input current noise and thermal noise contribution of resistor network. (6) Connected as difference amplifier.

# SPECIFICATIONS: $V_S = +5V$

$T_A = +25^\circ\text{C}$ ,  $V_S = +5V$ , Ref connected to  $V_S/2$ ,  $R_L = 10k\Omega$  connected to  $V_S/2$ , unless otherwise noted.

PARAMETER	CONDITIONS	INA152EA			UNITS
		MIN	TYP	MAX	
<b>OFFSET VOLTAGE</b> Input Offset Voltage vs Temperature	RTO <sup>(1) (2)</sup> $V_{CM} = V_{OUT} = 0V$ $T_A = -40^\circ\text{C} \leq T_A \leq 85^\circ\text{C}$		$\pm 250$ $\pm 3$	$\pm 1500$ $\pm 15$	$\mu\text{V}$ $\mu\text{V}/^\circ\text{C}$
<b>INPUT VOLTAGE RANGE<sup>(3)</sup></b> Voltage Range, Common-Mode Common-Mode Rejection	$V_{IN+} - V_{IN-} = 0V$ $0V < V_{CM} < +5V$ , $R_{SRC} = 0\Omega$	-2.5 80	94	+5.5	V dB
<b>OUTPUT</b> Voltage	$R_L = 10k\Omega$ to GND	(V+) - 0.2 (V-) + 0.2	(V-) + 0.05		V V V

NOTES: (1) Referred to output in unity-gain difference configuration. Note that this circuit has a gain of 2 for the op amp's offset voltage and noise voltage. (2) Includes effects of amplifier's input bias and offset currents. (3) Limit  $I_{IN}$  through  $40k\Omega$  resistors to 1mA.

## PIN CONFIGURATION

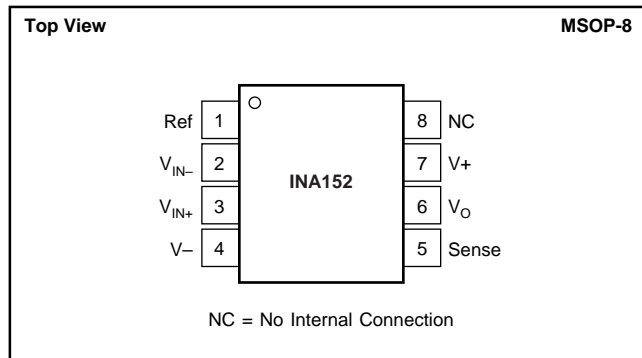

## ELECTROSTATIC DISCHARGE SENSITIVITY

This integrated circuit can be damaged by ESD. Burr-Brown recommends that all integrated circuits be handled with appropriate precautions. Failure to observe proper handling and installation procedures can cause damage.

ESD damage can range from subtle performance degradation to complete device failure. Precision integrated circuits may be more susceptible to damage because very small parametric changes could cause the device not to meet its published specifications.

## ABSOLUTE MAXIMUM RATINGS<sup>(1)</sup>

Supply Voltage, V+ to V-	+22V
Signal Input Terminals	+20V Continuous
Output Short-Circuit to GND Duration	Continuous
Operating Temperature	-55°C to +125°C
Storage Temperature	-55°C to +125°C
Junction Temperature	+150°C
Lead Temperature (soldering, 10s)	+300°C

## PACKAGE/ORDERING INFORMATION

PRODUCT	PACKAGE	PACKAGE DRAWING NUMBER	SPECIFIED TEMPERATURE RANGE	PACKAGE MARKING	ORDERING NUMBER <sup>(1)</sup>	TRANSPORT MEDIA
INA152EA	MSOP-8	337	-40°C to +85°C	B52	INA152EA/250	Tape and Reel
"	"	"	"	"	INA152EA/2K5	Tape and Reel

NOTE: (1) Models with a slash (/) are available only in Tape and Reel in the quantities indicated (e.g., /2K5 indicates 2500 devices per reel). Ordering 2500 pieces of "INA152EA/2K5" will get a single 2500-piece Tape and Reel.

# TYPICAL PERFORMANCE CURVES

At  $T_A = +25^\circ\text{C}$ ,  $V_S = \pm 10\text{V}$ ,  $R_L = 10\text{k}\Omega$  connected to GND, and Ref = GND, unless otherwise noted.

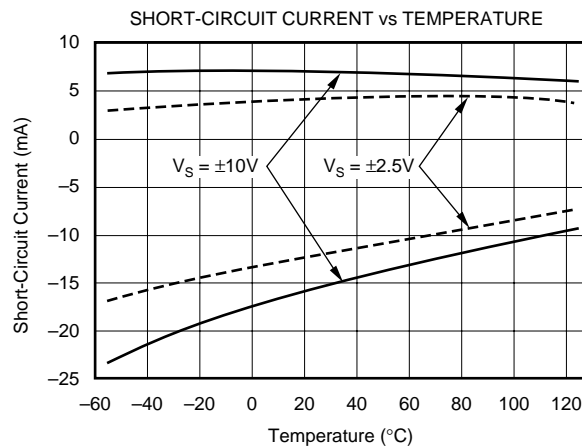
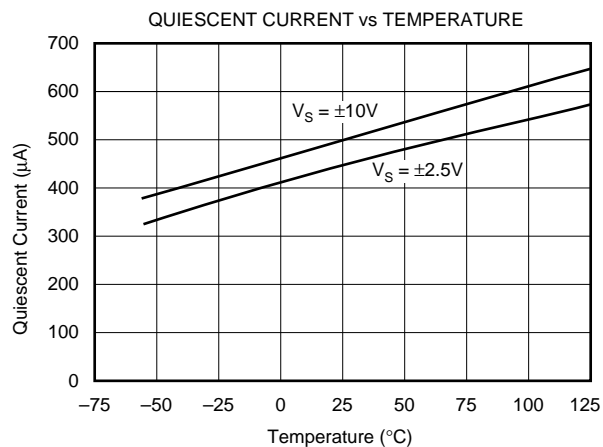
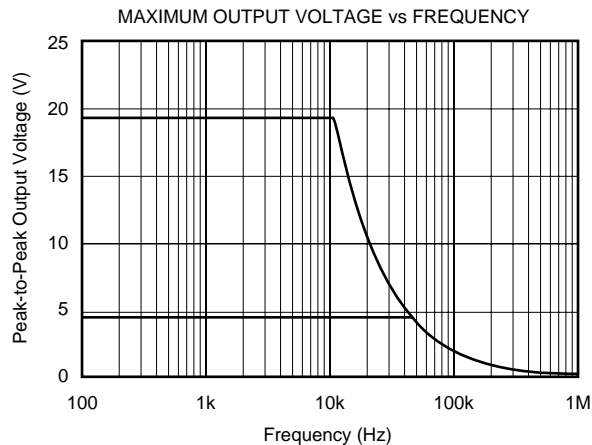
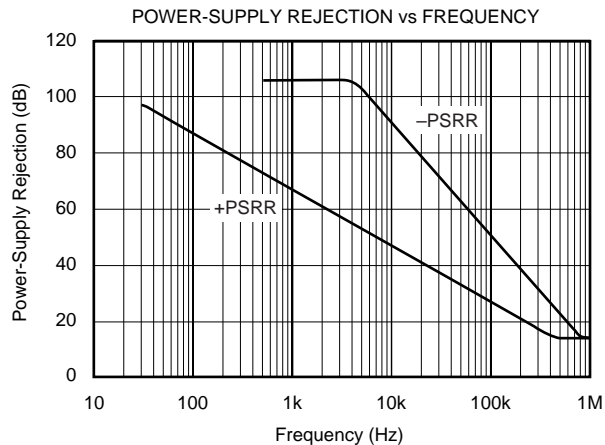
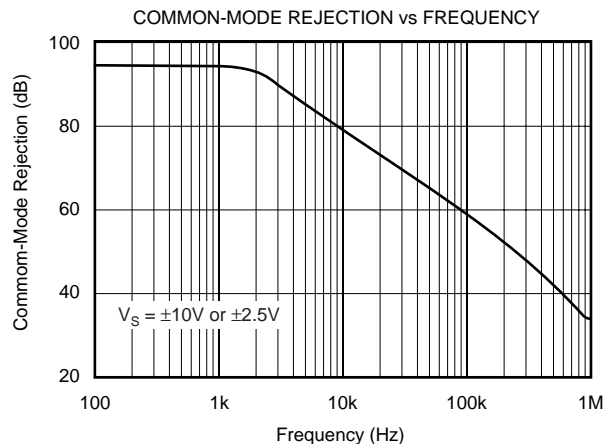
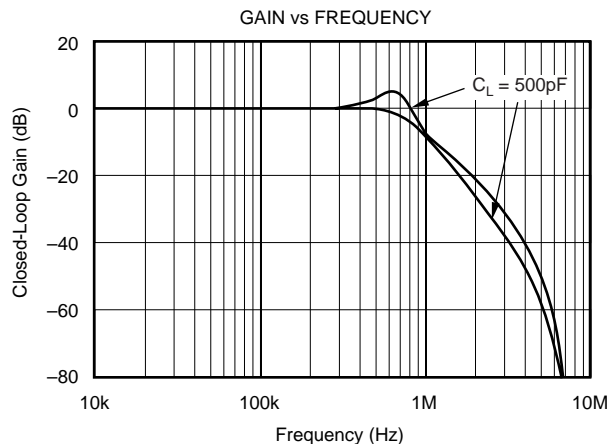

# TYPICAL PERFORMANCE CURVES (Cont.)

At  $T_A = +25^\circ\text{C}$ ,  $V_S = \pm 10\text{V}$ ,  $R_L = 10\text{k}\Omega$  connected to GND, and Ref = GND, unless otherwise noted.

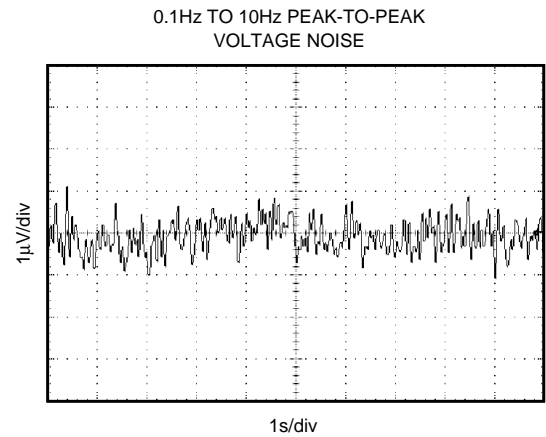
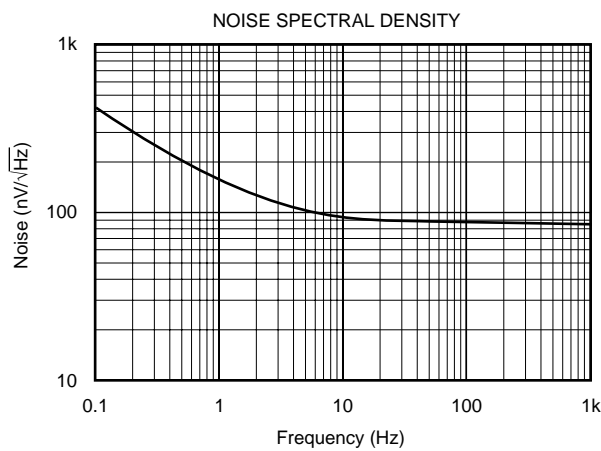
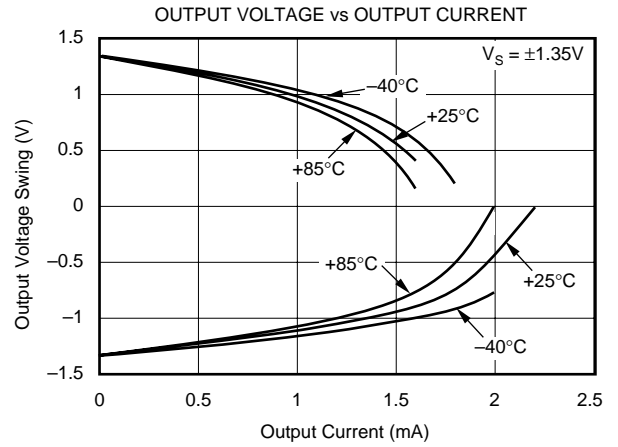
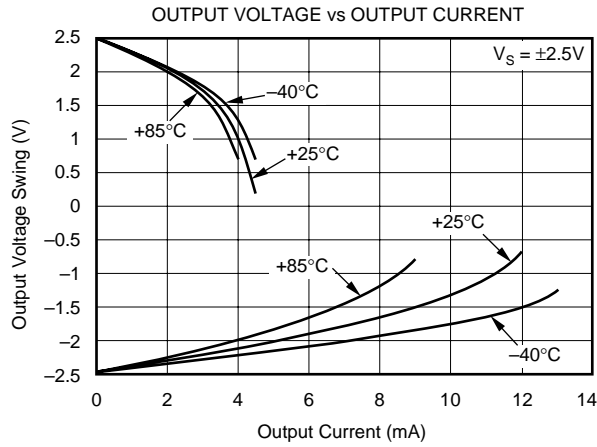
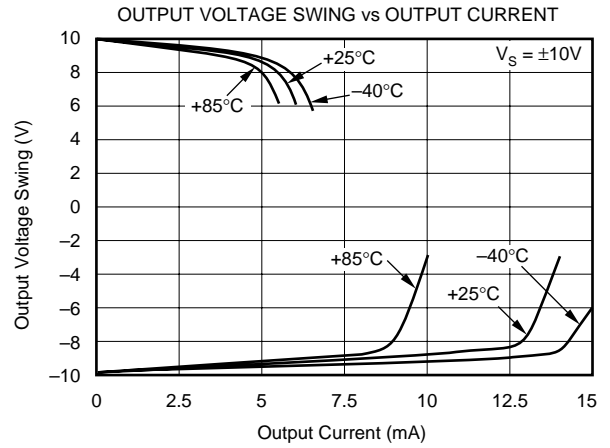
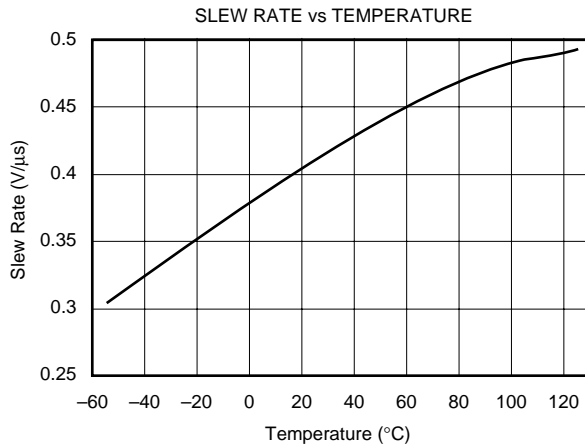

# TYPICAL PERFORMANCE CURVES (Cont.)

At  $T_A = +25^\circ\text{C}$ ,  $V_S = \pm 10\text{V}$ ,  $R_L = 10\text{k}\Omega$  connected to GND, and Ref = GND, unless otherwise noted.

SMALL-SIGNAL STEP RESPONSE

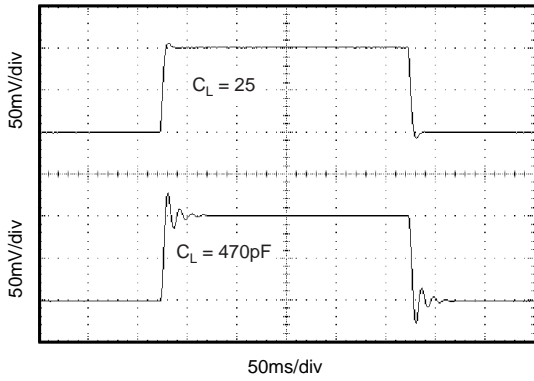

LARGE-SIGNAL STEP RESPONSE

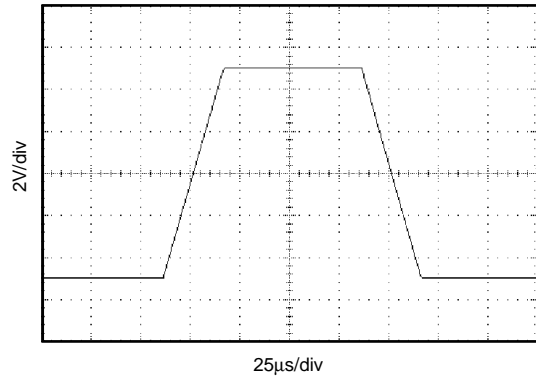

SETTLING TIME vs LOAD CAPACITANCE

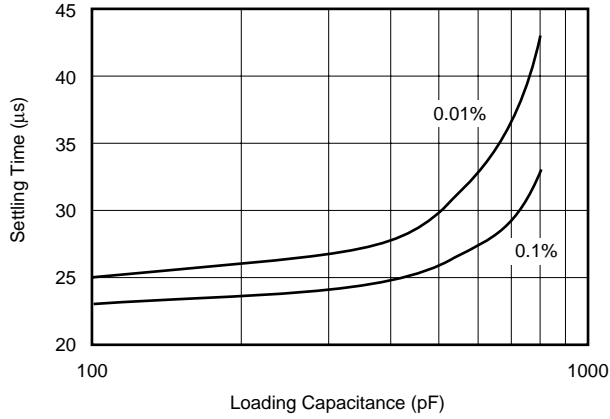

INPUT COMMON-MODE VOLTAGE vs OUTPUT VOLTAGE

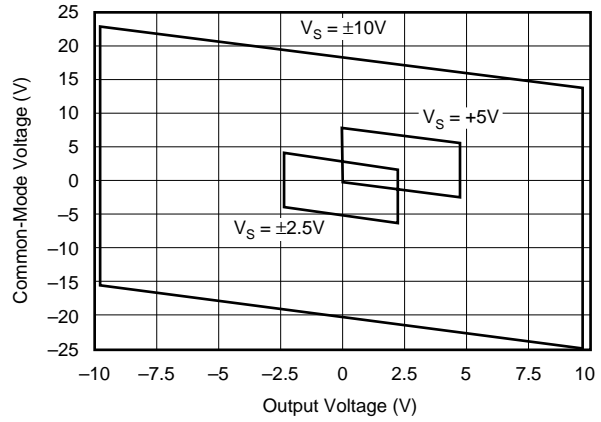

OFFSET VOLTAGE PRODUCTION DISTRIBUTION

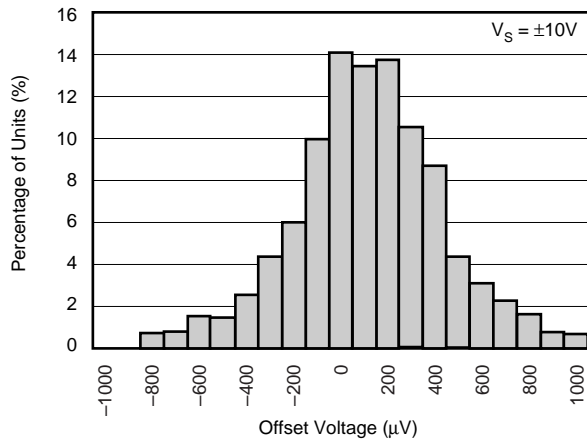

OFFSET VOLTAGE PRODUCTION DISTRIBUTION

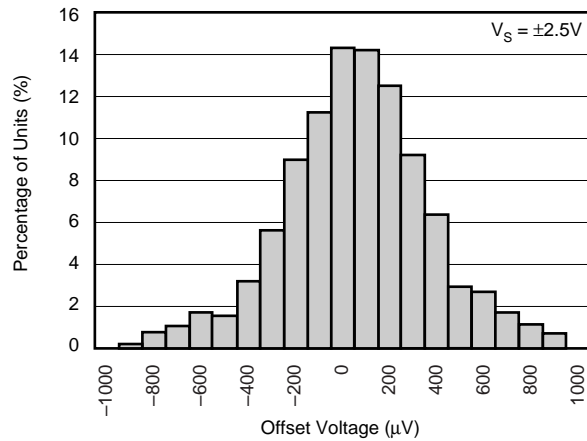

# TYPICAL PERFORMANCE CURVES (Cont.)

At  $T_A = +25^\circ\text{C}$ ,  $V_S = \pm 10\text{V}$ ,  $R_L = 10\text{k}\Omega$  connected to GND, and Ref = GND, unless otherwise noted.

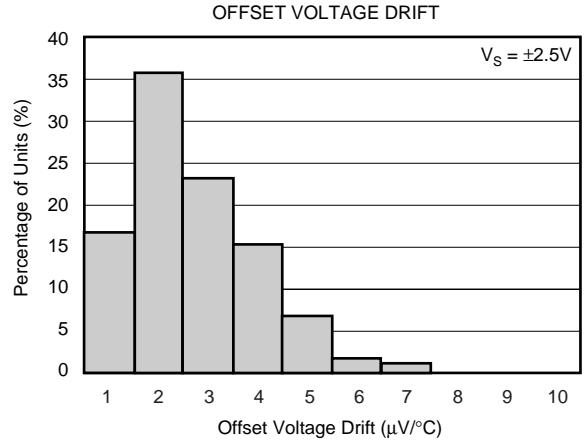
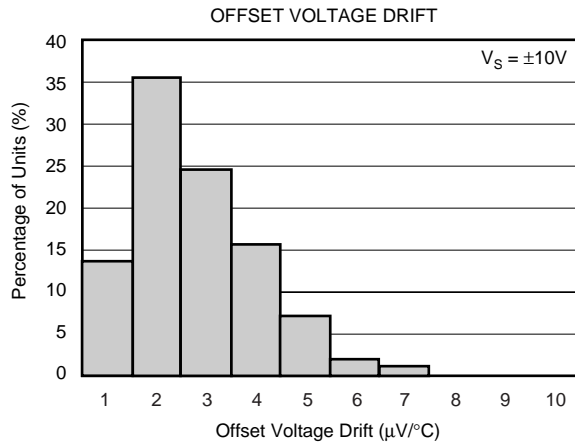

# APPLICATIONS INFORMATION

The INA152 is a low-power difference amplifier suitable for a wide range of general-purpose applications. Figure 1 shows the basic connections required for operation of the INA152. Decoupling capacitors are strongly recommended in applications with noisy or high-impedance power supplies. The capacitors should be placed close to the device pins, as shown in Figure 1.

As shown in Figure 1, the differential input signal is connected to pins 2 and 3. The source impedances connected to the inputs must be nearly equal to assure good common-mode rejection. An 8Ω mismatch in source impedance will degrade the common-mode rejection of a typical device to approximately 80dB (a 16Ω mismatch degrades CMR to 74dB). If the source has a known impedance mismatch, an additional resistor in series with the opposite input can be used to preserve good common-mode rejection.

The INA152's internal resistors are accurately ratio trimmed to match. That is,  $R_1$  is trimmed to match  $R_2$ , and  $R_3$  is trimmed to match  $R_4$ . However, the absolute values may not be equal ( $R_1 + R_2$  may be slightly different than  $R_3 + R_4$ ). Thus, large series resistors on the input (greater than 250Ω), even if well matched, will degrade common-mode rejection.

Circuit-board layout constraints might suggest possible variations in connections of the internal resistors. It might appear that pins 1 and 3 could be interchanged, however, because of the ratio trimming technique used (see paragraph above) CMRR will be degraded. If pins 1 and 3 are interchanged, pins 2 and 5 must also be interchanged to maintain proper ratio matching.

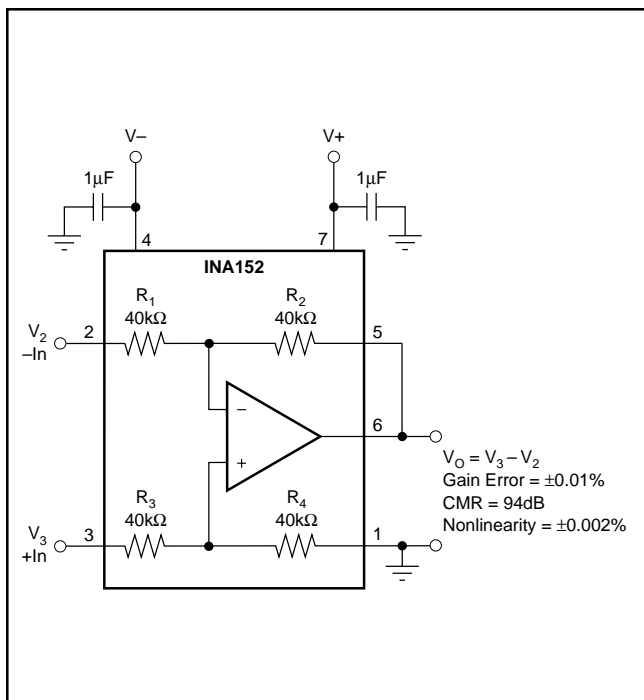

FIGURE 1. Precision Difference Amplifier (Basic Power Supply and Signal Connections).

# OPERATING VOLTAGE

The INA152 operates from single (+2.7V to +20V) or dual ( $\pm 1.35V$  to  $\pm 10V$ ) supplies with excellent performance. Specifications are production tested with +5V and  $\pm 10V$  supplies. Most behavior remains unchanged throughout the full operating voltage range. Parameters that vary significantly with operating voltage are shown in the typical performance curves.

# INPUT VOLTAGE

The INA152 can accurately measure differential signals that are above and below the supply rails. Linear common-mode range extends from  $2 \cdot [(V+) - 1V]$  to  $2 \cdot (V-)$  (nearly twice the supplies). See the typical performance curve, "Input Common-Mode Voltage vs Output Voltage".

# OFFSET VOLTAGE TRIM

The INA152 is laser trimmed for low offset voltage and drift. Most applications require no external offset adjustment. Figure 2 shows an optional circuit for trimming the output offset voltage. The output is referred to the output reference terminal (pin 1), which is normally grounded. A voltage applied to the Ref terminal will be summed with the output signal. This can be used to null offset voltage, as shown in Figure 2. The source impedance of a signal applied to the Ref terminal should be less than 10Ω to maintain good common-mode rejection.

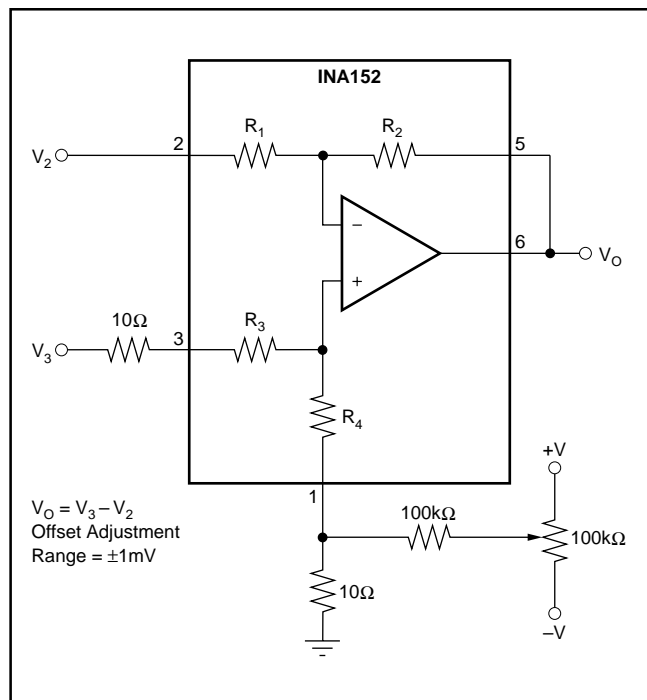

FIGURE 2. Offset Adjustment.



# TYPICAL APPLICATIONS

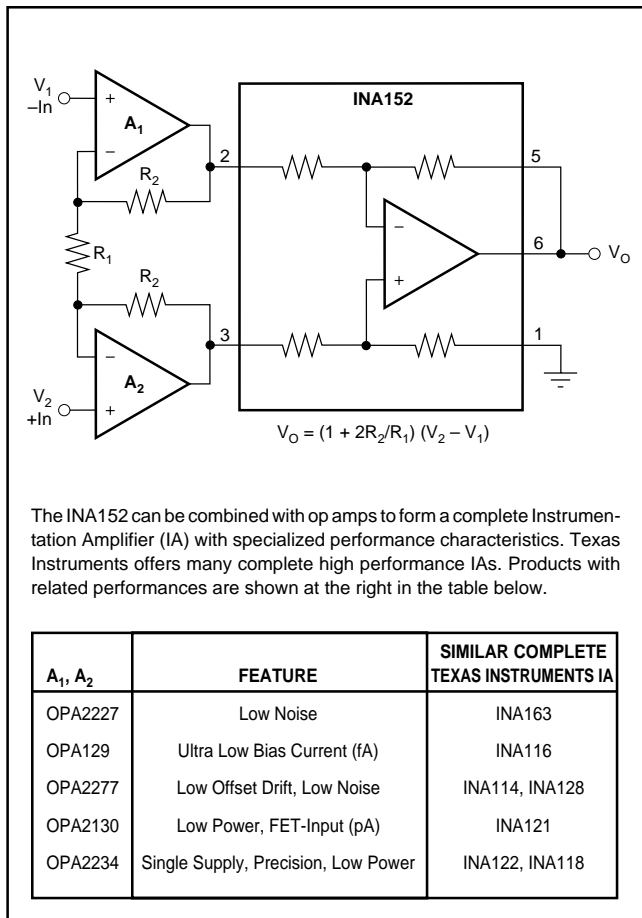

FIGURE 3. Precision Instrumentation Amplifier.

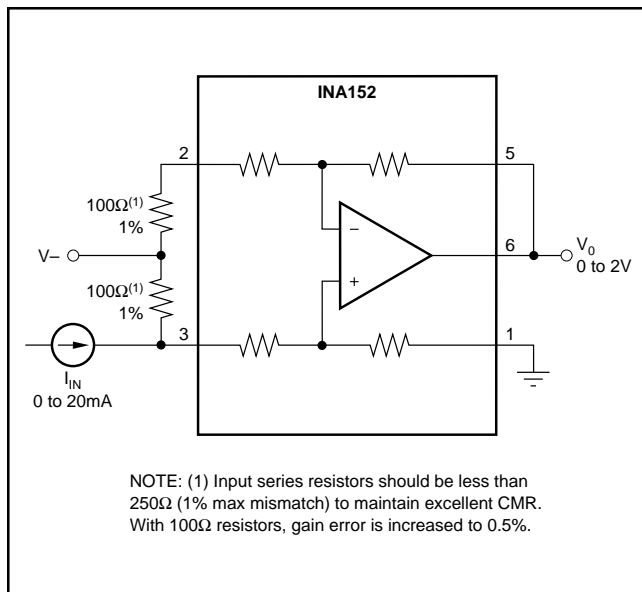

FIGURE 4. Current Receiver with Compliance to Rails.

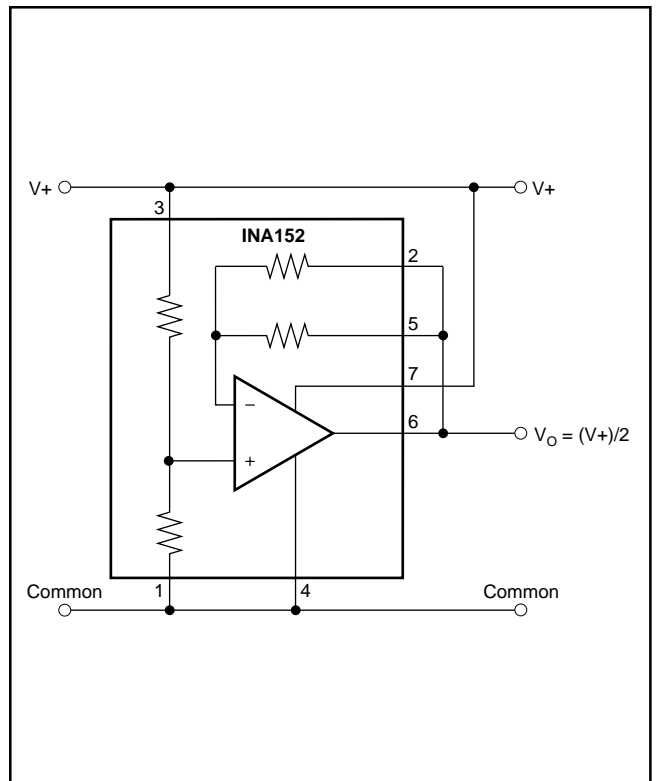

FIGURE 5. Pseudoground Generator.

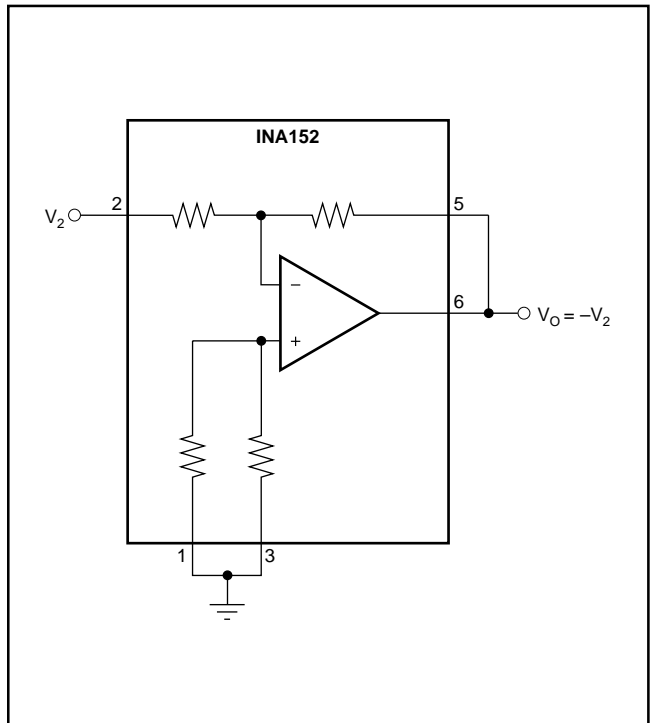

FIGURE 6. Precision Unity-Gain Inverting Amplifier.

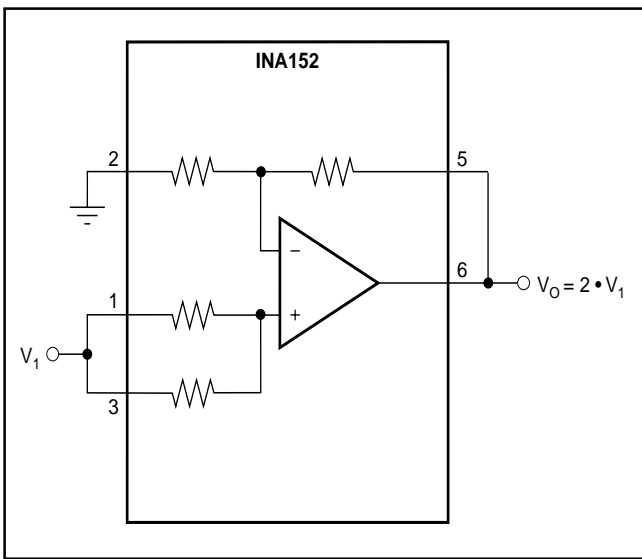

FIGURE 7. Precision Gain = 2 Amplifier.

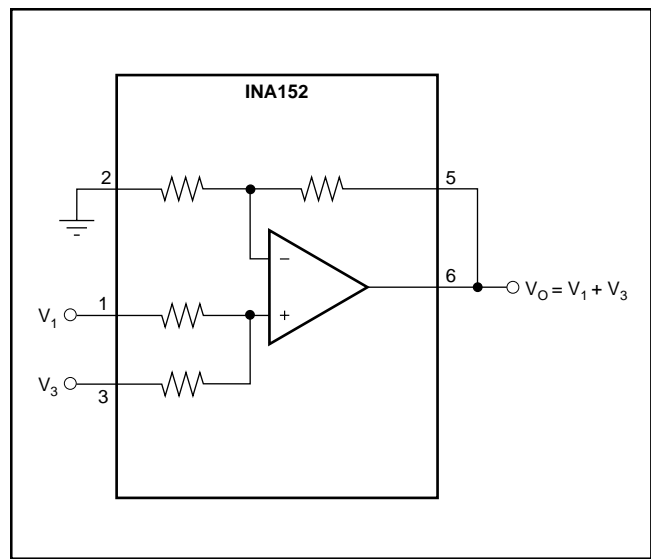

FIGURE 10. Precision Summing Amplifier.

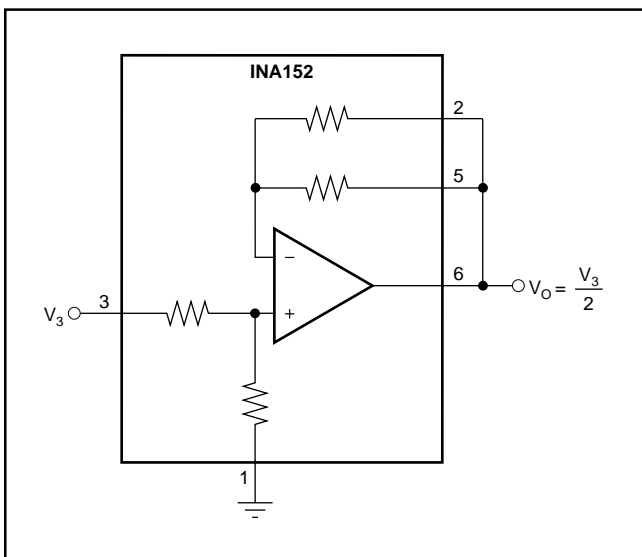

FIGURE 8. Precision Gain = 1/2 Amplifier.

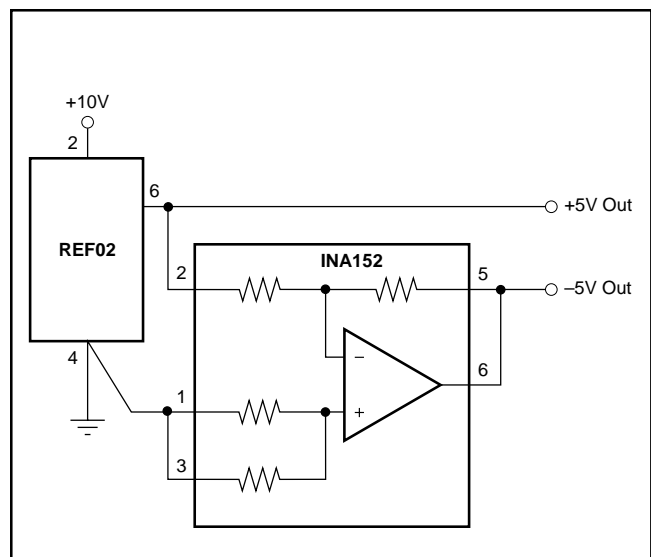

FIGURE 11. ±5V Precision Voltage Reference.

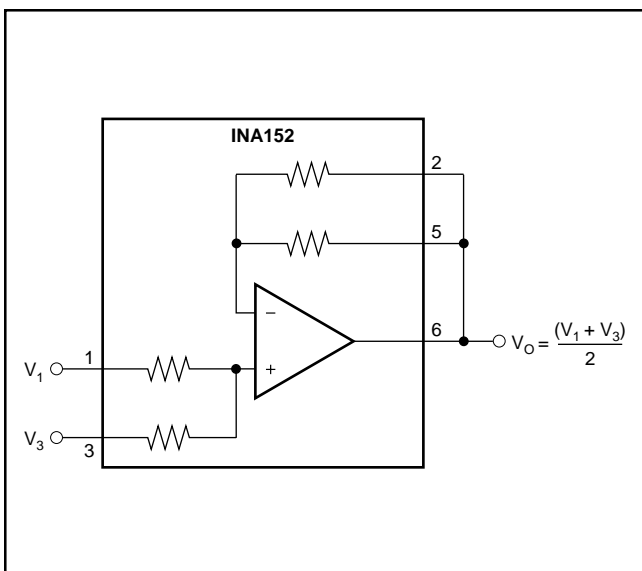

FIGURE 9. Precision Average Value Amplifier.

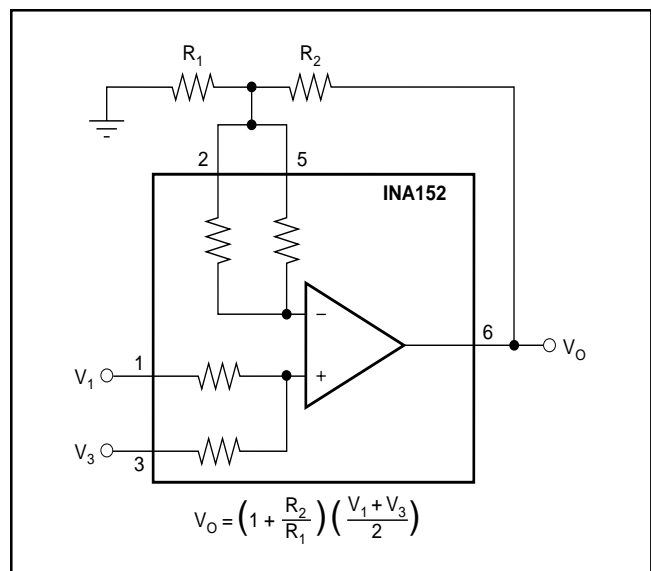

FIGURE 12. Precision Summing Amplifier with Gain.

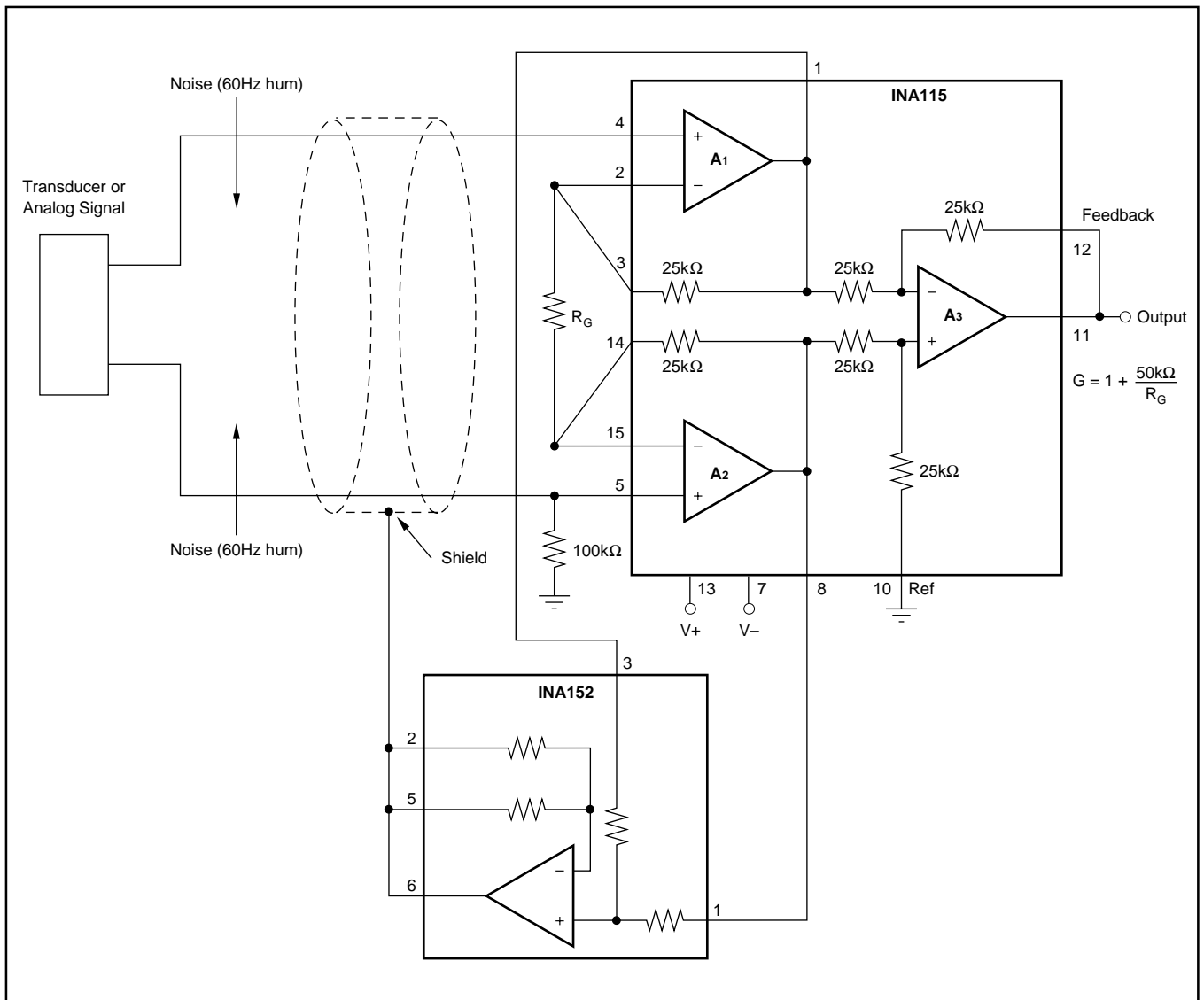

FIGURE 13. Instrumentation Amplifier Guard Drive Generator.

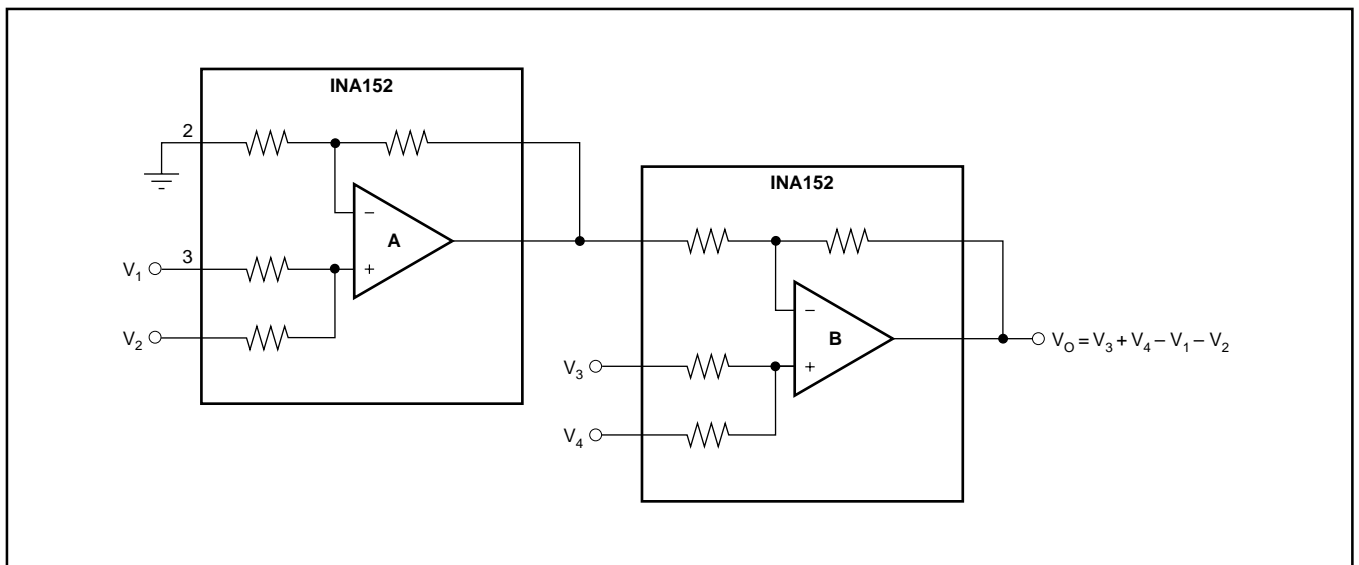

FIGURE 14. Precision Summing Instrumentation Amplifier.

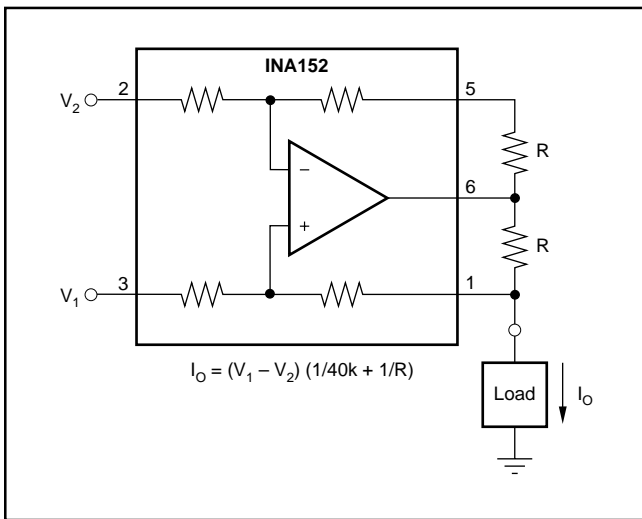

FIGURE 15. Precision Voltage-to-Current Converter with Differential Inputs.

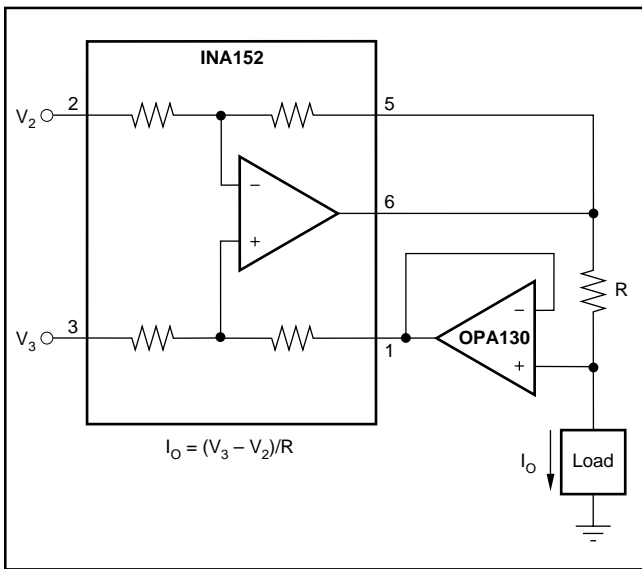

FIGURE 16. Differential Input Voltage-to-Current Converter for Low  $I_{OUT}$ .

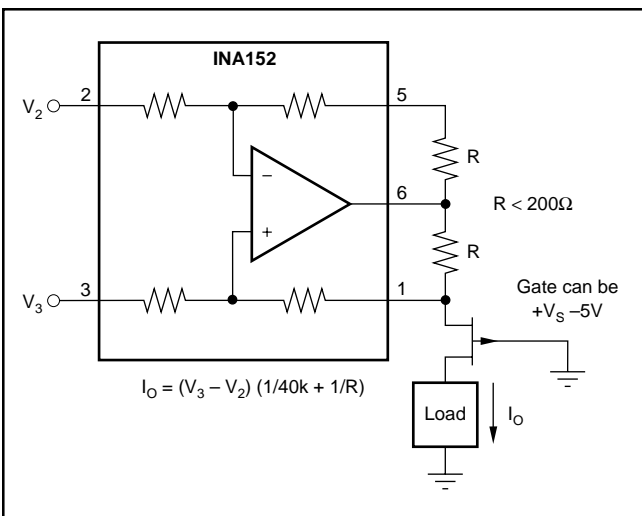

FIGURE 17. Isolating Current Source.

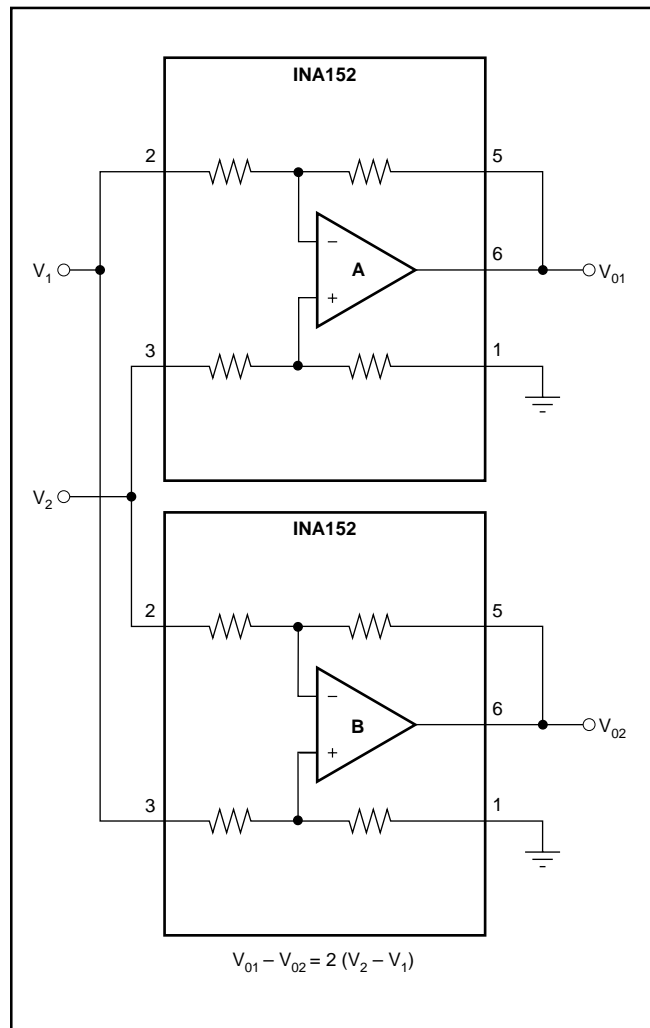

FIGURE 18. Differential Output Difference Amplifier.

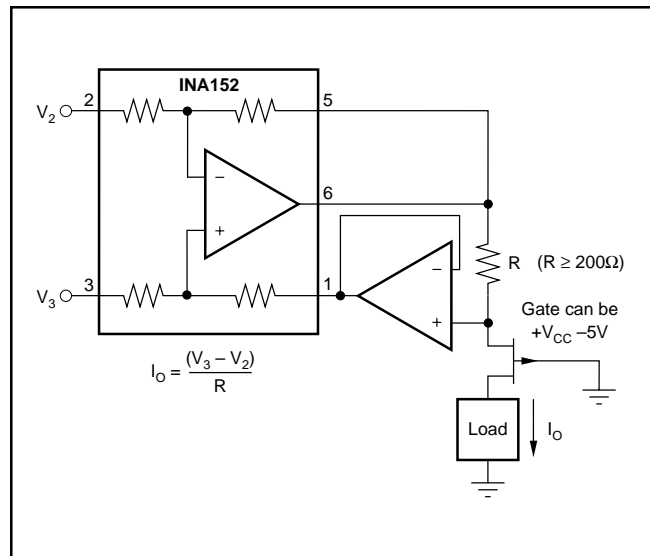

FIGURE 19. Isolating Current Source with Buffering Amplifier for Greater Accuracy.

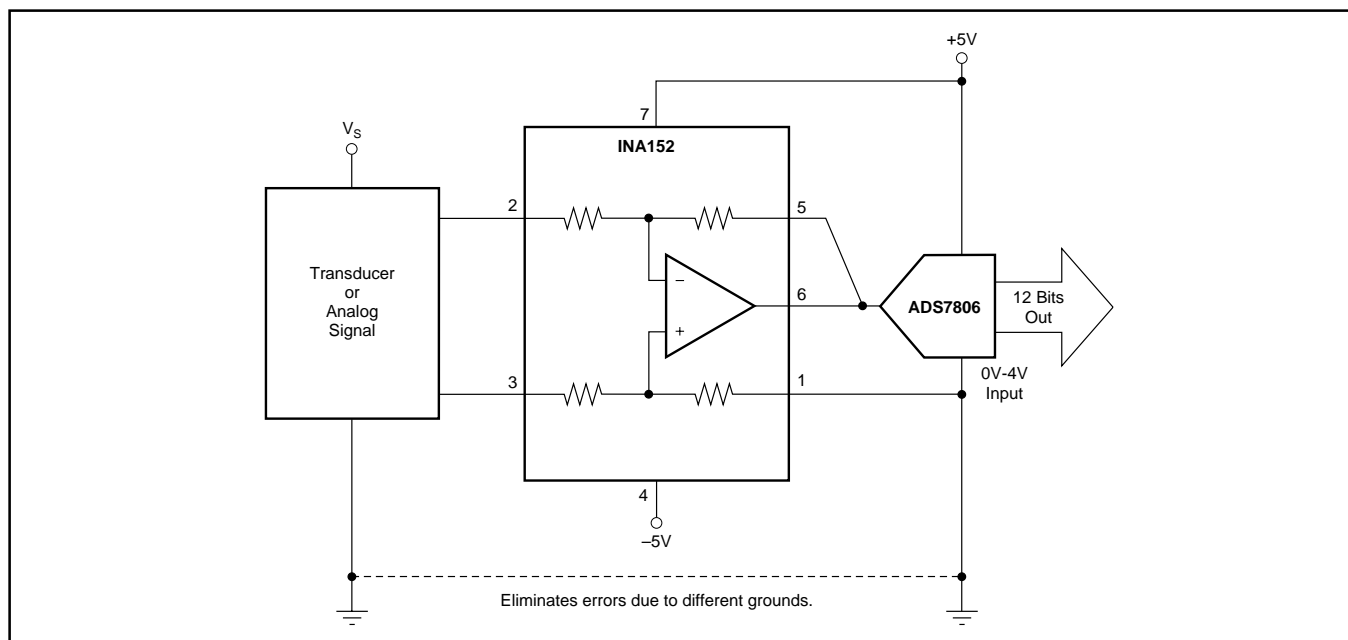

FIGURE 20. Differential Input Data Acquisition.

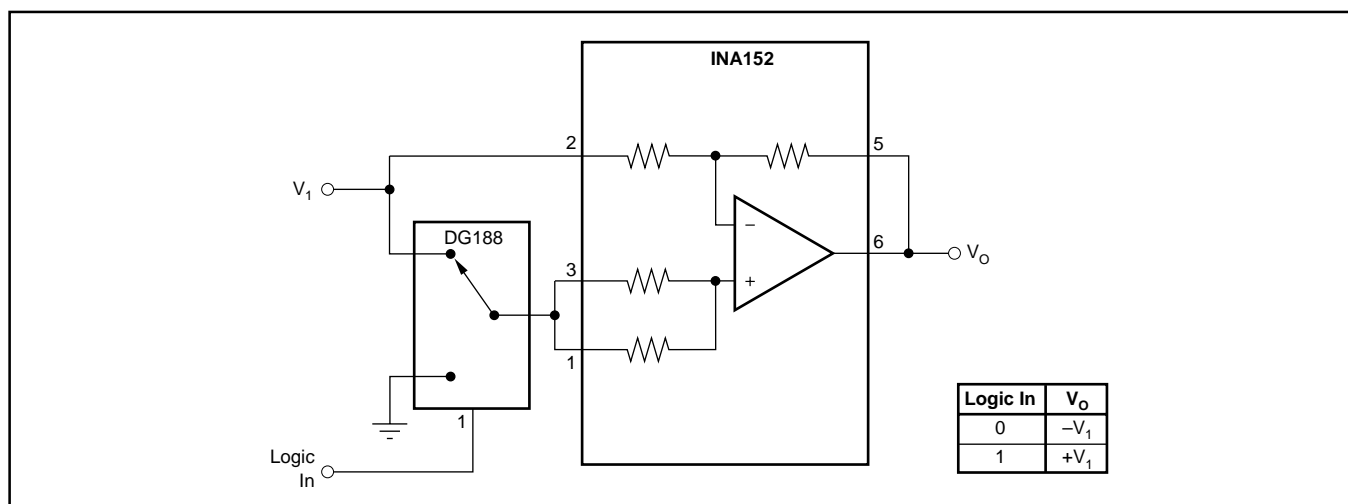

FIGURE 21. Digitally Controlled Gain of  $\pm 1$  Amplifier.

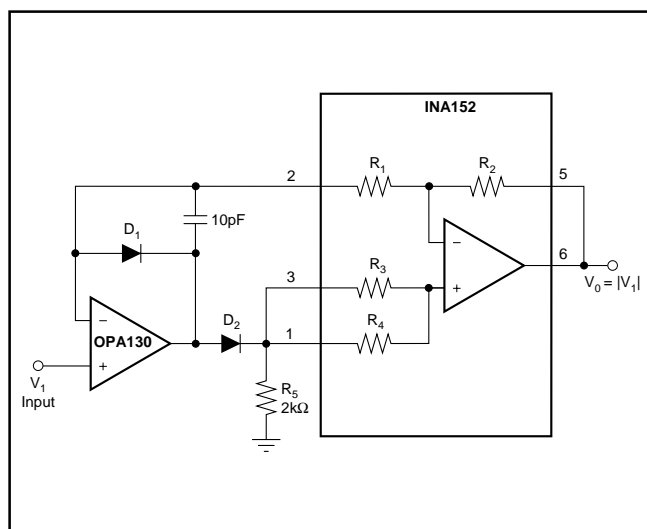

FIGURE 22. Precision Absolute Value Buffer.

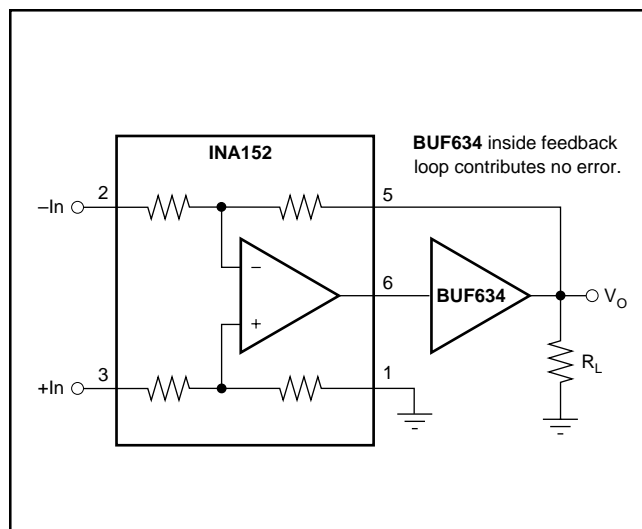

FIGURE 23. High Output Current Precision Difference Amplifier.

**PACKAGING INFORMATION**

Orderable Device	Status <sup>(1)</sup>	Package Type	Package Drawing	Pins	Package Qty	Eco Plan <sup>(2)</sup>	Lead/Ball Finish	MSL Peak Temp <sup>(3)</sup>
INA152EA/250	ACTIVE	MSOP	DGK	8	250	None	CU SNPB	Level-3-220C-168 HR
INA152EA/2K5	ACTIVE	MSOP	DGK	8	2500	None	CU SNPB	Level-3-220C-168 HR

<sup>(1)</sup> The marketing status values are defined as follows:

**ACTIVE:** Product device recommended for new designs.

**LIFEBUY:** TI has announced that the device will be discontinued, and a lifetime-buy period is in effect.

**NRND:** Not recommended for new designs. Device is in production to support existing customers, but TI does not recommend using this part in a new design.

**PREVIEW:** Device has been announced but is not in production. Samples may or may not be available.

**OBsolete:** TI has discontinued the production of the device.

<sup>(2)</sup> Eco Plan - May not be currently available - please check <http://www.ti.com/productcontent> for the latest availability information and additional product content details.

**None:** Not yet available Lead (Pb-Free).

**Pb-Free (RoHS):** TI's terms "Lead-Free" or "Pb-Free" mean semiconductor products that are compatible with the current RoHS requirements for all 6 substances, including the requirement that lead not exceed 0.1% by weight in homogeneous materials. Where designed to be soldered at high temperatures, TI Pb-Free products are suitable for use in specified lead-free processes.

**Green (RoHS & no Sb/Br):** TI defines "Green" to mean "Pb-Free" and in addition, uses package materials that do not contain halogens, including bromine (Br) or antimony (Sb) above 0.1% of total product weight.

<sup>(3)</sup> MSL, Peak Temp. -- The Moisture Sensitivity Level rating according to the JEDEC industry standard classifications, and peak solder temperature.

**Important Information and Disclaimer:** The information provided on this page represents TI's knowledge and belief as of the date that it is provided. TI bases its knowledge and belief on information provided by third parties, and makes no representation or warranty as to the accuracy of such information. Efforts are underway to better integrate information from third parties. TI has taken and continues to take reasonable steps to provide representative and accurate information but may not have conducted destructive testing or chemical analysis on incoming materials and chemicals. TI and TI suppliers consider certain information to be proprietary, and thus CAS numbers and other limited information may not be available for release.

In no event shall TI's liability arising out of such information exceed the total purchase price of the TI part(s) at issue in this document sold by TI to Customer on an annual basis.

## IMPORTANT NOTICE

Texas Instruments Incorporated and its subsidiaries (TI) reserve the right to make corrections, modifications, enhancements, improvements, and other changes to its products and services at any time and to discontinue any product or service without notice. Customers should obtain the latest relevant information before placing orders and should verify that such information is current and complete. All products are sold subject to TI's terms and conditions of sale supplied at the time of order acknowledgment.

TI warrants performance of its hardware products to the specifications applicable at the time of sale in accordance with TI's standard warranty. Testing and other quality control techniques are used to the extent TI deems necessary to support this warranty. Except where mandated by government requirements, testing of all parameters of each product is not necessarily performed.

TI assumes no liability for applications assistance or customer product design. Customers are responsible for their products and applications using TI components. To minimize the risks associated with customer products and applications, customers should provide adequate design and operating safeguards.

TI does not warrant or represent that any license, either express or implied, is granted under any TI patent right, copyright, mask work right, or other TI intellectual property right relating to any combination, machine, or process in which TI products or services are used. Information published by TI regarding third-party products or services does not constitute a license from TI to use such products or services or a warranty or endorsement thereof. Use of such information may require a license from a third party under the patents or other intellectual property of the third party, or a license from TI under the patents or other intellectual property of TI.

Reproduction of information in TI data books or data sheets is permissible only if reproduction is without alteration and is accompanied by all associated warranties, conditions, limitations, and notices. Reproduction of this information with alteration is an unfair and deceptive business practice. TI is not responsible or liable for such altered documentation.

Resale of TI products or services with statements different from or beyond the parameters stated by TI for that product or service voids all express and any implied warranties for the associated TI product or service and is an unfair and deceptive business practice. TI is not responsible or liable for any such statements.

Following are URLs where you can obtain information on other Texas Instruments products and application solutions:

<b>Products</b>		<b>Applications</b>	
Amplifiers	<a href="http://amplifier.ti.com">amplifier.ti.com</a>	Audio	<a href="http://www.ti.com/audio">www.ti.com/audio</a>
Data Converters	<a href="http://dataconverter.ti.com">dataconverter.ti.com</a>	Automotive	<a href="http://www.ti.com/automotive">www.ti.com/automotive</a>
DSP	<a href="http://dsp.ti.com">dsp.ti.com</a>	Broadband	<a href="http://www.ti.com/broadband">www.ti.com/broadband</a>
Interface	<a href="http://interface.ti.com">interface.ti.com</a>	Digital Control	<a href="http://www.ti.com/digitalcontrol">www.ti.com/digitalcontrol</a>
Logic	<a href="http://logic.ti.com">logic.ti.com</a>	Military	<a href="http://www.ti.com/military">www.ti.com/military</a>
Power Mgmt	<a href="http://power.ti.com">power.ti.com</a>	Optical Networking	<a href="http://www.ti.com/opticalnetwork">www.ti.com/opticalnetwork</a>
Microcontrollers	<a href="http://microcontroller.ti.com">microcontroller.ti.com</a>	Security	<a href="http://www.ti.com/security">www.ti.com/security</a>
		Telephony	<a href="http://www.ti.com/telephony">www.ti.com/telephony</a>
		Video & Imaging	<a href="http://www.ti.com/video">www.ti.com/video</a>
		Wireless	<a href="http://www.ti.com/wireless">www.ti.com/wireless</a>

Mailing Address: Texas Instruments  
Post Office Box 655303 Dallas, Texas 75265