



For most current data sheet and other product information, visit www.burr-brown.com

High-Voltage, Programmable Gain DIFFERENCE AMPLIFIER

FEATURES

- **HIGH COMMON-MODE VOLTAGE:**
+40V at $V_S = +5V$
 $\pm 100V$ at $V_S = \pm 15V$
- **DIFFERENTIAL GAIN = 0.1V/V TO 100V/V:**
Set with External Resistors
- **LOW QUIESCENT CURRENT: 570 μ A**
- **WIDE SUPPLY RANGE:**
Single Supply: 4.5V to 36V
Dual Supplies: $\pm 2.25V$ to $\pm 18V$
- **LOW GAIN ERROR: 0.025%**
- **HIGH CMR: 80dB**
- **SO-8 PACKAGE**

APPLICATIONS

- **CURRENT SHUNT MEASUREMENTS**
- **SENSOR AMPLIFIER**
- **SYNCHRONOUS DEMODULATOR**
- **CURRENT AND DIFFERENTIAL LINE RECEIVER**
- **VOLTAGE-CONTROLLED CURRENT SOURCE**
- **BATTERY POWERED SYSTEMS**
- **LOW COST AUTOMOTIVE INSTRUMENTATION**

DESCRIPTION

The INA146 is a precision difference amplifier that can be used to accurately attenuate high differential voltages and reject high common-mode voltages for compatibility with common signal processing voltage levels. High-voltage capability also affords inherent input protection. The input common-mode range extends beyond both supply rails, making the INA146 well-suited for both single and dual supply applications.

On-chip precision resistors are laser-trimmed to achieve accurate gain and high common-mode rejection. Excellent TCR tracking of these resistors assures continued high precision over temperature.

A 10:1 difference amplifier provides 0.1V/V gain when the output amplifier is used as a unity-gain buffer. In this configuration, input voltages up to $\pm 100V$ can be measured. Gains greater than 0.1V/V can be set with an external resistor pair without affecting the common-mode input range.

The INA146 is available in the SO-8 surface-mount package specified for the extended industrial temperature range, $-40^{\circ}C$ to $+85^{\circ}C$.

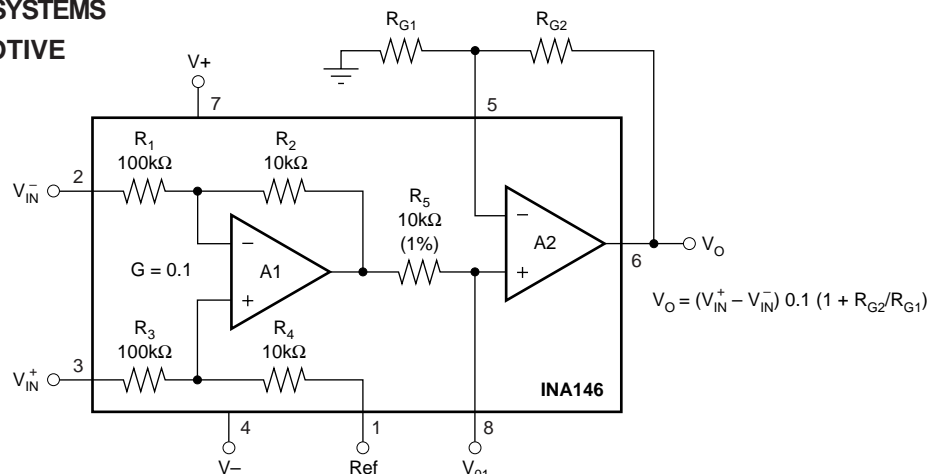

SPECIFICATIONS: $V_S = \pm 2.25V$ to $\pm 18V$ Dual Supplies

At $T_A = +25^\circ C$, $G = 0.1$, $R_L = 10k\Omega$ connected to ground and ref pin connected to ground unless otherwise noted.

Boldface limits apply over the specified temperature range, $T_A = -40^\circ C$ to $+85^\circ C$.

PARAMETER	CONDITION	INA146UA			UNITS
		MIN	TYP	MAX	
OFFSET VOLTAGE, V_O Input Offset Voltage vs Temperature vs Power Supply vs Time Offset Voltage, V_{O1}	RTI ^(1, 2) $V_S = \pm 15, V_{CM} = V_O = 0V$		± 1	± 5	mV
	V_{OS} $\Delta V_{OS}/\Delta T$ PSRR $V_S = \pm 1.35V$ to $\pm 18V$		See Typical Curve		± 600
INPUT VOLTAGE RANGE Common-Mode Voltage Range Common-Mode Rejection Over Temperature	$(V_{IN+}) - (V_{IN-}) = 0V, V_O = 0V$ $V_{CM} = 11 (V-) \text{ to } 11 (V+) = 11, R_S = 0\Omega$			$\pm 100^{(3)}$	V dB dB
	V_{CM} CMRR	70 64	80 74		
INPUT BIAS CURRENT⁽²⁾ Bias Current Offset Current	$V_{CM} = V_S/2$		± 50		nA nA
		I_B I_{OS}		± 5	
INPUT IMPEDANCE Differential (non-inverting input) Differential (inverting input) Common-Mode			110 91.7 55		k Ω k Ω k Ω
	NOISE Voltage Noise, $f = 0.1Hz$ to $10Hz$ Voltage Noise Density, $f = 1kHz$	RTI ^(1, 4)		10 550	$\mu Vp-p$ nV/ \sqrt{Hz}
	e_n				
GAIN Gain Equation Initial ⁽¹⁾ Gain Error vs Temperature vs Temperature Nonlinearity	$R_L = 100k\Omega, V_O = (V-)+0.15$ to $(V+)-1, G = 1$ $R_L = 100k\Omega, V_O = (V-)+0.25$ to $(V+)-1, G = 1$ $R_L = 10k\Omega, V_O = (V-)+0.3$ to $(V+)-1.25, G = 1$ $R_L = 10k\Omega, V_O = (V-)+0.5$ to $(V+)-1.25, G = 1$ $V_O = (V-)+0.3$ to $(V+)-1.25, G = 1$	$G = 0.1$ to 100 $G = 0.1 \cdot (1 + R_{G2}/R_{G1})$			V/V V/V % % % % of FS
		0.1	± 0.025	± 0.1	
		± 1	± 0.025	± 0.1	
		± 1	± 10	± 10	
		± 0.001	± 0.001	± 0.01	
FREQUENCY RESPONSE Small Signal Bandwidth Slew Rate Settling Time, 0.1% 0.01% Overload Recovery	$G = 0.1$ $G = 1$ $G = 1, 10V$ Step $G = 1, 10V$ Step 50% Input Overload		550 50 0.45 40 80 40		kHz kHz V/ μs μs μs μs
OUTPUT, V_O Voltage Output Over Temperature Over Temperature Short-Circuit Current Capacitive Load	$R_L = 100k\Omega, G = 1$ $R_L = 100k\Omega, G = 1$ $R_L = 10k\Omega, G = 1$ $R_L = 10k\Omega, G = 1$ Continuous to Common Stable Operation	$(V-) + 0.15$ $(V-) + 0.25$ $(V-) + 0.3$ $(V-) + 0.5$		$(V+) - 1$ $(V+) - 1$ $(V+) - 1.25$ $(V+) - 1.25$	V V V V mA pF
			± 15 1000		
POWER SUPPLY Specified Voltage Range, Dual Supplies Operating Voltage Range Quiescent Current Over Temperature	$V_{IN} = 0, I_O = 0$	± 2.25 ± 1.35		± 18 ± 18 ± 700 ± 750	V V μA μA
			± 570		
TEMPERATURE RANGE Specified Range Operating Range Storage Range Thermal Resistance	θ_{JA}	-40 -55 -55		+85 +125 +125	$^\circ C$ $^\circ C$ $^\circ C$ $^\circ C/W$
			150		

NOTES: (1) Overall difference amplifier configuration. Referred to input pins (V_{IN+} and V_{IN-}), gain = 0.1V/V. Specified with 10k Ω in feedback of A2. (2) Input offset voltage specification includes effects of amplifier's input bias and offset currents. (3) Common-mode voltage range is 11 (V-) to 11 [(V+) - 1] with a maximum of $\pm 100V$. (4) Includes effects of input current noise and thermal noise contribution of resistor network.

The information provided herein is believed to be reliable; however, BURR-BROWN assumes no responsibility for inaccuracies or omissions. BURR-BROWN assumes no responsibility for the use of this information, and all use of such information shall be entirely at the user's own risk. Prices and specifications are subject to change without notice. No patent rights or licenses to any of the circuits described herein are implied or granted to any third party. BURR-BROWN does not authorize or warrant any BURR-BROWN product for use in life support devices and/or systems.

SPECIFICATIONS: $V_S = +5V$ Single Supply

At $T_A = +25^\circ\text{C}$, $G = 1$, $R_L = 10\text{k}\Omega$ connected to $V_S/2$ and Ref pin connected to $V_S/2$ unless otherwise noted.

Boldface limits apply over the specified temperature range, $T_A = -40^\circ\text{C}$ to $+85^\circ\text{C}$.

PARAMETER	CONDITION	INA146UA			UNITS
		MIN	TYP	MAX	
OFFSET VOLTAGE, V_O Input Offset Voltage V_{OS} vs Temperature $\Delta V_{OS}/\Delta T$ vs Power Supply Rejection Ratio PSRR vs Time	RTI ^(1, 2) $V_{CM} = V_O = 0V$ $V_S = \pm 1.35V$ to $\pm 18V$		± 3 See Typical Curve ± 100 ± 3	± 10 ± 600	mV $\mu\text{V}/^\circ\text{C}$ $\mu\text{V}/\text{mo}$
INPUT VOLTAGE RANGE Common-Mode Voltage Range V_{CM} Common-Mode Rejection Ratio CMRR Over Temperature	$V_{IN+} - V_{IN-} = 0V$, $V_O = 0V$ $V_{CM} = -25V$ to $+19V$, $R_S = 0\Omega$	-25 70 64	80 74	19	V dB dB
INPUT BIAS CURRENT⁽²⁾ Bias Current I_B Offset Current I_{OS}			± 50 ± 5		nA nA
INPUT IMPEDANCE Differential (non-inverting input) Differential (inverting input) Common-Mode			110 91.7 55		k Ω k Ω k Ω
NOISE Voltage Noise, $f = 0.1\text{Hz}$ to 10Hz Voltage Noise Density, $f = 1\text{kHz}$ e_n	RTI ^(1, 3, 4)		10 550		$\mu\text{Vp-p}$ nV/ $\sqrt{\text{Hz}}$
GAIN Gain Equation Initial ⁽¹⁾ Gain Error vs Temperature vs Temperature Nonlinearity	$R_L = 100\text{k}\Omega$, $V_O = 0.15V$ to $4V$, $G = 1$ $R_L = 100\text{k}\Omega$, $V_O = 0.25V$ to $4V$, $G = 1$ $R_L = 10\text{k}\Omega$, $V_O = 0.3V$ to $3.75V$, $G = 1$ $R_L = 10\text{k}\Omega$, $V_O = 0.5V$ to $3.75V$, $G = 1$ $V_O = +0.3$ to $+3.75$, $G = 1$		$G = 0.1$ to 100 $G = 0.1 \cdot (1 + R_{G2}/R_{G1})$ 0.1 ± 0.025 ± 1 ± 0.025 ± 1 ± 0.001	± 0.1 ± 10 ± 0.1 ± 10 ± 0.01	V/V V/V V/V % ppm/ $^\circ\text{C}$ % ppm/ $^\circ\text{C}$ % of FS
FREQUENCY RESPONSE Small Signal Bandwidth Slew Rate Settling Time, 0.1% 0.01% Overload Recovery	$G = 0.1$ $G = 1$ $G = 1$, 10V Step $G = 1$, 10V Step 50% Input Overload		550 50 0.45 40 80 40		kHz kHz V/ μs μs μs μs
OUTPUT, V_O Voltage Output Over Temperature Over Temperature Short-Circuit Current Capacitive Load	$R_L = 100\text{k}\Omega$, $G = 1$ $R_L = 100\text{k}\Omega$, $G = 1$ $R_L = 10\text{k}\Omega$, $G = 1$ $R_L = 10\text{k}\Omega$, $G = 1$ Continuous to Common Stable Operation	0.15 0.25 0.3 0.5		4 4 3.75 3.75 ± 15 1000	V V V V mA pF
POWER SUPPLY Voltage Range, Dual Supplies Voltage Range, Single Supply Quiescent Current Over Temperature	$V_{IN} = 0$, $I_O = 0$	± 2.25 ± 4.5		± 18 ± 36 ± 700 ± 750	V V μA μA
TEMPERATURE RANGE Specified Range Operating Range Storage Range Thermal Resistance θ_{JA}		-40 -55 -55		+85 +125 +125	$^\circ\text{C}$ $^\circ\text{C}$ $^\circ\text{C}$ $^\circ\text{C}/\text{W}$

NOTES: (1) Overall difference amplifier configuration. Referred to input pins (V_{IN+} and V_{IN-}), gain = $0.1V/V$. Specified with $10\text{k}\Omega$ in feedback of A2. (2) Input offset voltage specification includes effects of amplifier's input bias and offset currents. (3) Includes effects of input current noise and thermal noise contribution of resistor network. (4) Common-mode voltage range is 11 (V-) to 11 [(V+) - 1] with a maximum of $\pm 100V$.

AMPLIFIER A1, A2 PERFORMANCE

At $T_A = +25^\circ\text{C}$, $G = 0.1$, $R_L = 10\text{k}\Omega$ connected to ground and Ref pin, unless otherwise noted.

Boldface limits apply over the specified temperature range, $T_A = -40^\circ\text{C}$ to $+85^\circ\text{C}$.

PARAMETER	CONDITION	INA146UA			UNITS
		MIN	TYP	MAX	
OFFSET VOLTAGE, V_O Input Offset Voltage vs Temperature	V_{OS} $\Delta V_{OS}/\Delta T$ RTI ^(1,2) $V_S = \pm 15\text{V}$, $V_{CM} = V_O = 0\text{V}$ $T_A = -40^\circ\text{C}$ to $+85^\circ\text{C}$		± 0.5 ± 1		mV $\mu\text{V}/^\circ\text{C}$
INPUT VOLTAGE RANGE Common-Mode Voltage Range Common-Mode Rejection Ratio	$V_{IN+} - V_{IN-} = 0\text{V}$, $V_O = 0\text{V}$ $V_{CM} = (V-) \text{ to } (V+) - 1$		$(V-) \text{ to } (V+) - 1$ 90		V dB
OPEN-LOOP GAIN Open Loop Gain	A_{OL}		110		dB
INPUT BIAS CURRENT⁽²⁾ Bias Current Offset Current	I_B I_{OS}		± 50 ± 5		nA nA
RESISTOR AT A1 OUTPUT, V_{O1} Initial Error Temperature Drift Coefficient			10 ± 1 ± 100		k Ω % ppm/ $^\circ\text{C}$

PIN CONFIGURATION

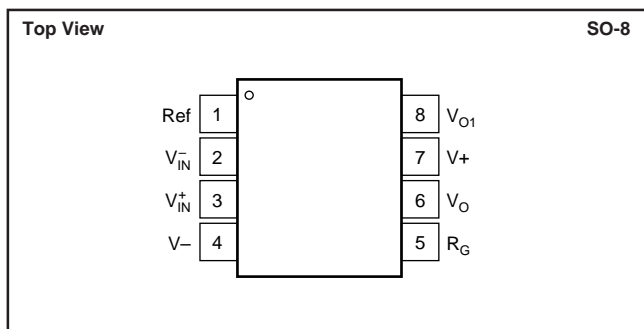

ELECTROSTATIC DISCHARGE SENSITIVITY

This integrated circuit can be damaged by ESD. Burr-Brown recommends that all integrated circuits be handled with appropriate precautions. Failure to observe proper handling and installation procedures can cause damage.

ESD damage can range from subtle performance degradation to complete device failure. Precision integrated circuits may be more susceptible to damage because very small parametric changes could cause the device not to meet its published specifications.

ABSOLUTE MAXIMUM RATINGS⁽¹⁾

Supply Voltage, $V+$ to $V-$	36V
Signal Input Terminals, Voltage	$\pm 100\text{V}$
Current	$\pm 1\text{mA}$
Output Short Circuit (to ground)	Continuous
Operating Temperature	-55°C to $+125^\circ\text{C}$
Storage Temperature	-55°C to $+150^\circ\text{C}$
Junction Temperature	$+150^\circ\text{C}$
Lead Temperature (soldering, 10s)	$+240^\circ\text{C}$

NOTE: (1) Stresses above these ratings may cause permanent damage. Exposure to absolute maximum conditions for extended periods may degrade device reliability.

PACKAGE/ORDERING INFORMATION

PRODUCT	PACKAGE	PACKAGE DRAWING NUMBER(1)	SPECIFIED TEMPERATURE RANGE	PACKAGE MARKING	ORDERING NUMBER(2)	TRANSPORT MEDIA
INA146UA	SO-8	182	-40°C to $+85^\circ\text{C}$	INA146UA	INA146UA INA146UA/2K5	Rails Tape and Reel

NOTES: (1) For detailed drawing and dimension table, please see end of data sheet, or Appendix C of Burr-Brown IC Data Book, or visit the Burr-Brown web site at www.burr-brown.com. (2) Models with a slash (/) are available only in Tape and Reel in the quantities indicated (e.g., /2K5 indicates 2500 devices per reel). Ordering 2500 pieces of "INA146UA/2K5" will get a single 2500-piece Tape and Reel. For detailed Tape and Reel mechanical information, refer to Appendix B of Burr-Brown IC Data Book.

TYPICAL PERFORMANCE CURVES

At $T_A = +25^\circ\text{C}$, $V_S = \pm 15\text{V}$, $G = 0.1$, $R_L = 10\text{k}\Omega$ connected to ground and Ref pin connected to ground, unless otherwise noted.

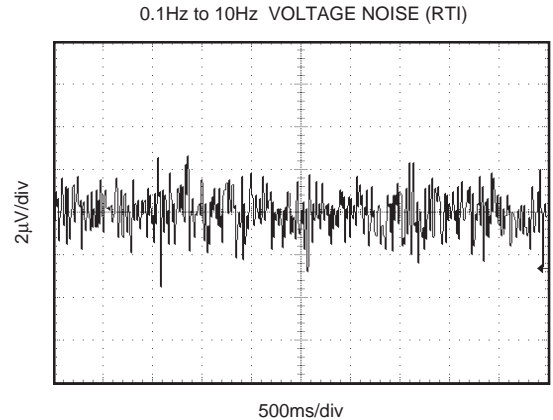
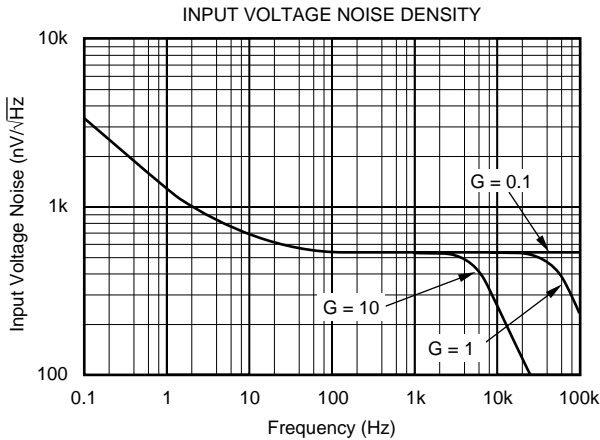
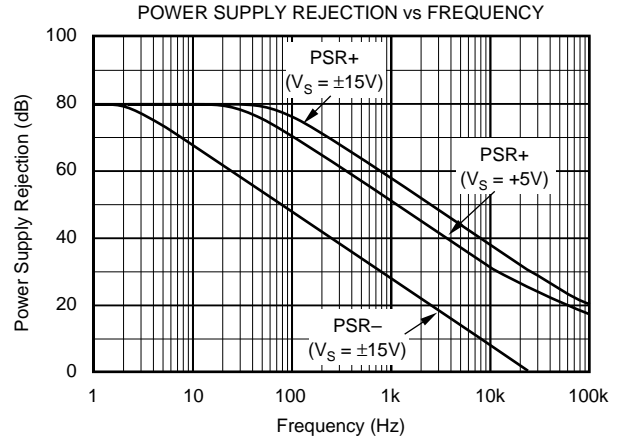
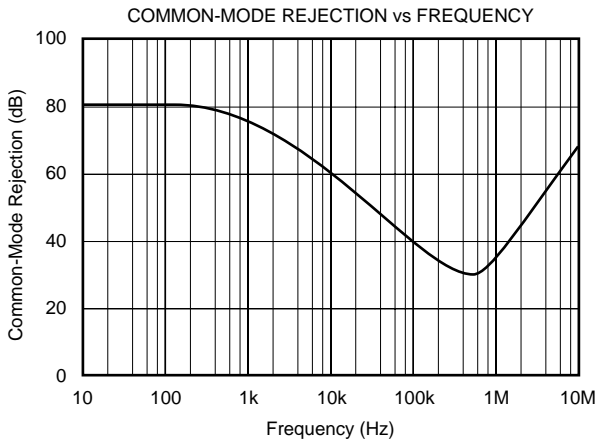
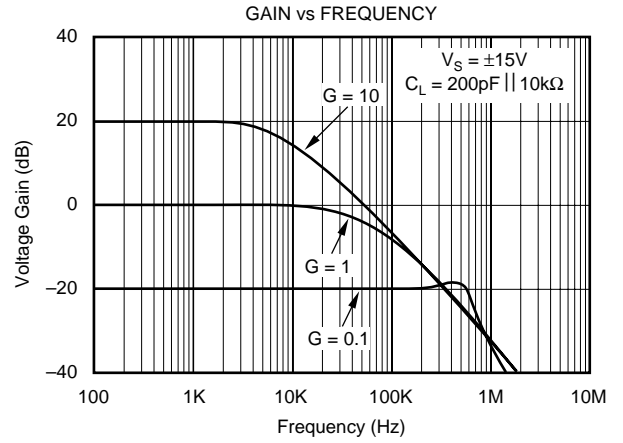
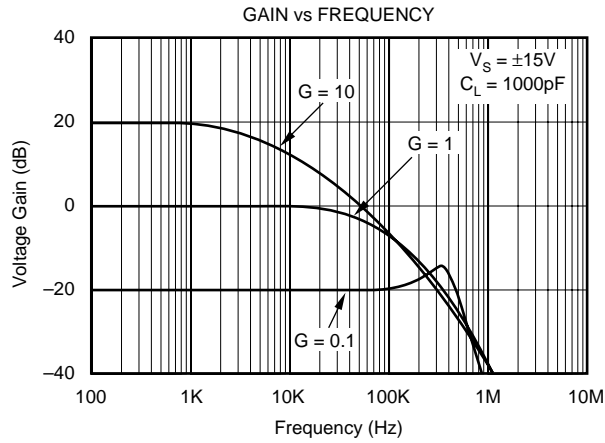

TYPICAL PERFORMANCE CURVES (Cont.)

At $T_A = +25^\circ\text{C}$, $V_S = \pm 15\text{V}$, $G = 0.1$, $R_L = 10\text{k}\Omega$ connected to ground and Ref pin connected to ground, unless otherwise noted.

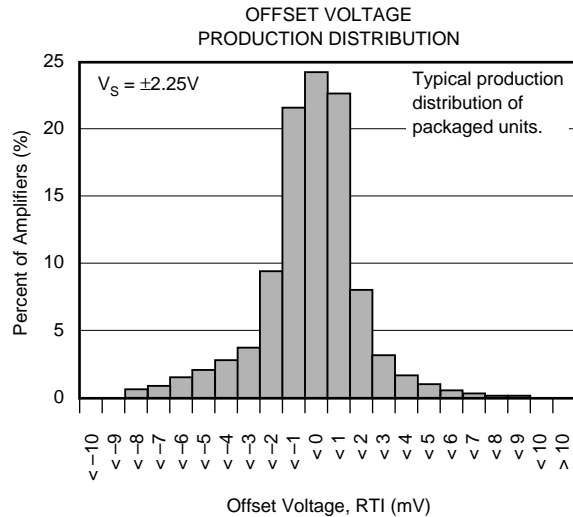
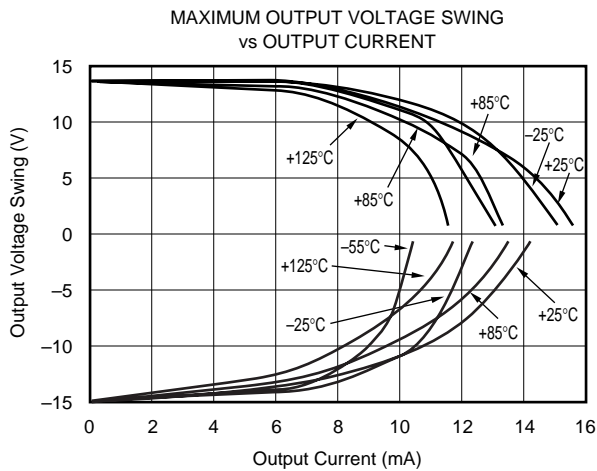
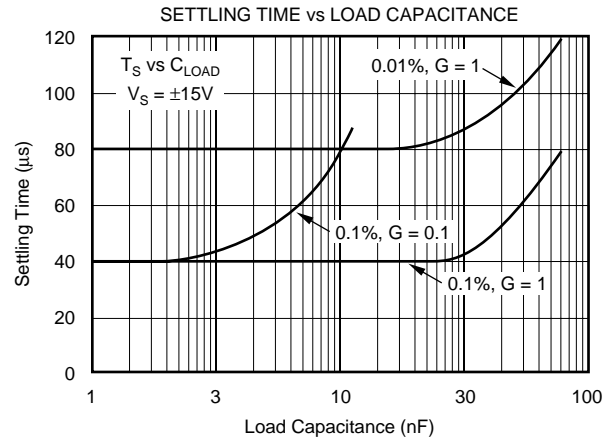
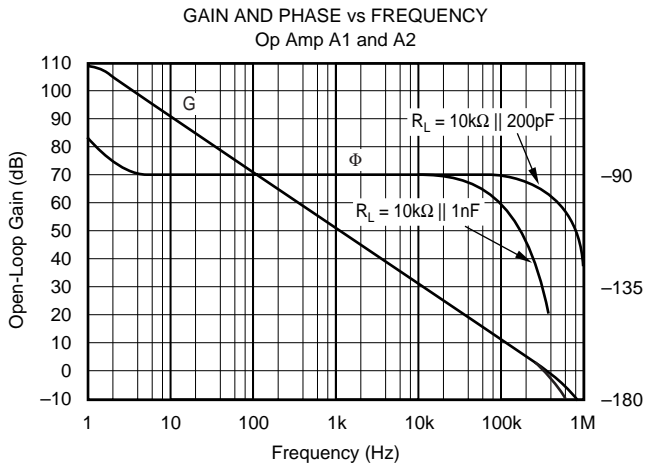
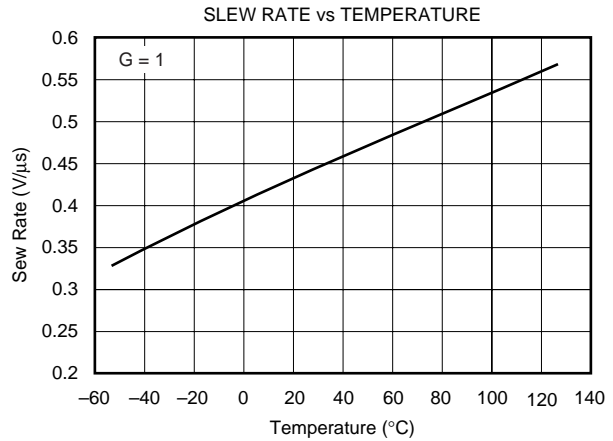
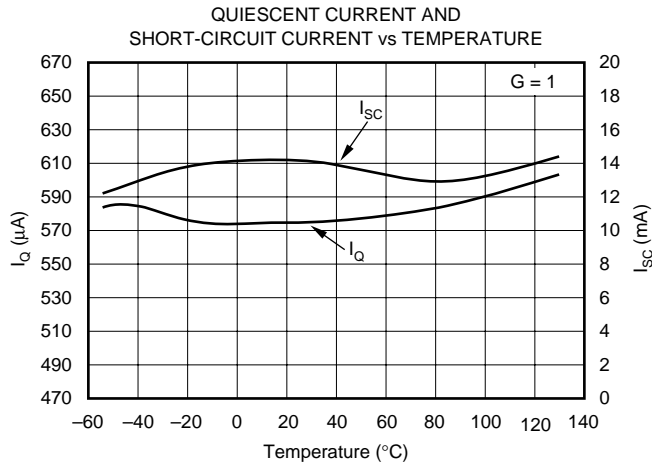

TYPICAL PERFORMANCE CURVES (Cont.)

At $T_A = +25^\circ\text{C}$, $V_S = \pm 15\text{V}$, $G = 0.1$, $R_L = 10\text{k}\Omega$ connected to ground and Ref pin connected to ground, unless otherwise noted.

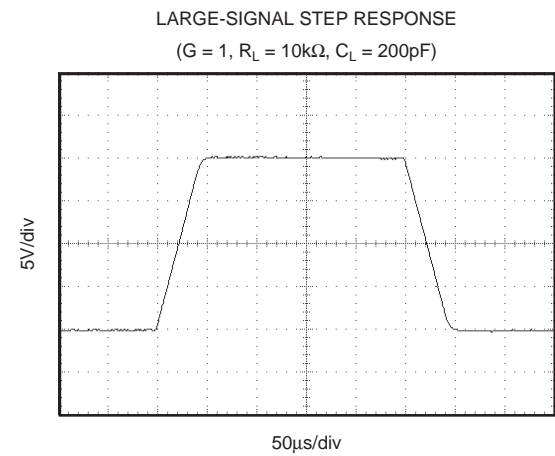
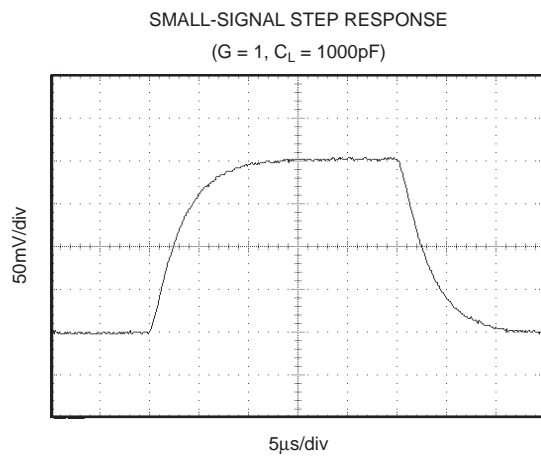
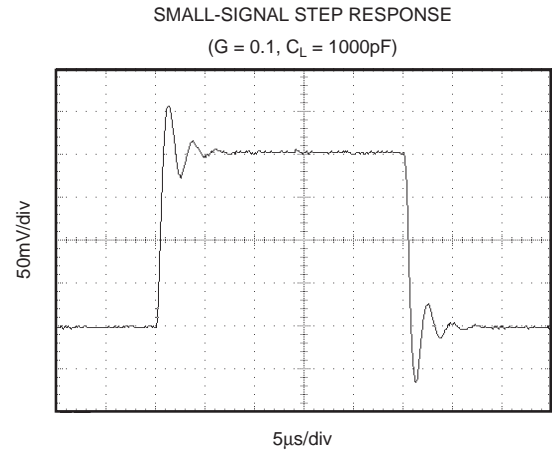
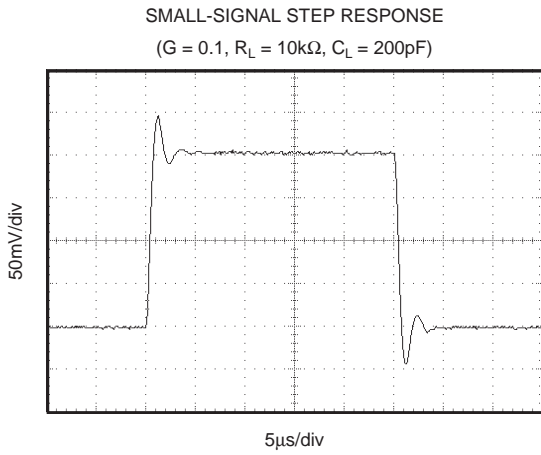
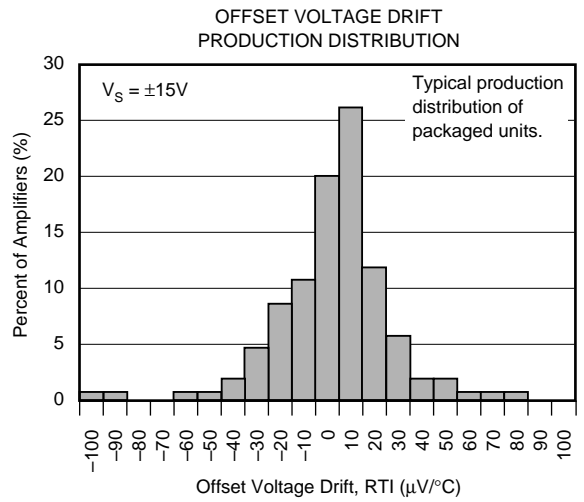
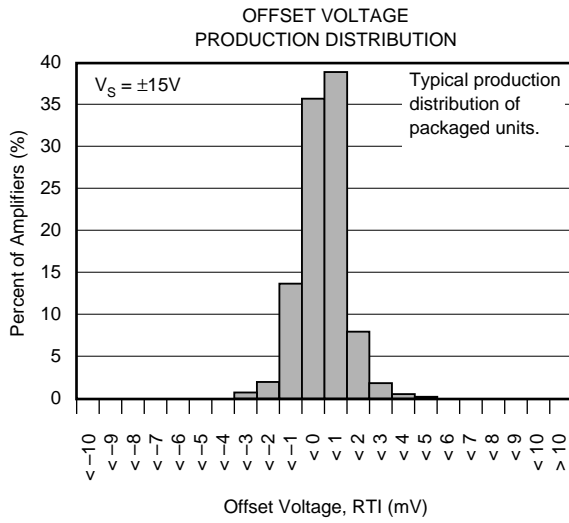

APPLICATION INFORMATION

The INA146 is a programmable gain difference amplifier consisting of a gain of 0.1 difference amplifier and a programmable-gain output buffer stage. Basic circuit connections are shown in Figure 1. Power supply bypass capacitors should be connected close to pins 4 and 7 as shown. The amplifier is programmable in the range of $G = 0.1$ to $G = 50$ with two external resistors.

The output of A1 is connected to the noninverting input of A2 through a $10k\Omega$ resistor which is trimmed to $\pm 1\%$ absolute accuracy. The A2 input is available for applications such as a filter or a precision current source. See application figures for examples.

OPERATING VOLTAGE

The INA146 is fully specified for supply voltages from $\pm 2.25V$ to $\pm 18V$ with key parameters guaranteed over the temperature range $-40^\circ C$ to $+85^\circ C$. The INA146 can be operated with single or dual supplies with excellent performance. Parameters that vary significantly with operating voltage, load conditions or temperature are shown in the typical performance curves.

SETTING THE GAIN

The gain of the INA146 is set by using two external resistors, R_{G1} and R_{G2} , according to the equation:

$$G = 0.1 \cdot (1 + R_{G2}/R_{G1})$$

For a total gain of 0.1, A2 is connected as a buffer amplifier with no R_{G1} . A feedback resistor, $R_{G2} = 10k\Omega$, should be used in the buffer connection. This provides bias current cancellation (in combination with internal R_5) to assure specified offset voltage performance. Commonly used values are shown in the table of Figure 1. Resistor values for other gains should be chosen to provide a $10k\Omega$ parallel resistance.

COMMON-MODE RANGE

The 10:1 input resistor ratio of the INA146 provides an input common-mode range that can extend well beyond the power supply rails. Exact range depends on the power supply voltage and the voltage applied to the Ref terminal (pin 1). To assure proper operation, the voltage at the non-inverting input of A1 (an internal node) must be within its linear operating range. Its voltage is determined by the simple 10:1 voltage divider between pin 3 and pin 1. This voltage must be between V_- and $(V_+) - 1V$.

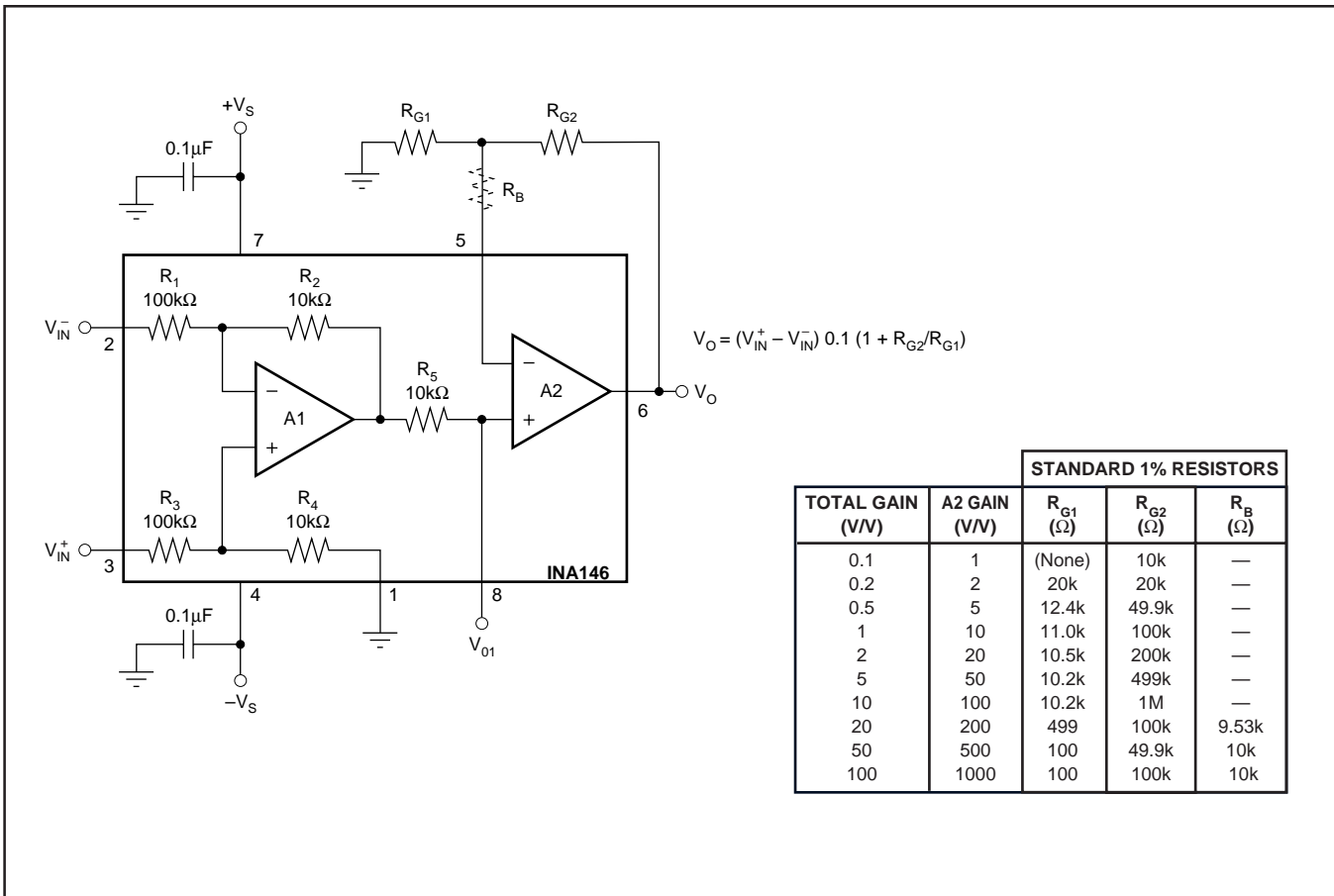

FIGURE 1. Basic Circuit Connections.

OFFSET TRIM

The INA146 is laser-trimmed for low offset voltage and drift. Most applications require no external offset adjustment. Figure 2 shows an optional circuit for trimming the offset voltage. A voltage applied to the Ref terminal will be summed with the output signal. This can be used to null offset voltage. To maintain good common-mode rejection, the source impedance of a signal applied to the Ref terminal should be less than 10Ω and a resistor added to the positive input terminal should be 10 times that, or 100Ω . Alternatively, the trim voltage can be buffered with an op amp such as the OPA277.

INPUT IMPEDANCE

The input impedance of the INA146 is determined by the input resistor network and is approximately $100k\Omega$. The source impedance at the two input terminals must be nearly equal to maintain good common-mode rejection. A 12Ω mismatch in impedance between the two inputs will cause the typical common-mode rejection to be degraded to approximately $72dB$. Figure 7 shows a common application measuring power supply current through a shunt resistor. The source impedance of the shunt resistor, R_S , is balanced by an equal compensation resistor, R_C .

Source impedances greater than 800Ω are not recommended, even if they are perfectly matched. Internal resistors are laser trimmed for accurate ratios, not to absolute values. Adding equal resistors greater than 800Ω can cause a mismatch in the total resistor ratios, degrading CMR.

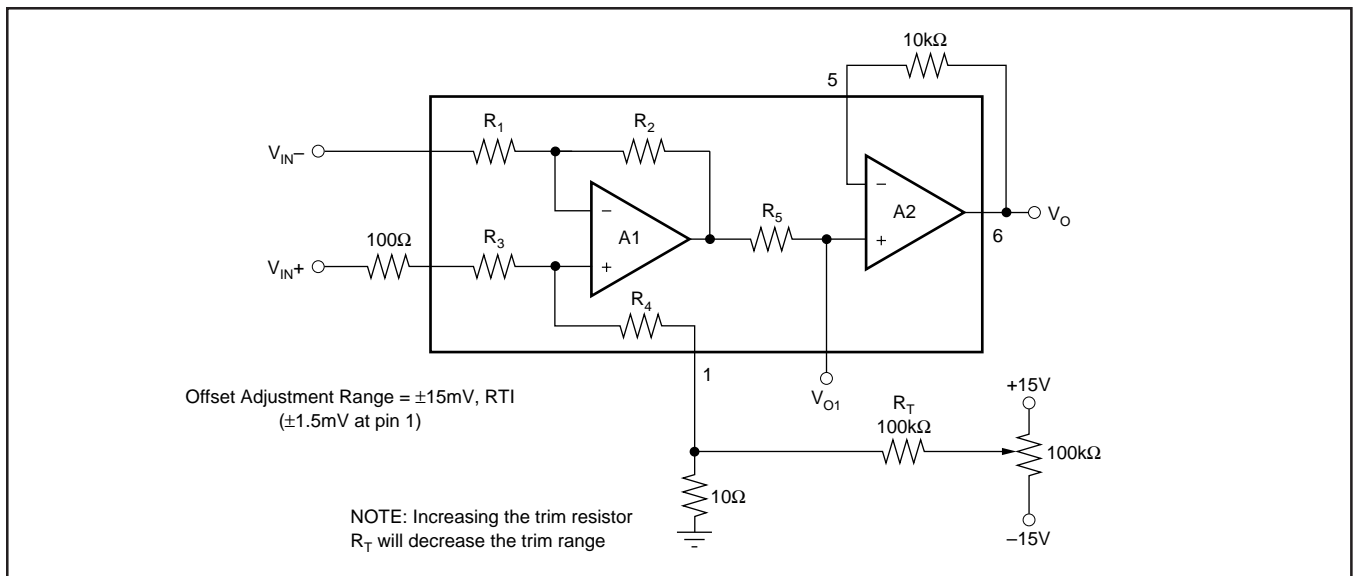

FIGURE 2. Optional Offset Trim Circuit.

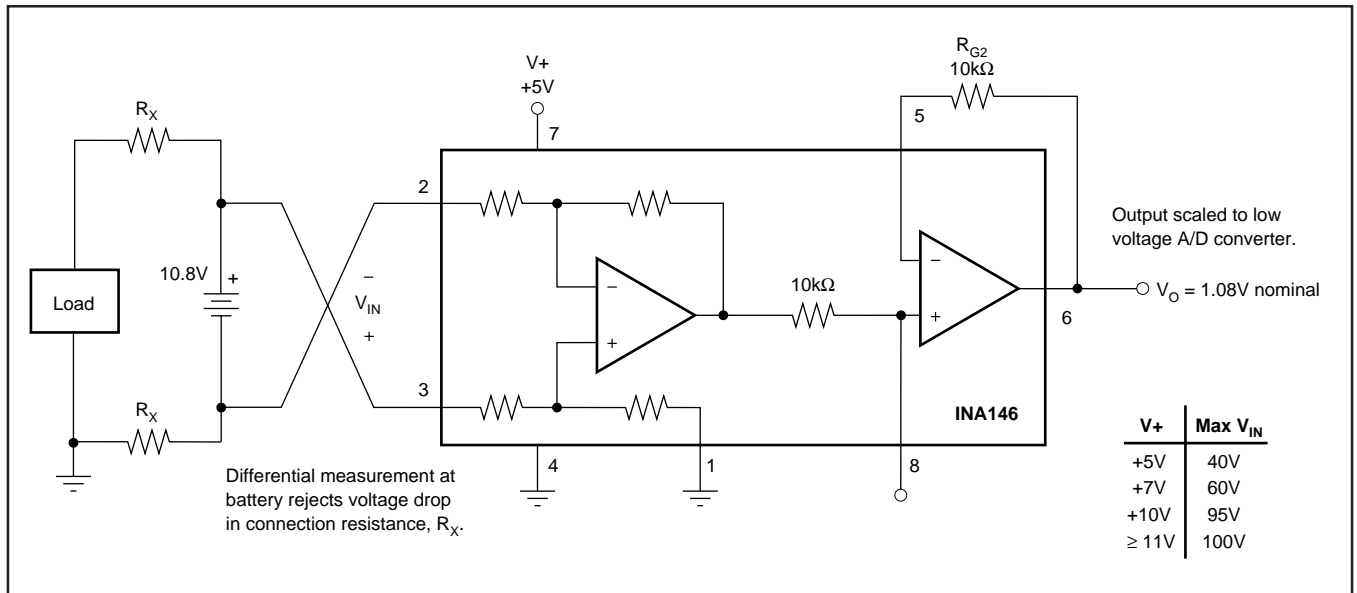

FIGURE 3. Measuring Voltages Greater than Supply Voltage.

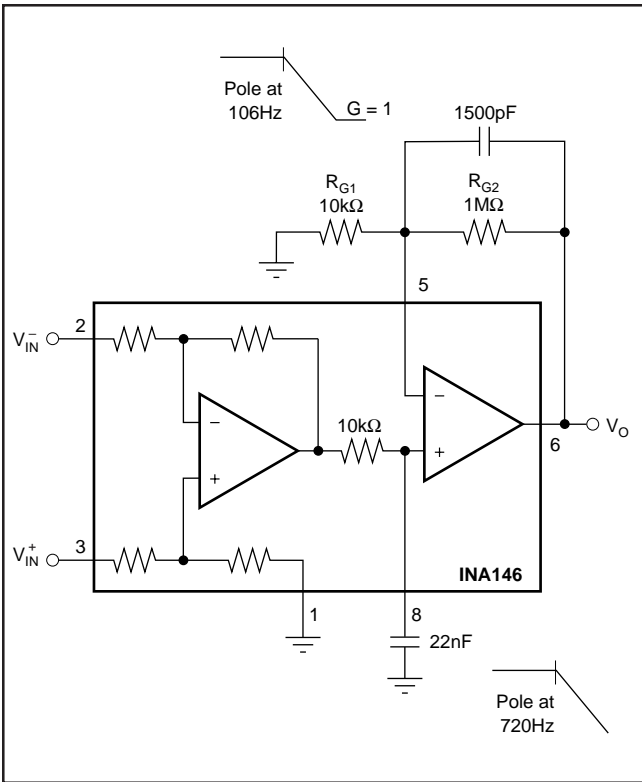

FIGURE 4. Noise Filtering.

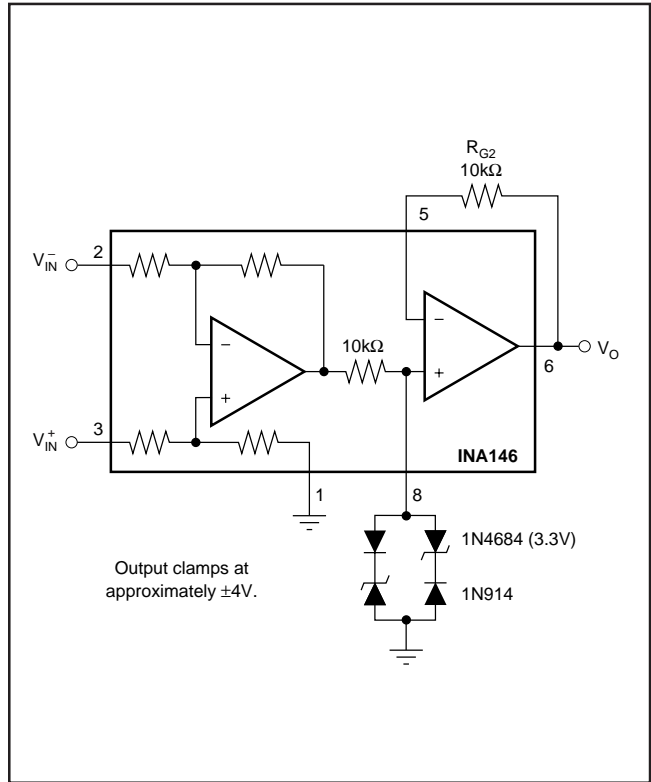
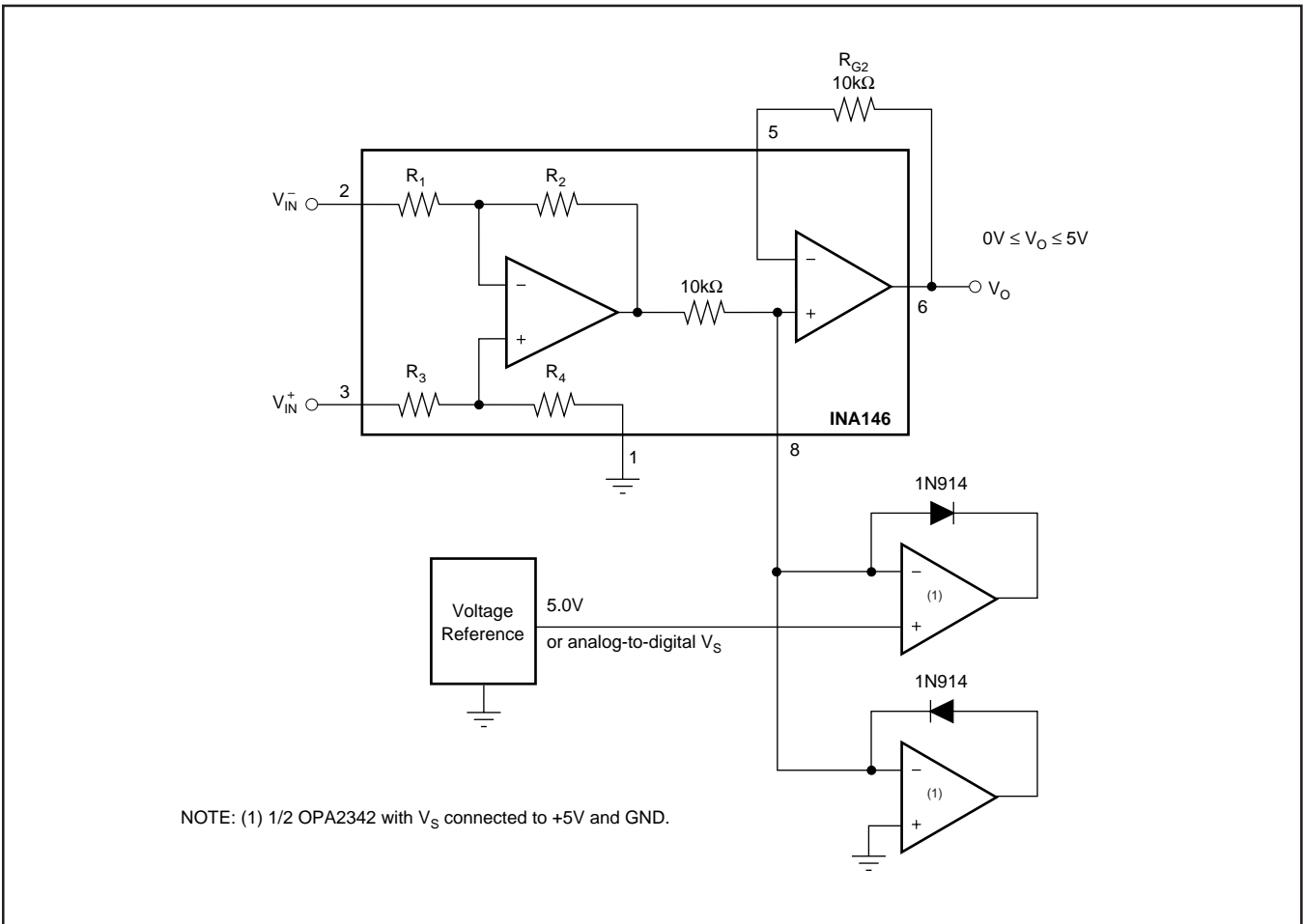

FIGURE 5. Output Clamp.



NOTE: (1) 1/2 OPA2342 with V_S connected to +5V and GND.

FIGURE 6. Precision Clamp.

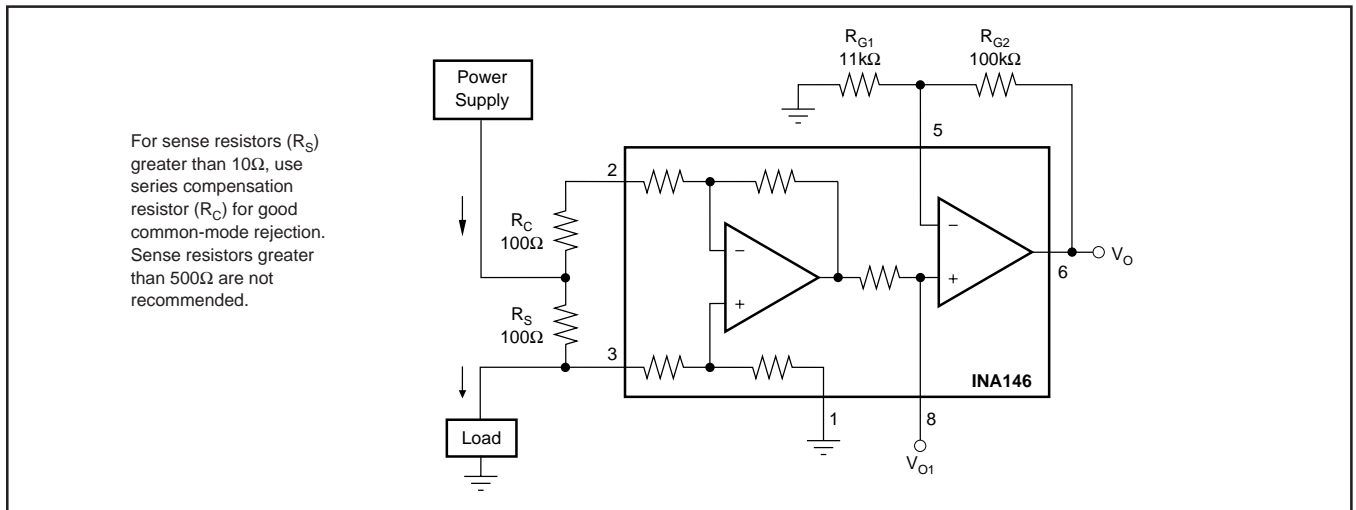

FIGURE 7. Current Monitor, $G = 1$.

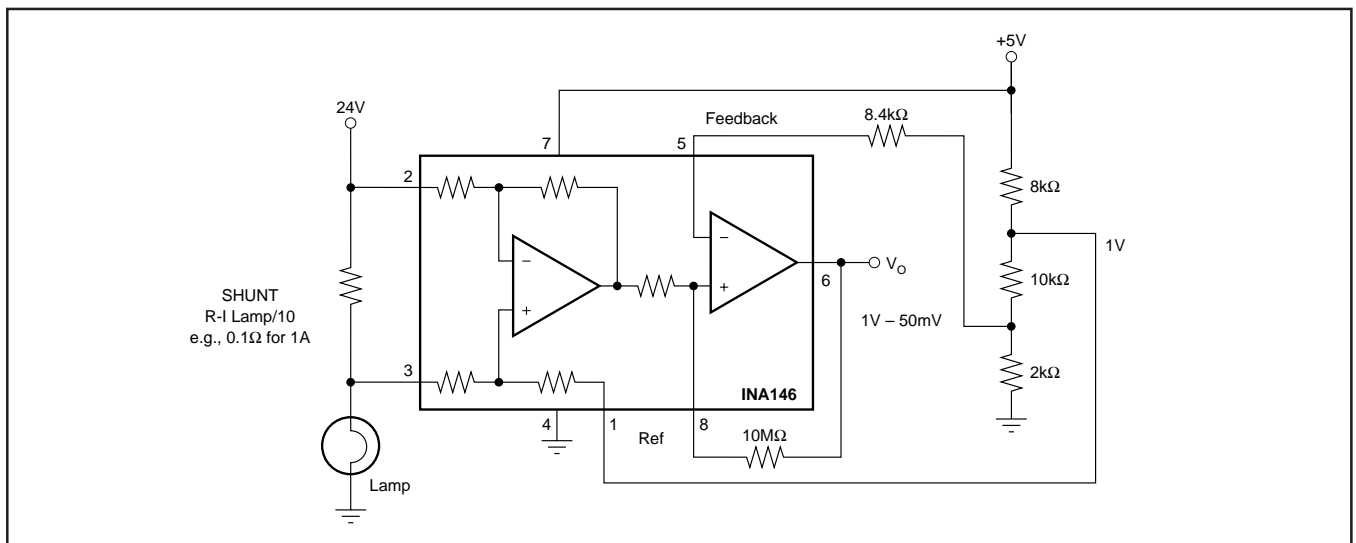

FIGURE 8. Comparator Output with Optional Hysteresis Application to Sense Lamp Burn-Out.

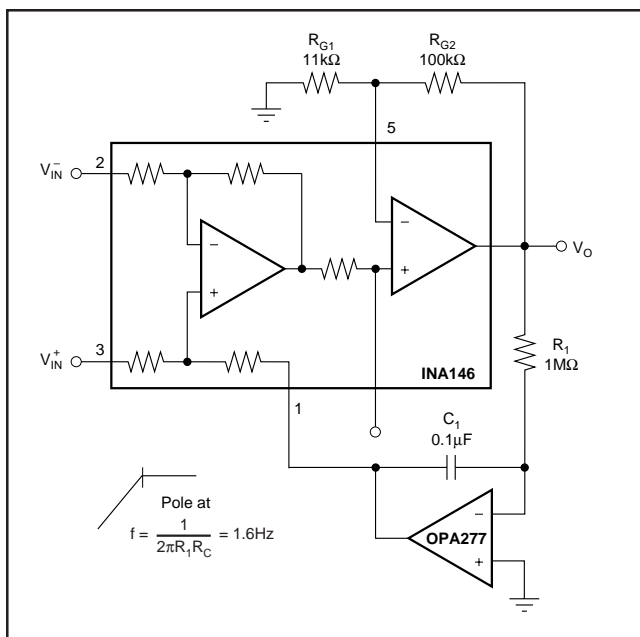

FIGURE 9. AC Coupling (DC Restoration).

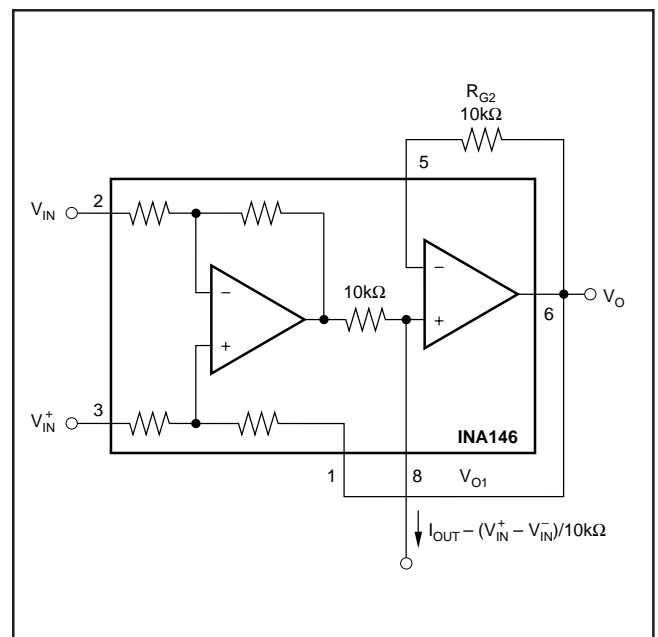

FIGURE 10. Precision Current Source.