

Optocoupler, PhotoSCR Output, 400 V_{RM}, 1 A surge current

Features

- Turn on current (I_{FT}), 5.0 mA typical
 - Gate trigger current (I_{GT}), 20 μA
 - Surge anode current, 1.0 AMP
 - Blocking voltage, 400 V
 - Gate trigger voltage (V_{GT}), 0.6 Volt
 - Isolation Test Voltage, 5300 V_{RMS}
 - Solid State Reliability
 - Standard DIP Package
 - Lead-free component
-
- Component in accordance to RoHS 2002/95/EC and WEEE 2002/96/EC

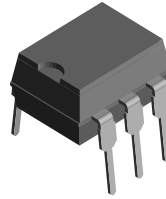

1179006

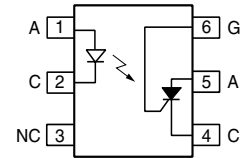

Agency Approvals

- UL1577, File No. E52744 System Code H or J, Double Protection
- DIN EN 60747-5-2 (VDE0884)
DIN EN 60747-5-5 pending
Available with Option 1

Order Information

Part	Remarks
IL400	Blocking voltage, 400 V, DIP-6
IL400-X007	Blocking voltage, 400 V, SMD-6 (option 7)
IL400-X009	Blocking voltage, 400 V, SMD-6 (option 9)

For additional information on the available options refer to Option Information.

Description

The IL400 is an optically coupled SCR with a gallium arsenide infrared emitter and a silicon photo SCR sensor. Switching can be achieved while maintaining a high degree of isolation between triggering and load circuits. The IL400 can be used in SCR triac and solid state relay applications where high blocking voltages and low input current sensitivity are required.

Absolute Maximum Ratings

T_{amb} = 25 °C, unless otherwise specified

Stresses in excess of the absolute Maximum Ratings can cause permanent damage to the device. Functional operation of the device is not implied at these or any other conditions in excess of those given in the operational sections of this document. Exposure to absolute Maximum Rating for extended periods of the time can adversely affect reliability.

Input

Parameter	Test condition	Symbol	Value	Unit
Peak reverse voltage		V _{RM}	6.0	V
Peak forward current (100 μs, 1 % duty cycle)		I _{FM}	1.0	A
Forward continuous current		I _F	60	mA
Power dissipation		P _{diss}	100	mW
Derate linearly from 25 °C			1.3	mW/°C

Output

Parameter	Test condition	Symbol	Value	Unit
Reverse gate voltage		V_{RG}	6.0	V
Anode voltage (DC or AC Peak)		V_A	400	V
Anode current		I_A	100	mA
Surge anode current (10 ms duration)		I_{AS}	1.0	A
Surge gate current (5.0 ms duration)		I_{GS}	200	mA
Power dissipation		P_{diss}	200	mW
Derate linearly from 25 °C			2.11	mW/°C

Coupler

Parameter	Test condition	Symbol	Value	Unit
Isolation voltage		V_{ISO}	5300	V_{RMS}
Isolation resistance	$V_{IO} = 500\text{ V}, T_{amb} = 25\text{ °C}$	R_{IO}	$> 10^{12}$	Ω
	$V_{IO} = 500\text{ V}, T_{amb} = 100\text{ °C}$	R_{IO}	$> 10^{12}$	Ω
Total package dissipation			250	mW
Derate linearly from 25 °			2.63	mW/°C
Operating temperature		T_{amb}	- 55 to +100	°C
Storage temperature		T_{stg}	- 55 to +150	°C

Electrical Characteristics

$T_{amb} = 25\text{ °C}$, unless otherwise specified

Minimum and maximum values are testing requirements. Typical values are characteristics of the device and are the result of engineering evaluation. Typical values are for information only and are not part of the testing requirements.

Input

Parameter	Test condition	Symbol	Min	Typ.	Max	Unit
Forward voltage	$I_F = 20\text{ mA}$	V_F		1.2	1.5	V
Reverse voltage	$I_R = 10\text{ }\mu\text{A}$	V_R	5.0			V
Reverse current	$V_R = 5.0\text{ V}$	I_R			10	μA

Output

Parameter	Test condition	Symbol	Min	Typ.	Max	Unit
Forward blocking voltage	$R_{GK} = 10\text{ K}\Omega, T_A = 100\text{ °C}, I_d = 150\text{ }\mu\text{A}$	V_{DRM}	400			V
Reverse blocking voltage	$R_{GK} = 10\text{ K}\Omega, T_A = 100\text{ °C}, I_d = 150\text{ }\mu\text{A}$	V_{DRRM}	400			V
On-state voltage	$I_T = 100\text{ mA}$	V_t			1.2	V
Holding current	$R_{GK} = 27\text{ K}\Omega, V_{FX} = 50\text{ V}$	I_H			500	μA
Gate trigger voltage	$V_{FX} = 100\text{ V}, R_{GK} = 27\text{ K}\Omega, R_L = 10\text{ K}\Omega$	V_{GT}		0.6	1.0	V
Forward leakage current	$R_{GK} = 27\text{ K}\Omega, I_F = 0$	I_D		0.2	2.0	μA
Reverse leakage current	$R_{GK} = 27\text{ K}\Omega, I_F = 0$	I_R		0.2	2.0	μA
Gate trigger current	$V_{FX} = 100\text{ V}, R_{GK} = 27\text{ K}\Omega, R_L = 10\text{ K}\Omega$	I_{GT}		20	50	μA

Coupler

Parameter	Test condition	Symbol	Min	Typ.	Max	Unit
Turn-on current	$V_{FX} = 100\text{ V}$	I_{FT}	0.5	5.0	10.0	mA
Capacitance (input-output)	$f = 1.0\text{ MHz}$	C_{IO}			2	pF

Package Dimensions in Inches (mm)

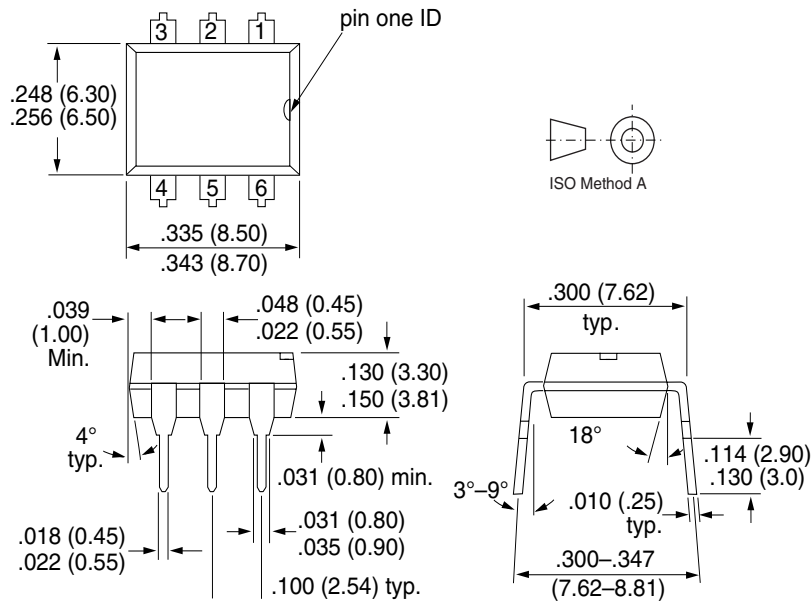

i178004

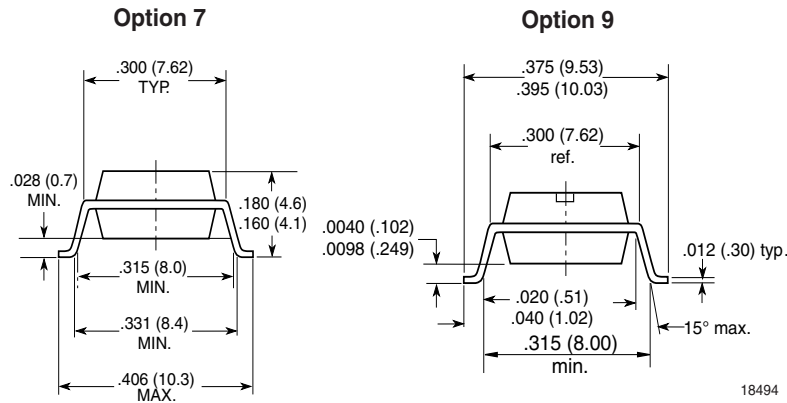

18494

Ozone Depleting Substances Policy Statement

It is the policy of Vishay Semiconductor GmbH to

1. Meet all present and future national and international statutory requirements.
2. Regularly and continuously improve the performance of our products, processes, distribution and operating systems with respect to their impact on the health and safety of our employees and the public, as well as their impact on the environment.

It is particular concern to control or eliminate releases of those substances into the atmosphere which are known as ozone depleting substances (ODSs).

The Montreal Protocol (1987) and its London Amendments (1990) intend to severely restrict the use of ODSs and forbid their use within the next ten years. Various national and international initiatives are pressing for an earlier ban on these substances.

Vishay Semiconductor GmbH has been able to use its policy of continuous improvements to eliminate the use of ODSs listed in the following documents.

1. Annex A, B and list of transitional substances of the Montreal Protocol and the London Amendments respectively
2. Class I and II ozone depleting substances in the Clean Air Act Amendments of 1990 by the Environmental Protection Agency (EPA) in the USA
3. Council Decision 88/540/EEC and 91/690/EEC Annex A, B and C (transitional substances) respectively.

Vishay Semiconductor GmbH can certify that our semiconductors are not manufactured with ozone depleting substances and do not contain such substances.

We reserve the right to make changes to improve technical design
and may do so without further notice.

Parameters can vary in different applications. All operating parameters must be validated for each customer application by the customer. Should the buyer use Vishay Semiconductors products for any unintended or unauthorized application, the buyer shall indemnify Vishay Semiconductors against all claims, costs, damages, and expenses, arising out of, directly or indirectly, any claim of personal damage, injury or death associated with such unintended or unauthorized use.

Vishay Semiconductor GmbH, P.O.B. 3535, D-74025 Heilbronn, Germany
Telephone: 49 (0)7131 67 2831, Fax number: 49 (0)7131 67 2423