

HSMx-A43x-xxxxx

Surface Mount LED Indicator



Description

The Broadcom[®] Power PLCC-4 SMT LEDs with Lens are high-performance PLCC-4 package size SMT LEDs targeted mainly in Automotive and Electronic Signs and Signals (ESS) markets. These top-mount single-chip packages with focused radiation offer high brightness in beam direction and are excellent for interior automotive, indoor and outdoor sign and industrial applications. With additional lens in 30° variants, these products are especially fitting to applications for traffic lights, CHMSL, and displays.

The PLCC-4 package family is able to dissipate heat better compared to the PLCC-2 packages. In proportion to this increase in driving current, this family of LEDs is able to produce higher light output compared to the conventional PLCC-2 SMT LEDs.

As an extension of the standard flat top PLCC-4 SMT LEDs, the Power PLCC-4 with Lens device is able to provide focused beams within narrow viewing angles (30°) meeting the market's requirements for focused radiation and high brightness in beam directions.

The Power PLCC-4 SMT LED with 30° is ideal for panel, push button, or general backlighting in automotive interior and exterior, sign, office equipment, industrial equipment, and home appliances applications. This package design, coupled with careful selection of component materials, allows the Power PLCC-4 SMT LED with Lens to perform with higher reliability in a larger temperature range -40 °C to 100 °C. This high reliability feature is crucial to allow the Power PLCC-4 SMT LED with Lens to perform well in harsh environments, such as its target Automotive and ESS markets. The Power PLCC-4 SMT LED with Lens package is also designed to be compatible with both IR-solder re-flow and through-the-wave soldering.

CAUTION!

This LED is ESD sensitive. Please observe appropriate precautions during handling and processing. Refer to application note AN-1142 for additional details.

Features

- Industry-standard PLCC-4
- High reliability LED package
- High brightness using AlInGaP and InGaN dice technologies
- High optical efficiency
- Narrow viewing angle at 30°
- Available in 8-mm carrier tape on 7-inch reel
- Compatible with both IR and TTW soldering process

Applications

Interior automotive:

- Instrument panel backlighting
- Central console backlighting
- Cabin backlighting
- Navigation and audio system
- Dome lighting
- Push button backlighting

Exterior automotive:

- Turn signals
- CHMSL
- Rear combination lamp
- Side repeaters

Electronic signs and signals:

- Interior and exterior full color sign
- Variable message sign
- Garden lighting

Office automation, home appliances, industrial equipment:

- Front panel backlighting
- Push button backlighting
- Display backlighting

The Broadcom Power PLCC-4 SMT LED with 30° Lens carries the part number HSMx- A43x-xxxxx. The high brightness AllnGaP and InGaN dice technologies used provide the product brightness that meets the Automotive and ESS market requirements. The lens package will complement and complete the existing AllnGaP and InGaN color standard Power-PLCC-4 LED that Broadcom offers, providing customers an extra lens option from one supplier.

To facilitate easy pick and place assembly, the LEDs are packed in EIA-compliant tape and reel. Every reel is shipped in single intensity and color bin (except for red color), to provide close uniformity.

Figure 1: Package Dimensions Source A

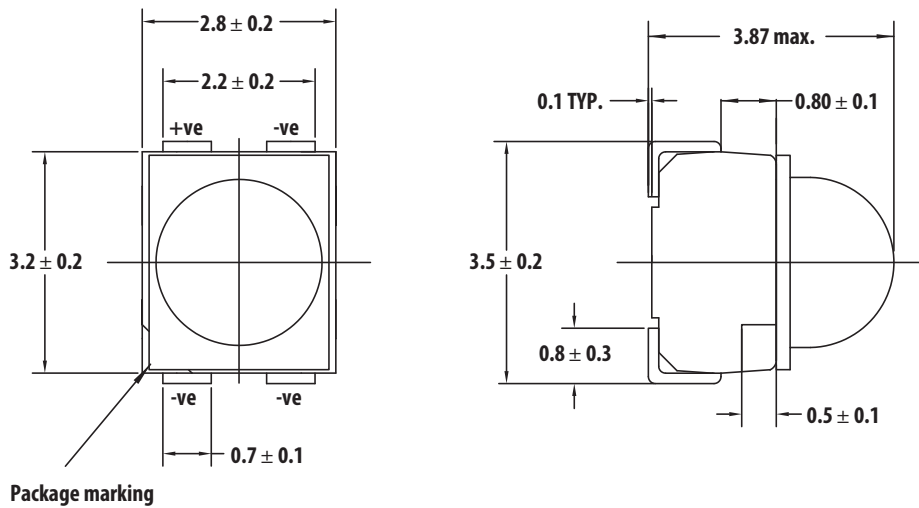
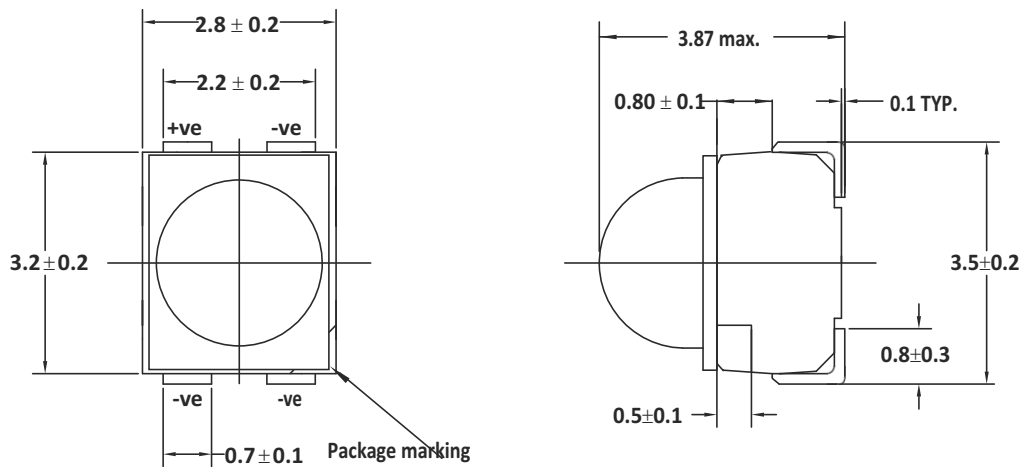

Figure 2: Package Dimensions Source B



NOTE:

1. All dimensions are in mm.
2. Electrical connection between all cathodes is recommended.

Device Selection Guide

Color	Part Number	Min. I_V (mcd)	Typ. I_V (mcd)	Max. I_V (mcd)	Test Current (mA)	Dice Technology
Red	HSMC-A430-W50M1	1125	2300	3550	50	AllnGaP
	HSMC-A431-X90M1	2240	4000	7150	50	AllnGaP
	HSMC-A431-Y70M1	3550	—	7150	50	AllnGaP
	HSMC-A431-Y80M1	3550	—	9000	50	AllnGaP
Red Orange	HSMJ-A430-W50M1	1125	2300	3550	50	AllnGaP
	HSMJ-A431-X90M1	2240	4500	7150	50	AllnGaP
	HSMJ-A431-X90M1	2240	—	7150	50	AllnGaP
	HSMJ-A431-Y70M1	3550	—	7150	50	AllnGaP
Orange	HSML-A431-X90M1	2240	4500	7150	50	AllnGaP
Amber	HSMA-A430-W90M1	1400	3000	4500	50	AllnGaP
	HSMA-A431-Y00M1	2850	5000	—	50	AllnGaP
	HSMA-A431-X90M1	2240	4700	7150	50	AllnGaP
	HSMA-A431-13NM1	7150	—	14000	50	AllnGaP
	HSMA-A431-Z50M1	4500	—	14000	50	AllnGaP
	HSMA-A431-Z5WM1	4500	—	14000	50	AllnGaP
Green	HSMM-A430-X90M2	2240	—	7150	30	InGaN
	HSMM-A430-Y3YM2	2850	—	5600	30	InGaN
	HSMM-A430-Y7YM2	3550	—	7150	30	InGaN
Blue	HSMN-A430-V50M2	715	—	2240	30	InGaN
	HSMN-A430-V7YM2	900	—	1800	30	InGaN

NOTE:

1. The luminous intensity, I_V , is measured at the mechanical axis of the lamp package. The actual peak of the spatial radiation pattern might not be aligned with this axis.
2. I_V tolerance is $\pm 12\%$.

Part Numbering System

H S M x₁ - A x₂ x₃ x₄ - x₅ x₆ x₇ x₈ x₉

Code	Description	Option
X ₁	LED Chip Color	C Red
		J Red Orange
		L Orange
		A Amber
		M Green
		N Blue
X ₂	Package Type	4 PLCC-4
X ₃ X ₄	Device Specific Configuration	
X ₅	Minimum Intensity Bin Limits	Refer Intensity Bin Limit
X ₆	Intensity Bin Select	0 Full Distribution
		2 2 half bins starting from X ₅ 1
		3 3 half bins starting from X ₅ 1
		4 4 half bins starting from X ₅ 1
		5 5 half bins starting from X ₅ 1
		6 2 half bins starting from X ₅ 2
		7 3 half bins starting from X ₅ 2
		8 4 half bins starting from X ₅ 2
		9 5 half bins starting from X ₅ 2
X ₇	Color Bin Select	0 Full Distribution
		Z A and B only
		Y B and C only
		W C and D only
		V D and E only
		U E and F only
		T F and G only
		S G and H only
		Q A, B and C only
		P B, C and D only
		N C, D and E only
		M D, E and F only
		L E, F and G only
		K F, G and H only
1 A, B, C and D only		
2 E, F G and H only		
X ₈ X ₉	Packaging Option	M1 50-mA test current, top mount, 13 inch reel size
		M2 30-mA test current, top mount, 13 inch reel size

Intensity Bin Limits

Bin ID	Min. I_V (mcd)	Max. I_V (mcd)
U1	450.00	560.00
U2	560.00	715.00
V1	715.00	900.00
V2	900.00	1125.00
W1	1125.00	1400.00
W2	1400.00	1800.00
X1	1800.00	2240.00
X2	2240.00	2850.00
Y1	2850.00	3550.00
Y2	3550.00	4500.00
Z1	4500.00	5600.00
Z2	5600.00	7150.00
11	7150.00	9000.00
12	9000.00	11250.00
21	11250.00	14000.00
22	14000.00	18000.00

Tolerance of each bin limit = $\pm 12\%$.

Color Bin Limits

Blue	Min. (nm)	Max. (nm)
A	460.0	465.0
B	465.0	470.0
C	470.0	475.0
D	475.0	480.0

Cyan	Min. (nm)	Max. (nm)
A	490.0	495.0
B	495.0	500.0
C	500.0	505.0
D	505.0	510.0

Green	Min. (nm)	Max. (nm)
A	515.0	520.0
B	520.0	525.0
C	525.0	530.0
D	530.0	535.0

Amber	Min. (nm)	Max. (nm)
A	582.0	584.5
B	584.5	587.0
C	587.0	589.5
D	589.5	592.0
E	592.0	594.5
F	594.5	597.0

Orange	Min. (nm)	Max. (nm)
A	597.0	600.0
B	600.0	603.0
C	603.0	606.0
D	606.0	609.0
E	609.0	612.0

Red/ Orange	Min. (nm)	Max. (nm)
A	611.0	616.0
B	616.0	620.0

Red	Min. (nm)	Max. (nm)
Full Distribution		

Forward Voltage Bin Table

For HSMV-A43x-xxxxx only.

Bin	Min. (V)	Max. (V)
VA	1.9	2.2
VB	2.2	2.5
VC	2.5	2.8
VD	2.8	3.1
VE	3.1	3.4

Tolerance for each bin limit = $\pm 0.1V$.

Absolute Maximum Ratings ($T_A = 25^\circ\text{C}$)

Parameters	HSMC/A	HSMV	HSMK/M/N	Unit
DC Forward Current ^a	70	70	30	mA
Peak Forward Current ^b	200	200	90	mA
Power Dissipation	180	240	114	mW
Reverse Voltage	5	5	4	V
Junction Temperature	110			$^\circ\text{C}$
Operating Temperature	-40 to +100			$^\circ\text{C}$
Storage Temperature	-40 to +100			$^\circ\text{C}$

a. Derate linearly as shown in Figure 7 and Figure 8.

b. Duty factor = 10%, frequency = 1 kHz.

Optical Characteristics ($T_A = 25^\circ\text{C}$)

Color	Part Number	Dice Technology	Peak Wavelength, λ_{PEAK} (nm)	Dominant Wavelength, λ_{D} ^a (nm)	Viewing Angle, $2\theta_{1/2}$ ^b (Degrees)	Luminous Efficacy, η_{V} ^c (lm/W)
			Typical	Typical	Typical	Typical
Red	HSMC-A43x	AllnGaP	635	626	30	150
Red Orange	HSMJ-A43x	AllnGaP	621	615	30	240
	HSMV-A430	AllnGaP	623	617	30	263
Orange	HSML-A431	AllnGaP	609	605	30	320
Amber	HSMA-A43x	AllnGaP	592	590	30	480
Green	HSMM-A430	InGaN	518	525	30	500
Blue	HSMN-A43X	InGaN	468	470	30	75
Cyan	HSMK-A43X	InGaN	500	502	30	285

a. The dominant wavelength, λ_{D} , is derived from the CIE Chromaticity Diagram and represents the color of the device.

b. $\theta_{1/2}$ is the off-axis angle where the luminous intensity is $1/2$ the peak intensity.

c. Radiant intensity, I_e in watts/steradian, may be calculated from the equation $I_e = I_{\text{V}}/\eta_{\text{V}}$, where I_{V} is the luminous intensity in candelas and η_{V} is the luminous efficacy in lumens/watt.

Electrical Characteristics ($T_A = 25^\circ\text{C}$)

Part Number	Forward Voltage, V_{F} (Volts) at $I_{\text{F}} = 50 \text{ mA}$			Reverse Voltage, V_{R} at $100 \mu\text{A}$	Reverse Voltage, V_{R} at $10 \mu\text{A}$
	Min.	Typ.	Max.	Min.	Min.
HSMC/J/L/A	1.7	2.2	2.5	5	—
HSMV	1.7	2.8	3.4	5	—

Part Number	Forward Voltage V_{F} (Volts) at $I_{\text{F}} = 30 \text{ mA}$			Reverse Voltage V_{R} at $100 \mu\text{A}$	Reverse Voltage V_{R} at $10 \mu\text{A}$
	Minimum	Typical	Maximum	Minimum	Minimum
HSMK/M/N	2.7	3.9	4.6	—	5

Figure 3: Relative Intensity vs. Wavelength

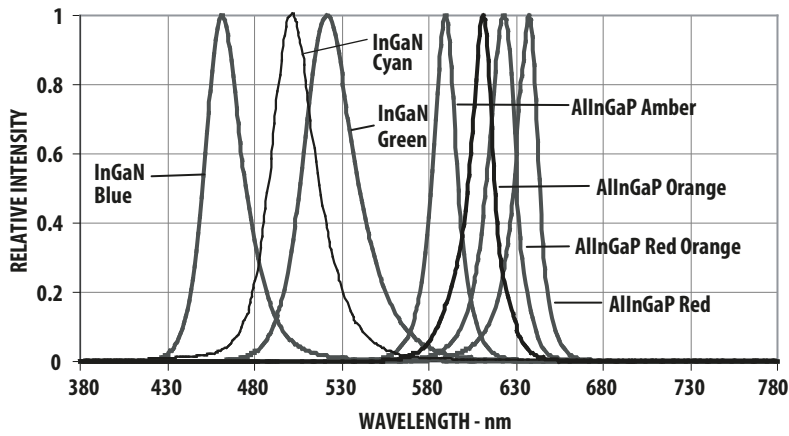

Figure 4: Forward Current vs. Forward Voltage

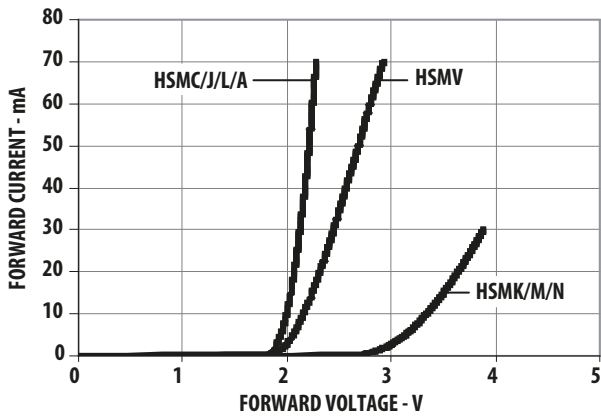

Figure 5: Relative Intensity vs. Forward Current (AllInGaP)

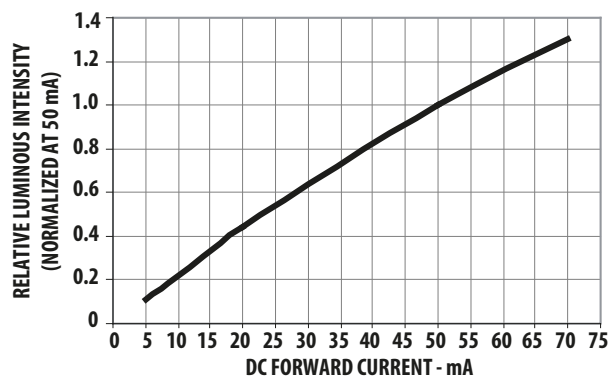

Figure 6: Relative Intensity vs. Forward Current (InGaN)

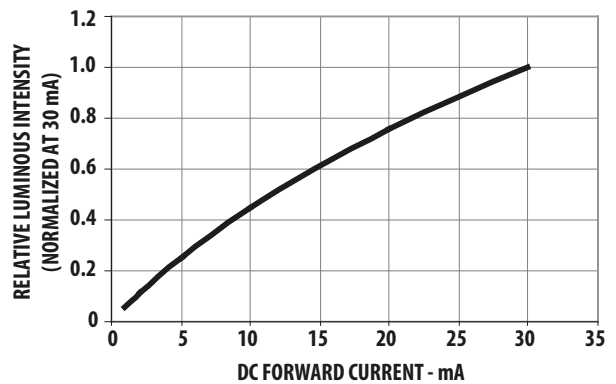

Figure 7: Maximum Forward Current vs. Ambient Temperature. Derated Based on $T_{Jmax} = 110\text{ }^{\circ}\text{C}$ (AlInGaP)

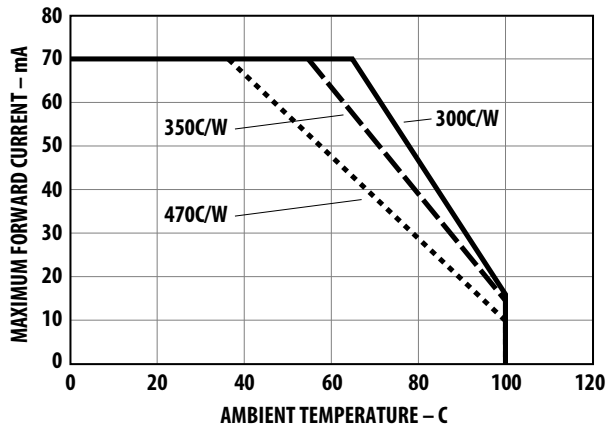

Figure 8: Maximum Forward Current vs. Ambient Temperature. Derated Based on $T_{Jmax} = 110\text{ }^{\circ}\text{C}$ (InGaN)

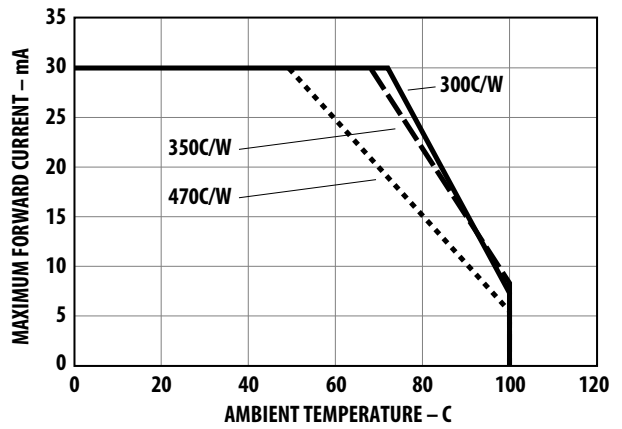

Figure 9: Radiation Pattern

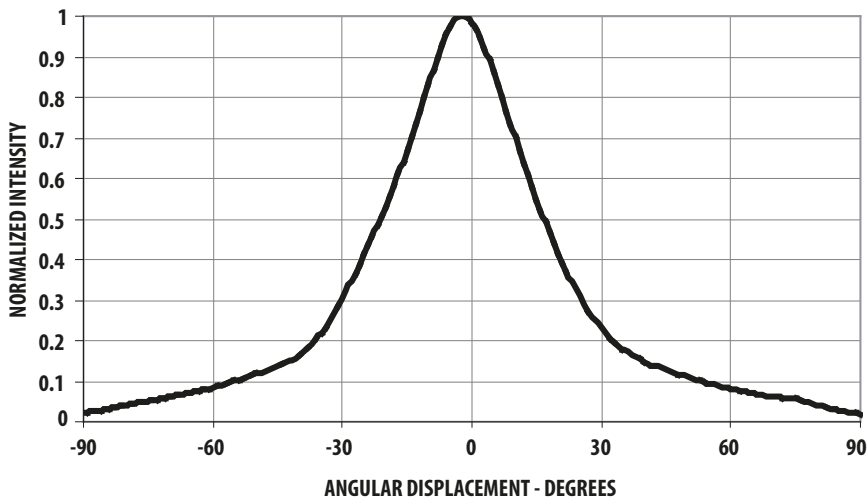

Figure 10: Recommended Soldering Pad Pattern (IR Reflow)

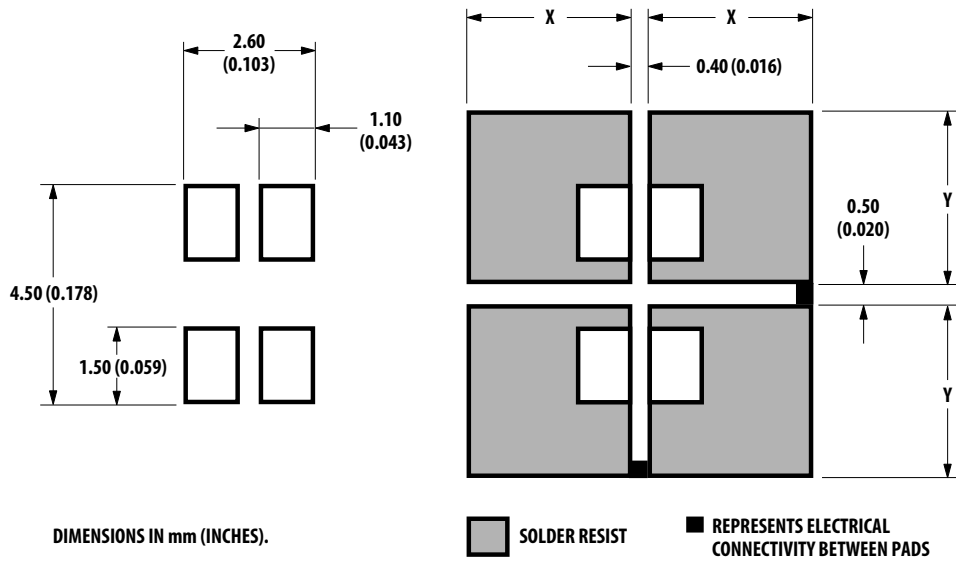

Figure 11: Recommended Soldering Pad Pattern (TTW)

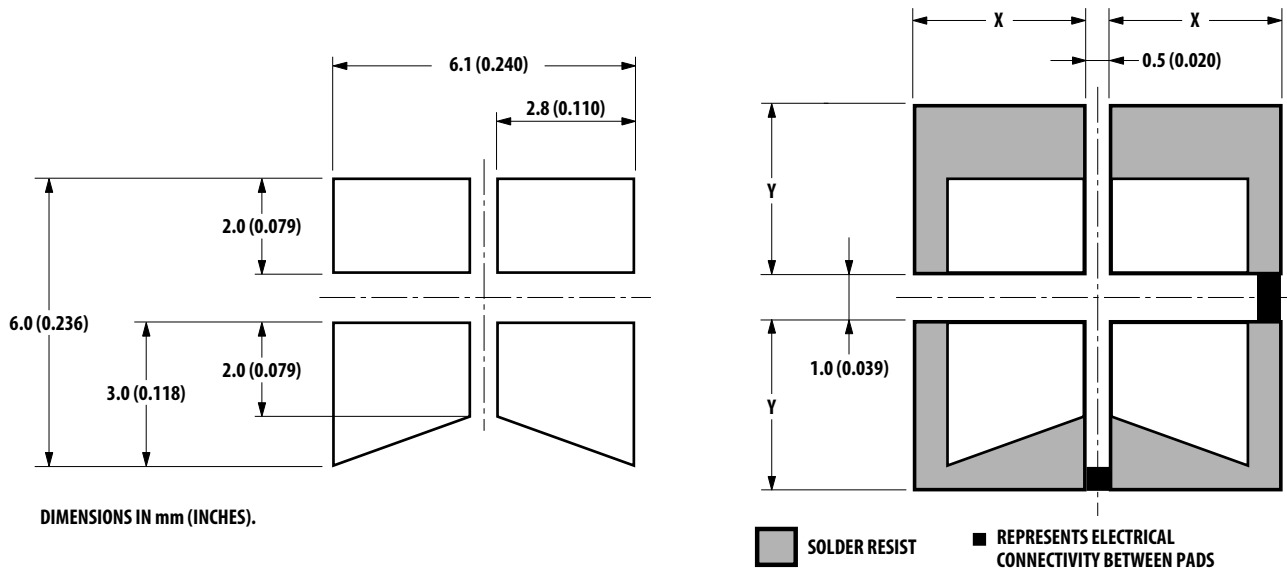

Figure 12: Soft Tip Vacuum Pick-Up Tool for Extracting SMD LED Components from Carrier Tape

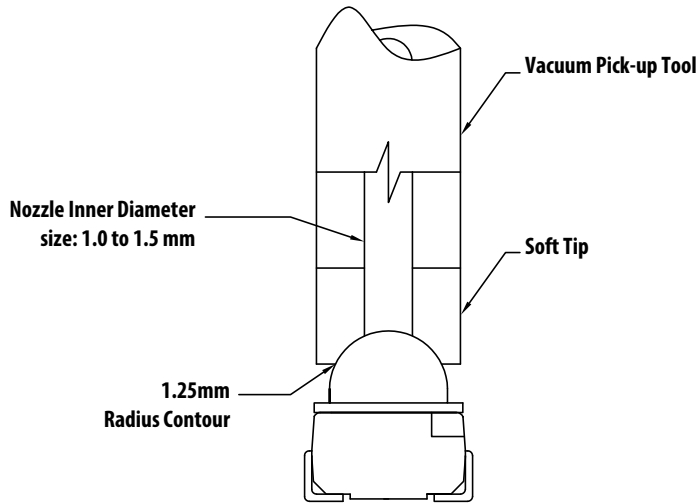

Figure 13: Recommended Pb-Free Reflow Soldering Profile

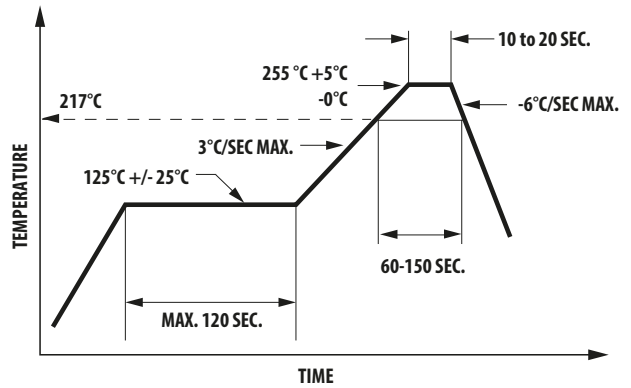

Figure 14: Recommended Wave Soldering Profile

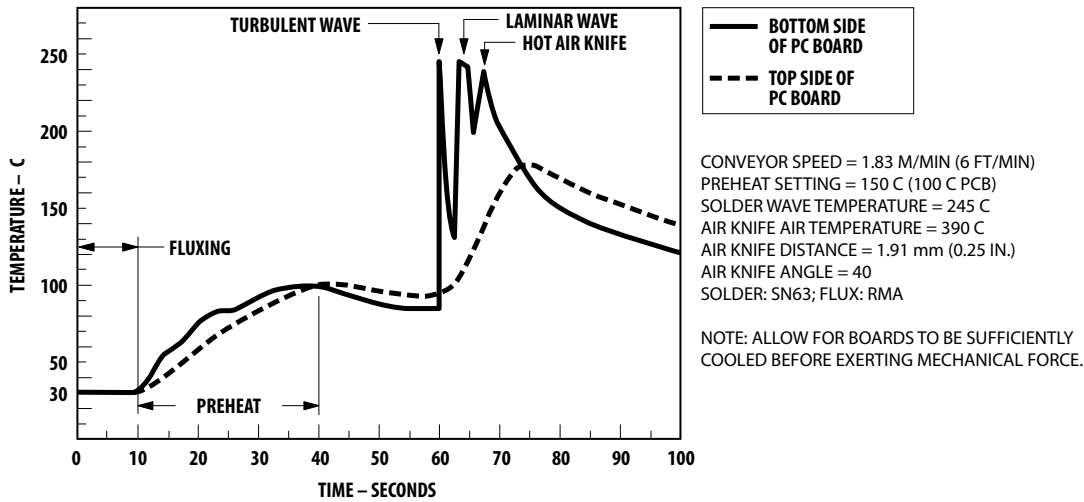

Figure 15: Tape Leader and Trailer Dimensions

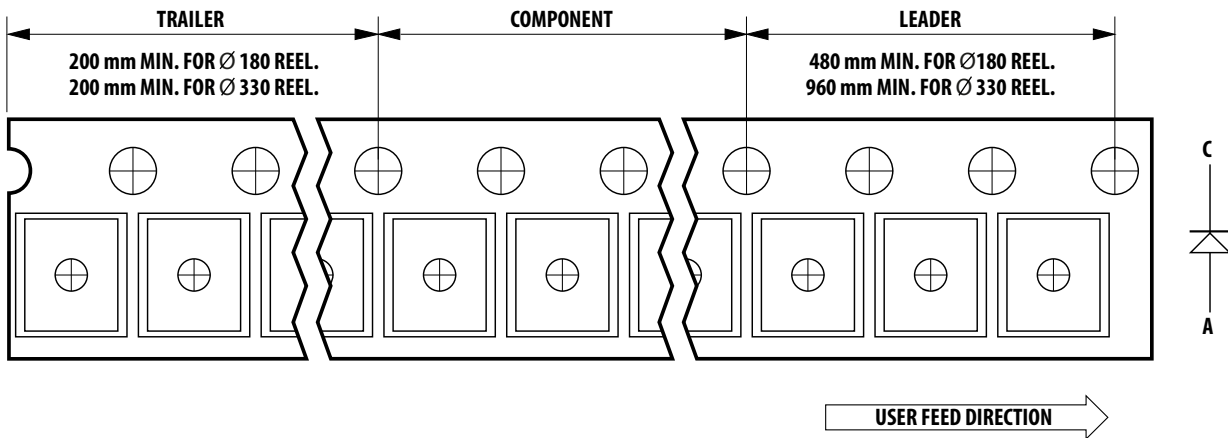

Figure 16: Tape Dimensions

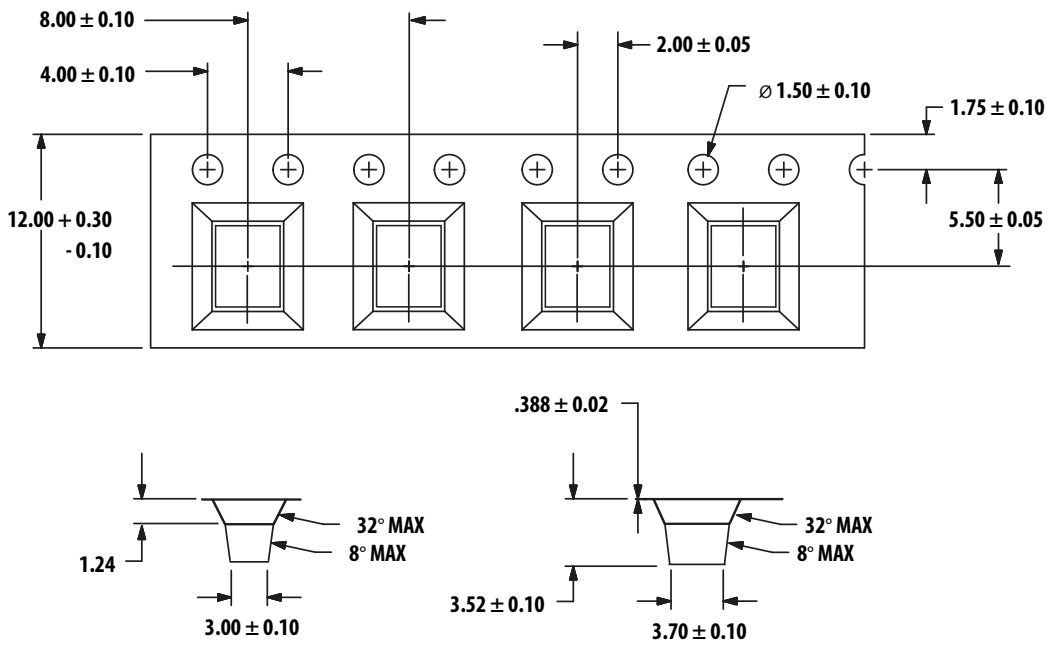
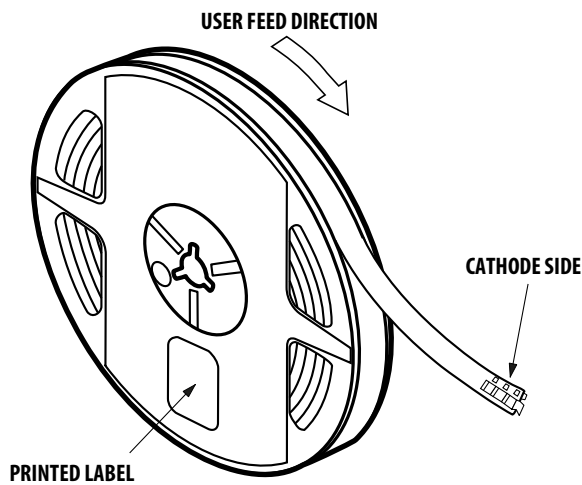

Figure 17: Reeling Orientation

Handling of Moisture-Sensitive Devices

This product is qualified as Moisture Sensitive Level 2a per JEDEC J-STD-020. The following precautions for handling this moisture-sensitive product will help to ensure the reliability of the product. Refer to Broadcom Application Note AN5305, *Handling of Moisture Sensitive Surface Mount Devices*, for details.

- Before use:
 - An unopened moisture barrier bag (MBB) can be stored at $40^{\circ}\text{C}/90\% \text{RH}$ for 12 months. If the actual shelf life has exceeded 12 months and the humidity indicator card (HIC) indicates that baking is not required, it is safe to reflow the LEDs per the original MSL rating.
 - Do not open the MBB prior to assembly (for example, for IQC).
- Control after opening the MBB:
 - Read the HIC immediately upon opening of MBB.
 - Keep the LEDs at $30^{\circ}\text{C}/60\% \text{RH}$ at all times, and complete all high temperature-related processes, including soldering, curing, or rework within 672 hours.
- Control for unfinished reel:

Store unused LEDs in a sealed MBB with desiccant or a desiccator at $5\% \text{RH}$.

- Control of assembled boards:

If the PCB soldered with the LEDs is to be subjected to other high-temperature processes, store the PCB in a sealed MBB with desiccant or desiccator at $5\% \text{RH}$ to ensure that all LEDs have not exceeded their floor life of 672 hours.
- Baking is required if:
 - The HIC indicator indicates a change in color for 10% and 5%, as stated on the HIC.
 - The LEDs are exposed to conditions of $30^{\circ}\text{C}/60\% \text{RH}$ at any time.
 - The LED's floor life exceeded 672 hours.

The recommended baking condition is $60^{\circ}\text{C} \pm 5^{\circ}\text{C}$ for 20 hours.

Baking can only be done once.

Broadcom, the pulse logo, Connecting everything, Avago Technologies, Avago, and the A logo are among the trademarks of Broadcom and/or its affiliates in the United States, certain other countries and/or the EU.

Copyright © 2017 by Broadcom. All Rights Reserved.

The term “Broadcom” refers to Broadcom Limited and/or its subsidiaries. For more information, please visit www.broadcom.com.

Broadcom reserves the right to make changes without further notice to any products or data herein to improve reliability, function, or design. Information furnished by Broadcom is believed to be accurate and reliable. However, Broadcom does not assume any liability arising out of the application or use of this information, nor the application or use of any product or circuit described herein, neither does it convey any license under its patent rights nor the rights of others.



Lead (Pb) Free
RoHS 6 fully
compliant