

HSMF-C113 and HSMF-C115

Right Angle Tricolor Surface Mount ChipLEDs



Data Sheet

Description

The HSMF-C113 / C115 tricolor chip-type LED is designed in an ultra small package for miniaturization. It is the first of its kind to achieve such small packaging for 3 dies. With the freedom to have any combination of colors from mixing of the 3 primary colors, this will yield a wide variety of colors to suit every application and product theme.

The small size, narrow footprint, and low profile make this LED excellent for back-lighting, status indication, and front panel illumination applications.

In order to facilitate pick and place operation, this ChipLED is shipped in tape and reel, with 3000 units per reel. The package is compatible with reflow soldering and binned by both color and intensity.

Features

- Common anode
- Small 2.5 x 1.0 x 1.0 mm package
- Diffused optics
- Available in 8 mm tape on 7" diameter reels
- High brightness using AlInGaP and InGaN die technology
- Compatible with reflow soldering

Applications

- Backlighting
- Status indicator
- Front panel indicator
- Office automation, home appliances, industrial equipment

Device Selection Guide

Part Number	Color	Package Description
HSMF-C113	AlInGaP Red / AlInGaP Green / InGaN Blue	Untinted, Diffused
HSMF-C115	AlInGaP Red / InGaN Green / InGaN Blue	Untinted, Diffused

CAUTION: HSMF-C113 and HSMF-C115 LEDs are Class 1A ESD sensitive per JESD22-A114C.01. Please observe appropriate precautions during handling and processing. Refer to Avago Technologies Application Note AN-1142 for additional details.

Package Dimensions

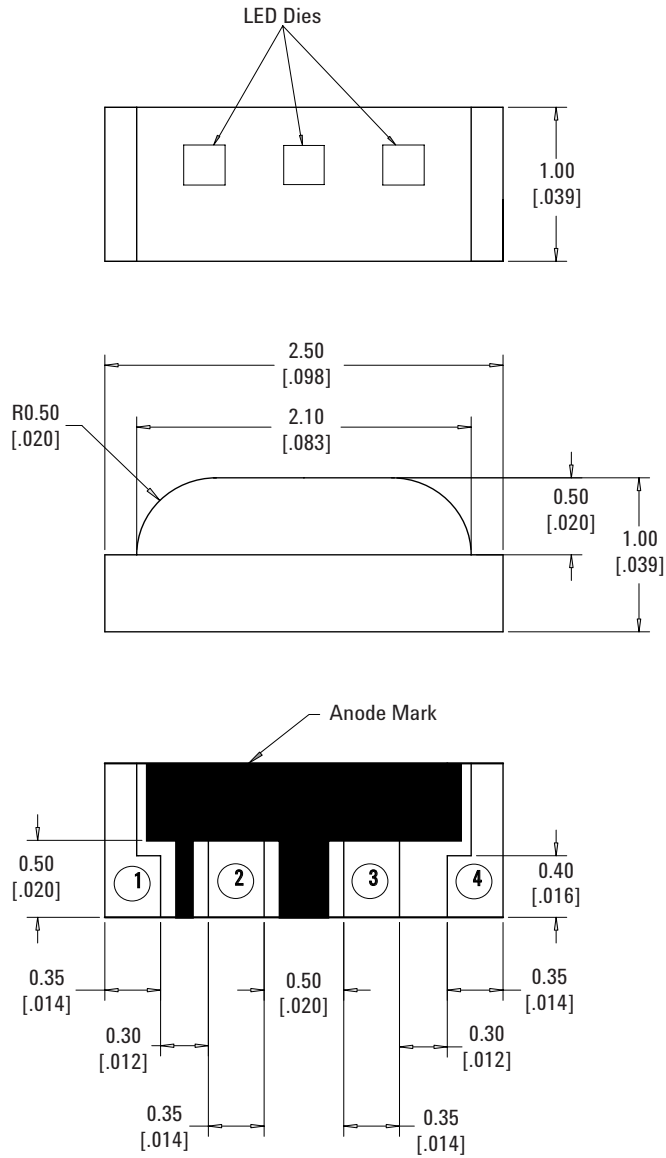

Notes:

1. All Dimensions in millimetres (inches)
2. Tolerance is $\pm 0.1\text{mm}$ ($\pm 0.004\text{ in}$) unless otherwise specified

POLARITY	HSMF-C113	HSMF-C115
	InGaN BLUE	InGaN BLUE
	AllInGaP RED	AllInGaP RED
	AllInGaP GREEN	InGaN GREEN

Absolute Maximum Ratings at $T_A = 25^\circ\text{C}$

Parameter	AllInGaP Red	AllInGaP Green	InGaN Green	InGaN Blue	Units
DC Forward Current ^[1,3]	20	20	20	20	mA
Power Dissipation ^[1]	48	52	78	78	mW
DC Forward Current ^[2]	15	15	15	15	mA
Power Dissipation ^[2]	36	39	59	59	mW
Reverse Voltage ($I_R = 100\text{mA}$)	5	5	5	5	V
LED Junction Temperature	95	95	95	95	$^\circ\text{C}$
Operating Temperature Range	-40 to +85				$^\circ\text{C}$
Storage Temperature Range	-40 to +85				$^\circ\text{C}$
Soldering Temperature	See IR soldering profile (Figure 6 & 7)				

Notes:

1. Applies when single LED is lit up.
2. Applies when all 3 LEDs are lit up simultaneously.
3. Derate linearly as shown in Figure 4.
4. Drive currents above 5 mA are recommended for best long term performance.

Electrical Characteristics at $T_A = 25^\circ\text{C}$

Part Number	Forward Voltage VF (Volts) ^[1] @ $I_F = 20\text{mA}$		Reverse Breakdown VR (Volts) @ $I_R = 100\text{mA}$	Capacitance C (pF), @ $V_F = 0, f = 1\text{MHz}$	Thermal Resistance $R_{\theta J-PIN}$ ($^\circ\text{C/W}$)
	Typ.	Max.	Min.	Typ.	Typ.
AllInGaP Red	1.9	2.0	5	12	550
AllInGaP Green	2.0	2.6	5	15	300
InGaN Green	3.4	3.9	5	65	400
InGaN Blue	3.4	3.9	5	65	400

Notes:

1. Vf tolerance : $\pm 0.1\text{V}$

Optical Characteristics at $T_A = 25^\circ\text{C}$

Part Number	Luminous Intensity I_V ^[1] (mcd) @ 20mA		Peak Wavelength λ_{peak} (nm)	Color, Dominant Wave- length λ_d ^[2] (nm)	Viewing Angle $2\theta_{1/2}$ ^[3] (Degrees)	Luminous Ef- ficacy η_V (lm/W)
	Min.	Typ.	Typical	Typical	Typical	Typical
AllInGaP Red	28.5	80.0	637	626	120	155
AllInGaP Green	18.0	50.0	570	572	125	570
InGaN Green	71.5	170.0	523	525	125	443
InGaN Blue	28.5	60.0	468	470	125	89

Notes:

1. The luminous intensity I_V is measured at the peak of the spatial radiation pattern which may not be aligned with the mechanical axis of the LED package.
2. The dominant wavelength, λ_d , is derived from the CIE Chromaticity Diagram and represents the perceived color of the device.
3. $\theta_{1/2}$ is the off-axis angle where the luminous intensity is $\frac{1}{2}$ the peak intensity.

CAUTION:

1. The above optical performance specifications are valid in the case when single LED is lit up.
2. The above product specifications DO NOT provide any guarantee on color mixing, color consistency over time, or uniformity in luminous intensity when more than 1 LED is lit.
3. Please refer to Avago Technologies Application Brief AB D-007 for additional details / explanation on driving the part in parallel circuit.

Light Intensity (I_v) Bin Limits^[1]

Bin ID	Intensity (mcd)	
	Minimum	Maximum
A	0.11	0.18
B	0.18	0.29
C	0.29	0.45
D	0.45	0.72
E	0.72	1.10
F	1.10	1.80
G	1.80	2.80
H	2.80	4.50
J	4.50	7.20
K	7.20	11.20
L	11.20	18.00
M	18.00	28.50
N	28.50	45.00
P	45.00	71.50
Q	71.50	112.50
R	112.50	180.00
S	180.00	285.00
T	285.00	450.00

Tolerance : ±15%

Notes:

1. Bin categories are established for classification of products. Products may not be available in all categories. Please contact your Avago Technologies representative for information on current available bins.

AllnGaP Red Color Bin Limits^[1]

Bin ID	Dom. Wavelength (nm)	
	Minimum	Maximum
--	620.0	635.0

Tolerance : ±1nm

AllnGaP Green Color Bin Limits^[1]

Bin ID	Dom. Wavelength (nm)	
	Minimum	Maximum
A	561.5	564.5
B	564.5	567.5
C	567.5	570.5
D	570.5	573.5
E	573.5	576.5

Tolerance : ±1nm

InGaN Green Color Bin Limits^[1]

Bin ID	Dom. Wavelength (nm)	
	Minimum	Maximum
A	515.0	520.0
B	520.0	525.0
C	525.0	530.0
D	530.0	535.0

Tolerance : ±1nm

InGaN Blue Color Bin Limits^[1]

Bin ID	Dom. Wavelength (nm)	
	Minimum	Maximum
A	460.0	465.0
B	465.0	470.0
C	470.0	475.0
D	475.0	480.0

Tolerance : ±1nm

Notes:

1. Bin categories are established for classification of products. Products may not be available in all categories. Please contact your Avago Technologies representative for information on current available bins.

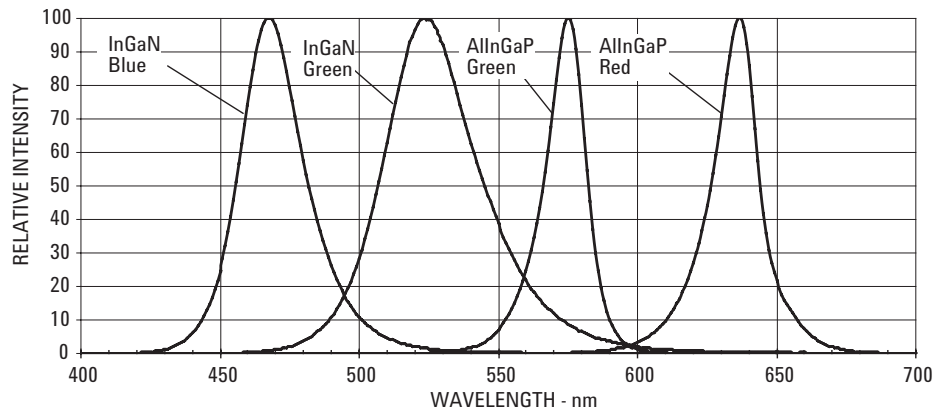

Figure 1. Relative intensity vs. wavelength.

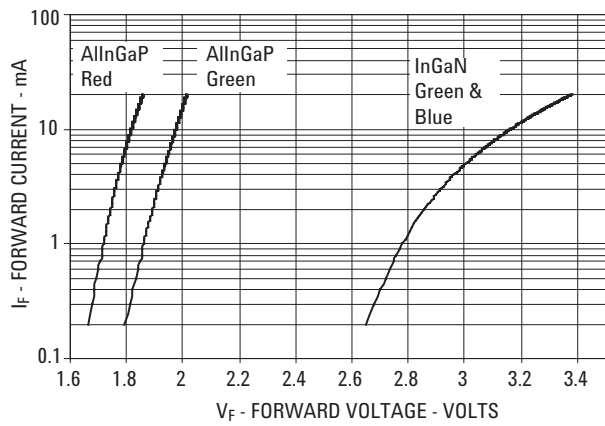

Figure 2. Forward current vs. forward voltage.

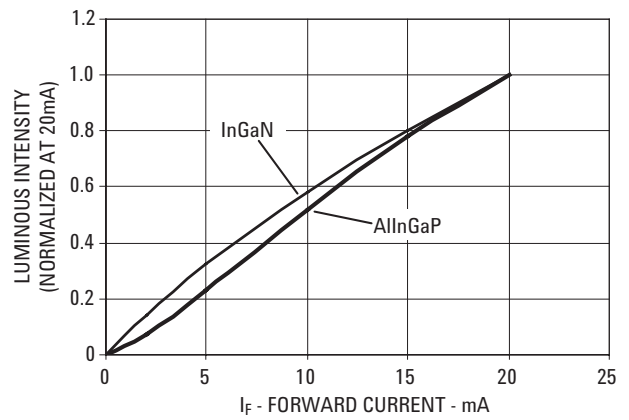

Figure 3. Luminous intensity vs. forward current.

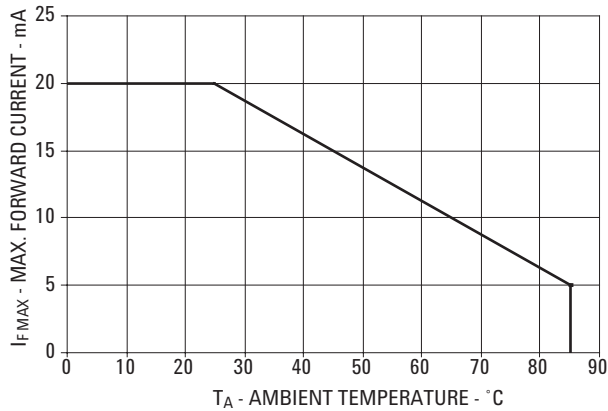

Figure 4. Maximum forward current vs. ambient temperature.

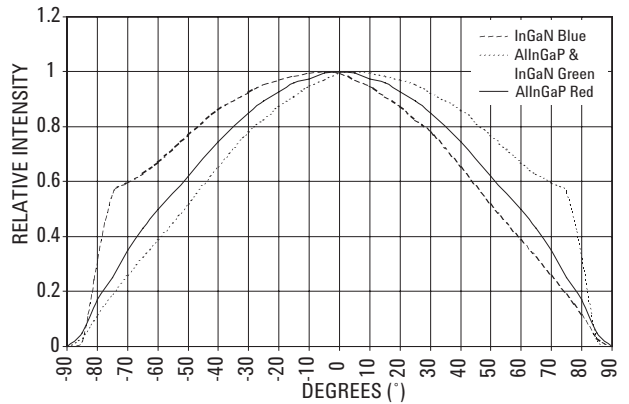

Figure 5. Relative intensity vs. angle.

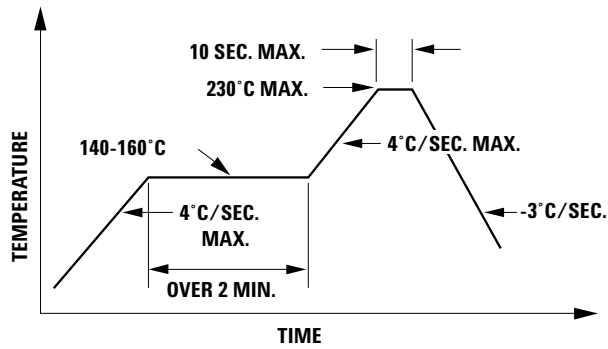
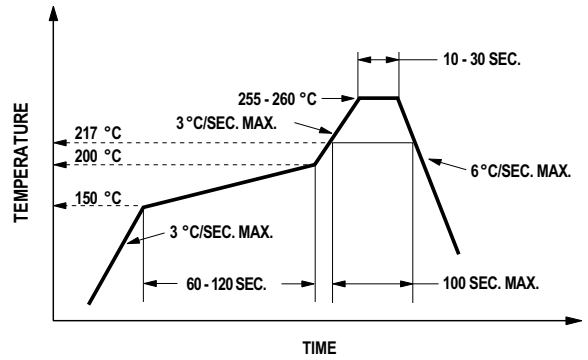

Figure 6. Recommended reflow soldering profile.



(Acc. to J-STD-020C)

Figure 7. Recommended Pb-free reflow soldering profile.

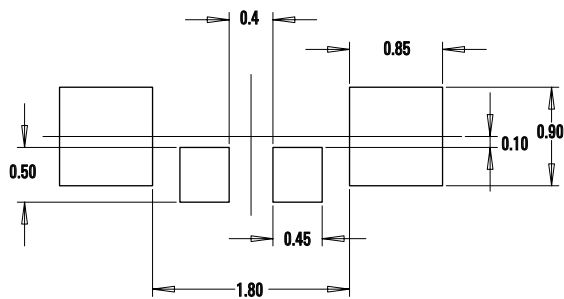

Figure 8. Recommended soldering land pattern.

Notes:

1. All dimensions are in millimeters (inches).
2. Tolerance is $\pm 0.1\text{mm}$ ($\pm 0.004\text{in.}$) unless otherwise specified.

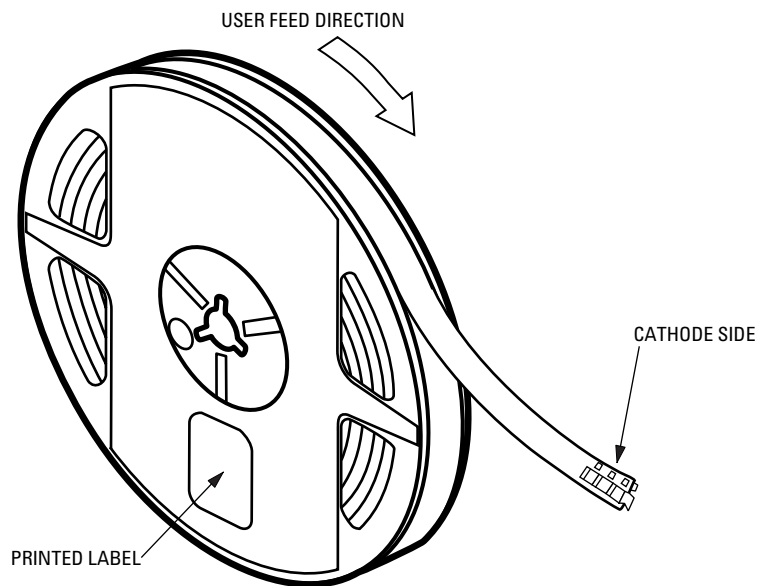
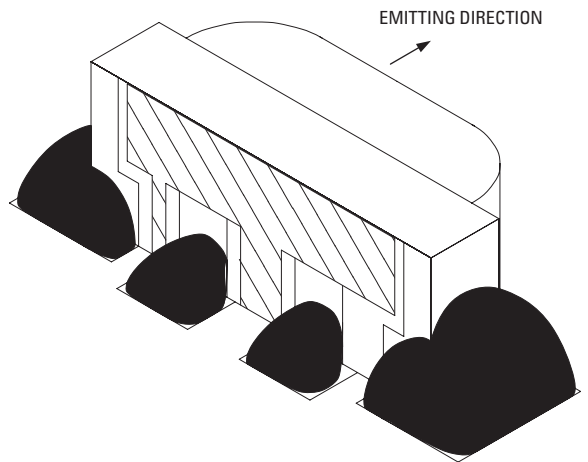

Figure 9. Reeling orientation.

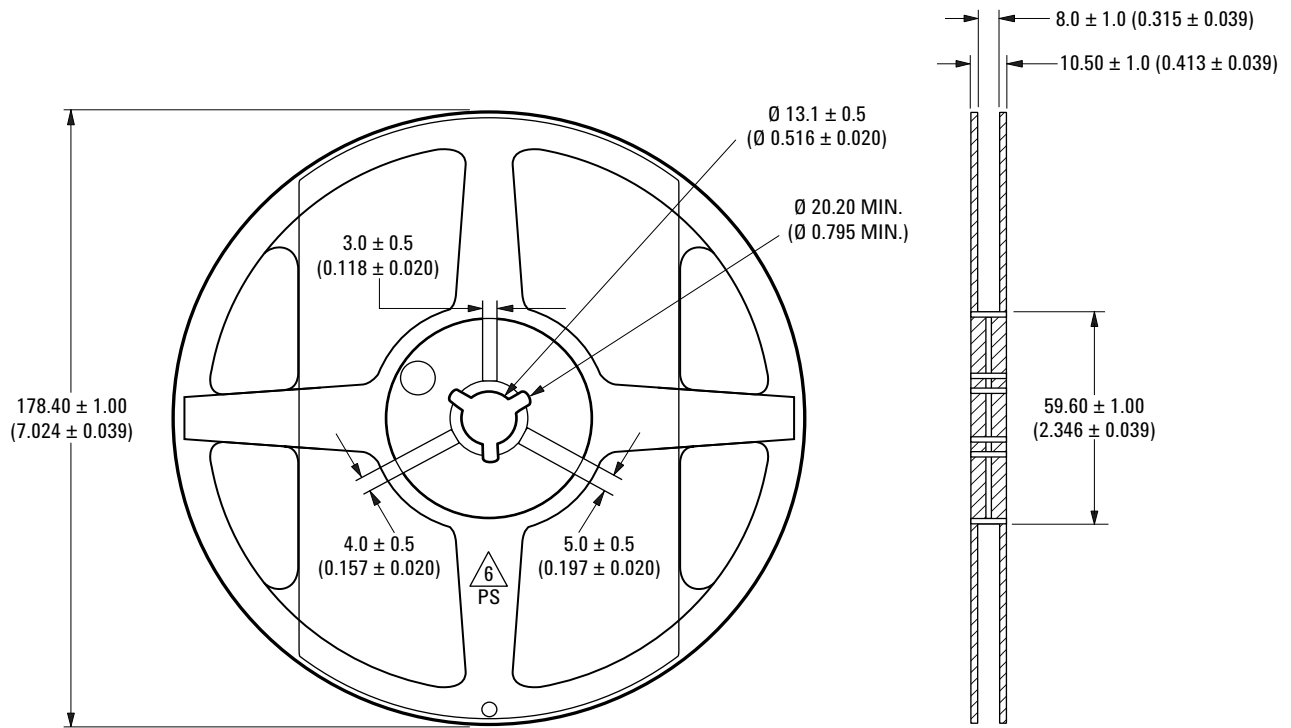

Figure 10. Reel dimensions.

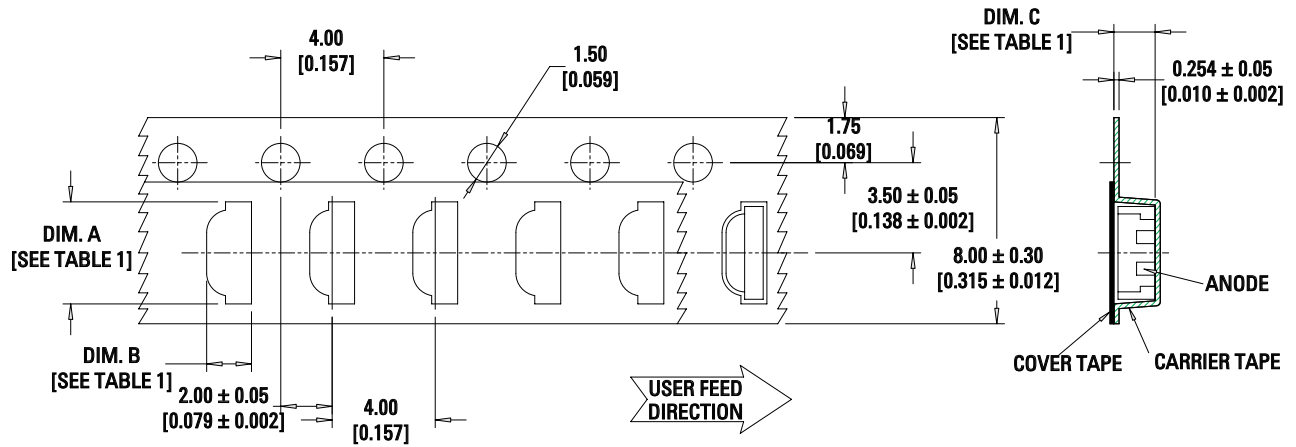

Figure 11. Tape dimensions.

Notes:

1. All dimensions are in millimeters (inches).
2. Tolerance is $\pm 0.1\text{mm}$ ($\pm 0.004\text{in.}$) unless otherwise specified.

PART NUMBER	DIM. A ± 0.10 (0.004)	DIM. B ± 0.10 (0.004)	DIM. C ± 0.10 (0.004)
HSMF-C113	2.75 (0.108)	1.20 (0.047)	1.20 (0.047)
HSMF-C115			

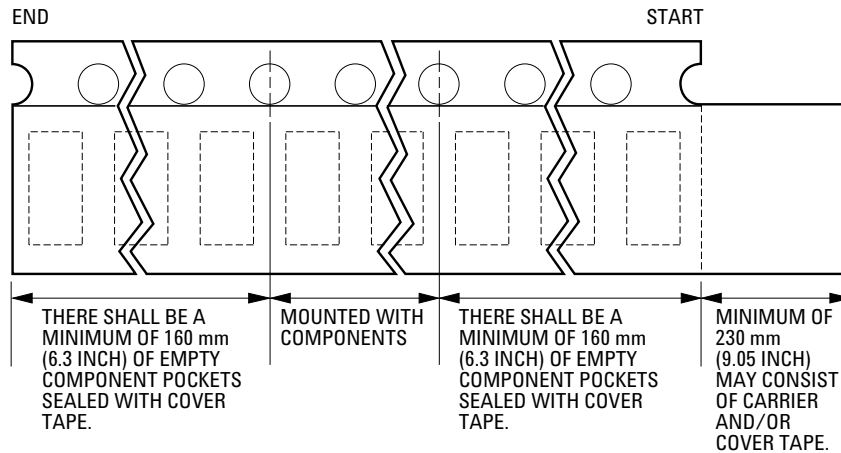

Figure 12. Tape leader and trailer dimensions.

Reflow Soldering:

For more information on reflow soldering, refer to Application Note AN-1060, Surface Mounting SMT LED Indicator Components.

Storage Condition: 5 to 30°C @ 60%RH max.

Baking is required before mounting, if:

1. Humidity Indicator Card is > 10% when read at 23 ± 5°C.
2. Device expose to factory conditions <30°C/60%RH more than 672 hours.

Recommended baking condition: 60±5°C for 20 hours.

For product information and a complete list of distributors, please go to our web site: www.avagotech.com

Avago, Avago Technologies, and the A logo are trademarks of Avago Technologies in the United States and other countries. Data subject to change. Copyright © 2005-2010 Avago Technologies. All rights reserved. Obsoletes 5989-4813EN AV02-0611EN - April 9, 2010

Avago
TECHNOLOGIES