

KEELOQ[®] Code Hopping Decoder

FEATURES

Security

- Secure storage of Manufacturer's Code
- Secure storage of transmitter's keys
- Up to four transmitters can be learned
- KEELOQ[®] code hopping technology
- Normal and secure learning mechanisms

Operating

- 4.0V – 6.0V operation
- 4 MHz external RC oscillator
- Learning indication on LRNOUT
- Auto baud rate detection
- Power saving SLEEP mode

Other

- Stand-alone decoder
- On-chip EEPROM for transmitter storage
- Four binary function outputs—15 functions
- 18-pin DIP/SOIC package

Typical Applications

- Automotive remote entry systems
- Automotive alarm systems
- Automotive immobilizers
- Gate and garage openers
- Electronic door locks
- Identity tokens
- Burglar alarm systems

Compatible Encoders

All KEELOQ encoders and transponders configured for the following setting:

- PWM modulation format (1/3-2/3)
- TE in the range from 100 μ s to 400 μ s
- 10 x TE Header
- 28-bit Serial Number
- 16-bit Synchronization counter
- Discrimination bits equal to Serial Number 8 LSbs
- 66- to 69-bit length code word.

DESCRIPTION

The Microchip Technology Inc. HCS512 is a code hopping decoder designed for secure Remote Keyless Entry (RKE) systems. The HCS512 utilizes the patented KEELOQ code hopping system and high security learning mechanisms to make this a canned solution when used with the HCS encoders to implement a uni-directional remote keyless entry system.

PACKAGE TYPE

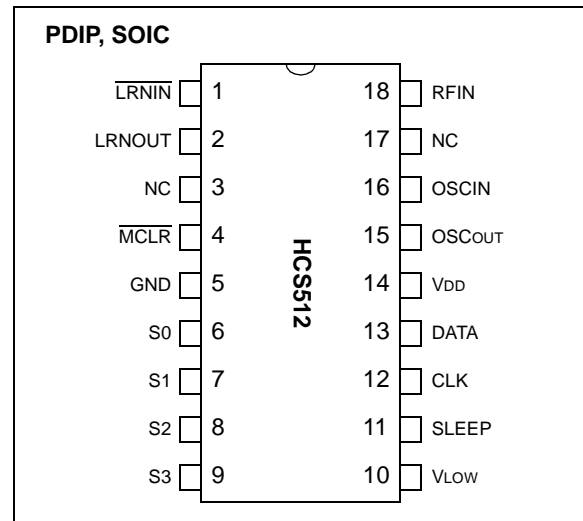

BLOCK DIAGRAM

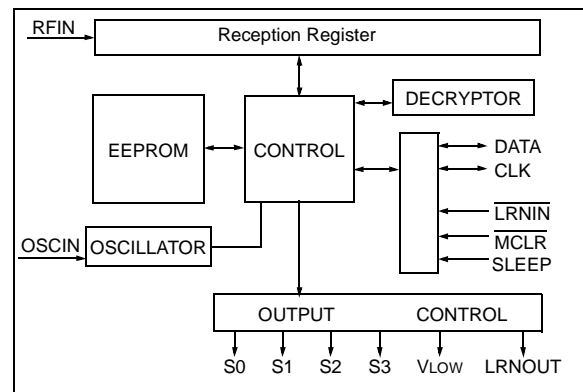

The Manufacturer's Code, transmitter keys, and synchronization information are stored in protected on-chip EEPROM. The HCS512 uses the DATA and CLK inputs to load the Manufacturer's Code which cannot be read out of the device.

HCS512

The HCS512 operates over a wide voltage range of 3.0 volts to 6.0 volts. The decoder employs automatic baud rate detection which allows it to compensate for wide variations in transmitter data rate. The decoder contains sophisticated error checking algorithms to ensure only valid codes are accepted.

1.0 SYSTEM OVERVIEW

Key Terms

The following is a list of key terms used throughout this data sheet. For additional information on KEELOQ and Code Hopping, refer to Technical Brief 3 (TB003).

- **RKE** - Remote Keyless Entry
- **Button Status** - Indicates what button input(s) activated the transmission. Encompasses the 4 button status bits S3, S2, S1 and S0 (Figure 8-2).
- **Code Hopping** - A method by which a code, viewed externally to the system, appears to change unpredictably each time it is transmitted.
- **Code word** - A block of data that is repeatedly transmitted upon button activation (Figure 8-1).
- **Transmission** - A data stream consisting of repeating code words (Figure 8-1).
- **Crypt key** - A unique and secret 64-bit number used to encrypt and decrypt data. In a symmetrical block cipher such as the KEELOQ algorithm, the encryption and decryption keys are equal and will therefore be referred to generally as the crypt key.
- **Encoder** - A device that generates and encodes data.
- **Encryption Algorithm** - A recipe whereby data is scrambled using a crypt key. The data can only be interpreted by the respective decryption algorithm using the same crypt key.
- **Decoder** - A device that decodes data received from an encoder.
- **Decryption algorithm** - A recipe whereby data scrambled by an encryption algorithm can be unscrambled using the same crypt key.
- **Learn** – Learning involves the receiver calculating the transmitter's appropriate crypt key, decrypting the received hopping code and storing the serial number, synchronization counter value and crypt key in EEPROM. The KEELOQ product family facilitates several learning strategies to be implemented on the decoder. The following are examples of what can be done.
 - **Simple Learning**
The receiver uses a fixed crypt key, common to all components of all systems by the same manufacturer, to decrypt the received code word's encrypted portion.
 - **Normal Learning**
The receiver uses information transmitted

during normal operation to derive the crypt key and decrypt the received code word's encrypted portion.

- **Secure Learn**
The transmitter is activated through a special button combination to transmit a stored 60-bit seed value used to generate the transmitter's crypt key. The receiver uses this seed value to derive the same crypt key and decrypt the received code word's encrypted portion.
- **Manufacturer's code** – A unique and secret 64-bit number used to generate unique encoder crypt keys. Each encoder is programmed with a crypt key that is a function of the manufacturer's code. Each decoder is programmed with the manufacturer code itself.

1.1 HCS Encoder Overview

The HCS encoders have a small EEPROM array which must be loaded with several parameters before use. The most important of these values are:

- A crypt key that is generated at the time of production
- A 16-bit synchronization counter value
- A 28-bit serial number which is meant to be unique for every encoder

The manufacturer programs the serial number for each encoder at the time of production, while the 'Key Generation Algorithm' generates the crypt key (Figure 1-1). Inputs to the key generation algorithm typically consist of the encoder's serial number and a 64-bit manufacturer's code, which the manufacturer creates.

Note: The manufacturer code is a pivotal part of the system's overall security. Consequently, all possible precautions must be taken and maintained for this code.

FIGURE 1-1: CREATION AND STORAGE OF CRYPT KEY DURING PRODUCTION

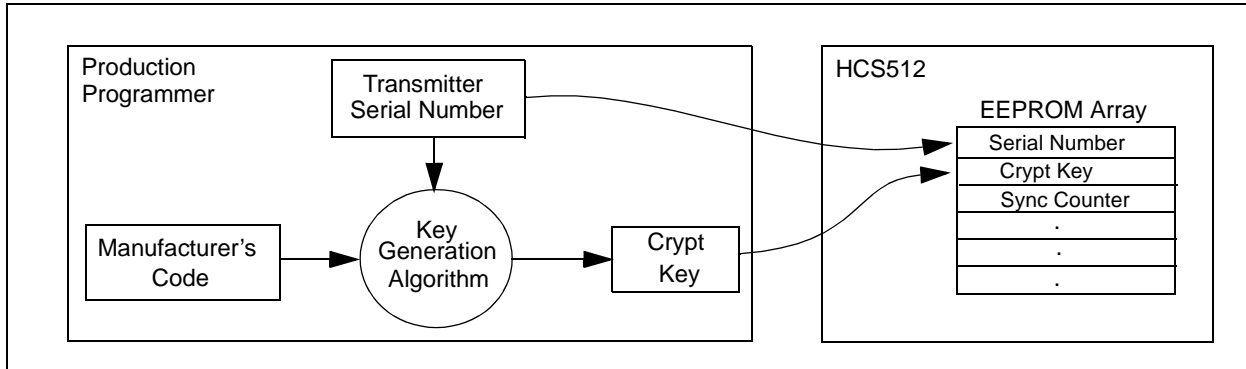

The 16-bit synchronization counter is the basis behind the transmitted code word changing for each transmission; it increments each time a button is pressed. Due to the code hopping algorithm's complexity, each increment of the synchronization value results in greater than 50% of the bits changing in the transmitted code word.

Figure 1-2 shows how the key values in EEPROM are used in the encoder. Once the encoder detects a button press, it reads the button inputs and updates the synchronization counter. The synchronization counter and crypt key are input to the encryption algorithm and the output is 32 bits of encrypted information. This data will change with every button press, its value appearing externally to 'randomly hop around', hence it is referred to as the hopping portion of the code word. The 32-bit hopping code is combined with the button information and serial number to form the code word transmitted to the receiver. The code word format is explained in greater detail in Section 8.2.

A receiver may use any type of controller as a decoder, but it is typically a microcontroller with compatible firmware that allows the decoder to operate in conjunction with an HCS512 based transmitter. Section 5.0 provides detail on integrating the HCS512 into a system.

A transmitter must first be 'learned' by the receiver before its use is allowed in the system. Learning includes calculating the transmitter's appropriate crypt key, decrypting the received hopping code and storing the serial number, synchronization counter value and crypt key in EEPROM.

In normal operation, each received message of valid format is evaluated. The serial number is used to determine if it is from a learned transmitter. If from a learned transmitter, the message is decrypted and the synchronization counter is verified. Finally, the button status is checked to see what operation is requested. Figure 1-3 shows the relationship between some of the values stored by the receiver and the values received from the transmitter.

FIGURE 1-2: BUILDING THE TRANSMITTED CODE WORD (ENCODER)

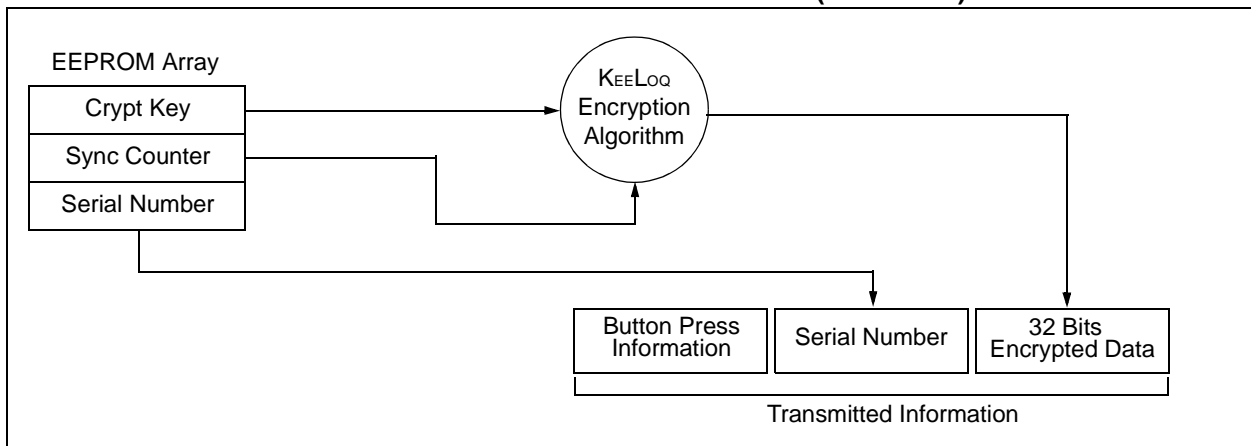
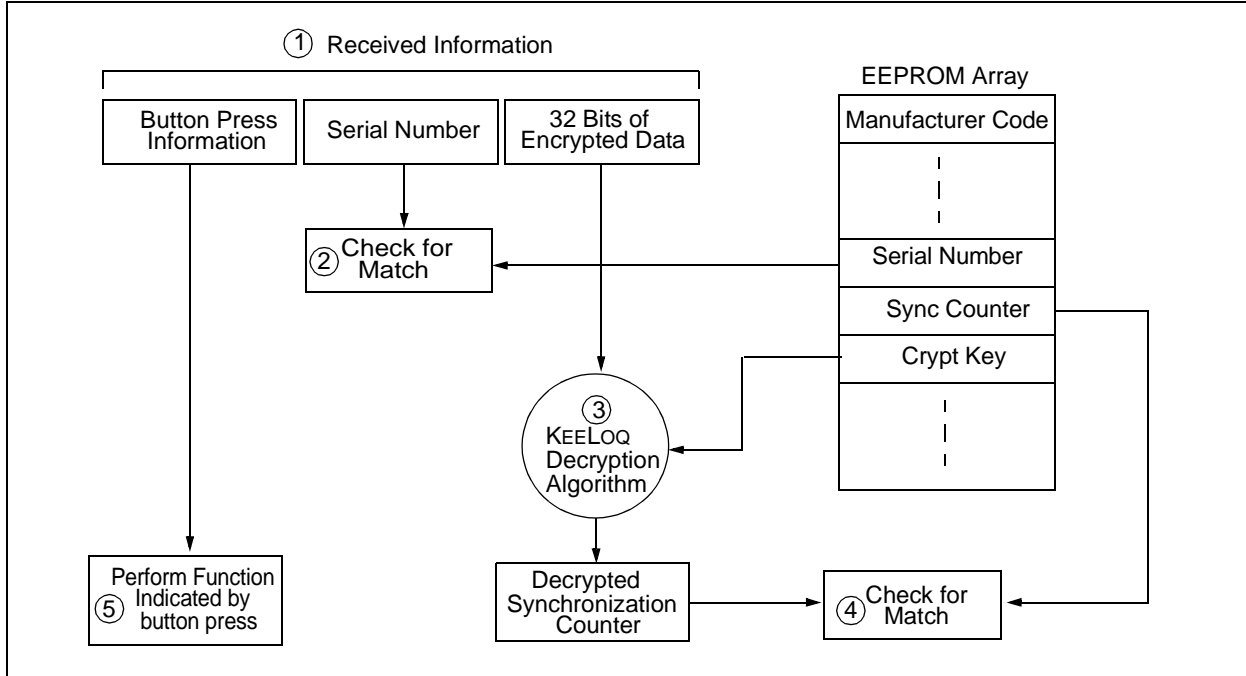

FIGURE 1-3: BASIC OPERATION OF RECEIVER (DECODER)



NOTE: Circled numbers indicate the order of execution.

2.0 PIN ASSIGNMENT

PIN	Decoder Function	I/O ⁽¹⁾	Buffer Type ⁽¹⁾	Description
1	LRNIN	I	TTL	Learn input - initiates learning, 10K pull-up required on input
2	LRNOUT	O	TTL	Learn output - indicates learning
3	NC	—	TTL	Do not connect
4	$\overline{\text{MCLR}}$	I	ST	Master clear input
5	Ground	P	—	Ground connection
6	S0	O	TTL	Switch 0
7	S1	O	TTL	Switch 1
8	S2	O	TTL	Switch 2
9	S3	O	TTL	Switch 3
10	V _{Low}	O	TTL	Battery low indication output
11	SLEEP	I	TTL	Connect to RFIN to allow wake-up from SLEEP
12	CLK	I/O	TTL/ST ⁽²⁾	Clock in Programming mode and Synchronous mode
13	DATA	I/O	TTL/ST ⁽²⁾	Data in Programming mode and Synchronous mode
14	VDD	P	—	Power connection
15	OSCO _{UT} (1MHz)	O	TTL	Oscillator out (test point)
16	OSCI _N (4MHz)	I	ST	Oscillator in – recommended values 4.7 kΩ and 22 pF
17	NC	—	—	
18	RFIN	I	TTL	RF input from receiver

Note 1: P = power, I = in, O = out, and ST = Schmitt Trigger input.

Note 2: Pin 12 and Pin 13 have a dual purpose. After RESET, these pins are used to determine if Programming mode is selected in which case they are the clock and data lines. In normal operation, they are the clock and data lines of the synchronous data output stream.

3.0 DESCRIPTION OF FUNCTIONS

3.1 Parallel Interface

The HCS512 activates the S3, S2, S1 & S0 outputs when a new valid code is received. The outputs will be activated for approximately 500 ms. If a repeated code is received during this time, the output extends for approximately 500 ms.

3.2 Serial Interface

The decoder has a PWM/Synchronous interface connection to microcontrollers with limited I/O. An output data stream is generated when a valid transmission is received. The data stream consists of one START bit, four function bits, one bit for battery status, one bit to indicate a repeated transmission, two status bits, and one STOP bit. (Table 3-1). The DATA and CLK lines are used to send a synchronous event message.

A special status message is transmitted on the second pass of learn. This allows the controlling microcontroller to determine if the learn was successful (Result = 1) and if a previous transmitter was overwritten (Overwrite = 1). The status message is shown in Figure 3-2.

Table 3-1 show the values for TX1:0 and the number of transmitters learned.

TABLE 3-1: STATUS BITS

TX1	TX0	Number of Transmitters
0	0	One
0	1	Two
1	0	Three
1	1	Four

FIGURE 3-1: DATA OUTPUT FORMAT

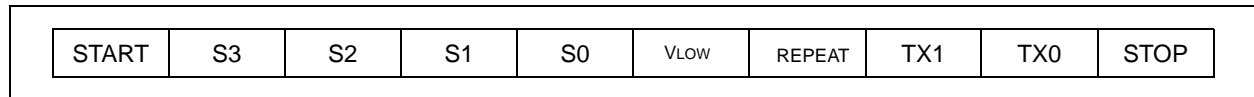
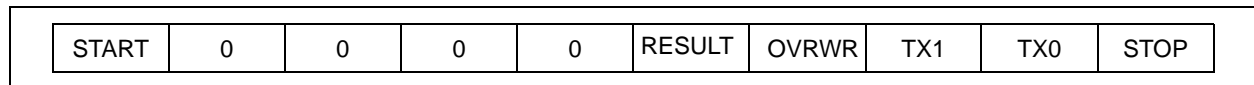

FIGURE 3-2: STATUS MESSAGE FORMAT



A 1-wire PWM or 2-wire synchronous interface can be used.

In 1-wire mode, the data is transmitted as a PWM signal with a basic pulse width of 400 μ s.

In 2-wire mode, Synchronous mode PWM bits start on the rising edge of the clock, and the bits must be sampled on the falling edge. The START bit is a '1' and the STOP bit is '0'.

FIGURE 3-2: PWM OUTPUT FORMAT⁽¹⁾

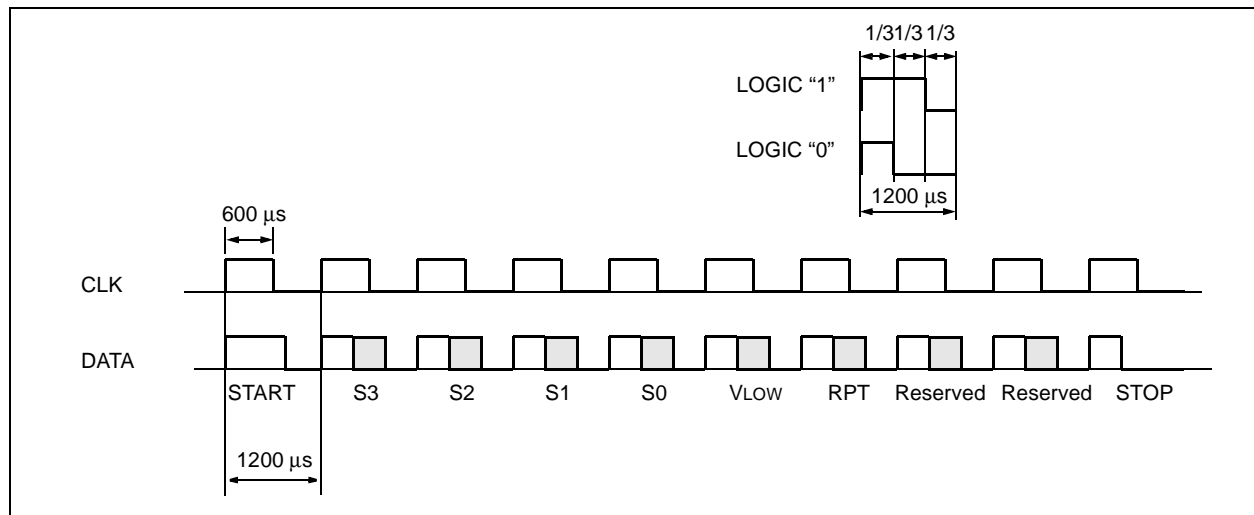

Note: The Decoder output PWM format logic ("1" / "0") is reversed with respect of the Encoder modulation format.

4.0 DECODER OPERATION

4.1 Learning a Transmitter to a Receiver

Either the serial number-based learning method or the seed-based learning method can be selected. The learning method is selected in the configuration byte. In order for a transmitter to be used with a decoder, the transmitter must first be 'learned'. When a transmitter is learned to a decoder, the decoder stores the crypt key, a check value of the serial number and current synchronization value in EEPROM. The decoder must keep track of these values for every transmitter that is learned. The maximum number of transmitters that can be learned is four. The decoder must also contain the Manufacturer's Code in order to learn a transmitter. The Manufacturer's Code will typically be the same for all decoders in a system.

The HCS512 has four memory slots. After an "erase all" procedure, all the memory slots will be cleared. Erase all is activated by taking $\overline{\text{LRNIN}}$ low for approximately 10 seconds. When a new transmitter is learned, the decoder searches for an empty memory slot and stores the transmitter's information in that memory slot. When all memory slots are full, the decoder randomly overwrites existing transmitters.

4.1.1 LEARNING PROCEDURE

Learning is activated by taking the $\overline{\text{LRNIN}}$ input low for longer than 64 ms. This input requires an external pull-up resistor.

To learn a new transmitter to the HCS512 decoder, the following sequence is required:

1. Enter Learning mode by pulling $\overline{\text{LRNIN}}$ low for longer than 64 ms. The LRNOUT output will go high.
2. Activate the transmitter until the LRNOUT output goes low indicating reception of a valid code (hopping message).
3. Activate the transmitter a second time until the LRNOUT toggles for 4 seconds (in Secure Learning mode, the seed transmission must be transmitted during the second stage of learn by activating the appropriate buttons on the transmitter).

If $\overline{\text{LRNIN}}$ is taken low momentarily during the learn status indication, the indication will be terminated. Once a successful learning sequence is detected, the indication can be terminated allowing quick learning in a manufacturing setup.

4. The transmitter is now learned into the decoder.
5. Repeat steps 1-4 to learn up to four transmitters.
6. Learning will be terminated if two non-sequential codes were received or if two acceptable codes were not decoded within 30 seconds.

The following checks are performed on the decoder to determine if the transmission is valid during learn:

- The first code word is checked for bit integrity.
- The second code word is checked for bit integrity.
- The hopping code is decrypted.
- If all the checks pass, the serial number and synchronization counters are stored in EEPROM memory.

Figure 4-1 shows a flow chart of the learn sequence.

FIGURE 4-1: LEARN SEQUENCE

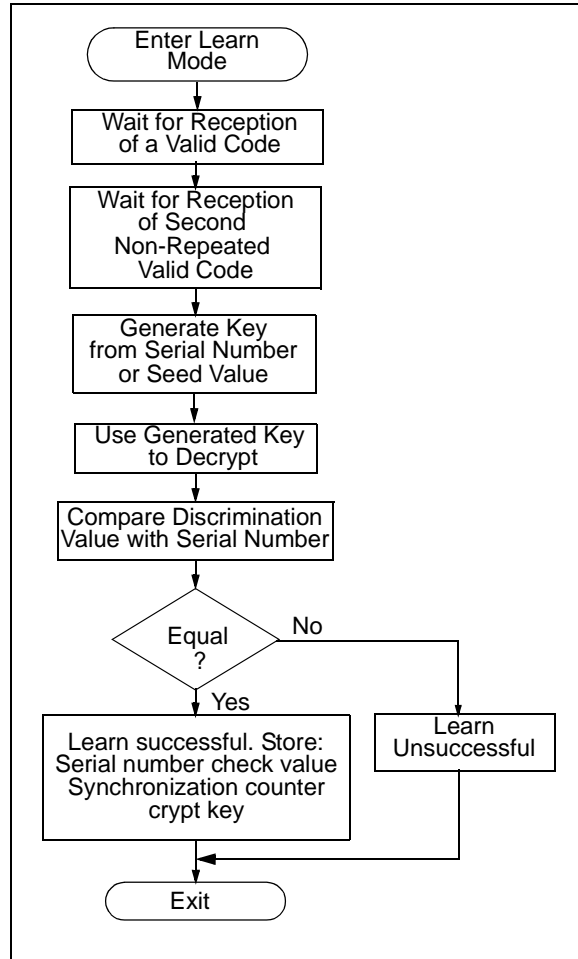

4.2 Validation of Codes

The decoder waits for a transmission and checks the serial number to determine if the transmitter has been learned. If learned, the decoder decrypts the encrypted portion of the transmission using the crypt key. It uses the discrimination bits to determine if the decryption was valid. If everything up to this point is valid, the synchronization value is evaluated.

4.3 Validation Steps

Validation consists of the following steps:

- Search EEPROM to find the Serial Number Check Value Match
- Decrypt the Hopping Code
- Compare the 10 bits of discrimination value with the lower 10 bits of serial number
- Check if the synchronization counter falls within the first synchronization window.
- Check if the synchronization counter falls within the second synchronization window.
- If a valid transmission is found, update the synchronization counter, else use the next transmitter block and repeat the tests.

FIGURE 4-2: DECODER OPERATION

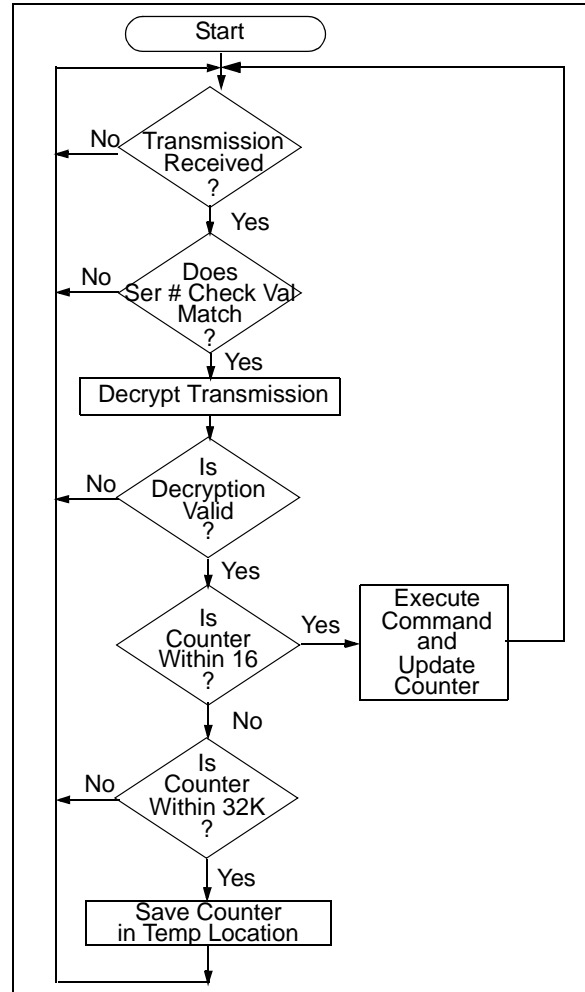

4.4 Synchronization with Decoder (Evaluating the Counter)

The KEELOQ technology patent scope includes a sophisticated synchronization technique that does not require the calculation and storage of future codes. The technique securely blocks invalid transmissions while providing transparent resynchronization to transmitters inadvertently activated away from the receiver.

Figure 4-3 shows a 3-partition, rotating synchronization window. The size of each window is optional but the technique is fundamental. Each time a transmission is authenticated, the intended function is executed and the transmission's synchronization counter value is stored in EEPROM. From the currently stored counter value there is an initial "Single Operation" forward window of 16 codes. If the difference between a received synchronization counter and the last stored counter is within 16, the intended function will be executed on the single button press and the new synchronization counter will be stored. Storing the new synchronization counter value effectively rotates the entire synchronization window.

A "Double Operation" (resynchronization) window further exists from the Single Operation window up to 32K codes forward of the currently stored counter value. It

is referred to as "Double Operation" because a transmission with synchronization counter value in this window will require an additional, sequential counter transmission prior to executing the intended function. Upon receiving the sequential transmission the decoder executes the intended function and stores the synchronization counter value. This resynchronization occurs transparently to the user as it is human nature to press the button a second time if the first was unsuccessful.

The third window is a "Blocked Window" ranging from the double operation window to the currently stored synchronization counter value. Any transmission with synchronization counter value within this window will be ignored. This window excludes previously used, perhaps code-grabbed transmissions from accessing the system.

Note: The synchronization method described in this section is only a typical implementation and because it is usually implemented in firmware, it can be altered to fit the needs of a particular system.

FIGURE 4-3: SYNCHRONIZATION WINDOW

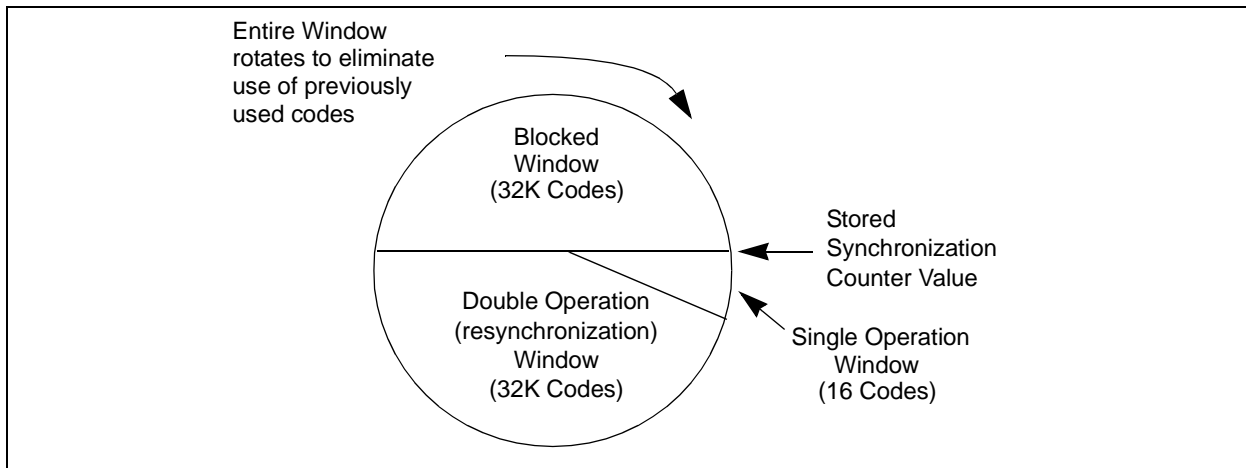

4.5 SLEEP Mode

The SLEEP mode of the HCS512 is used to reduce current consumption when no RF input signal is present. SLEEP mode will only be effective in systems where the RF receiver is relatively quiet when no signal is present. During SLEEP, the clock stops, thereby significantly reducing the operating current. SLEEP mode is enabled by the SLEEP bit in the configuration byte.

The HCS512 will enter SLEEP mode when:

- The RF line is low
- After a function output is switched off
- Learn mode is terminated (time-out reached)

The device will not enter SLEEP mode when:

- A function output is active
- Learn sequence active
- Device is in Programming mode

The device will wake-up from SLEEP when:

- The SLEEP input pin changes state
- The CLOCK line changes state

Note: During SLEEP mode the CLK line will change from an output line to an input line that can be used to wake-up the device. Connect CLK to $\overline{\text{LRNIN}}$ via a 100K resistor to reliably enter the Learn mode whenever SLEEP mode is active.

5.0 INTEGRATING THE HCS512 INTO A SYSTEM

The HCS512 can act as a stand-alone decoder or be interfaced to a microcontroller. Typical stand-alone applications include garage door openers and electronic door locks. In stand-alone applications, the HCS512 will handle learning, reception, decryption, and validation of the received code; and generate the appropriate output. For a garage door opener, the HCS512 input will be connected to an RF receiver, and the output, to a relay driver to connect a motor controller.

Typical systems where the HCS512 will be connected to a microcontroller include vehicle and home security systems. The HCS512 input will be connected to an RF receiver and the function outputs to the microcontroller. The HCS512 will handle all the decoding functions and the microcontroller, all the system functions. The Serial Output mode with a 1- or 2-wire interface can be used if the microcontroller is I/O limited.

6.0 DECODER PROGRAMMING

The PG306001 production programmer will allow easy setup and programming of the configuration byte and the manufacturer's code.

6.1 Configuration Byte

The configuration byte is used to set system configuration for the decoder. The LRN bits determine which algorithm (Decrypt or XOR) is used for the key generation. SC_LRN determines whether normal learn (key derived from serial number) or secure learn (key derived from seed value) is used.

TABLE 6-1: CONFIGURATION BYTE

Bit	Name	Description
0	LRN0	Learn algorithm select
1	LRN1	Not used
2	SC_LRN	Secure Learn enable (1 = enabled)
3	SLEEP	SLEEP enable (1 = enabled)
4	RES1	Not used
5	RES2	Not used
6	RES3	Not used
7	RES4	Not used

TABLE 6-2: LEARN METHOD LRN0, LRN1 DEFINITIONS

LRN0	Description
0	Decrypt algorithm
1	XOR algorithm

6.2 Programming the Manufacturer's Code

The manufacturer's code must be programmed into EEPROM memory through the synchronous programming interface using the DATA and CLK lines. Provision must be made for connections to these pins if the decoder is going to be programmed in circuit.

Programming mode is activated if the CLK is low for at least 1 ms and then goes high within 64 ms after power-up, stays high for longer than 8 ms but not longer than 128 ms. After entering Programming mode the 64-bit manufacturer's code, 8-bit configuration byte, and 8-bit checksum is sent to the device using the synchronous interface. After receiving the 80-bit message the checksum is verified and the information is written to EEPROM. If the programming operation was successful, the HCS512 will respond with an Acknowledge pulse.

After programming the manufacturer's code, the HCS512 decoder will automatically activate an Erase All function, removing all transmitters from the system.

6.3 Download Format

The manufacturer's code and configuration byte must be downloaded Least Significant Byte, Least Significant bit first as shown in Table 6-3.

6.4 Checksum

The checksum is used by the HCS512 to check that the data downloaded was correctly received before programming the data. The checksum is calculated so that the 10 bytes added together (discarding the overflow bits) is zero. The checksum can be calculated by adding the first 9 bytes of data together and subtracting the result from zero. Throughout the calculation the overflow is discarded.

Given a manufacturer's code of 01234567-89ABCDEF₁₆ and a Configuration Word of 1₁₆, the checksum is calculated as shown in Figure 6-1. The checksum is 3F₁₆.

6.5 Test Transmitter

The HCS512 decoder will automatically add a test transmitter each time an Erase All Function is done. A test transmitter is defined as a transmitter with a serial number of zero. After an Erase All, the test transmitter will always work without learning and will not check the synchronization counter of the transmitter. Learning of any new transmitters will erase the test transmitter.

Note 1: A transmitter with a serial number of zero cannot be learned. Learn will fail after the first transmission.

2: Always learn at least one transmitter after an Erase All sequence. This ensures that the test transmitter is erased.

TABLE 6-3: DOWNLOAD DATA

Byte 9	Byte 8	Byte 7	Byte 6	Byte 5	Byte 4	Byte 3	Byte 2	Byte 1	Byte 0
Check-sum	Config	Man Key_7	Man Key_6	Man Key_5	Man Key_4	Man Key_3	Man Key_2	Man Key_1	Man Key_0

Byte 0, right-most bit downloaded first. →

FIGURE 6-1: CHECKSUM CALCULATION

$$\begin{aligned}
 01_{16} + 23_{16} &= 24_6 \\
 24_{16} + 45_{16} &= 69_{16} \\
 69_{16} + 67_{16} &= D0_{16} \\
 D0_{16} + 89_{16} &= 159_{16} \\
 59_{16} + AB_{16} &= 104_{16} \text{ (Carry is discarded)} \\
 04_{16} + CD_{16} &= D1_{16} \text{ (Carry is discarded)} \\
 D1_{16} + EF_{16} &= 1C0_{16} \\
 C0_{16} + 1_{16} &= C1_{16} \text{ (Carry is discarded)} \\
 (FF_{16} - C1_{16}) + 1_{16} &= 3F_{16}
 \end{aligned}$$

FIGURE 6-2: PROGRAMMING WAVEFORMS

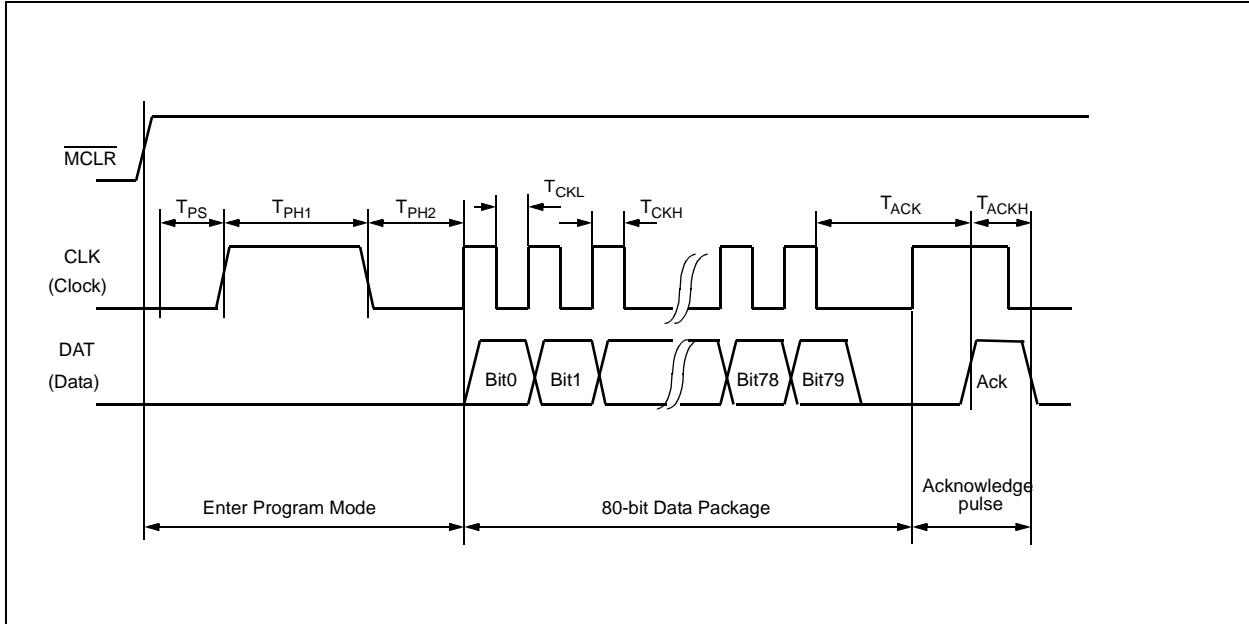

TABLE 6-4: PROGRAMMING TIMING REQUIREMENTS

Parameter	Symbol	Min.	Max.	Units
Program mode setup time	TPS	1	64	ms
Hold time 1	TPH1	8	128	ms
Hold time 2	TPH2	0.05	320	ms
Clock High Time	TCKH	0.05	320	ms
Clock Low Time	TCKL	0.050	320	ms
Acknowledge Time	TACK	—	80	ms
Acknowledge duration	TACKH	1	—	ms

Note: F_{osc} equals 4 MHz.

HCS512

7.0 KEY GENERATION SCHEMES

The HCS512 decoder has two key generation schemes. Normal learning uses the transmitter's serial number to derive two input seeds which are used as inputs to the key generation algorithm. Secure learning uses the seed transmission to derive the two input seeds. Two key generation algorithms are available to convert the inputs seeds to secret keys. The appropriate scheme is selected in the Configuration Word.

FIGURE 7-1:

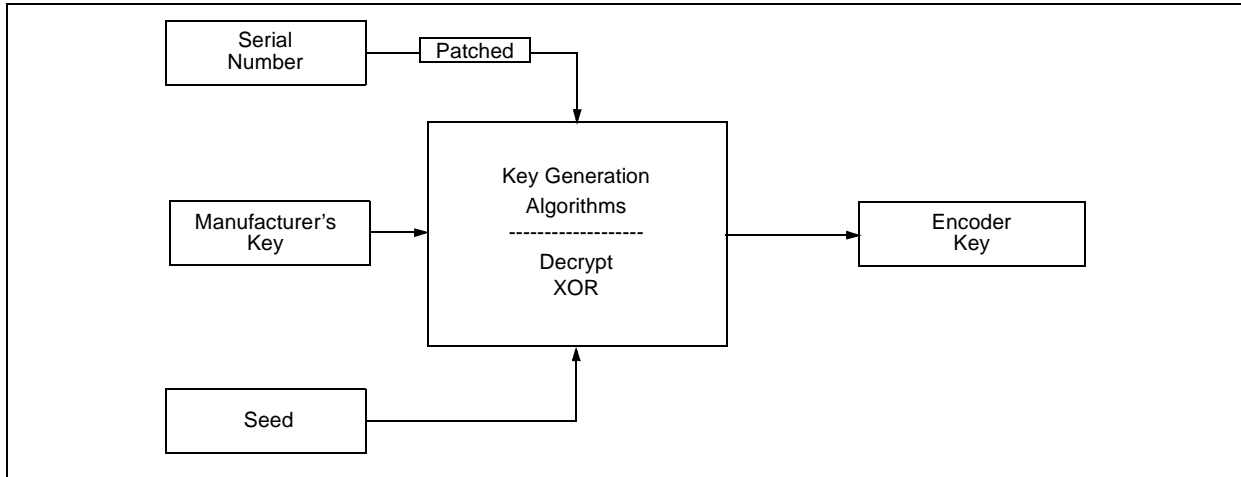

7.1 Normal Learning (Serial Number Derived)

The two input seeds are composed from the serial number in two ways, depending on the encoder type. The encoder type is determined from the number of bits in the incoming transmission. SourceH is used to calculate the upper 32 bits of the crypt key, and SourceL, for the lower 32 bits.

For 28-bit serial number encoders (66 / 67-bit transmissions):

SourceH = 6H + 28 bit Serial Number
SourceL = 2H + 28 bit Serial Number

7.2 Secure Learning (Seed Derived)

The two input seeds are composed from the seed value that is transmitted during secure learning. The lower 32 bits of the seed transmission is used to compose the lower seed, and the upper 32 bits, for the upper seed. The upper 4 bits (function code) are set to zero.

For 32-bit seed encoders:

SourceH = Serial Number_{Lower 28 bits} (with upper 4 bits always zero)
SourceL = Seed_{32 bits}

For 48-bit seed encoders:

SourceH = Seed_{Upper 16 bits} + Serial Number_{Upper 16 bits} (with upper 4 bits always zero) << 16
SourceL = Seed_{Lower 32 bits}

For 60-bit seed encoders:

SourceH = Seed_{Upper 28 bits} (with upper 4 bits always zero)
SourceL = Seed_{Lower 32 bits}

7.3 Key Generation Algorithms

There are two key generation algorithms implemented in the HCS512 decoder. The `KEELOQ` decryption algorithm provides a higher level of security than the XOR algorithm. Section 6.1 describes the selection of the algorithms in the configuration byte.

7.3.1 KEELOQ DECRYPT ALGORITHM

This algorithm uses the `KEELOQ` decryption algorithm and the manufacturer's code to derive the crypt key as follows:

Key_{Upper 32 bits} = Decrypt (SourceH) 64 Bit Manufacturers Code

Key_{Lower 32 bits} = Decrypt (SourceL) 64 Bit Manufacturers Code

7.3.2 XOR WITH THE MANUFACTURER'S CODE

The two 32-bits seeds are XOR with the manufacturer's code to form the 64 bit crypt key.

Key_{Upper 32 bits} = SourceH XOR Manufacturers Code_{Upper 32 bits}

Key_{Lower 32 bits} = SourceL XOR Manufacturers Code_{Lower 32 bits}

After programming the manufacturer's code, the HCS512 decoder will automatically activate an Erase All function, removing all transmitters from the system.

If `LRNIN` is taken low momentarily during the learn status indication, the indication will be terminated. Once a successful learning sequence is detected, the indication can be terminated, allowing quick learning in a manufacturing setup.

FIGURE 7-2: HCS512 KEY GENERATION

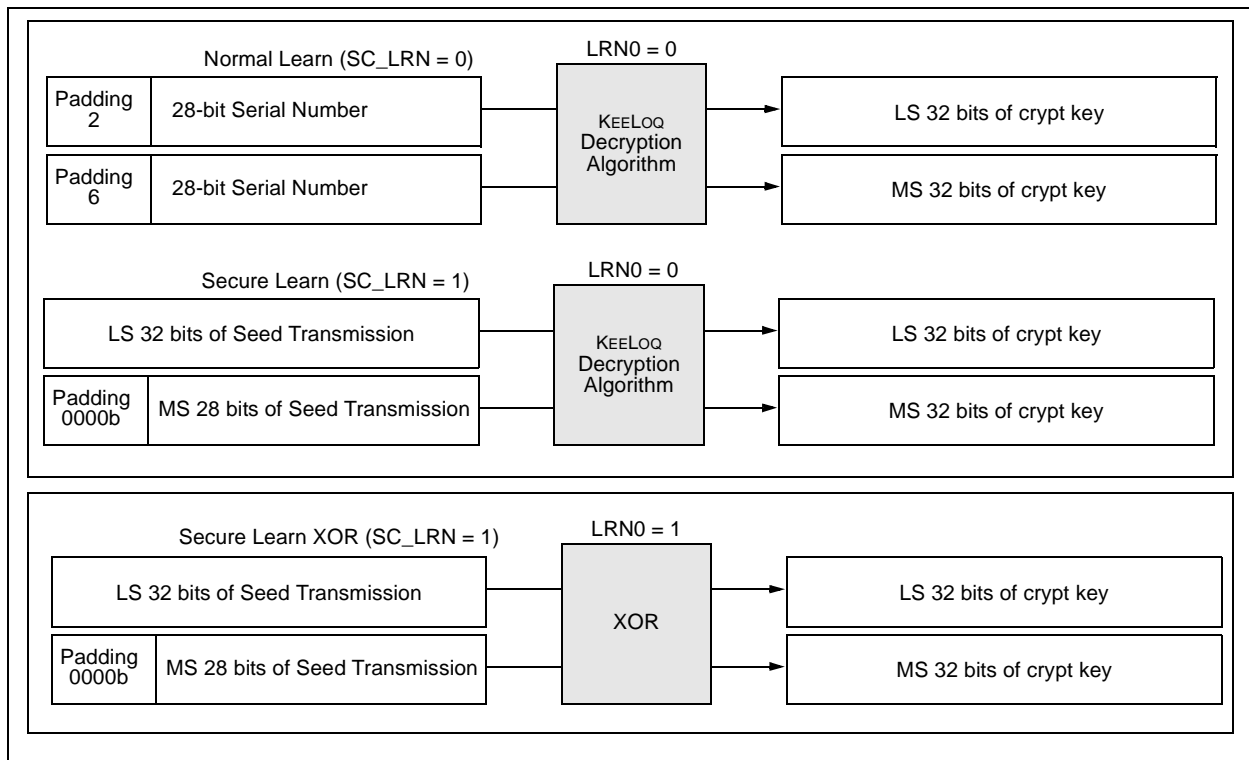

HCS512

8.0 KEELOQ ENCODERS

8.1 Transmission Format (PWM)

The KEELOQ encoder transmission is made up of several parts (Figure 8-1). Each transmission begins with a preamble and a header, followed by the encrypted and then the fixed data. The actual data is 66/69 bits which consists of 32 bits of encrypted data and 34/37 bits of non-encrypted data. Each transmission is followed by a guard period before another transmission can begin. The encrypted portion provides up to four billion changing code combinations and includes the button status bits (based on which buttons were activated) along with the synchronization counter value and some discrimination bits. The non-encrypted portion is comprised of the status bits, the function bits,

and the 28-bit serial number. The encrypted and non-encrypted combined sections increase the number of combinations to 7.38×10^{19} .

8.2 Code Word Organization

The HCSXXX encoder transmits a 66/69-bit code word when a button is pressed. The 66/69-bit word is constructed from an encryption portion and a non-encrypted code portion (Figure 8-2).

The **Encrypted Data** is generated from four button bits, two overflow counter bits, ten discrimination bits, and the 16-bit synchronization value.

The **Non-encrypted Data** is made up from 2 status bits, 4 function bits, and the 28/32-bit serial number.

FIGURE 8-1: TRANSMISSION FORMAT (PWM)

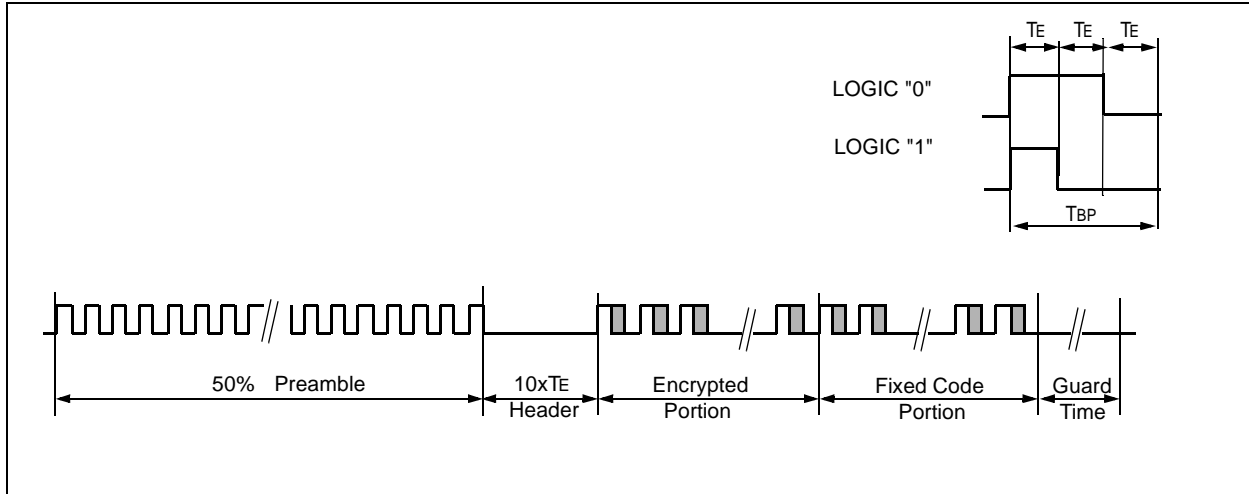
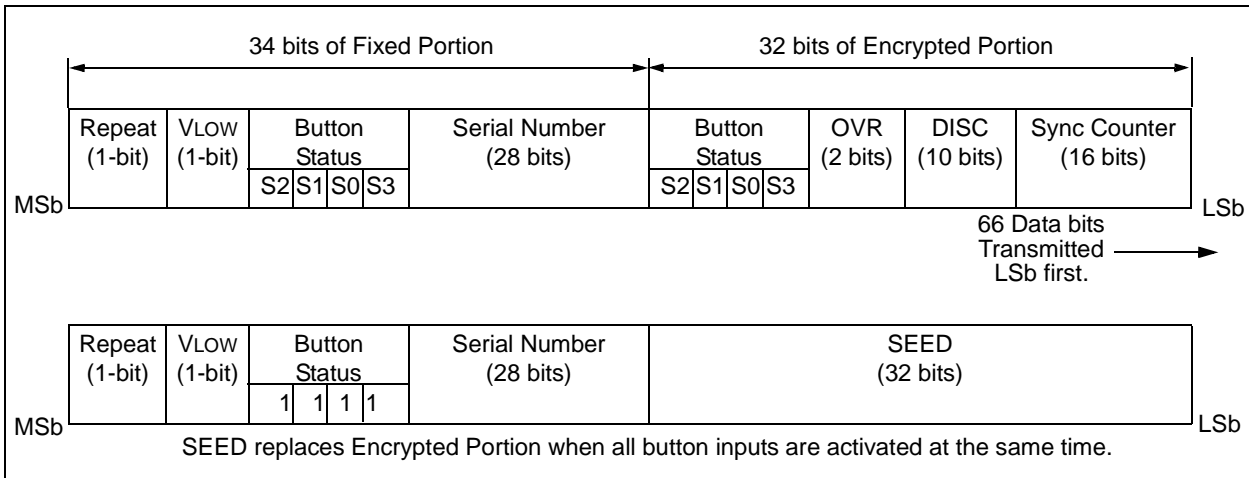

FIGURE 8-2: CODE WORD ORGANIZATION



9.0 ELECTRICAL CHARACTERISTICS FOR HCS512

Absolute Maximum Ratings †

Ambient temperature under bias.....	-55°C to +125°C
Storage temperature	-65°C to +150°C
Voltage on any pin with respect to V_{SS} (except V_{DD})	-0.6V to V_{DD} +0.6V
Voltage on V_{DD} with respect to V_{SS}	0 to +7.5V
Total power dissipation (Note 1)	800 mW
Maximum current out of V_{SS} pin.....	150 mA
Maximum current into V_{DD} pin.....	100 mA
Input clamp current, I_{IK} ($V_I < 0$ or $V_I > V_{DD}$).....	± 20 mA
Output clamp current, I_{OK} ($V_O < 0$ or $V_O > V_{DD}$)	± 20 mA
Maximum output current sunk by any I/O pin.....	25 mA
Maximum output current sourced by any I/O pin	20 mA

Note: Power dissipation is calculated as follows: $P_{dis} = V_{DD} \times \{I_{DD} - \sum I_{OH}\} + \sum \{(V_{DD} - V_{OH}) \times I_{OH}\} + \sum (V_{OL} \times I_{OL})$

† NOTICE: Stresses above those listed under “Absolute Maximum Ratings” may cause permanent damage to the device. This is a stress rating only and functional operation of the device at those or any other conditions above those indicated in the operation listings of this specification is not implied. Exposure to maximum rating conditions for extended periods may affect device reliability.

HCS512

TABLE 9-1: DC CHARACTERISTICS

		Standard Operating Conditions (unless otherwise stated)				
		Operating temperature				
		Commercial (C): 0°C ≤ TA ≤ +70°C for commercial				
		Industrial (I): -40°C ≤ TA ≤ +85°C for industrial				
Symbol	Characteristic	Min	Typ ^(†)	Max	Units	Conditions
VDD	Supply Voltage	4.0	—	6.0	V	
VPOR	VDD start voltage to ensure RESET	—	VSS	—	V	
SVDD	VDD rise rate to ensure RESET	0.05*	—	—	V/ms	
IDD	Supply Current	—	1.8	4.5	mA	FOSC = 4 MHz, VDD = 5.5V (During EEPROM programming) In SLEEP mode
		—	7.3	10	mA	
		—	15	32	μA	
VIL	Input Low Voltage	VSS	—	0.16 VDD	V	except $\overline{\text{MCLR}} = 0.2 \text{ VDD}$
VIH	Input High Voltage	0.48 VDD	—	VDD	V	except $\overline{\text{MCLR}} = 0.85 \text{ VDD}$
VOL	Output Low Voltage	—	—	0.6	V	IOL = 8.5 mA, VDD = 4.5V
VOH	Output High Voltage	VDD-0.7	—	—	V	IOH = -3.0 mA, VDD = 4.5V

† Data in "Typ" column is at 5.0V, 25°C unless otherwise stated. These parameters are for design guidance only and are not tested.

* These parameters are characterized but not tested.

Note: Negative current is defined as coming out of the pin.

TABLE 9-2: AC CHARACTERISTICS

Symbol	Characteristic	Min	Typ	Max	Units	Conditions
FOSC	Oscillator frequency	2.7	4	6.21	MHz	REXT = 10K, CEXT = 10 pF
TE	PWM elemental pulse width	65	—	1080	μs	4.5V < VDD < 5.5V Oscillator components tolerance < 6%.
		130	—	1080	μs	3V < VDD < 6V Oscillator components tolerance < 10%
TOD	Output delay	70	90	115	ms	
TA	Output activation time	322	500	740	ms	
TRPT	REPEAT activation time	32	50	74	ms	
TLRN	$\overline{\text{LRNIN}}$ activation time	21	32	—	ms	
TMCLR	$\overline{\text{MCLR}}$ low time	150	—	—	ns	
TOV	Time output valid	—	150	222	ms	

* These parameters are characterized but not tested.

FIGURE 9-1: RESET WATCHDOG TIMER, OSCILLATOR START-UP TIMER AND POWER-UP TIMER TIMING

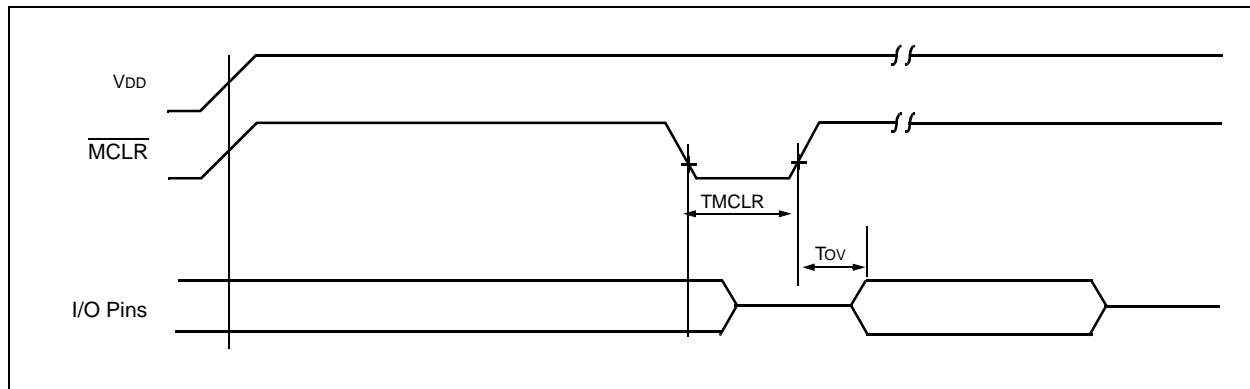
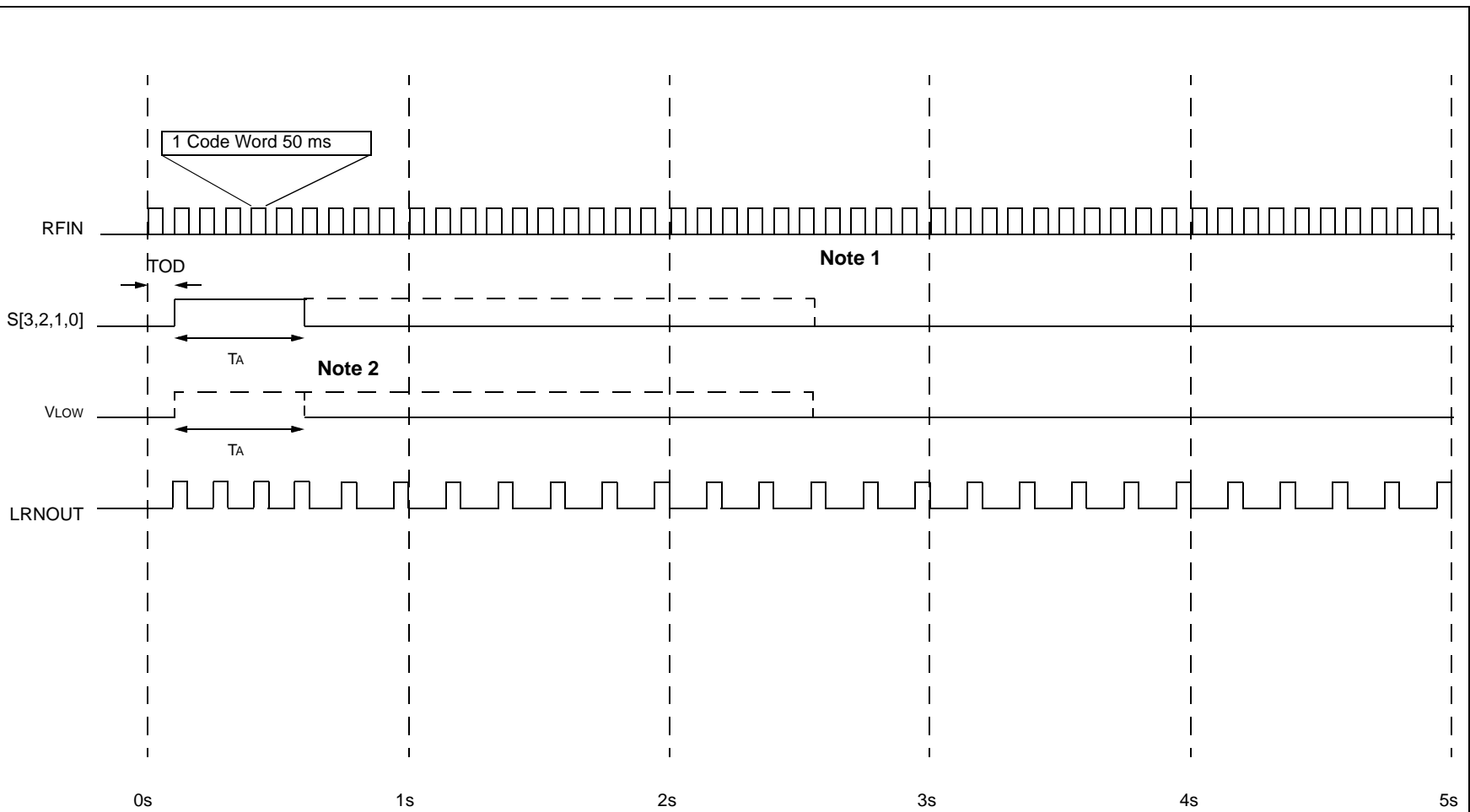

FIGURE 9-2: OUTPUT ACTIVATION



Note 1: Output is activated as long as code is received.

Note 2: Output is activated if battery low (V_{Low}) is detected.

HCS512

FIGURE 9-3: TYPICAL DECODER APPLICATION CIRCUIT

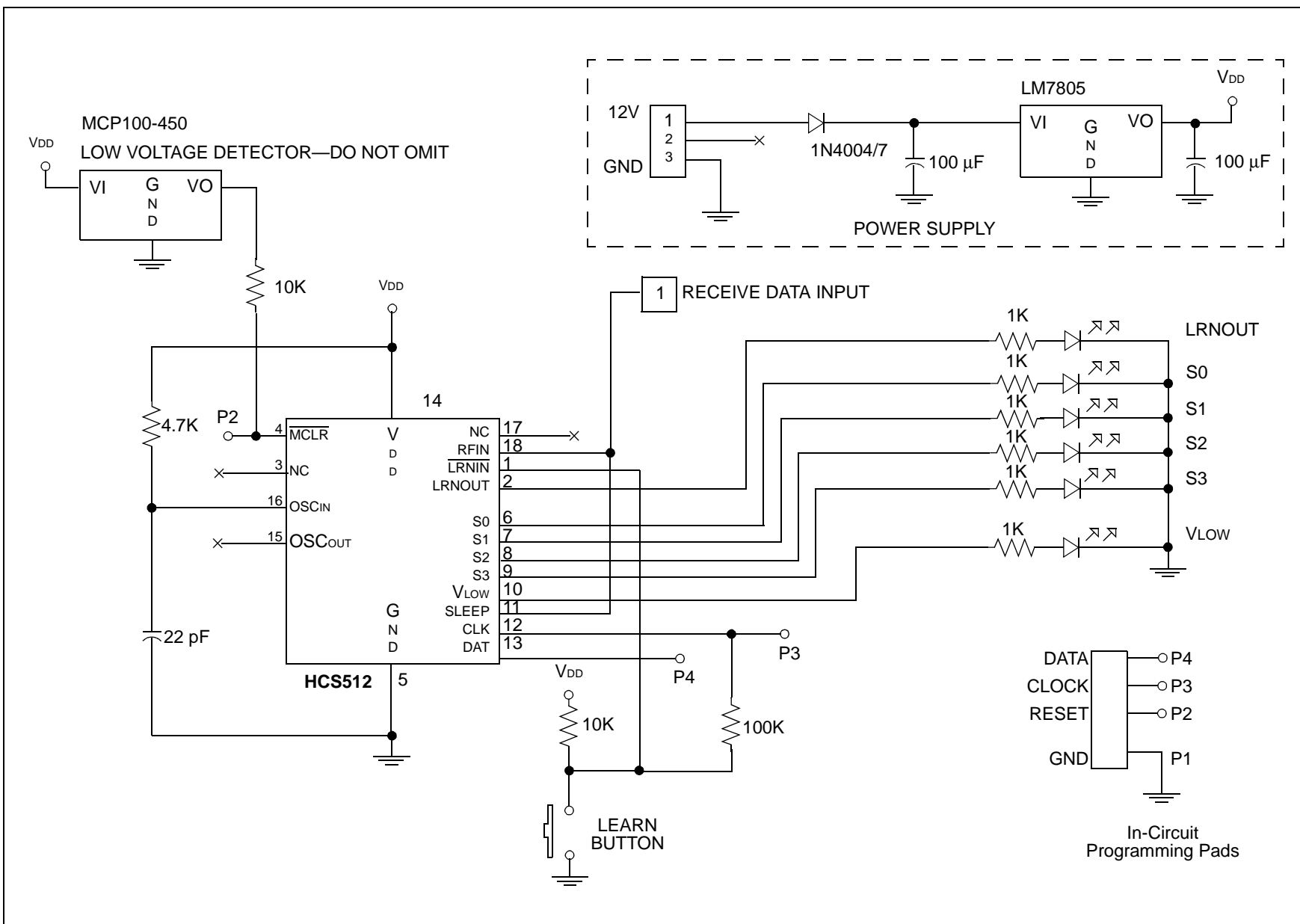

10.0 PACKAGING INFORMATION

10.1 Package Marking Information

18-Lead PDIP (300 mil)

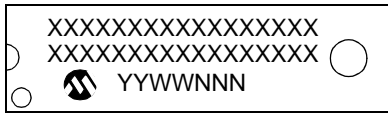

Example

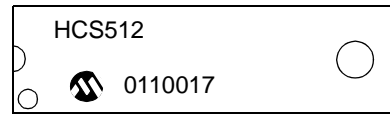

18-Lead SOIC (300 mil)

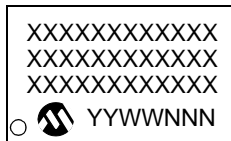

Example



Legend:	XX...X	Customer specific information*
	Y	Year code (last digit of calendar year)
	YY	Year code (last 2 digits of calendar year)
	WW	Week code (week of January 1 is week '01')
	NNN	Alphanumeric traceability code
Note: In the event the full Microchip part number cannot be marked on one line, it will be carried over to the next line thus limiting the number of available characters for customer specific information.		

* Standard PICmicro device marking consists of Microchip part number, year code, week code, and traceability code. For PICmicro device marking beyond this, certain price adders apply. Please check with your Microchip Sales Office. For QTP devices, any special marking adders are included in QTP price.

HCS512

10.2 Package Details

18-Lead Plastic Dual In-line (P) – 300 mil (PDIP)

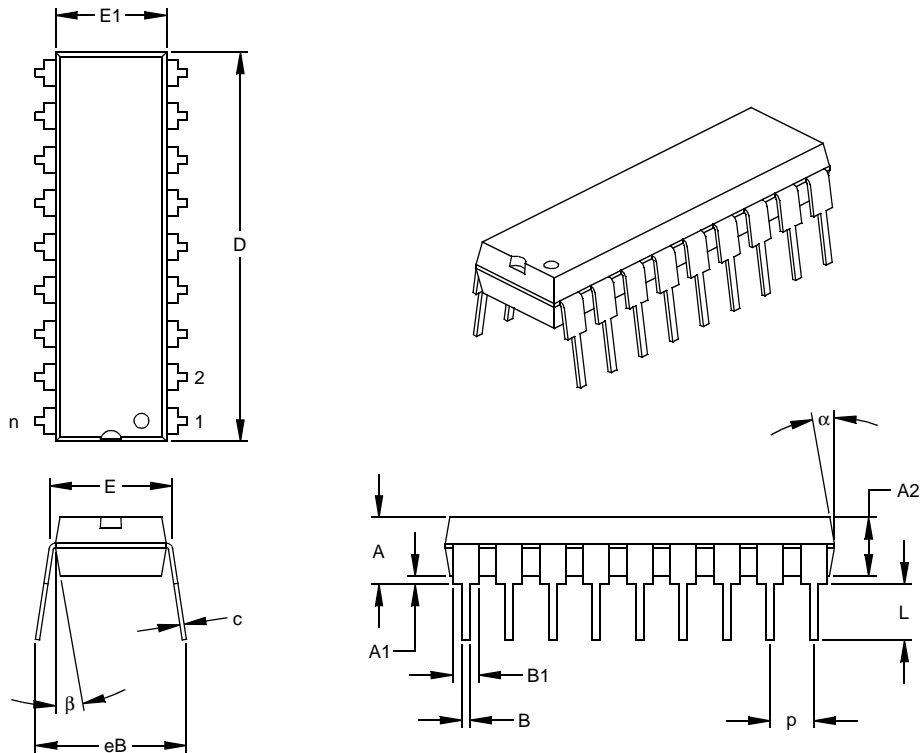

Dimension Limits	Units	INCHES*			MILLIMETERS		
		MIN	NOM	MAX	MIN	NOM	MAX
Number of Pins	n		18			18	
Pitch	P		.100			2.54	
Top to Seating Plane	A	.140	.155	.170	3.56	3.94	4.32
Molded Package Thickness	A2	.115	.130	.145	2.92	3.30	3.68
Base to Seating Plane	A1	.015			0.38		
Shoulder to Shoulder Width	E	.300	.313	.325	7.62	7.94	8.26
Molded Package Width	E1	.240	.250	.260	6.10	6.35	6.60
Overall Length	D	.890	.898	.905	22.61	22.80	22.99
Tip to Seating Plane	L	.125	.130	.135	3.18	3.30	3.43
Lead Thickness	c	.008	.012	.015	0.20	0.29	0.38
Upper Lead Width	B1	.045	.058	.070	1.14	1.46	1.78
Lower Lead Width	B	.014	.018	.022	0.36	0.46	0.56
Overall Row Spacing	§ eB	.310	.370	.430	7.87	9.40	10.92
Mold Draft Angle Top	α	5	10	15	5	10	15
Mold Draft Angle Bottom	β	5	10	15	5	10	15

* Controlling Parameter

§ Significant Characteristic

Notes:

Dimensions D and E1 do not include mold flash or protrusions. Mold flash or protrusions shall not exceed .010" (0.254mm) per side.

JEDEC Equivalent: MS-001

Drawing No. C04-007

18-Lead Plastic Small Outline (SO) – Wide, 300 mil (SOIC)

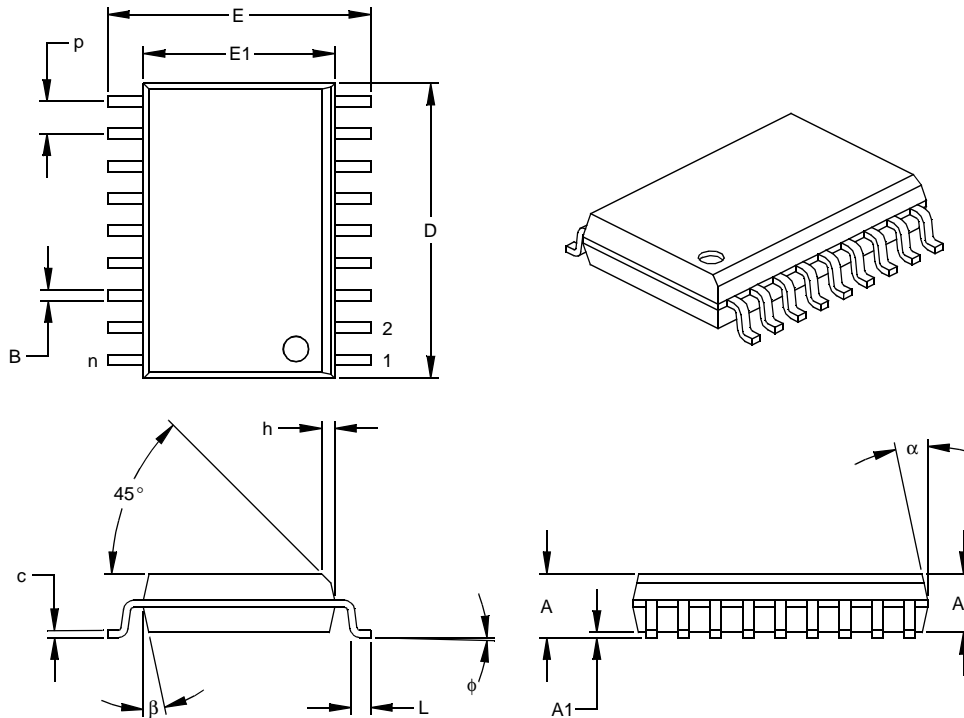

Dimension Limits	Units	INCHES*			MILLIMETERS		
		MIN	NOM	MAX	MIN	NOM	MAX
Number of Pins	n		18			18	
Pitch	p		.050			1.27	
Overall Height	A	.093	.099	.104	2.36	2.50	2.64
Molded Package Thickness	A2	.088	.091	.094	2.24	2.31	2.39
Standoff §	A1	.004	.008	.012	0.10	0.20	0.30
Overall Width	E	.394	.407	.420	10.01	10.34	10.67
Molded Package Width	E1	.291	.295	.299	7.39	7.49	7.59
Overall Length	D	.446	.454	.462	11.33	11.53	11.73
Chamfer Distance	h	.010	.020	.029	0.25	0.50	0.74
Foot Length	L	.016	.033	.050	0.41	0.84	1.27
Foot Angle	φ	0	4	8	0	4	8
Lead Thickness	c	.009	.011	.012	0.23	0.27	0.30
Lead Width	B	.014	.017	.020	0.36	0.42	0.51
Mold Draft Angle Top	α	0	12	15	0	12	15
Mold Draft Angle Bottom	β	0	12	15	0	12	15

* Controlling Parameter
 § Significant Characteristic

Notes:

Dimensions D and E1 do not include mold flash or protrusions. Mold flash or protrusions shall not exceed .010" (0.254mm) per side.

JEDEC Equivalent: MS-013

Drawing No. C04-051

ON-LINE SUPPORT

Microchip provides on-line support on the Microchip World Wide Web (WWW) site.

The web site is used by Microchip as a means to make files and information easily available to customers. To view the site, the user must have access to the Internet and a web browser, such as Netscape or Microsoft Explorer. Files are also available for FTP download from our FTP site.

Connecting to the Microchip Internet Web Site

The Microchip web site is available by using your favorite Internet browser to attach to:

www.microchip.com

The file transfer site is available by using an FTP service to connect to:

<ftp://ftp.microchip.com>

The web site and file transfer site provide a variety of services. Users may download files for the latest Development Tools, Data Sheets, Application Notes, User's Guides, Articles and Sample Programs. A variety of Microchip specific business information is also available, including listings of Microchip sales offices, distributors and factory representatives. Other data available for consideration is:

- Latest Microchip Press Releases
- Technical Support Section with Frequently Asked Questions
- Design Tips
- Device Errata
- Job Postings
- Microchip Consultant Program Member Listing
- Links to other useful web sites related to Microchip Products
- Conferences for products, Development Systems, technical information and more

Listing of seminars and events

Systems Information and Upgrade Hot Line

The Systems Information and Upgrade Line provides system users a listing of the latest versions of all of Microchip's development systems software products. Plus, this line provides information on how customers can receive any currently available upgrade kits. The Hot Line Numbers are:

1-800-755-2345 for U.S. and most of Canada, and

1-480-792-7302 for the rest of the world.

READER RESPONSE

It is our intention to provide you with the best documentation possible to ensure successful use of your Microchip product. If you wish to provide your comments on organization, clarity, subject matter, and ways in which our documentation can better serve you, please FAX your comments to the Technical Publications Manager at (480) 792-4150.

Please list the following information, and use this outline to provide us with your comments about this Data Sheet.

To: Technical Publications Manager Total Pages Sent
RE: Reader Response
From: Name _____
Company _____
Address _____
City / State / ZIP / Country _____
Telephone: (_____) _____ - _____ FAX: (_____) _____ - _____

Application (optional):

Would you like a reply? ___Y ___N

Device: **HCS512**

Literature Number: **DS40151D**

Questions:

1. What are the best features of this document?

2. How does this document meet your hardware and software development needs?

3. Do you find the organization of this data sheet easy to follow? If not, why?

4. What additions to the data sheet do you think would enhance the structure and subject?

5. What deletions from the data sheet could be made without affecting the overall usefulness?

6. Is there any incorrect or misleading information (what and where)?

7. How would you improve this document?

8. How would you improve our software, systems, and silicon products?

HCS512

HCS512 PRODUCT IDENTIFICATION SYSTEM

To order or obtain information, e.g., on pricing or delivery, refer to the factory or the listed sales office.

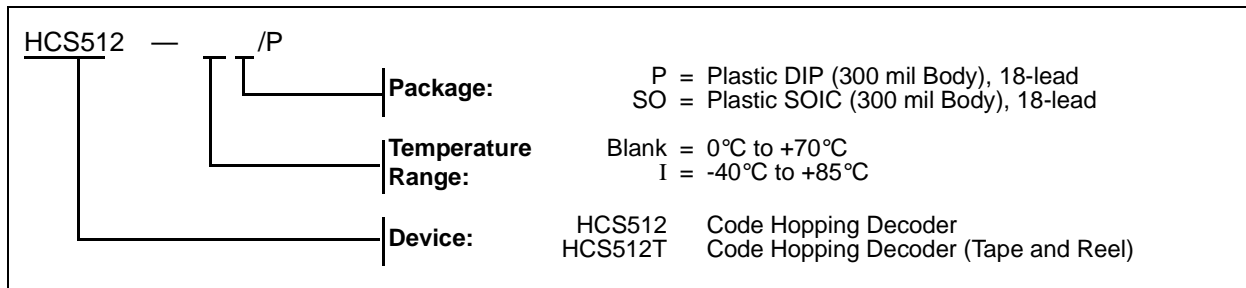

Sales and Support

Data Sheets

Products supported by a preliminary Data Sheet may have an errata sheet describing minor operational differences and recommended workarounds. To determine if an errata sheet exists for a particular device, please contact one of the following:

1. Your local Microchip sales office
2. The Microchip Corporate Literature Center U.S. FAX: (480) 792-7277
3. The Microchip Worldwide Site (www.microchip.com)

Please specify which device, revision of silicon and Data Sheet (include Literature #) you are using.

New Customer Notification System

Register on our web site (www.microchip.com/cn) to receive the most current information on our products.

Microchip's Secure Data Products are covered by some or all of the following patents:
Code hopping encoder patents issued in Europe, U.S.A., and R.S.A. — U.S.A.: 5,517,187; Europe: 0459781; R.S.A.: ZA93/4726
Secure learning patents issued in the U.S.A. and R.S.A. — U.S.A.: 5,686,904; R.S.A.: 95/5429

Information contained in this publication regarding device applications and the like is intended through suggestion only and may be superseded by updates. It is your responsibility to ensure that your application meets with your specifications. No representation or warranty is given and no liability is assumed by Microchip Technology Incorporated with respect to the accuracy or use of such information, or infringement of patents or other intellectual property rights arising from such use or otherwise. Use of Microchip's products as critical components in life support systems is not authorized except with express written approval by Microchip. No licenses are conveyed, implicitly or otherwise, under any intellectual property rights.

Trademarks

The Microchip name and logo, the Microchip logo, FilterLab, KEELOQ, MPLAB, PIC, PICmicro, PICMASTER, PICSTART, PRO MATE, SEEVAL and The Embedded Control Solutions Company are registered trademarks of Microchip Technology Incorporated in the U.S.A. and other countries.

dsPIC, ECONOMONITOR, FanSense, FlexROM, fuzzyLAB, In-Circuit Serial Programming, ICSP, ICEPIC, microID, microPort, Migratable Memory, MPASM, MPLIB, MPLINK, MPSIM, MXDEV, PICC, PICDEM, PICDEM.net, rPIC, Select Mode and Total Endurance are trademarks of Microchip Technology Incorporated in the U.S.A.

Serialized Quick Turn Programming (SQTP) is a service mark of Microchip Technology Incorporated in the U.S.A.

All other trademarks mentioned herein are property of their respective companies.

© 2002, Microchip Technology Incorporated, Printed in the U.S.A., All Rights Reserved.

 Printed on recycled paper.

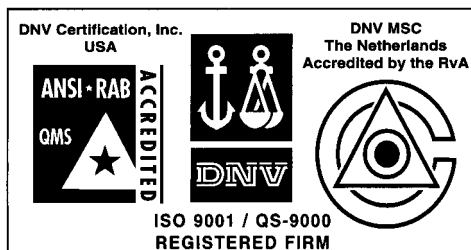

Microchip received QS-9000 quality system certification for its worldwide headquarters, design and wafer fabrication facilities in Chandler and Tempe, Arizona in July 1999. The Company's quality system processes and procedures are QS-9000 compliant for its PICmicro® 8-bit MCUs, KEELOQ® code hopping devices, Serial EEPROMs and microperipheral products. In addition, Microchip's quality system for the design and manufacture of development systems is ISO 9001 certified.



MICROCHIP

WORLDWIDE SALES AND SERVICE

AMERICAS

Corporate Office

2355 West Chandler Blvd.
Chandler, AZ 85224-6199
Tel: 480-792-7200 Fax: 480-792-7277
Technical Support: 480-792-7627
Web Address: <http://www.microchip.com>

Rocky Mountain

2355 West Chandler Blvd.
Chandler, AZ 85224-6199
Tel: 480-692-7966 Fax: 480-792-7456

Atlanta

500 Sugar Mill Road, Suite 200B
Atlanta, GA 30350
Tel: 770-640-0034 Fax: 770-640-0307

Boston

2 Lan Drive, Suite 120
Westford, MA 01886
Tel: 978-692-3848 Fax: 978-692-3821

Chicago

333 Pierce Road, Suite 180
Itasca, IL 60143
Tel: 630-285-0071 Fax: 630-285-0075

Dallas

4570 Westgrove Drive, Suite 160
Addison, TX 75001
Tel: 972-818-7423 Fax: 972-818-2924

Detroit

Tri-Atria Office Building
32255 Northwestern Highway, Suite 190
Farmington Hills, MI 48334
Tel: 248-538-2250 Fax: 248-538-2260

Kokomo

2767 S. Albright Road
Kokomo, Indiana 46902
Tel: 765-864-8360 Fax: 765-864-8387

Los Angeles

18201 Von Karman, Suite 1090
Irvine, CA 92612
Tel: 949-263-1888 Fax: 949-263-1338

New York

150 Motor Parkway, Suite 202
Hauppauge, NY 11788
Tel: 631-273-5305 Fax: 631-273-5335

San Jose

Microchip Technology Inc.
2107 North First Street, Suite 590
San Jose, CA 95131
Tel: 408-436-7950 Fax: 408-436-7955

Toronto

6285 Northam Drive, Suite 108
Mississauga, Ontario L4V 1X5, Canada
Tel: 905-673-0699 Fax: 905-673-6509

ASIA/PACIFIC

Australia

Microchip Technology Australia Pty Ltd
Suite 22, 41 Rawson Street
Epping 2121, NSW
Australia
Tel: 61-2-9868-6733 Fax: 61-2-9868-6755

China - Beijing

Microchip Technology Consulting (Shanghai)
Co., Ltd., Beijing Liaison Office
Unit 915
Bei Hai Wan Tai Bldg.
No. 6 Chaoyangmen Beidajie
Beijing, 100027, No. China
Tel: 86-10-85282100 Fax: 86-10-85282104

China - Chengdu

Microchip Technology Consulting (Shanghai)
Co., Ltd., Chengdu Liaison Office
Rm. 2401, 24th Floor,
Ming Xing Financial Tower
No. 88 TIDU Street
Chengdu 610016, China
Tel: 86-28-6766200 Fax: 86-28-6766599

China - Fuzhou

Microchip Technology Consulting (Shanghai)
Co., Ltd., Fuzhou Liaison Office
Unit 28F, World Trade Plaza
No. 71 Wusi Road
Fuzhou 350001, China
Tel: 86-591-7503506 Fax: 86-591-7503521

China - Shanghai

Microchip Technology Consulting (Shanghai)
Co., Ltd.
Room 701, Bldg. B
Far East International Plaza
No. 317 Xian Xia Road
Shanghai, 200051
Tel: 86-21-6275-5700 Fax: 86-21-6275-5060

China - Shenzhen

Microchip Technology Consulting (Shanghai)
Co., Ltd., Shenzhen Liaison Office
Rm. 1315, 13/F, Shenzhen Kerry Centre,
Renminnan Lu
Shenzhen 518001, China
Tel: 86-755-2350361 Fax: 86-755-2366086

Hong Kong

Microchip Technology Hongkong Ltd.
Unit 901-6, Tower 2, Metroplaza
223 Hing Fong Road
Kwai Fong, N.T., Hong Kong
Tel: 852-2401-1200 Fax: 852-2401-3431

India

Microchip Technology Inc.
India Liaison Office
Divyasree Chambers
1 Floor, Wing A (A3/A4)
No. 11, O'Shaugnessey Road
Bangalore, 560 025, India
Tel: 91-80-2290061 Fax: 91-80-2290062

Japan

Microchip Technology Japan K.K.
Benex S-1 6F
3-18-20, Shinyokohama
Kohoku-Ku, Yokohama-shi
Kanagawa, 222-0033, Japan
Tel: 81-45-471-6166 Fax: 81-45-471-6122

Korea

Microchip Technology Korea
168-1, Youngbo Bldg. 3 Floor
Samsung-Dong, Kangnam-Ku
Seoul, Korea 135-882
Tel: 82-2-554-7200 Fax: 82-2-558-5934

Singapore

Microchip Technology Singapore Pte Ltd.
200 Middle Road
#07-02 Prime Centre
Singapore, 188980
Tel: 65-334-8870 Fax: 65-334-8850

Taiwan

Microchip Technology Taiwan
11F-3, No. 207
Tung Hua North Road
Taipei, 105, Taiwan
Tel: 886-2-2717-7175 Fax: 886-2-2545-0139

EUROPE

Denmark

Microchip Technology Nordic ApS
Regus Business Centre
Lautrup høj 1-3
Ballerup DK-2750 Denmark
Tel: 45 4420 9895 Fax: 45 4420 9910

France

Microchip Technology SARL
Parc d'Activite du Moulin de Massy
43 Rue du Saule Trapu
Batiment A - 1er Etage
91300 Massy, France
Tel: 33-1-69-53-63-20 Fax: 33-1-69-30-90-79

Germany

Microchip Technology GmbH
Gustav-Heinemann Ring 125
D-81739 Munich, Germany
Tel: 49-89-627-144 0 Fax: 49-89-627-144-44

Italy

Microchip Technology SRL
Centro Direzionale Colleoni
Palazzo Taurus 1 V. Le Colleoni 1
20041 Agrate Brianza
Milan, Italy
Tel: 39-039-65791-1 Fax: 39-039-6899883

United Kingdom

Arizona Microchip Technology Ltd.
505 Eskdale Road
Winnersh Triangle
Wokingham
Berkshire, England RG41 5TU
Tel: 44 118 921 5869 Fax: 44-118 921-5820

01/18/02